

MODEL 1782 DIESEL

# CUBCADETPARTSNMORE.COM

## 515-266-7944

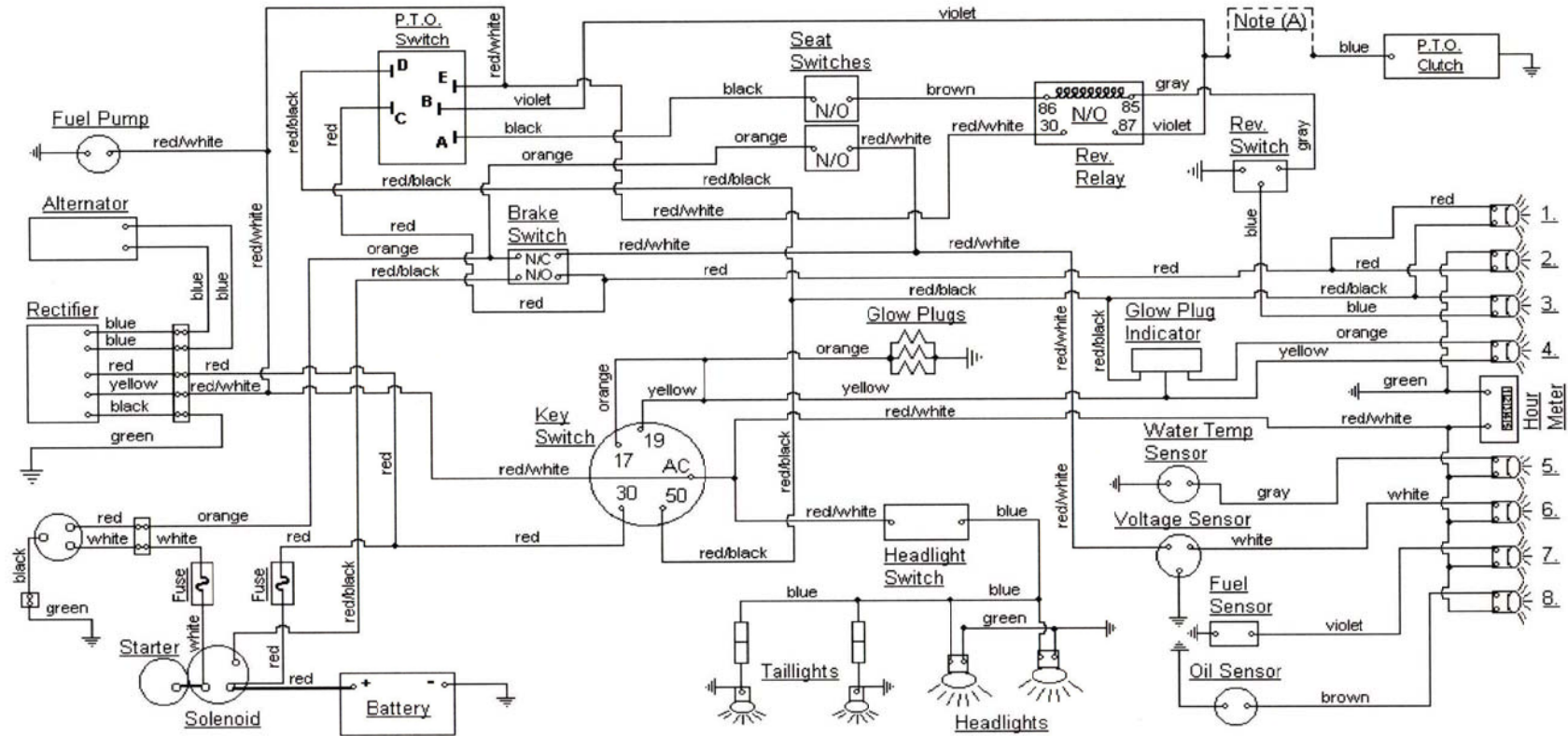

**NOTE: (A) REMOVE JUMPER FOR REAR P.T.O. INSTALLATION**

### PTO SWITCH

OFF	C+D
ON	B+A
START	B+A+E

### KEY SWITCH

PREHEAT	30+19+AC
ON	30+AC
START	30+50+17+AC

### DASH LIGHTS

1: DEPRESS LEFT PEDAL	5: WATER TEMP
2: DISENGAGE PTO	6: AMP
3: IN REVERSE	7: LOW FUEL
4: GLOW PLUGS	8: LOW OIL

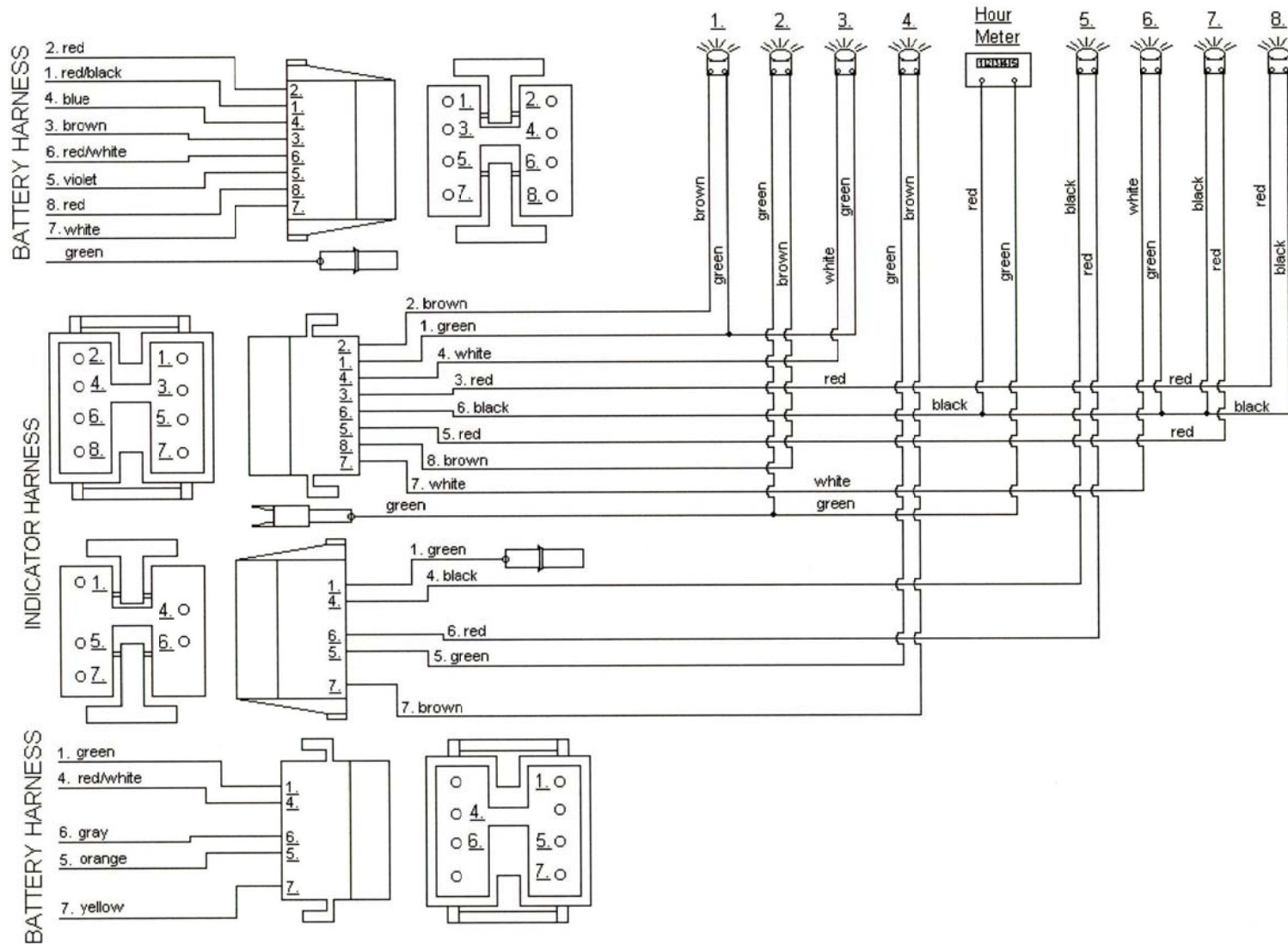

**DASH LIGHTS**

- |                       |               |
|-----------------------|---------------|
| 1: DEPRESS LEFT PEDAL | 5: WATER TEMP |
| 2: DISENGAGE PTO      | 6: AMP        |
| 3: IN REVERSE         | 7: LOW FUEL   |
| 4: GLOW PLUG          | 8: LOW OIL    |

**MODEL 1782 DIESEL  
INDICATOR HARNESS**