

NOTE: (A) REMOVE JUMPER FOR REAR P.T.O. INSTALLATION

PTO SWITCH	
OFF	C+D
ON	B+A
START	B+A+E

KEY SWITCH	
OFF	R+G
RUN w/LIGHTS	B+R+L
RUN	B+R
START	B+S

DASH LIGHTS	
1: DEPRESS LEFT PEDAL	5: AMP
2: DISENGAGE PTO	6: LOW FUEL
3: IN REVERSE	7: LOW OIL
4: WATER TEMP	

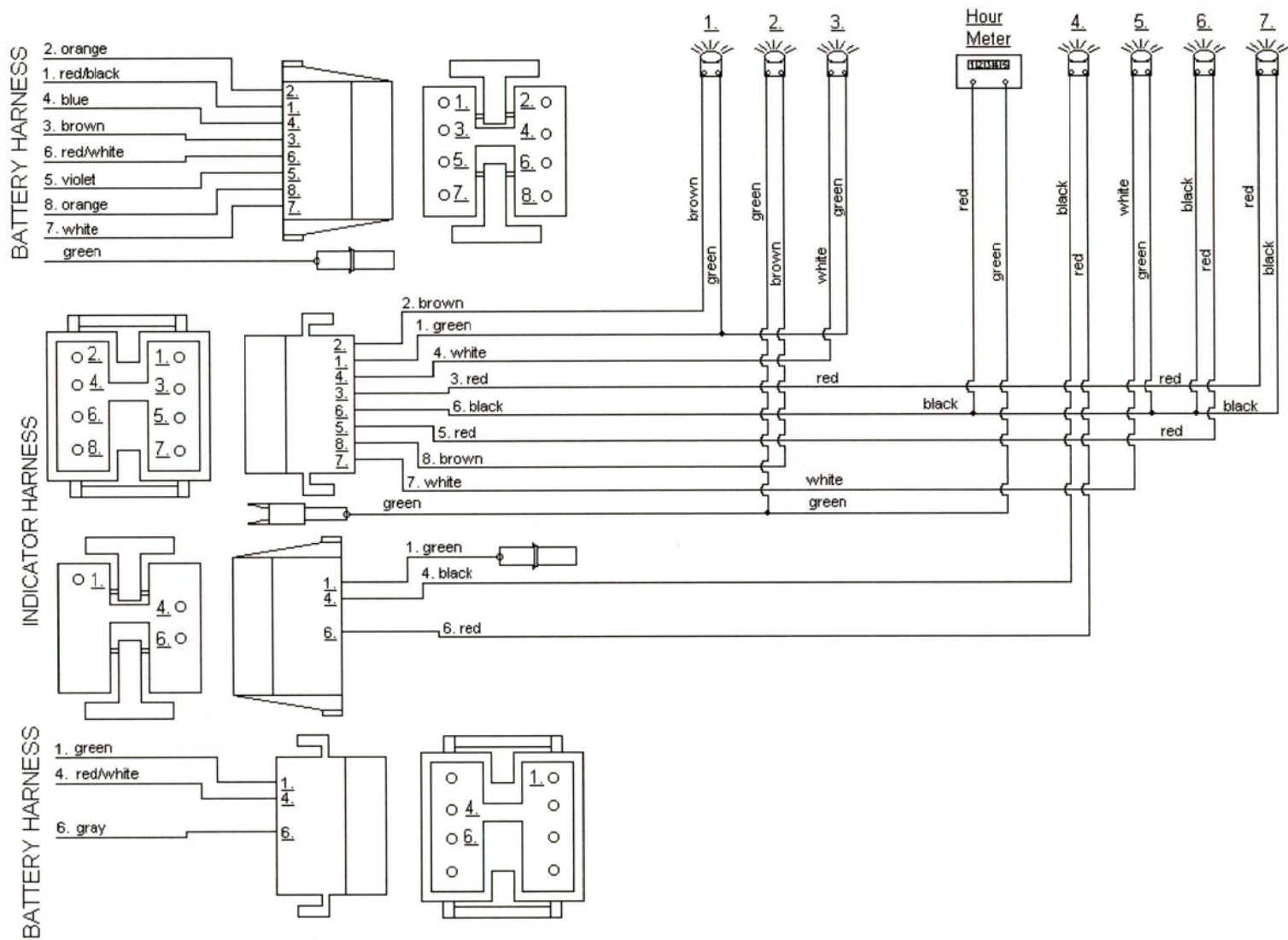

**MODEL 2182
INDICATOR HARNESS**

DASH LIGHTS	
1: DEPRESS LEFT PEDAL	5: AMP
2: DISENGAGE PTO	6: LOW FUEL
3: IN REVERSE	7: LOW OIL
4: WATER TEMP	