

Cub Cadet II.

OPERATOR'S MANUAL

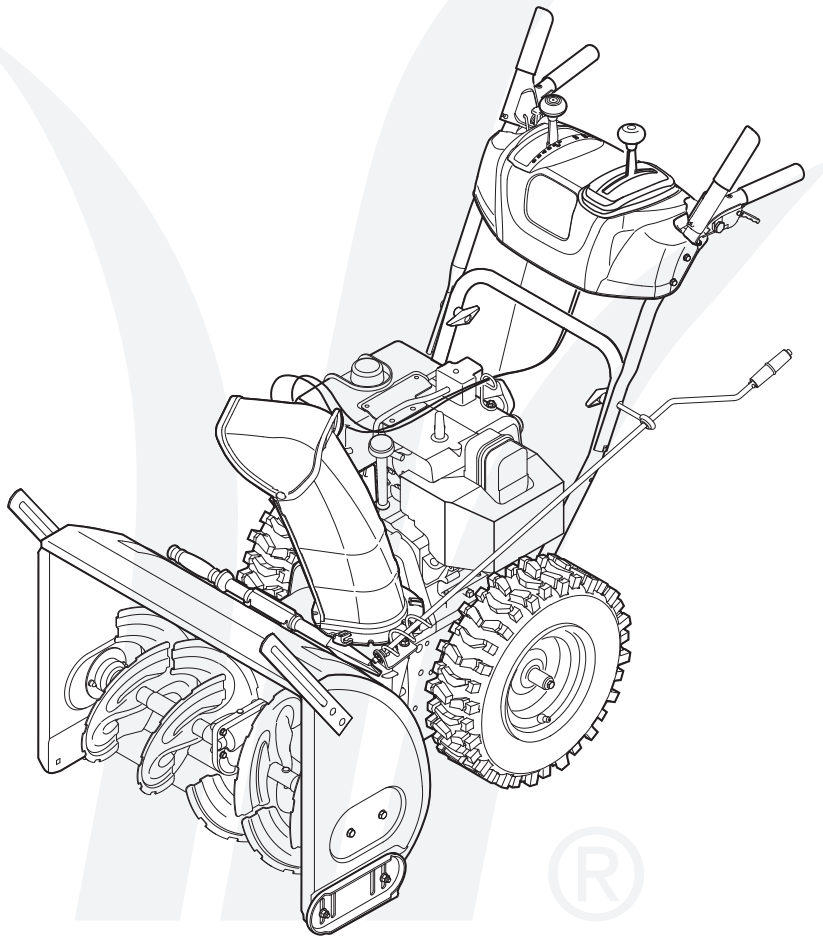

Two-Stage Snow Thrower — Model 528 SWE

IMPORTANT

READ SAFETY RULES AND INSTRUCTIONS CAREFULLY BEFORE OPERATION

Warning: This unit is equipped with an internal combustion engine and should not be used on or near any unimproved forest-covered, brush-covered or grass-covered land unless the engine's exhaust system is equipped with a spark arrester meeting applicable local or state laws (if any). If a spark arrester is used, it should be maintained in effective working order by the operator. In the State of California the above is required by law (Section 4442 of the California Public Resources Code). Other states may have similar laws. Federal laws apply on federal lands. A spark arrester for the muffler is available through your nearest engine authorized service dealer or contact the service department, P.O. Box 361131 Cleveland, Ohio 44136-0019.

CUB CADET LLC, P.O. BOX 361131 CLEVELAND, OHIO 44136-0019

This Operator's Manual is an important part of your new snow thrower. It will help you assemble, prepare and maintain the unit for best performance. Please read and understand what it says.

Table of Contents

Customer Support	2	Maintaining Your Snow Thrower	16
Safety Labels	3	Off-Season Storage	20
Safe Operation Practices	4	Troubleshooting.....	21
Setting Up Your Snow Thrower	6	Illustrated Parts List.....	22
Operating Your Snow Thrower	10	Warranty	31-32
Making Adjustments	14		

Finding and Recording Model Number

BEFORE YOU START ASSEMBLING YOUR NEW EQUIPMENT,

please locate the model plate on the equipment and copy the information to the sample model plate provided to the right. You can locate the model plate by standing at the operating position and looking down at the rear of the snow thrower. This information will be necessary to use the manufacturer's web site and/or obtain assistance from an authorized Cub Cadet dealer.

Cub Cadet
www.cubcadet.com
DEALER LOCATOR PHONE NUMBER: 877-282-8684

CUB CADET LLC
P. O. BOX 361131
CLEVELAND, OH 44136

Customer Support

If you have difficulty assembling this product or have any questions regarding the controls, operation, or maintenance of this unit, you can contact the dealer you purchased the unit from or choose from the options below:

1. Visit **cubcadet.com** for many useful suggestions. Click on Customer Service or the Service Locator to find the nearest Cub Cadet service dealer in your area.
2. To reach the Customer Dealer Referral Line, please call 1-877-282-8684.
3. The **engine manufacturer** is responsible for all engine-related issues with regards to performance, power-rating, specifications, warranty and service. Please refer to the engine manufacturer's Owner's/Operator's Manual, packed separately with your unit, for more information.

The screenshot shows the Cub Cadet website interface. At the top left is the Cub Cadet logo with the tagline "THE SCIENCE OF COMMON SENSE." To the right are links for "site map" and "customer service". Below the logo is a navigation bar with links: "HOME | ABOUT US | STORE LOCATOR | CUB CADET DIFFERENCE | FINANCING | YARD TIPS". Below the navigation bar are two tabs: "Answers" (which is selected and has a mouse cursor pointing to it) and "My Stuff". To the right of these tabs are "Login" and "Help" buttons. Below the tabs is a search area with a "Products & Services" dropdown menu set to "All Products", a "Search Text (optional)" input field, and a "Search" button. Below the search area is a "Search by" dropdown menu set to "Similar Phrases" and a "Powered by RightNow" logo.

⚠ DANGER

1. KEEP AWAY FROM ROTATING IMPELLER AND AUGER. CONTACT WITH IMPELLER OR AUGER CAN AMPUTATE HANDS AND FEET.
2. USE CLEAN-OUT TOOL TO UNCLOG DISCHARGE CHUTE.
3. DISENGAGE CLUTCH LEVERS, STOP ENGINE, AND REMAIN BEHIND HANDLES UNTIL ALL MOVING PARTS HAVE STOPPED BEFORE UNCLOGGING OR SERVICING MACHINE.
4. TO AVOID THROWN OBJECTS INJURIES, NEVER DIRECT DISCHARGE AT BYSTANDERS. USE EXTRA CAUTION WHEN OPERATING ON GRAVEL SURFACES.
5. READ OPERATOR'S MANUAL.

CLEAN-OUT TOOL



⚠ DANGER

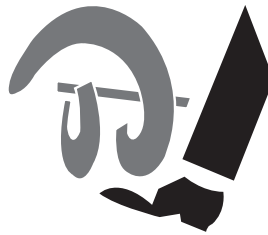

AVOID INJURY FROM ROTATING AUGER - KEEP HANDS, FEET AND CLOTHING AWAY.

⚠ DANGER

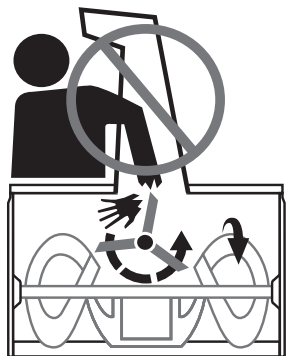

- NEVER PUT HAND IN CHUTE. CONTACT WITH ROTATING PARTS CAN AMPUTATE FINGERS AND HANDS.
- SHUT OFF ENGINE AND WAIT UNTIL ALL MOVING PARTS HAVE STOPPED BEFORE UNCLOGGING.
- USE CLEAN-OUT TOOL OR WOODEN STICK TO UNCLOG DISCHARGE CHUTE.

Chute Clean-out Tool

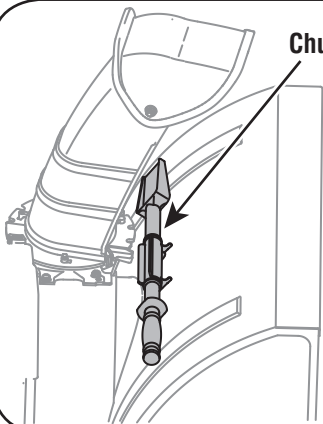

A chute clean-out tool is fastened to the top of the auger housing with a mounting clip. The tool is designed to clear a chute assembly of ice and snow.

This item is fastened with a cable tie at the factory. Cut the cable tie before operating the snow thrower.



WARNING: Never use your hands to clear a clogged chute assembly. Shut off engine and remain behind handles until all moving parts have stopped before using the clean-out tool to clear the chute assembly.

1

Safety Labels



WARNING

This symbol points out important safety instructions which, if not followed, could endanger the personal safety and/or property of yourself and others. Read and follow all instructions in this manual before attempting to operate this machine. Failure to comply with these instructions may result in personal injury. When you see this symbol.

HEED ITS WARNING!

Your Responsibility

Restrict the use of this power machine to persons who read, understand and follow the warnings and instructions in this manual and on the machine.

2

Safe Operation Practices



WARNING

This symbol points out important safety instructions which, if not followed, could endanger the personal safety and/or property of yourself and others. Read and follow all instructions in this manual before attempting to operate this machine. Failure to comply with these instructions may result in personal injury. When you see this symbol.

HEED ITS WARNING!

Your Responsibility

Restrict the use of this power machine to persons who read, understand and follow the warnings and instructions in this manual and on the machine.



WARNING: Engine Exhaust, some of its constituents, and certain vehicle components contain or emit chemicals known to State of California to cause cancer and birth defects or other reproductive harm.

DANGER: This machine was built to be operated according to the rules for safe operation in this manual. As with any type of power equipment, carelessness or error on the part of the operator can result in serious injury. This machine is capable of amputating hands and feet and throwing objects. Failure to observe the following safety instructions could result in serious injury or death.

Training

1. Read, understand, and follow all instructions on the machine and in the manual(s) before attempting to assemble and operate. Keep this manual in a safe place for future and regular reference and for ordering replacement parts.
2. Be familiar with all controls and their proper operation. Know how to stop the machine and disengage them quickly.
3. Never allow children under 14 years old to operate this machine. Children 14 years old and over should read and understand the operation instructions and safety rules in this manual and should be trained and supervised by a parent.
4. Never allow adults to operate this machine without proper instruction.
5. Thrown objects can cause serious personal injury. Plan your snow-throwing pattern to avoid discharge of material toward roads, bystanders and the like.
6. Keep bystanders, helpers, pets and children at least 75 feet from the machine while it is in operation. Stop machine if anyone enters the area.
7. Exercise caution to avoid slipping or falling, especially when operating in reverse.

Preparation

1. Thoroughly inspect the area where the equipment is to be used. Remove all doormats, newspapers, sleds, boards, wires and other foreign objects, which could be tripped over or thrown by the auger/impeller.
2. Always wear safety glasses or eye shields during operation and while performing an adjustment or repair to protect your eyes. Thrown objects which ricochet can cause serious injury to the eyes.
3. Do not operate without wearing adequate winter outer garments. Do not wear jewelry, long scarves or other loose clothing, which could become entangled in moving parts. Wear footwear which will improve footing on slippery surfaces.
4. Use a grounded three-wire extension cord and receptacle for all units with electric start engines.
5. Adjust collector housing height to clear gravel or crushed rock surfaces.
6. Disengage all control levers before starting the engine.
7. Never attempt to make any adjustments while engine is running, except where specifically recommended in the operator's manual.
8. Let engine and machine adjust to outdoor temperature before starting to clear snow.
9. To avoid personal injury or property damage use extreme care in handling gasoline. Gasoline is extremely flammable and the vapors are explosive. Serious personal injury can occur when gasoline is spilled on yourself or your clothes, which can ignite. Wash your skin and change clothes immediately.
 - a. Use only an approved gasoline container.
 - b. Extinguish all cigarettes, cigars, pipes and other sources of ignition.
 - c. Never fuel machine indoors.
 - d. Never remove gas cap or add fuel while the engine is hot or running.
 - e. Allow engine to cool at least two minutes before refueling.
 - f. Never over fill fuel tank. Fill tank to no more than ½ inch below bottom of filler neck to provide space for fuel expansion.
 - g. Replace gasoline cap and tighten securely.
 - h. If gasoline is spilled, wipe it off the engine and equipment. Move machine to another area. Wait 5 minutes before starting the engine.
 - i. Never store the machine or fuel container inside where there is an open flame, spark or pilot light (e.g. furnace, water heater, space heater, clothes dryer etc.).
 - j. Allow machine to cool at least 5 minutes before storing.

Operation

1. Do not put hands or feet near rotating parts, in the auger/impeller housing or chute assembly. Contact with the rotating parts can amputate hands and feet.
2. The auger/impeller control lever is a safety device. Never bypass its operation. Doing so makes the machine unsafe and may cause personal injury.
3. The control levers must operate easily in both directions and automatically return to the disengaged position when released.
4. Never operate with a missing or damaged chute assembly. Keep all safety devices in place and working.
5. Never run an engine indoors or in a poorly ventilated area. Engine exhaust contains carbon monoxide, an odorless and deadly gas.
6. Do not operate machine while under the influence of alcohol or drugs.
7. Muffler and engine become hot and can cause a burn. Do not touch.
8. Exercise extreme caution when operating on or crossing gravel surfaces. Stay alert for hidden hazards or traffic.
9. Exercise caution when changing direction and while operating on slopes.
10. Plan your snow-throwing pattern to avoid discharge towards windows, walls, cars etc. Thus, avoiding possible property damage or personal injury caused by a ricochet.
11. Never direct discharge at children, bystanders and pets or allow anyone in front of the machine.
12. Do not overload machine capacity by attempting to clear snow at too fast of a rate.
13. Never operate this machine without good visibility or light. Always be sure of your footing and keep a firm hold on the handles. Walk, never run.
14. Disengage power to the auger/impeller when transporting or not in use.
15. Never operate machine at high transport speeds on slippery surfaces. Look down and behind and use care when backing up.
16. If the machine should start to vibrate abnormally, stop the engine, disconnect the spark plug wire and ground it against the engine. Inspect thoroughly for damage. Repair any damage before starting and operating.
17. Disengage all control levers and stop engine before you leave the operating position (behind the handles). Wait until the auger/impeller comes to a complete stop before unclogging the chute assembly, making any adjustments, or inspections.
18. Never put your hand in the discharge or collector openings. Always use the clean-out tool provided to unclog the discharge opening. Do not unclog chute assembly while engine is running. Shut off engine and remain behind handles until all moving parts have stopped before unclogging.
19. Use only attachments and accessories approved by the manufacturer (e.g. wheel weights, tire chains, cabs etc.).
20. If situations occur which are not covered in this manual, use care and good judgment. Contact your dealer or call (877) 282-8684 for assistance and the name of your nearest servicing dealer..

Maintenance & Storage

1. Never tamper with safety devices. Check their proper operation regularly. Refer to the maintenance and adjustment sections of this manual.
2. Before cleaning, repairing, or inspecting machine disengage all control levers and stop the engine. Wait until the auger/impeller come to a complete stop. Disconnect the spark plug wire and ground against the engine to prevent unintended starting.
3. Check bolts and screws for proper tightness at frequent intervals to keep the machine in safe working condition. Also, visually inspect machine for any damage.
4. Do not change the engine governor setting or over-speed the engine. The governor controls the maximum safe operating speed of the engine.
5. Snow thrower shave plates and skid shoes are subject to wear and damage. For your safety protection, frequently check all components and replace with original equipment manufacturer's (OEM) parts only. "Use of parts which do not meet the original equipment specifications may lead to improper performance and compromise safety!"
6. Check controls periodically to verify they engage and disengage properly and adjust, if necessary. Refer to the adjustment section in this operator's manual for instructions.
7. Maintain or replace safety and instruction labels, as necessary.
8. Observe proper disposal laws and regulations for gas, oil, etc. to protect the environment.
9. Prior to storing, run machine a few minutes to clear snow from machine and prevent freeze up of auger/impeller.
10. Never store the machine or fuel container inside where there is an open flame, spark or pilot light such as a water heater, furnace, clothes dryer etc.
11. Always refer to the operator's manual for proper instructions on off-season storage. onment.

Do not modify engine

To avoid serious injury or death, do not modify engine in any way. Tampering with the governor setting can lead to a runaway engine and cause it to operate at unsafe speeds. Never tamper with factory setting of engine governor.

Notice regarding Emissions

Engines which are certified to comply with California and federal EPA emission regulations for SORE (Small Off Road Equipment) are certified to operate on regular unleaded gasoline, and may include the following emission control systems: Engine Modification (EM) and Three Way Catalyst (TWC) if so equipped.

Your Responsibility

Restrict the use of this power machine to persons who read, understand and follow the warnings and instructions in this manual and on the machine.

2

Safe Operation Practices



WARNING

This symbol points out important safety instructions, which if not followed, could endanger the personal safety and/or property of yourself and others. Read and follow all instructions in this manual before attempting to operate this machine. Failure to comply with these instructions may result in personal injury. When you see this symbol.

HEED IT'S WARNING!

Your Responsibility

Restrict the use of this power machine to persons who read, understand and follow the warnings and instructions in this manual and on the machine.

3

Setting Up Your Snow Thrower



NOTE: All references in this manual to the left or right side of the snow thrower is from the operating position only. Exceptions, if any, will be specified.

NOTE: If the flange keepers do not easily click into place, use the palm of your hand to apply swift, firm pressure to the back of each.

IMPORTANT

This unit is shipped with the engine full of oil. After assembly, refer to the Tecumseh Engines manual packed separately with your snow thrower for fuel and oil fill-up details.

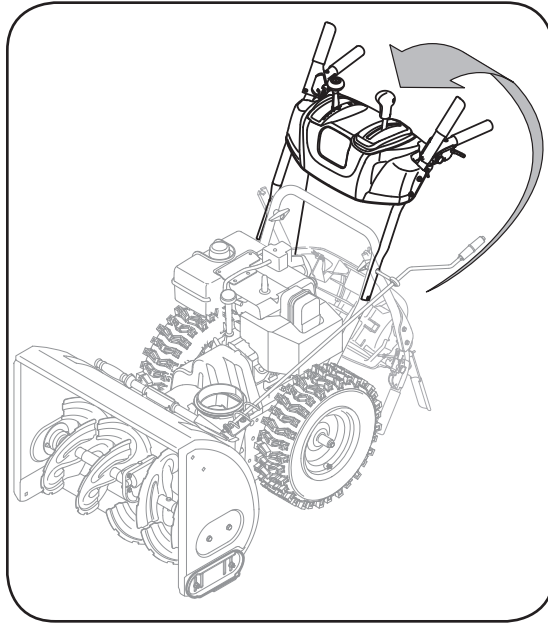

Figure 1

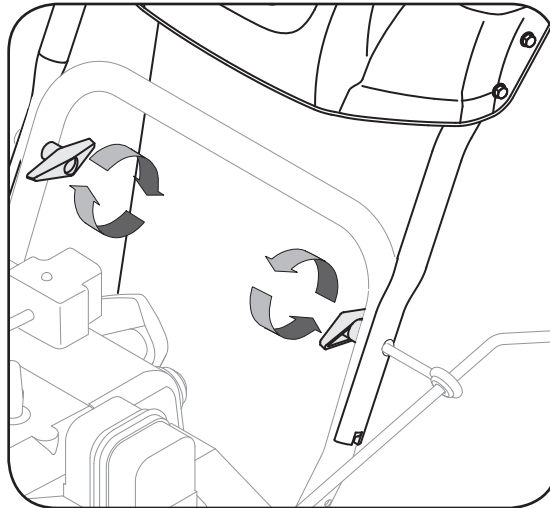

Figure 2

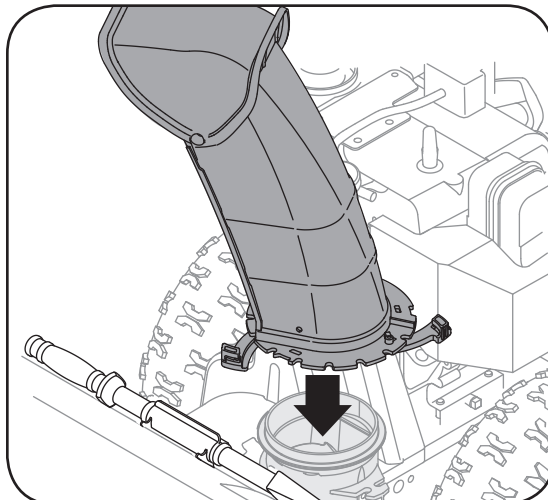

Figure 3

IMPORTANT: Two replacement auger shear pins are included with this manual (or stowed in the plastic handle panel). Refer to Augers on page 18 for more information regarding shear pin replacement.

1. Observe the lower area of the snow thrower to be sure both cables are aligned with roller guides before pivoting handle upward.
- Pull up and back on upper handle as shown in Figure 1. Align upper handle with the lower handle.
2. Secure the right side of the handle by tightening the plastic wing knob. Secure the left side of the handle by tightening the plastic wing knob into the eyebolt. See Figure 2.
3. Make sure that the flange keepers are opened. Position the chute assembly (forward-facing) over the chute base. See Figure 3.
4. Close the flange keepers to secure the chute assembly to the chute adapter. The keepers will click into place when properly secure. See Figure 4.

NOTE: If the flange keepers do not easily click into place, use the palm of your hand to apply swift, firm pressure to the back of each.

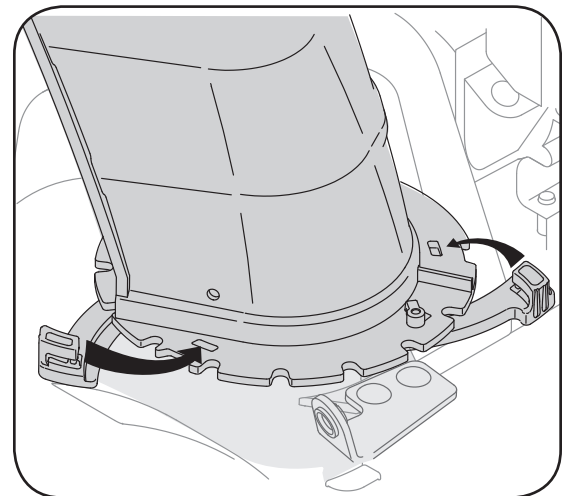

Figure 4

5. Remove the flat washer and hairpin clip from the end of the chute directional control.

- a. Insert the end of the chute directional control into the lower bracket.
- b. Secure with the flat washer and hairpin clip just removed. See Figure 5.

NOTE: If necessary, the lower bracket can be adjusted. Refer to Chute Bracket Adjustment. on Page 17.

6. Check that all cables are properly routed through the cable guide on top of the engine. See Figure 6.

The extension cord is fastened with a cable tie to the rear of the auger housing for shipping purposes. Cut the cable tie and remove it before operating the snow thrower.

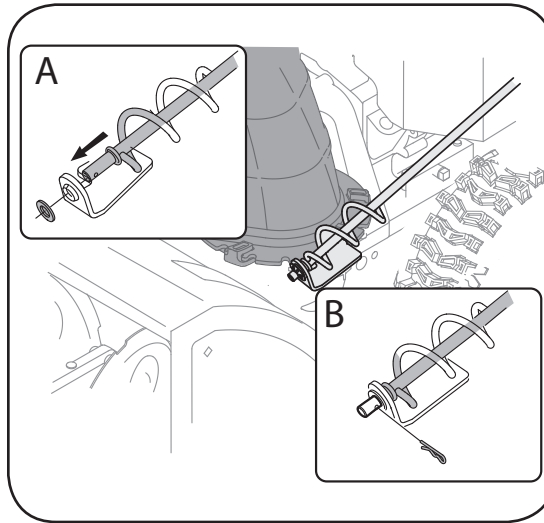

Figure 5



CAUTION: Prior to operating your snow thrower, refer to Auger Control Test on page 13. Read and follow all instructions carefully, and perform all adjustments to verify your snow thrower is operating safely and properly.

Shear Pin Storage

An area for convenient shear pin storage is located under the plastic dash panel. See Figure 7.

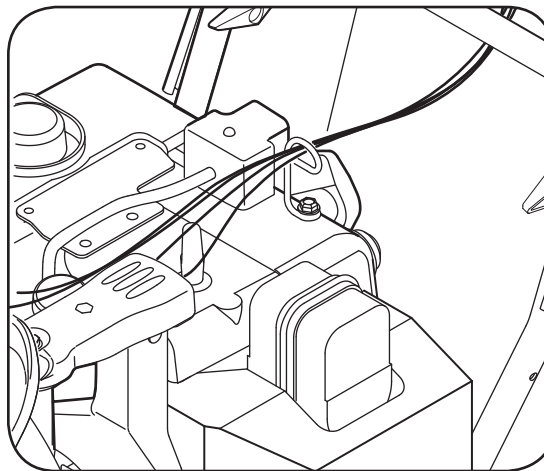

Figure 6

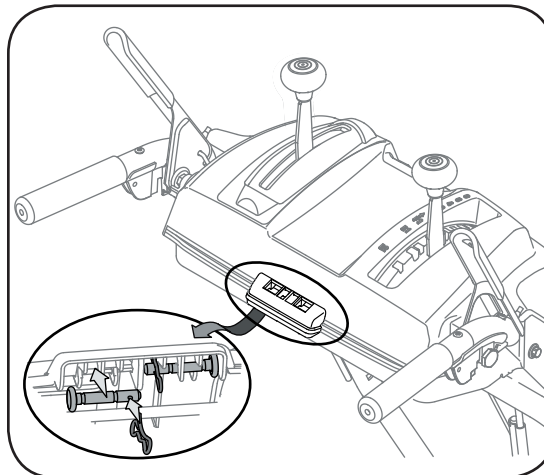

Figure 7

3

Setting Up Your Snow Thrower



CAUTION

Prior to operating your snow thrower, refer to Auger Control Test on page 13. Read and follow all instructions carefully and perform all adjustments to verify your unit is operating safely and properly.

3

Setting Up Your Snow Thrower

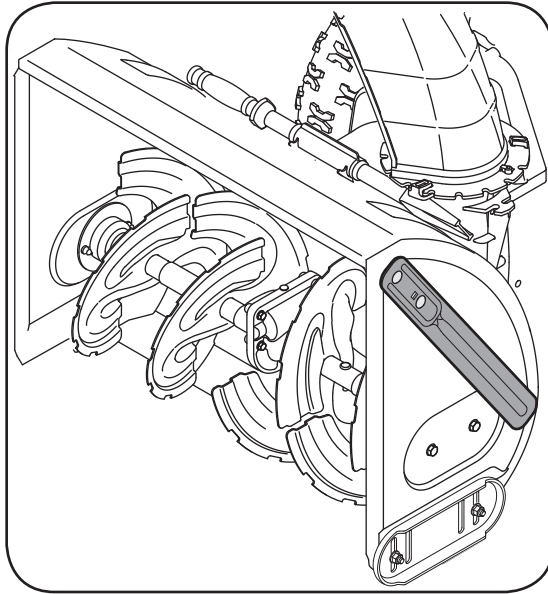

Figure 8

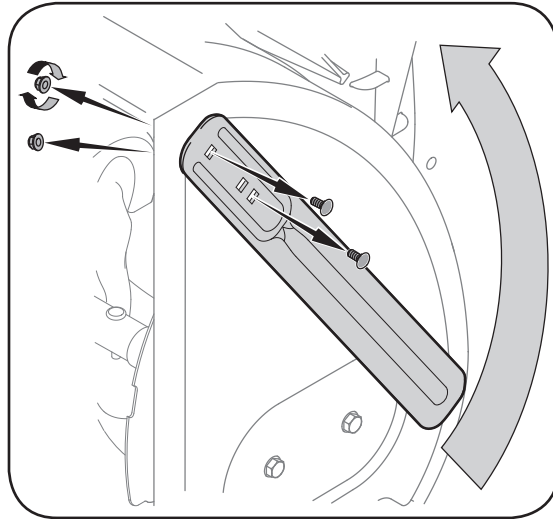

Figure 9

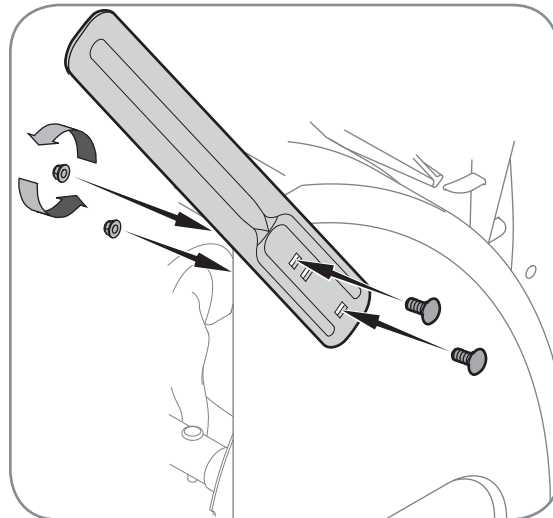

Figure 10

Drift Cutters

Drift cutters should be used when operating the snow thrower in heavy drift conditions.

- The drift cutters are assembled to the auger housing inverted. See Figure 8.
- Remove the carriage bolts by unthreading the hex nuts which secure them, and reinstall the drift cutters facing forward before operating the snow thrower. Refer to Figure 9.
- Secure to the auger housing with carriage bolts and hex nuts previously removed. See Figure 10.

Chute Clean-Out Tool

The clean-out tool is conveniently fastened to the rear of the auger housing with a mounting clip. See Figure 11.

1. Release both the auger control and the drive/auger control lock.
2. Stop the engine by moving the throttle to the stop position.
3. Remove the clean-out tool from the mounting clip.
4. Use the shovel-shaped end of the clean-out tool to remove any snow and ice in the chute assembly.
5. Re-fasten the clean-out tool to the mounting clip on the rear of the auger housing and restart engine.
6. While standing in the operator's position (behind the snow thrower), engage the auger control for a few seconds to clear any remaining snow or ice from the chute assembly before continuing to clear snow.

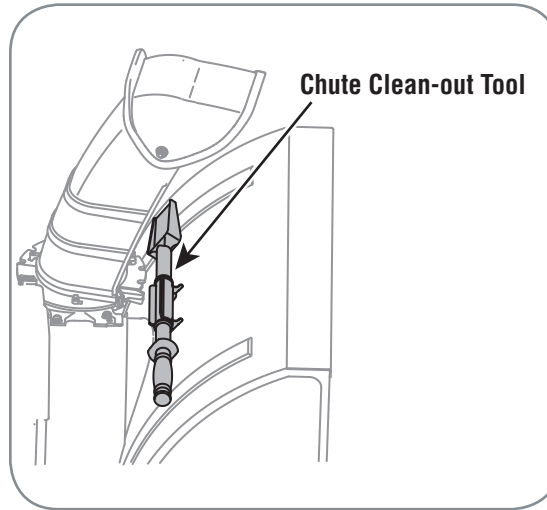

Figure 11



WARNING: Never use your hands to clean snow and ice from the chute assembly or auger housing.

Tire Pressure (Pneumatic Tires)

The tires are over-inflated for shipping purposes. Check the tire pressure before operating the snow thrower. Refer to the tire side wall for tire manufacturer's recommended psi and deflate (or inflate) the tires as necessary.

NOTE: If the tire pressure is not equal in both tires, the unit may not travel in a straight path and the shave plate may wear unevenly.

3

Setting Up Your Snow Thrower



WARNING

Never use your hands to clean snow and ice from the chute assembly or auger housing.



IMPORTANT

Under any circumstance do not exceed manufacturer's recommended psi. Equal tire pressure should be maintained at all times. Excessive pressure when seating beads may cause tire/rim assembly to burst with force sufficient to cause serious injury. Refer to sidewall of tire for recommended pressure.

4

Operating Your Snow Thrower



WARNING

Read, understand, and follow all instructions and warnings on the machine and in this manual before operating.

Use extreme care when handling gasoline. Gasoline is extremely flammable and the vapors are explosive. *Never* fuel the machine indoors or while the engine is hot or running. Extinguish cigarettes, cigars, pipes and other sources of ignition.

Know Your Snow Thrower

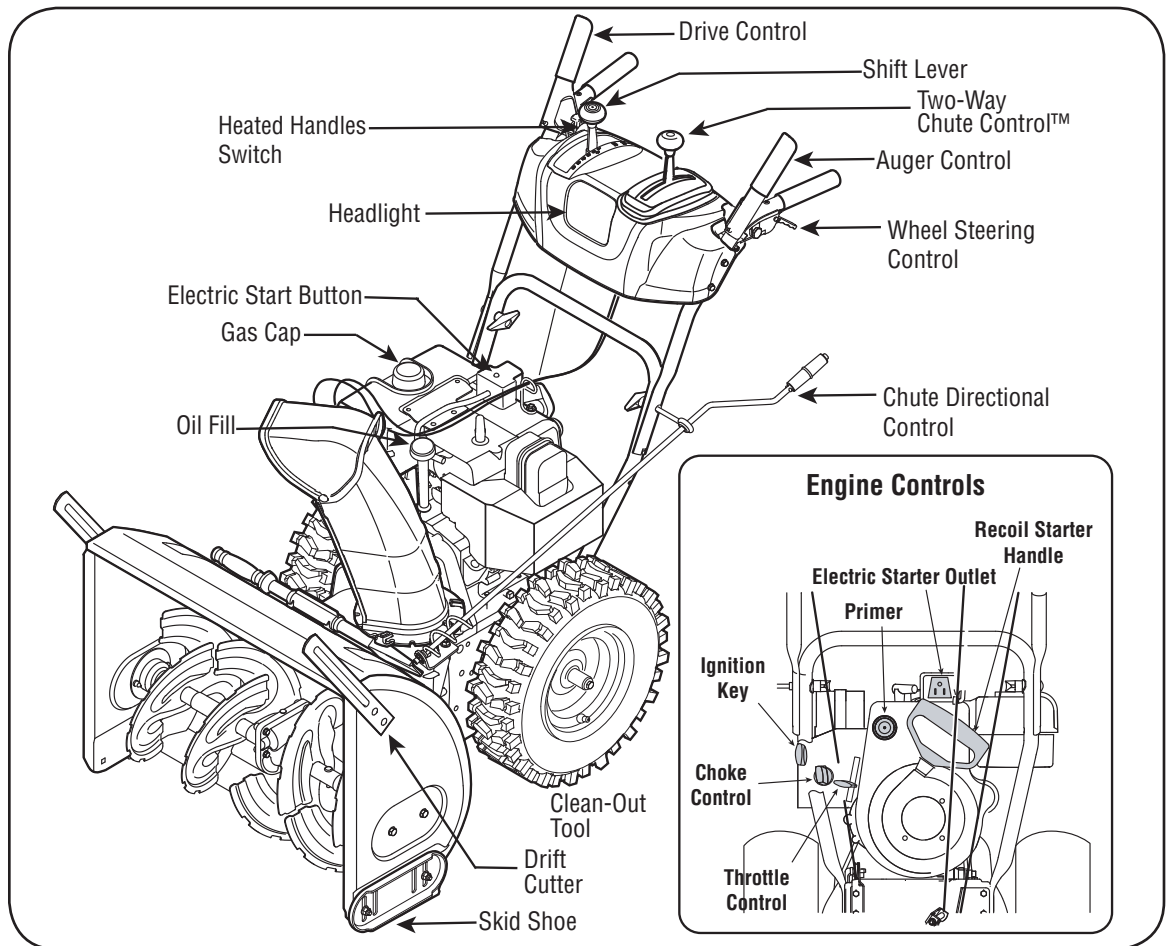

Figure 12

Now that you have set up your snow thrower for operation, get acquainted with its controls and features. These are described below and illustrated this page. This knowledge will allow you to use your new equipment to its fullest potential.

NOTE: For detailed starting instructions and more information on all engine controls, refer to the *Tecumseh Engines* manual packed separately and **Starting The Engine** on page 12 of this manual.

Shift Lever

The shift lever is located on the right side of the handle panel. Place the shift lever into any of eight positions to control the direction of travel and ground speed.

Forward

Your snow thrower has six forward (F) speeds, with position number one (1) being the slowest speed.

Reverse

Your snow thrower has two reverse (R) speeds, with position number one (1) being the slower speed.

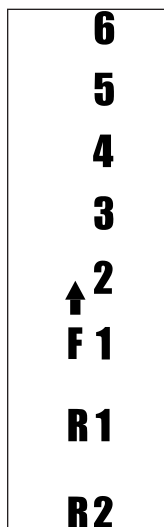

Choke Control



The choke control is found on the rear of the engine and is activated by rotating the knob clockwise. Activating the choke control closes the choke plate on the carburetor and aids in starting the engine.

Throttle Control

The throttle control is located on the engine. It regulates the speed of the engine and will shut off the engine when pushed down completely.

Primer

Depressing the primer forces fuel directly into the engine's carburetor to aid in cold-weather starting.

Oil Fill

Engine oil level can be checked and oil added through the oil fill.

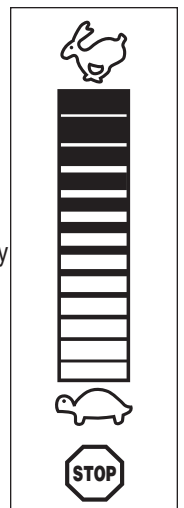

Auger Control

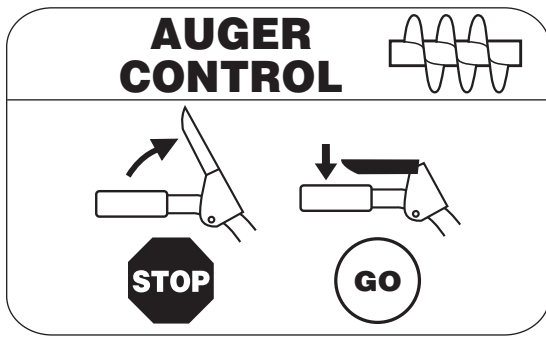

The auger control is located on the left handle. Squeeze the control grip against the handle to engage the augers and start snow throwing action. Release to stop.

Drive Control/ Auger Control Lock

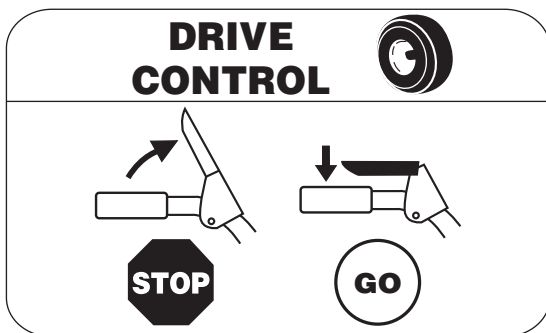

The drive control is located on the right handle. Squeeze the control grip against the handle to engage the wheel drive. Release to stop.

The drive control also locks the auger control so you can operate the chute directional control without interrupting the snow throwing process. If the auger control is engaged simultaneously with the drive control, the operator can release the auger control (on the left handle) and the augers will remain engaged. Release both controls to stop the augers and wheel drive.

IMPORTANT: Always release the drive control before changing speeds.

Two-Way Chute Control™

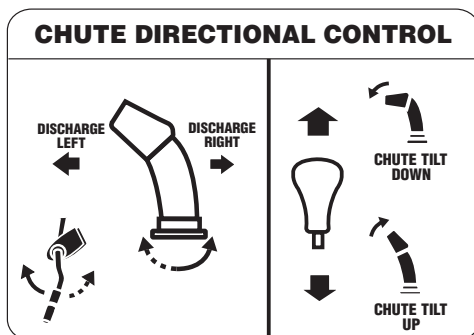

The two-way chute control is located on the left side of the dash panel and is meant to control the distance of snow discharge from the chute.

- To change the **angle/distance** which snow is thrown, pivot the joy-stick forward or backward.

Chute Directional Control

The chute directional control is located on the left side of the snow thrower.

- To change the **direction** in which snow is thrown, crank clockwise to discharge to the left and counter-clockwise to discharge to the right.

Wheel Steering Controls

The left and right wheel steering controls are located on the underside of the handles. Squeeze the right control to turn right; squeeze the left control to turn left.

NOTE: Operate the snow thrower in open areas until you are familiar with these controls.

Ignition Key

The ignition key must be inserted and snapped in place in order for the engine to start. Remove the ignition key to prevent unauthorized use of equipment. Do NOT attempt to turn the key.

Clean-Out Tool



WARNING: Never use your hands to clear a clogged chute assembly. Shut off engine and remain behind handles until all moving parts have stopped before unclogging.

The clean-out tool is mounted to the rear of the auger housing and is designed to clear a clogged chute. Refer to page 9 for instructions on how to properly use it.

NOTE: This item is fastened with a cable tie to the rear of the auger housing at the factory. Cut the cable tie before operating the snow thrower.

Skid Shoes

Position the skid shoes based on surface conditions. Adjust upward for hard-packed snow. Adjust downward when operating on gravel or crushed rock surfaces.

Drift Cutters

Drift cutters should be used when operating the snow thrower in heavy drift conditions.

Heated Handles Switch

This switch is located on the right side of the snow thrower dash panel. To activate the heated handles, toggle the switch to the right to generate heat within the handle grips. Toggle the switch to the left to the OFF position after using the snow thrower. See Figure 12.

NOTE: The heated handles grips are a compliment to, not a substitute for, proper cold weather outerwear for the operator's hands. It is recommended that the snow thrower operator wear gloves/mittens to avoid extremities of winter while operating this equipment.

4

Operating Your Snow Thrower



WARNING

The operation of any snow thrower can result in foreign objects being thrown into the eyes, which can damage your eyes severely. Always wear safety glasses while operating the snow thrower, or while performing any adjustments or repairs on it.

Be sure no one other than the operator is standing near the snow thrower while starting engine or operating snow thrower. Never run engine indoors or in enclosed, poorly ventilated areas. Engine exhaust contains carbon monoxide, an odorless and deadly gas. Keep hands, feet, hair and loose clothing away from any moving parts on engine and snow thrower.



WARNING

Read, understand, and follow all instructions and warnings on the machine and in this manual before operating.

Use extreme care when handling gasoline. Gasoline is extremely flammable and the vapors are explosive. Never fuel the machine indoors or while the engine is hot or running. Extinguish cigarettes, cigars, pipes and other sources of ignition.

If your home's wiring system is not a three-wire grounded system, do not use this electric starter under any conditions.

If your home electrical system is grounded, but a three-hole receptacle is not available, do not use your snow thrower's electric starter.

Gas & Oil Fill-Up

Service the engine with gasoline and oil as instructed in the Tecumseh Engines manual packed separately with your snow thrower. Read instructions carefully.

Starting The Engine

1. Attach spark plug wire to spark plug. Make certain the metal loop on the end of the spark plug wire (inside the rubber boot) is fastened securely over the metal tip on the spark plug.
2. Make certain both the auger control and drive control are in the disengaged (released) position.
3. Move throttle control up to FAST position. Insert ignition key into slot. Make sure it snaps into place. Do not attempt to turn the key.

NOTE: The engine cannot start unless the key is inserted into ignition switch.

Electric Starter

1. Determine that your home's wiring is a three-wire grounded system. Ask a licensed electrician if you are not certain.



WARNING: The optional electric starter is equipped with a grounded three-wire power cord and plug, and is designed to operate on 120 volt AC household current. It must be used with a properly grounded three-prong receptacle at all times to avoid the possibility of electric shock. Follow all instructions carefully prior to operating the electric starter.

If you have a grounded three-prong receptacle, proceed as follows:

1. Plug the extension cord into the outlet located on the engine's surface. Plug the other end of extension cord into a three-prong 120-volt, grounded, AC outlet in a well-ventilated area.
2. Rotate choke control to FULL choke position (for a cold engine start).

NOTE: If the engine is already warm, place choke control in the OFF position instead of FULL.

3. Push the primer two or three times for cold engine start, making sure to cover vent hole in the center of the primer when pushing.

NOTE: DO NOT use primer to restart a warm engine after a short shutdown.

4. Push starter button to start engine.
5. Once the engine starts, immediately release starter button.

6. As the engine warms, slowly rotate the choke control to the OFF position. If the engine falters, quickly rotate the choke control back to FULL and then slowly into the OFF position again.
7. When disconnecting the extension cord, always unplug the end at the three-prong wall outlet before unplugging the opposite end from the snow thrower.

Recoil Starter

1. Rotate choke control to FULL choke position (cold engine start).

NOTE: If the engine is already warm, place choke control in the OFF position instead of FULL.

2. Push the primer two or three times for cold engine start, making sure to cover vent hole in the center of the primer when pushing.

NOTE: DO NOT use primer to restart a warm engine after a short shutdown.

NOTE: Additional priming may be necessary if the temperature is below 15° Fahrenheit.

3. Grasp the recoil starter handle and slowly pull the rope out. At the point where it becomes slightly harder to pull the rope, slowly allow the rope to recoil.
4. Pull the starter handle with a firm, rapid stroke. Do not release the handle and allow it to snap back. Keep a firm hold on the starter handle and allow it to slowly recoil.
5. As the engine warms, slowly rotate the choke control to the OFF position. If the engine falters, quickly rotate the choke control back to the FULL position and then slowly into the OFF position again.

NOTE: Allow the engine to warm up for a few minutes after starting. The engine will not develop full power until it reaches operating temperatures.

Stopping The Engine

Run engine for a few minutes before stopping to help dry off any moisture on the engine.

- To help prevent possible starter freeze-up, proceed as follows:

Electric Starter

1. Connect extension cord to the electric starter outlet on the engine, then to 120 volt AC outlet.
2. With the engine running, push the starter button and allow the starter for spin for several seconds. The noise made by the starter is normal. The engine's starter is not being harmed.

- When disconnecting the extension cord, always unplug the end at the three-prong wall outlet before unplugging the opposite end from the snow thrower.
- Move throttle control to STOP position.
- Remove the ignition key (Do not turn key) to prevent unauthorized use of equipment.
- Wipe all snow and moisture from the area around the engine as well as the area in and around the drive control and auger control. Also, engage and release both controls several times.

NOTE: Keep the key in a safe place. The engine cannot start without the ignition key.

Recoil Starter

- With engine running, pull starter rope with a rapid, continuous full arm stroke three or four times. Pulling the starter rope will produce a loud clattering sound, which is not harmful to engine.
- Move throttle control to STOP position.
- Remove the ignition key (Do not turn key) to prevent unauthorized use of equipment.

NOTE: Keep the key in a safe place. The engine cannot start without the ignition key.

- Wipe all snow and moisture from the area around the engine as well as the area in and around the drive control and auger control. Also, engage and release both controls several times.

To Engage Drive

- With the engine running near top speed, move shift lever to one of six FORWARD positions or two REVERSE positions. Select a speed appropriate for the snow conditions that exist.
- Squeeze drive control against the right handle and the snow thrower will move. Release it and the drive motion will stop.
- To turn the unit left or right, squeeze the respective wheel steering control. See Figure 12.

To Engage Augers

- To engage augers and start snow throwing, squeeze the left hand auger control against the left handle. Release to stop augers.
- While the auger control is engaged, squeeze the drive control to move, release to stop. Do not shift speeds while the drive is engaged.

NOTE: This same lever also locks auger control so you can turn the chute control without interrupting the snow throwing process.

- Release the auger control; the interlock mechanism should keep the auger control engaged until the drive control is released.
- Release the drive control to stop both the augers and the wheel drive. To stop the auger, both levers must be released.

Auger Control Test

Perform the following test before operating your snow thrower for the first time and at the start of each winter. Check the adjustment of the auger control as follows:

- When the auger control is released and in the disengaged “up” position, the cable should have very little slack. It should NOT be tight.
- In a well-ventilated area, start the snow thrower engine as instructed on the previous page. Make sure the throttle is set in the FAST position.
- While standing in the operator’s position (behind the snow thrower), engage the auger.
- Allow the auger to remain engaged for approximately ten (10) seconds before releasing the auger control. Repeat this several times.
- With the throttle control in the FAST (rabbit) position and the auger control in the disengaged “up” position, walk to the front of the machine.
- Confirm that the auger has completely stopped rotating and shows NO signs of motion. If the auger shows ANY signs of rotating, immediately return to the operator’s position and shut off the engine. Wait for ALL moving parts to stop before re-adjusting the auger control.
- To readjust the control cable, loosen the upper hex nut on the auger cable bracket.
- Position the bracket upward to provide more slack (or downward to increase cable tension). See Figure 13.
- Retighten the upper hex nut.
- Repeat Auger Control Test to verify proper adjustment has been achieved.

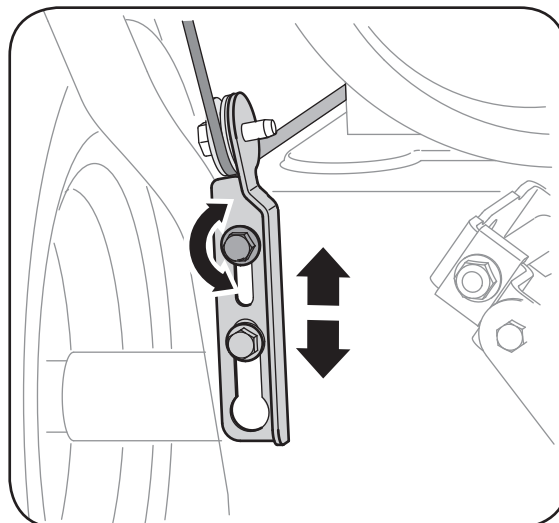

Figure 13



WARNING

The muffler, engine and surrounding areas become hot and can cause a burn. Do not touch.



When selecting a Drive Speed, use the slower speeds until you are comfortable and familiar with the operation of the snow thrower.

NEVER reposition the shift lever (change speeds or direction of travel) without first releasing the drive control and bringing the snow thrower to a complete stop. Doing so will result in premature wear to the snow thrower’s drive system.

5

Making Adjustments



WARNING

Read, understand, and follow all instructions and warnings on the machine and in this manual before operating.

Never attempt to make any adjustments while the engine is running, except where specified in operator's manual.

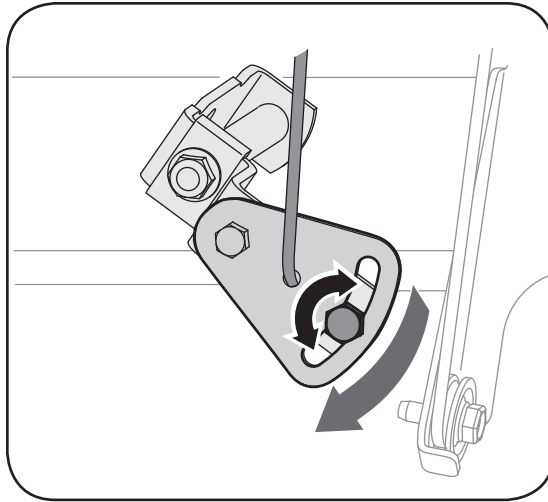

Figure 14

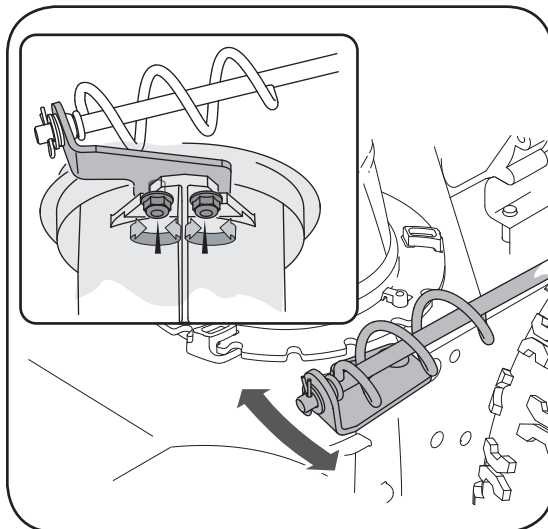

Figure 15

Shift Cable

If the full range of speeds (forward and reverse) cannot be achieved, refer to the figure to the left and adjust the shift cable as follows:

1. Place the shift lever in the **fastest** forward speed position.
2. Loosen the hex nut on the shift cable index bracket. See Figure 14.
3. Pivot the bracket downward to take up slack in the cable.
4. Retighten the hex nut.
5. Check for correct adjustment before operating the snow thrower.

Chute Bracket Adjustment

If the spiral at the bottom of the chute directional control is not fully engaging with the chute assembly, the chute bracket can be adjusted. To do so, loosen the two nuts which secure the chute bracket and reposition it slightly before retightening the nuts. See Figure 15.

Drive Control & Shift Lever

When the drive control is released and in the disengaged "up" position, the cable should have very little slack. It should NOT be tight.

Check the adjustment of the drive control as follows:

1. With the drive control released, push the snow thrower gently forward. The unit should roll freely.
2. Engage the drive control and gently attempt to push the snow thrower forward. The wheels should not turn. The unit should not roll freely.
3. With the drive control released, move the shift lever back and forth between the R2 position and the F6 position several times. There should be no resistance in the shift lever.

4. If any of the above tests failed, the drive cable is in need of adjustment. Proceed as follows:
5. Loosen the lower hex nut on the drive cable bracket. See Figure 16.
6. Position the bracket upward to provide more slack (or downward to increase cable tension).
7. Retighten the lower hex nut.

You can also check the adjustment as follows:

1. With the snow thrower tipped forward (be certain to drain gasoline or place plastic film under the gas cap if the snow thrower has already been operated), remove the frame cover underneath the snow thrower by removing the self-tapping screws. Refer to Figure 22 on page 17.
2. With the drive control released, there must be 1/8" clearance between the friction wheel and the drive pulley in all positions of the shift lever.
3. With the drive control engaged, the friction wheel must contact the drive pulley. Refer to Figure 24 on page 18.
4. If adjustment is necessary, loosen the lower hex nut on the drive cable index bracket and pivot the bracket upward or downward as necessary. Refer to Figure 16. Tighten the lower hex nut to secure the bracket when correct adjustment is reached.
5. Reassemble the frame cover and turn the unit back to its operating position.

NOTE: If you placed plastic under the gas cap, be certain to remove it now.

Auger Control

To adjust the auger control, refer to page 13.

Skid Shoes

The space between this shave plate and the ground can be adjusted. For close snow removal, place skid shoes in the low position. Use middle or high position when area to be cleared is uneven.

1. Adjust skid shoes by loosening the four lock nuts and carriage bolts and moving skid shoes to desired position. See Figure 17.
2. Make certain the entire bottom surface of skid shoes are against the ground to avoid uneven wear on the skid shoes.
3. Tighten nuts and bolts securely.

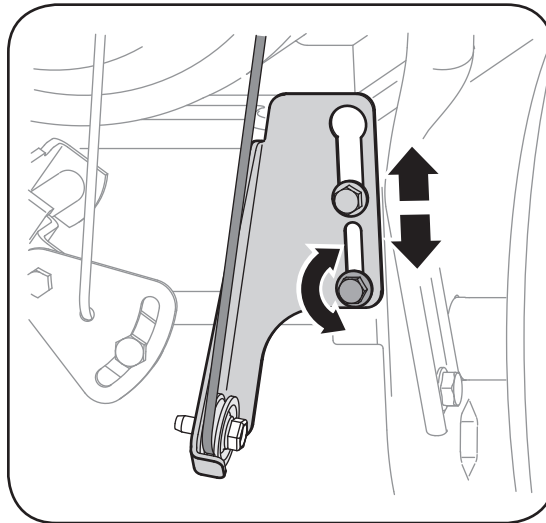

Figure 16

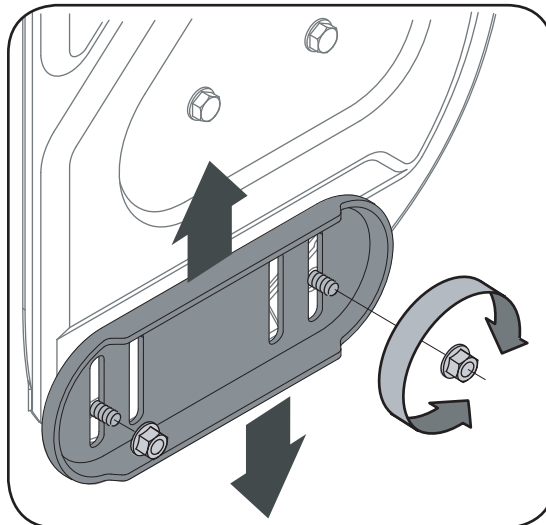

Figure 17

5

Making Adjustments



IMPORTANT

It is not recommended that you operate this snow thrower on gravel as loose gravel can be easily picked up and thrown by the auger causing personal injury or damage to the snow thrower.

If for some reason, you have to operate the snow thrower on gravel, keep the skid shoe in the highest position for maximum clearance between the ground and the shave plate.

6

Maintaining Your Snow Thrower



WARNING

Always stop engine, disconnect spark plug, and ground against engine before cleaning, lubricating or doing any kind of maintenance on your machine.



IMPORTANT

Avoid oil spillage on rubber friction wheel and aluminum drive plate.

Do not overfill the gear case. Damage to the seals could result.

IMPORTANT

NEVER replace the auger shear pins with standard pins. Any damage to the auger gearbox or other components, as a result of doing so, will NOT be covered by your snow thrower's warranty.

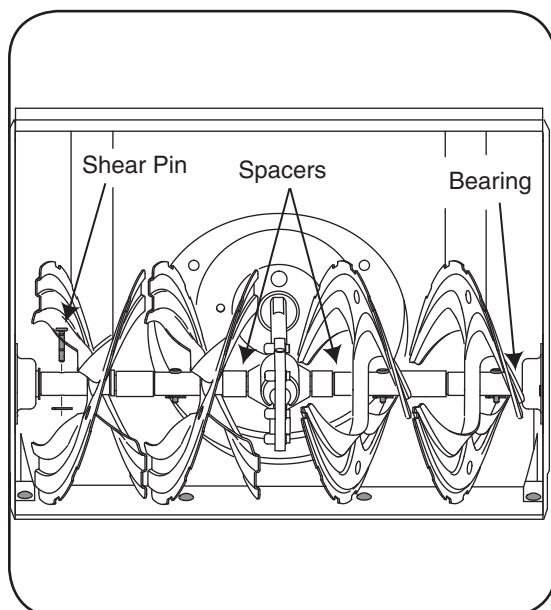

Figure 18

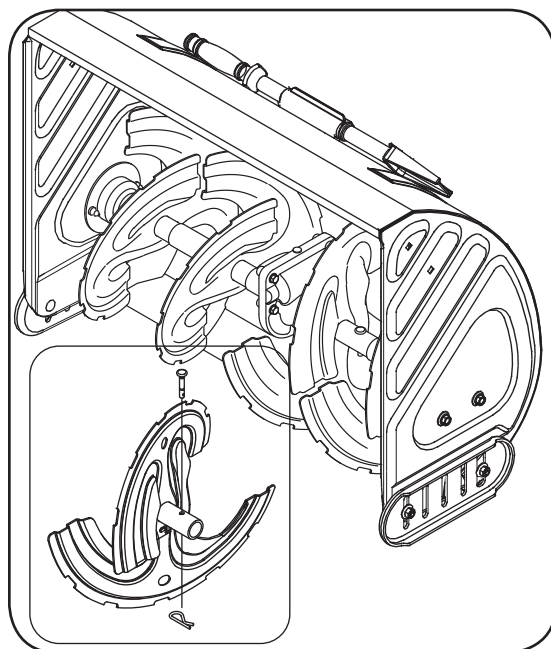

Figure 19



WARNING: Always stop engine and disconnect spark plug wire before performing any maintenance or adjustments. Always wear safety glasses during operation or while performing any adjustments or repairs.

General Recommendations

1. Always observe safety rules when performing any maintenance.
2. The warranty on this snow thrower does not cover items that have been subjected to operator abuse or negligence. To receive full value from warranty, operator must maintain the snow thrower as instructed here.

3. Some adjustments will have to be made periodically to maintain your unit properly.
4. Periodically check all fasteners and make sure these are tight.

Engine

Refer to the separate *Tecumseh* Engines manual packed with your unit for all engine maintenance.

Lubrication

1. **Drive Mechanism:** Once a season or after every 25 hours of operation, remove rear frame cover and lubricate any chains, sprockets, gears, bearings, and shafts with engine oil or lubricant spray.
2. **Hex Gear Shaft:** Once a season, lubricate the hex shaft with a penetrating oil, but not grease. Refer to Figure 24 on page 18.
3. **Gear Case:** The gear case is lubricated with grease at the factory and does not require regular lubrication. However, if disassembled for any reason, lubricate with 2 ounces of Shell Alvania™ grease (part # 737-0168). Before reassembling, remove old sealant and apply new sealant.
4. **Wheels:** Once a season, remove the bolt from each wheel and take the wheel off the axle. Apply a multipurpose automotive grease on the shaft before putting back the wheels.
5. **Auger Shaft:** At least once a season, remove the shear pins on auger shaft. Spray lubricant inside shaft, around the spacers. Also lubricate the flange bearings found at either end of the shaft. See Figure 18.
6. **Chute Directional Control:** Once a season, the spiral end on the chute directional control should be greased with multipurpose automotive grease.
7. **Pivot Points:** All pivoting points on the snow thrower should be lubricated with a light oil once a season.
8. **Drive/Auger Control Lock:** The cam on the ends of the control rods which interlock the drive and auger controls must be lubricated at least once a season or every 25 hours of operation using a multi-purpose automotive grease. The cam can be accessed beneath handle panel.
9. **Engine:** Refer to the separate *Tecumseh* Engines manual packed with your unit for all engine lubrication instructions.

Augers

The augers are secured to the spiral shaft with two shear pins and cotter pins. See Figure 19. If you hit a foreign object or ice jam, the snow thrower is designed so that the pins will shear.

1. If augers do not turn, check to see if pins have sheared.

6

Maintaining Your Snow Thrower

2. Replace the pins if needed. Two replacement shear pins and cotter pins have been provided with the snow thrower. Spray an oil lubricant into shaft before inserting new pins and securing with new cotter pins. See Figure 19.

Shave Plate and Skid Shoes

The shave plate and skid shoes on the bottom of the snow thrower are subject to wear. Check these periodically and replace as necessary.

Replacing Skid Shoe

1. Remove four carriage bolts and lock nuts which attach two skid shoes to the snow thrower on two sides. See Figure 20.
2. Reassemble new skid shoes with the same hardware. Make certain the skid shoes are adjusted to be level.

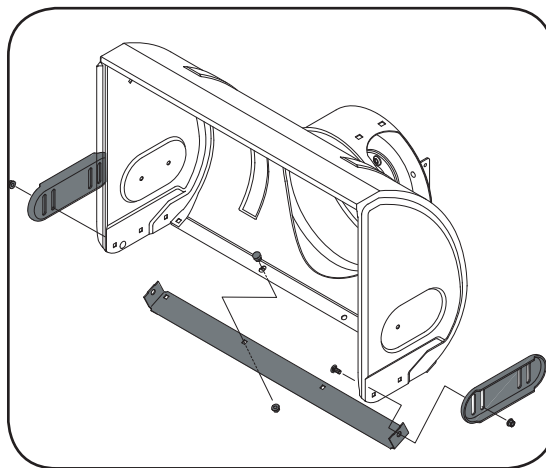

Figure 20

Replacing Shave Plate

1. After removing both skid shoes, remove four carriage bolts and lock nuts which attach shave plate to the snow thrower housing. See Figure 20.
2. Reassemble new shave plate, making sure heads of the carriage bolts are to the inside of the housing. Tighten securely. Re-install skid shoes.

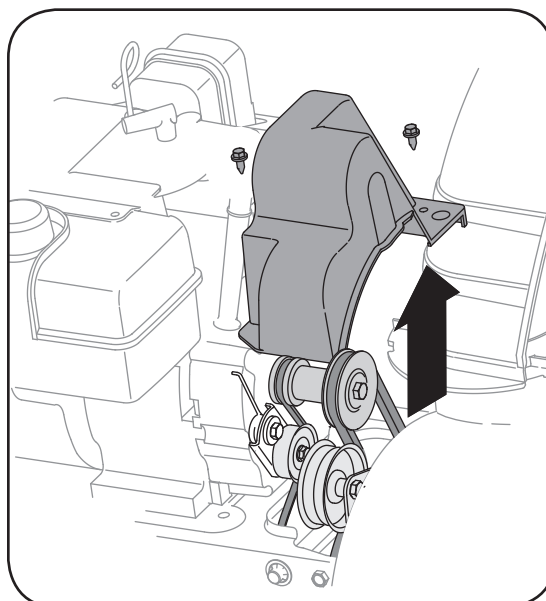

Figure 21

Replacing Belt

Check the condition of both auger belt and drive belt every 25 hours of snow thrower operation. Replace if either shows signs of wear and tear. To remove and replace either the auger belt or the drive belt, follow the steps below and then proceed to the specific steps listed under respective sub-headings.

1. Remove belt cover by removing the two self-tapping screws that secure it to the snow thrower housing. See Figure 21.
2. Drain the gasoline from the snow thrower, or place a piece of plastic under the gas cap. Carefully tip the snow thrower up and forward, so that it rests on the housing. Remove the self-tapping screws from the frame cover underneath the snow thrower and move the frame cover away. See Figure 22.

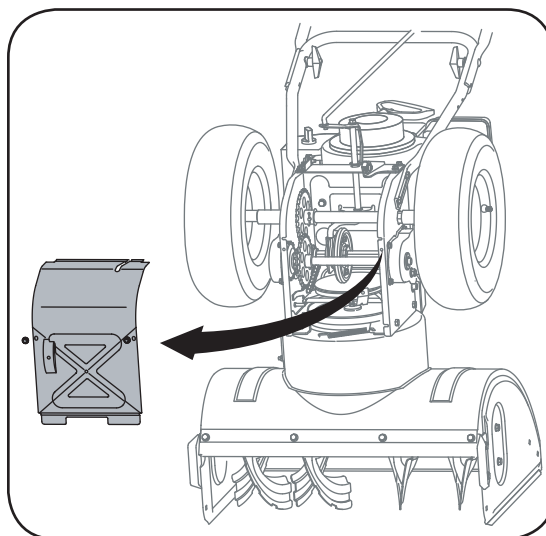

Figure 22

6

Maintaining Your Snow Thrower



WARNING

Always stop engine, disconnect spark plug, and ground against engine before cleaning, lubricating or doing any kind of maintenance on your machine.

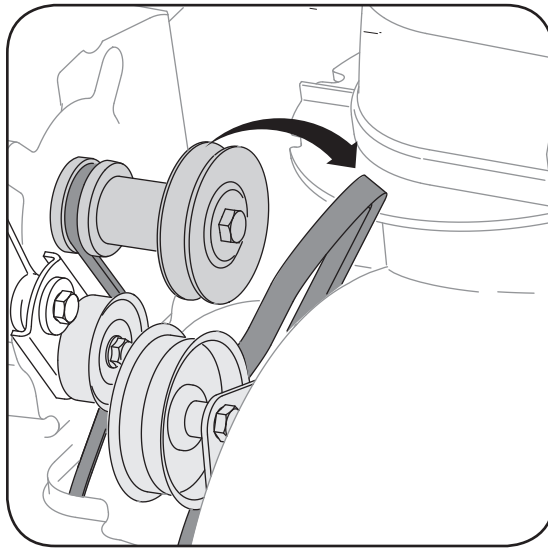

Figure 23

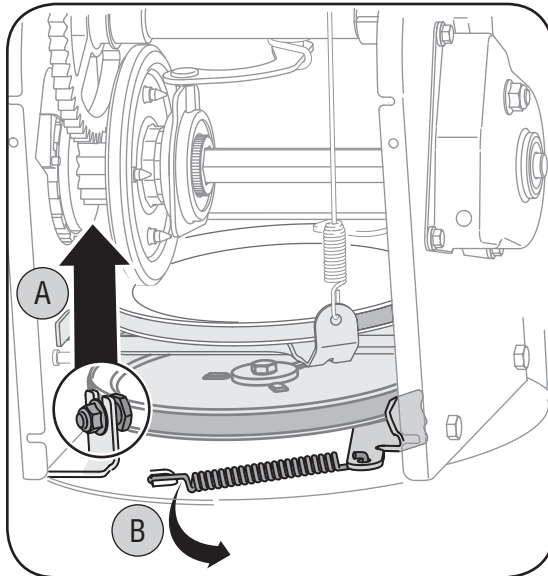

Figure 24

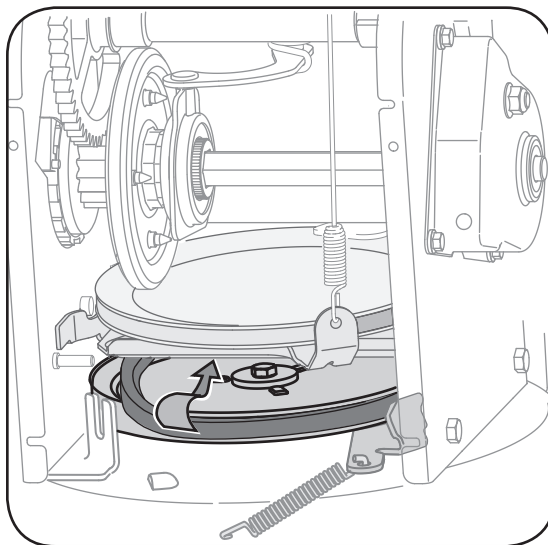

Figure 25

Auger Belt

1. Roll auger belt off the pulley as shown in Figure 23.
2. a. Turn the shoulder screw a half a turn and slide it out of the mounting bracket. See Figure 24.
b. Unhook spring to release tension on the auger belt. See Figure 24.
3. Remove old belt and replace with new belt wrapping it around the auger pulley. See Figure 25.
4. Re-insert shoulder screw into the mounting bracket and tighten to secure.
5. Wrap auger belt behind the idler. Reattach the spring to the bolt where it was earlier secured.
6. Re-install frame cover and flip the snow thrower back to the operating position.
7. Re-install auger belt around the engine pulley.
8. Re-install belt cover with the self-tapping screws removed earlier.

6

Maintaining Your Snow Thrower

Drive Belt

1. a. Grasp the idler pulley and pivot it toward the right. See Figure 26. Insert a screw driver through aligning holes in both the idler bracket and the engine. This will release tension on drive belt.
b. Roll the auger belt off the engine pulley.
c. Lift the drive belt off engine pulley. See Figure 26.
2. Slip the drive belt off the pulley and between friction wheel and friction wheel disc. See Figure 27.
3. Replace with new belt, first sliding it through the crank shaft, then working it around the groove of the drive pulley and finally wrapping it around the engine pulley from where the old belt was removed. Once the belt is firmly placed on the pulleys, make sure to remove the screwdriver from the idler.
4. Re-install auger belt on the engine pulley.
5. Re-attach frame cover on the snow thrower housing and put the equipment back to operating position. Re-attach belt cover with two self-tapping screws removed earlier.

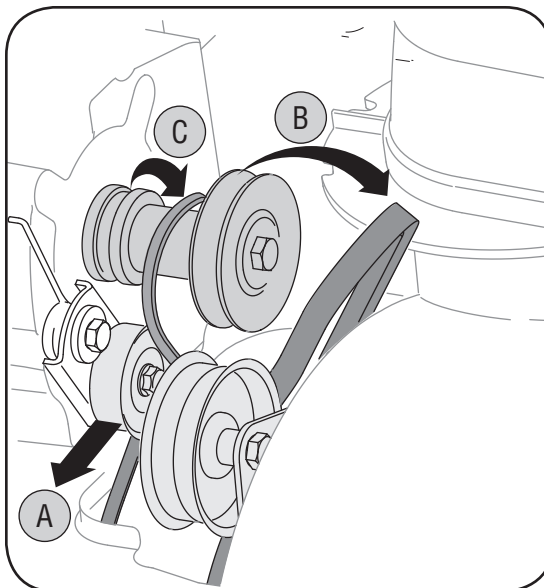

Figure 26

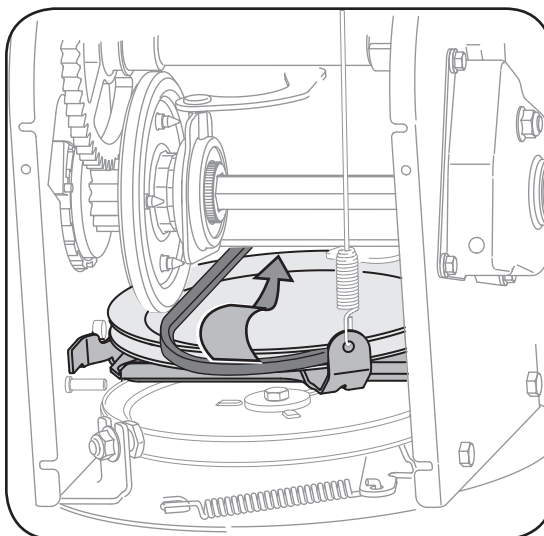

Figure 27

Friction Wheel Rubber

NOTE: Several components must be removed and special tools are required in order to replace this snow thrower's friction wheel rubber. See an authorized Cub Cadet Service Dealer if your friction wheel rubber needs to be replaced or phone Customer Support as instructed on page 2 for information on ordering a Cub Cadet Service Manual.

Also, refer to the **Drive Control** adjustment in the "Making Adjustments" section of this manual to adjust for wear on the friction wheel rubber.

7

Off-Season Storage



WARNING

Never store snow thrower with fuel in tank indoors or in poorly ventilated areas, where fuel fumes may reach an open flame, spark or pilot light as on a furnace, water heater, clothes dryer or gas appliance.

Drain fuel into an approved container outdoors, away from any open flame. Be certain engine is cool. Do not smoke. Fuel left in engine during warm weather deteriorates and will cause serious starting problems.

Do not drain carburetor if using fuel stabilizer. Never use engine or carburetor cleaning products in the fuel tank or permanent damage may occur.

If the snow thrower will not be used for 30 days or longer, or if it is the end of the snow season when the last possibility of snow is gone, the equipment needs to be stored properly. Follow storage instructions below to ensure top performance from the snow thrower for many more years.

Preparing Engine



WARNING: Never store snow thrower with fuel in tank indoors or in poorly ventilated areas, where fuel fumes may reach an open flame, spark or pilot light as on a furnace, water heater, clothes dryer or gas appliance.

NOTE: It is important to prevent gum deposits from forming in essential fuel system parts of the engine such as the carburetor, fuel filter, fuel hose or tank during storage.

CAUTION: Alcohol blended fuels (called gasohol or using ethanol or methanol) can attract moisture which leads to separation and formation of acids during storage. Acidic gas can damage the fuel system of an engine while in storage.

To avoid engine problems, the fuel system should be emptied before storage for 30 days or longer. Follow these instructions to prepare your snow thrower for storage:



WARNING: Drain fuel into an approved container outdoors, away from any open flame. Be certain engine is cool. Do not smoke. Fuel left in engine during warm weather deteriorates and will cause serious starting problems.

1. Remove all gasoline from the carburetor and the fuel tank to prevent gum deposits from forming on these parts and harming the engine.
2. Run the engine until the fuel tank is empty and it stops due to lack of fuel.
3. Drain carburetor by pressing upward on bowl drain, located below the carburetor cover (refer to the *Tecumseh* engine manual for more detailed instruction).



WARNING: Do not drain carburetor if using fuel stabilizer. Never use engine or carburetor cleaning products in the fuel tank or permanent damage may occur.

NOTE: Fuel stabilizer (such as STA-BIL) is an acceptable alternative in minimizing the formation of fuel gum deposits during storage. Add stabilizer to gasoline in fuel tank or storage container. Always follow mix ratio found on stabilizer container. Run engine at least 10 minutes after adding stabilizer to allow it to reach the carburetor. Do not drain carburetor if using fuel stabilizer.

4. Remove the spark plug and pour one (1) ounce of engine oil through the spark plug hole into the cylinder. Cover spark plug hole with a rag and crank the engine several times to distribute the oil. Replace spark plug.

NOTE: Refer to the *Tecumseh* engine manual for more information on preparing the snow thrower engine for storage.

Preparing Snow Thrower

1. When storing the snow thrower in an unventilated or metal storage shed, care should be taken to rustproof the equipment. Using a light oil or silicone, coat the equipment, especially any chains, springs, bearings and cables.
2. Remove all dirt from exterior of engine and equipment.
3. Follow lubrication recommendations on page 12.
4. Store equipment in a clean, dry area.

Problem	Cause	Remedy
Engine fails to start	<ol style="list-style-type: none"> 1. Choke not in ON position. 2. Spark plug wire disconnected. 3. Fuel tank empty or stale fuel. 4. Engine not primed. 5. Faulty spark plug. 6. Blocked fuel line. 7. Safety key not in ignition on engine. 	<ol style="list-style-type: none"> 1. Move choke to ON position. 2. Connect wire to spark plug. 3. Fill tank with clean, fresh gasoline. 4. Prime engine as instructed in "Operating Your Snow Thrower". 5. Clean, adjust gap, or replace. 6. Clean fuel line. 7. Insert key fully into the switch.
Engine runs erratic	<ol style="list-style-type: none"> 1. Unit running on CHOKE. 2. Blocked fuel line or stale fuel. 3. Water or dirt in fuel system. 4. Carburetor out of adjustment. 	<ol style="list-style-type: none"> 1. Move choke lever to OFF position. 2. Clean fuel line; fill tank with clean, fresh gasoline. 3. Drain fuel tank. Refill with fresh fuel. 4. Contact Cub Cadet Service Dealer.
Engine overheats	<ol style="list-style-type: none"> 1. Carburetor not adjusted properly. 	<ol style="list-style-type: none"> 1. Contact Cub Cadet Service Dealer.
Excessive Vibration	<ol style="list-style-type: none"> 1. Loose parts or damaged auger. 	<ol style="list-style-type: none"> 1. Stop engine immediately and disconnect spark plug wire. Tighten all bolts and nuts. If vibration continues, have unit serviced by a Cub Cadet Service Dealer.
Loss of power	<ol style="list-style-type: none"> 1. Spark plug wire loose. 2. Gas cap vent hole plugged. 3. Exhaust port plugged. 	<ol style="list-style-type: none"> 1. Connect and tighten spark plug wire. 2. Remove ice and snow from gas cap. Be certain vent hole is clear. 3. Contact Cub Cadet Service Dealer.
Unit fails to propel itself	<ol style="list-style-type: none"> 1. Drive control cable in need of adjustment. 2. Drive belt loose or damaged. 	<ol style="list-style-type: none"> 1. Adjust drive control cable. Refer to "Making Adjustments". 2. Replace drive belt.
Unit fails to discharge snow	<ol style="list-style-type: none"> 1. Chute assembly clogged. 2. Foreign object lodged in auger. 3. Auger control cable in need of adjustment. 4. Auger belt loose or damaged. 5. Shear pin(s) sheared. 	<ol style="list-style-type: none"> 1. Stop engine immediately and disconnect spark plug wire. Clean chute assembly and inside of auger housing with clean-out tool or a stick. 2. Stop engine immediately and disconnect spark plug wire. Remove object from auger with clean-out tool or a stick. 3. Refer to "Auger Control Test" on page 11. 4. Refer to Maintenance section. 5. Replace with new shear pin(s).

8

Trouble-Shooting



NOTE: This section addresses minor service issues. For further details, contact your nearest Cub Cadet service dealer or call 1-877-282-8684.

Model 528 SWE

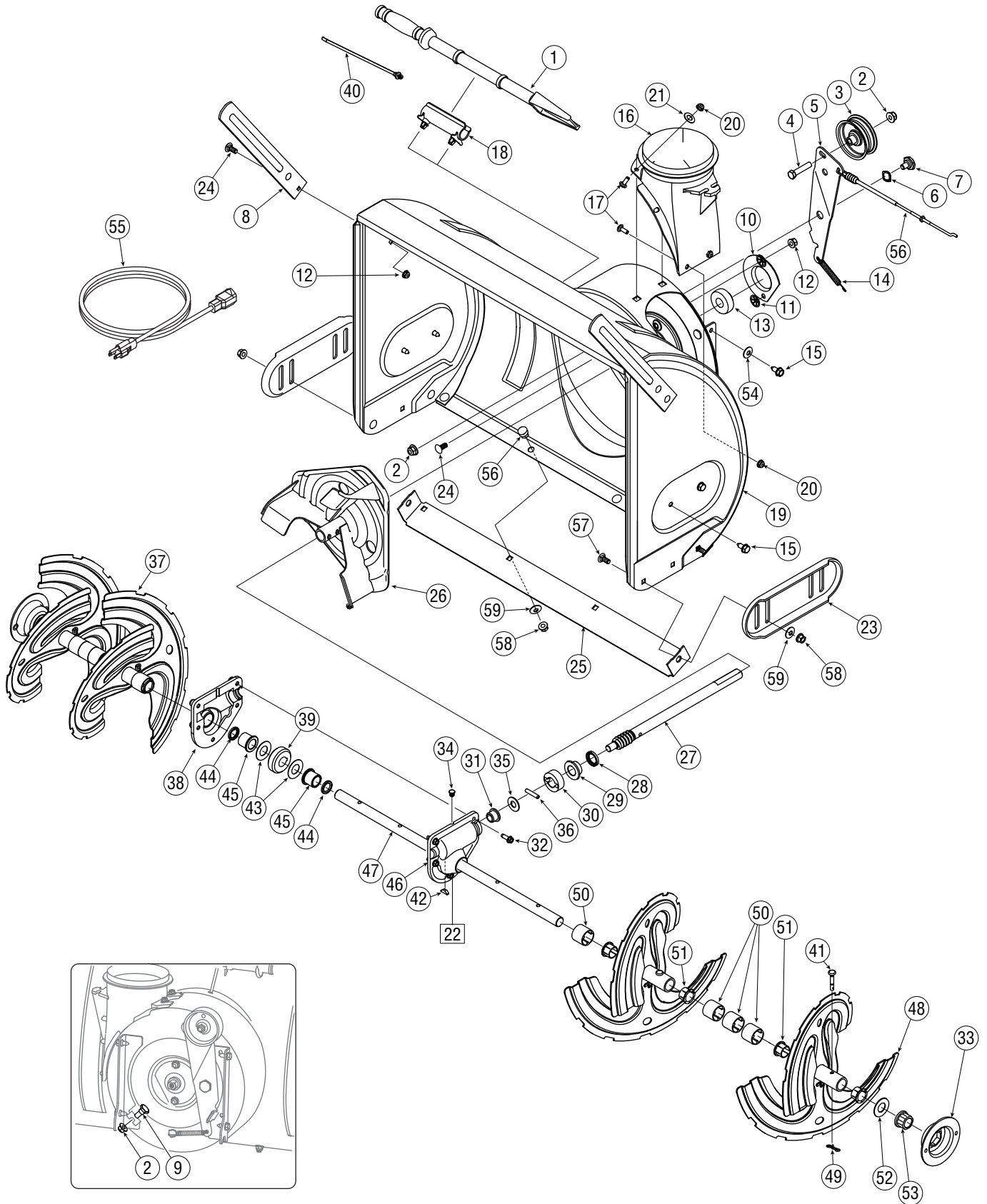

1.	731-2643	Clean-Out Tool
2.	712-04065	Flange Lock Nut
3.	756-0981A	Flat Idler Pulley
4.	710-0347	Hex Bolt, 3/8-16 x 1.75
5.	790-00080	Auger Idler Bracket
6.	736-0174	Wave Washer
7.	738-0281	Shoulder Screw
8.	790-00181	Blade Guide
9.	738-0143	Shoulder Screw
10.	790-00075	Bearing Housing
11.	726-04012	Push Nut
12.	712-04063	Flange Lock Nut, 5/16-18
13.	741-0309	Ball Bearing
14.	732-0611	Extension Spring
15.	710-0604A	AB Screw, 5/16-18 x 0.625
16.	731-04705	Chute Adapter
17.	710-0703	Carriage Screw, 1/4-20 x 0.75
18.	731-2635	Clean-out Tool Mtg. Bracket
19.	684-04073	Auger Housing Assembly: 28"
20.	712-04064	Flange Lock Nut, 1/4-20
21.	736-0463	Flat Washer
22.	618-04173	Gearbox Assembly Complete
23.	790-00141	Slide Shoe
24.	710-0451	Carriage Bolt
25.	790-00145	Shave Plate
26.	684-04057	Impeller Assembly
27.	717-04126	Worm Shaft
28.	721-0327	Oil Seal
29.	741-0662	Flange Bearing
30.	718-04071	Thrust Collar

31.	741-0663	Flange Bearing
32.	710-0642	TT Screw, 1/4-20 x 0.75
33.	790-00087A	Bearing Housing
34.	721-0325	Plug
35.	736-3084	Flat Washer
36.	715-04021	Dowel Pin
37.	684-04108	Spiral Assembly- RH
38.	618-0123	Reducer Hsg.-RH (Incl Ref. 44-45)
39.	717-0528A	Worm Gear, 20T
40.	725-0157	Cable Tie
41.	738-04124A	Shear Pin
42.	714-0161	Key
43.	736-0351	Flat Washer
44.	721-0179	Oil Seal
45.	741-0661A	Flange Bearing
46.	618-0124	Reducer Hsg.-LH (Incl Ref. 44-45)
47.	711-04283	Auger Axle
48.	684-04107	Spiral Assembly- LH
49.	714-04040	Bow Tie Cotter Pin
50.	731-04870	Spacer
51.	741-0493A	Flange Bushing
52.	736-0188	Flat Washer
53.	741-0245	Hex Flange Bearing
54.	736-0242	Bell Washer
55.	629-0071	Extension Cord
56.	746-04230	Auger Clutch Cable
57.	710-04525	Carriage Bolt, 5/16-18 x .750
58.	712-04103	Hex Nut, 5/16-18
59.	736-04216	Bell Washer, .340 x .872 x .060

9

Parts List



To order replacement parts, call the Customer Dealer Referral Line at 1-877-282-8684, or visit www.cubcadet.com to find the nearest Cub Cadet service dealer in your area.

Model 528 SWE

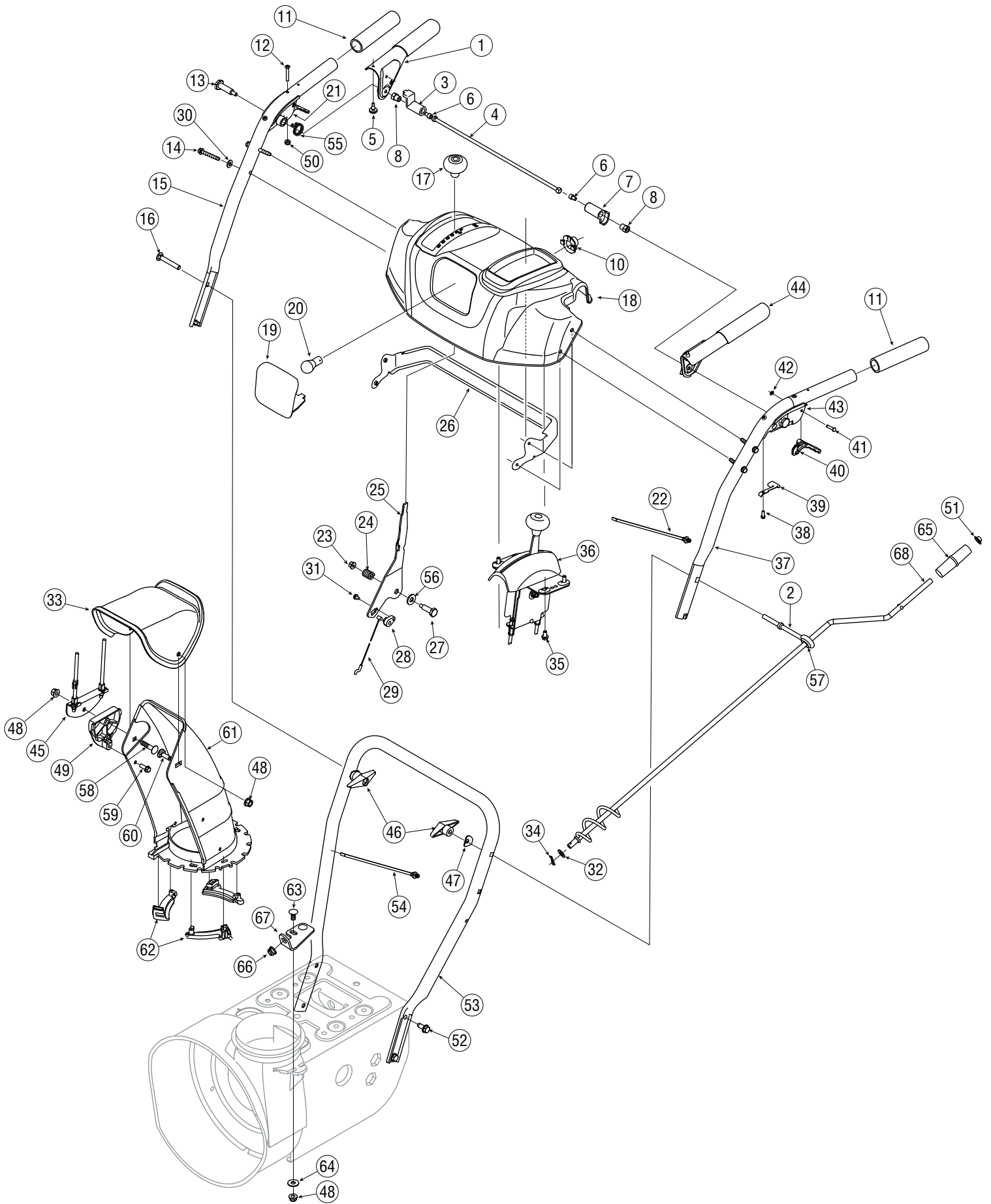

1.	684-04106A	Handle Engagement Assembly RH
2.	747-04263	Eye Bolt
3.	731-04894A	Lock Plate
4.	711-04287	Pivot Rod
5.	735-0199A	Rubber Bumper
6.	710-04354	Screw, 1/4-20 x.375
7.	731-04896A	Clutch Lock Cam
8.	712-04081A	Shoulder Nut, 1/4-20
9.	725-04216A	Wire Harness (Not Shown)
10.	725-1649	Light Socket
11.	720-0274	Handle Grip
12.	710-1233	Screw, #10-24 x 0.375
13.	738-04122	Shoulder Screw, 1/4-20 x 1.345
14.	710-1026	Screw, 1/4-20 x 1.750
15.	749-04190	Upper Handle RH
16.	710-0449	Carriage Screw, 5/16-18 x 2.25
17.	720-04039	Shift Knob
18.	631-04183	Handle Panel (Includes Ref. #19)
19.	731-05320	Lens
20.	725-04213	Lamp
21.	731-04784A	Handle Clutch Lock - RH
22.	725-0157	Cable Tie
23.	712-04064	Flange Lock Nut, 1/4-20
24.	732-0193	Compression Spring
25.	790-00203	Shift Lever
26.	790-00140	Panel Bracket
27.	738-04125	Shoulder Screw
28.	746-0605	Cable Barrel Holder
29.	746-04227	Speed Selector Cable
30.	736-0463	Flat Washer, .25 x .630 x .0515
31.	710-0224	Screw, #10-16 x .500
32.	736-0185	Flat Washer, .375 x .738 x .063
33.	731-04427A	Upper Chute
34.	714-0104	Cotter Pin
35.	710-04187	Hi-Lo Screw, 1/4-15 x 0.5

36.	684-04117	2-Way Chute Control™ Assembly
37.	749-04191	Upper Handle LH
38.	710-04326	Screw, #8-16 x 0.50
39.	732-04219	Clutch Lock Spring
40.	731-04954	Steering Control
41.	738-04126	Pin, 3/16
42.	716-04036	E Ring
43.	731-04785	Handle Clutch Lock - LH
44.	684-04110A	Handle Engagement Assembly LH
45.	784-5594	Cable Bracket
46.	720-0284	Handle Knob Assembly
47.	736-0451	Saddle Washer
48.	712-04063	Flange Lock Nut, 5/16-18
49.	731-1313C	Chute Tilt Cable Guide
50.	712-0161	Hex Lock Nut, #10-24
51.	726-0100	Push Cap
52.	710-0726	AB Screw, 5/16-12 x 0.75
53.	749-04138	Lower Handle
54.	726-0470	Cable Tie
55.	732-04238	Torsion Spring
56.	736-0262	Flat Washer
57.	735-0234	Rubber Grommet
58.	710-0262	Carriage Bolt, 5/16-18 x 1.50
59.	710-0895	Hi-Lo Screw, 1/4-15 x .75
60.	710-04071	Carriage Bolt, 5/16-18 x 1.0
61.	631-04131A	Lower Chute Ass'y (Incl. Ref. #62)
	731-04912A	Lower Chute Only
62.	731-04869	Flange Keeper
63.	710-0267	Carriage Screw, 5/16-18 x 1.00
64.	736-0159	Flat Washer, .349 x .879 x .063
65.	720-0201A	Chute Directional Control Knob
66.	741-0475	Plastic Bushing
67.	784-5647	Chute Directional Control Bracket
68.	684-04104	Chute Directional Control

9

Parts List



To order replacement parts, call the Customer Dealer Referral Line at 1-877-282-8684, or visit www.cubcadet.com to find the nearest Cub Cadet service dealer in your area.

Model 528 SWE

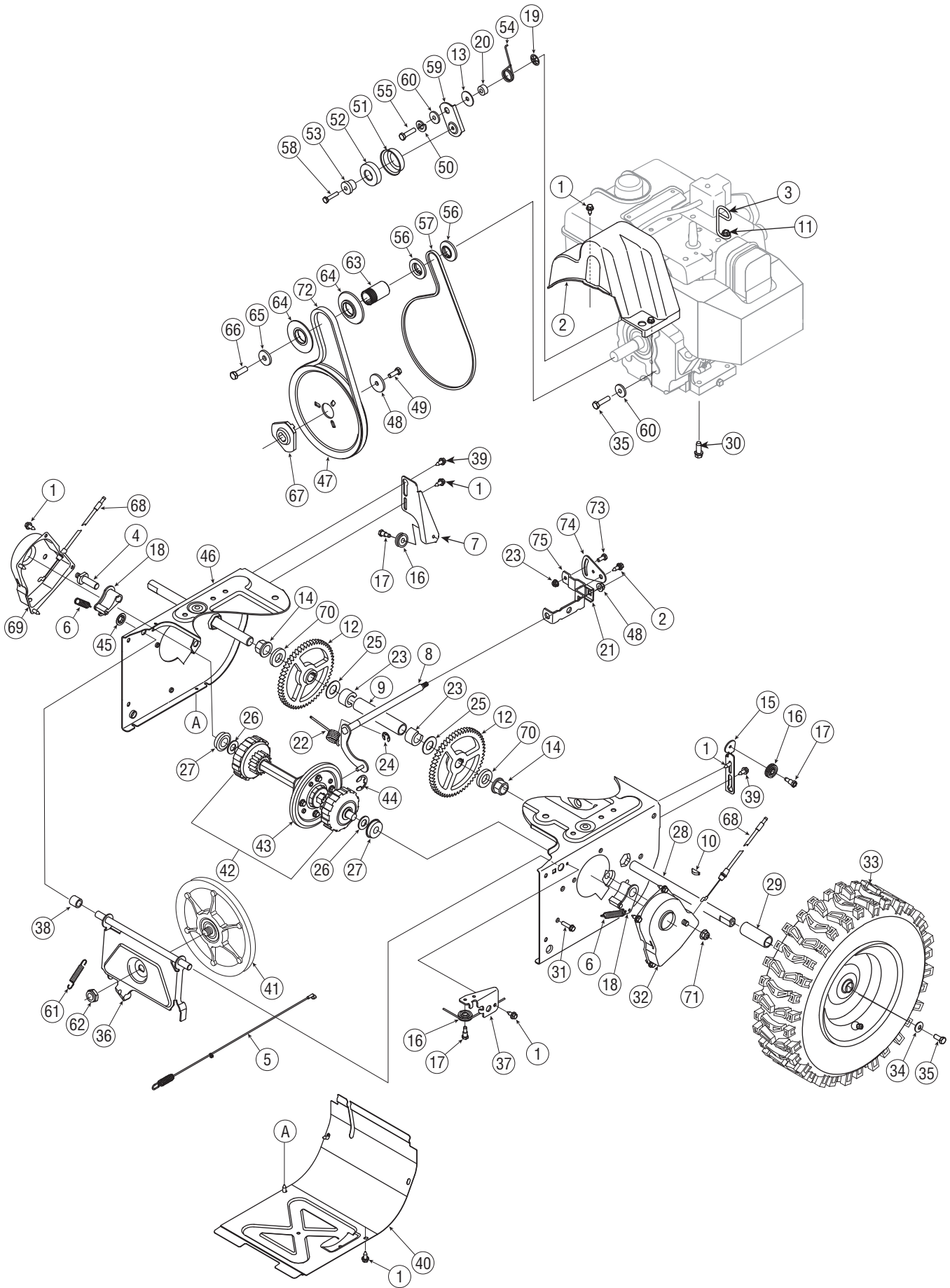

1.	710-1652	AB Screw, 1/4-20 x 0.625
2.	731-04792A	Belt Cover
3.	732-0705	Cable Guide
4.	711-1268B	Actuator Shaft
5.	746-04229	Drive Clutch Cable
6.	732-0209	Extension Spring
7.	790-00207	Drive Clutch Cable Guide Bracket
8.	684-04156	Shift Rod Assembly
9.	750-04474	Axle Support Tube
10.	714-0126	Hi Pro Key
11.	710-0602	TT Screw, 5/16-18 x 1.00
12.	717-04210	Gear, 56T
13.	736-0362	Flat Washer
14.	741-0245	Hex Flange Bearing
15.	790-00206	Auger Clutch Cable Guide Bracket
16.	756-0625	Cable Roller
17.	738-0924	C Screw, 1/4-28 x 0.375
18.	618-04288	Dogg Assembly - LH
—	618-04287	Dogg Assembly - RH
19.	726-04012	Push-on Nut
20.	750-04477	Spacer
21.	790-00156	Shift Bracket Spacer
22.	732-04311	Torsion Spring, .750ID x .968 Lg.
23.	731-05297	Spacer
24.	716-0104	E Ring
25.	736-0188	Flat Washer, .76 x 1.49 x .06
26.	736-0626	Flat Washer
27.	741-04076	Ball Bearing
28.	738-04180	Axle
29.	731-04873	Spacer
30.	710-0654A	TT Sems Screw, 3/8-16 x 1.0
31.	710-0788	TT Screw, 1/4-20 x 1.0
32.	790-00185	Shaft Retainer - LH
33.	634-04136	Wheel Complete - LH
	634-04137	Wheel Complete - RH
34.	736-0242	Bell Washer
35.	710-0627	Hex Bolt, 5/16-24 x 0.75
36.	684-04154	Friction Wheel Support Brkt. Assy.
37.	790-00096	Auger Cable Guide Bracket
38.	748-0190	Spacer

39.	738-04184	Shoulder Screw
40.	790-00226	Frame Cover
41.	656-04025	Friction Wheel Disc Assembly
42.	618-04283	Drive Shaft Assembly
43.	684-04159	Friction Wheel Assembly
—	735-04054	Friction Wheel Rubber Only
44.	716-0136	Retainer Ring
45.	726-0221	Speed Nut
46.	790-00183	Wheel Drive Frame
47.	756-04109	Auger Pulley
48.	736-0505	Flat Washer
49.	710-1245B	Hex Bolt, 5/16-24 x 0.875
50.	712-04064	Flange Lock Nut, 1/4-20
51.	790-00230	Bearing Sleeve
52.	741-0919	Ball Bearing
53.	750-04571	Spacer
54.	732-04308	Torsion Spring
55.	710-04520	Hex Screw, 5/16-24 x 1.25
56.	756-04179	Pulley Half
57.	754-04088	V-Belt, 2L x 33
58.	710-0106	Hex Screw, 1/4-20 x 1.25
59.	790-00208	Drive Clutch Idler Bracket
60.	748-04097	Shoulder Spacer
61.	732-0264	Extension Spring
62.	712-0413	Jam Lock Nut, 5/8-18
63.	750-04303	Spacer
64.	756-04113	Pulley Half
65.	736-0247	Flat Washer
66.	710-0191	Hex Bolt, 3/8-24 x 1.25
67.	748-04053	Pulley Adapter
68.	746-0956A	Steering Cable
69.	790-00186	Shaft Retainer - RH
70.	750-0767	Axle Spacer
71.	712-04065	Flange Lock Nut, 3/8-16
72.	754-04050	V-Belt,.500 x 35.00 Lg
73.	710-0751	Hex Screw, 1/4-20 x .620
74.	790-00217	Speed Selector Pivot Bracket
75.	790-00218	Speed Selector Shift Bracket
—	723-0608	Tire Chains (If Equipped)

9

Parts List



To order replacement parts, call the Customer Dealer Referral Line at 1-877-282-8684, or visit www.cubcadet.com to find the nearest Cub Cadet service dealer in your area.

NOTES:

Use this page to make notes and write down important information.



NOTES:

Use this page to make notes and write down important information.



NOTES:

Use this page to make notes and write down important information.



MANUFACTURER'S LIMITED COMMERCIAL WARRANTY FOR:



The limited warranty set forth below is given by Cub Cadet LLC with respect to new merchandise used for commercial purposes and purchased and used in the United States and/or its territories and possessions, and by MTD Products Limited with respect to new merchandise purchased and used in Canada and/or its territories and possessions (either entity respectively, "Cub Cadet").

"Cub Cadet" warrants this product (excluding its normal wear parts as described below) against defects in material and workmanship for a period of one (1) year commencing on the date of original purchase and will, at its option, repair or replace, free of charge, any part found to be defective in materials or workmanship. This limited warranty shall only apply if this product has been operated and maintained in accordance with the Operator's Manual furnished with the product, and has not been subject to misuse, abuse, neglect, accident, improper maintenance, alteration, vandalism, theft, fire, water, or damage because of other peril or natural disaster. Damage resulting from the installation or use of any part, accessory or attachment not approved by Cub Cadet for use with the product(s) covered by this manual will void your warranty as to any resulting damage.

Normal wear parts are warranted to be free from defects in material and workmanship for a period of thirty (30) days from the date of purchase. Normal wear parts include, but are not limited to items such as: batteries, belts, blades, blade adapters, grass bags, rider deck wheels, seats, snow thrower skid shoes, friction wheels, shave plates, auger spiral rubber and tires.

HOW TO OBTAIN SERVICE: Warranty service is available, WITH PROOF OF PURCHASE, through your local authorized service dealer. To locate the dealer in your area:

In the U.S.A.

To locate the dealer in your area, check your Yellow Pages, or contact Cub Cadet LLC at P.O. Box 361131, Cleveland, Ohio 44136-0019, or call 1-877-282-8684, or log on to our Web site at www.cubcadet.com.

In Canada

Contact MTD Products Limited, Kitchener, ON N2G 4J1, or call 1-800-668-1238 or log on to our Web site at www.mtdcanada.com.

This limited warranty does **not** provide coverage in the following cases:

- a. The engine or component parts thereof. These items may carry a separate manufacturer's warranty. Refer to applicable manufacturer's warranty for terms and conditions.
- b. Log splitter pumps, valves, and cylinders have a separate one- year warranty.
- c. Routine maintenance items such as lubricants, filters, blade sharpening, tune-ups, brake adjustments, clutch adjustments, deck adjustments, and normal deterioration of the exterior finish due to use or exposure.
- d. Service completed by someone other than an authorized service dealer.
- e. Cub Cadet does not extend any warranty for products sold or exported outside of the United States and/or Canada, and their respective possessions and territories, except those sold through Cub Cadet's authorized channels of export distribution.
- f. Replacement parts that are not genuine Cub Cadet parts.
- g. Transportation charges and service calls.

No implied warranty, including any implied warranty of merchantability of fitness for a particular purpose, applies after the applicable period of express written warranty above as to the parts as identified. No other express warranty, whether written or oral, except as mentioned above, given by any person or entity, including a dealer or retailer, with respect to any product, shall bind Cub Cadet. During the period of the warranty, the exclusive remedy is repair or replacement of the product as set forth above.

The provisions as set forth in this warranty provide the sole and exclusive remedy arising from the sale. Cub Cadet shall not be liable for incidental or consequential loss or damage including, without limitation, expenses incurred for substitute or replacement lawn care services or for rental expenses to temporarily replace a warranted product.

Some jurisdictions do not allow the exclusion or limitation of incidental or consequential damages, or limitations on how long an implied warranty lasts, so the above exclusions or limitations may not apply to you.

In no event shall recovery of any kind be greater than the amount of the purchase price of the product sold. **Alteration of safety features of the product shall void this warranty.** You assume the risk and liability for loss, damage, or injury to you and your property and/or to others and their property arising out of the misuse or inability to use the product.

This limited warranty shall not extend to anyone other than the original purchaser or to the person for whom it was purchased as a gift.

HOW LOCAL LAWS RELATE TO THIS WARRANTY: This limited warranty gives you specific legal rights, and you may also have other rights that vary in different jurisdictions.

IMPORTANT: Owner must present Original Proof of Purchase to obtain warranty coverage.

**Cub Cadet LLC, P.O. BOX 361131 CLEVELAND, OHIO 44136-0019; Phone: 1-877-282-8684
MTD Canada Limited - KITCHENER, ON N2G 4J1; Phone 1-800-668-1238**

MANUFACTURER'S LIMITED WARRANTY FOR



The limited warranty set forth below is given by Cub Cadet LLC with respect to new merchandise purchased and used in the United States, its possessions and territories, and by MTD Products Limited with respect to new merchandise purchased and used in Canada and/or its territories and possessions.

“Cub Cadet” warrants this product against defects in material and workmanship for a period of three (3) years commencing on the date of original purchase and will, at its option, repair or replace, free of charge, any part found to be defective in materials or workmanship. This limited warranty shall only apply if this product has been operated and maintained in accordance with the Operator’s Manual furnished with the product, and has not been subject to misuse, abuse, commercial use, neglect, accident, improper maintenance, alteration, vandalism, theft, fire, water, or damage because of other peril or natural disaster. Damage resulting from the installation or use of any part, accessory or attachment not approved by Cub Cadet for use with the product(s) covered by this manual will void your warranty as to any resulting damage.

Normal wear parts are warranted to be free from defects in material and workmanship for a period of thirty (30) days from the date of purchase. Normal wear parts include, but are not limited to items such as: batteries, belts, blades, blade adapters, grass bags, rider deck wheels, seats, snow thrower skid shoes, shave plates, auger spiral rubber and tires.

HOW TO OBTAIN SERVICE: Warranty service is available, WITH PROOF OF PURCHASE, through your local authorized service dealer. To locate the dealer in your area:

In the U.S.A.

To locate the dealer in your area, check your Yellow Pages, or contact Cub Cadet LLC at P.O. Box 361131, Cleveland, Ohio 44136-0019, or call 1-877-282-8684, or log on to our Web site at www.cubcadet.com.

In Canada

Contact MTD Products Limited, Kitchener, ON N2G 4J1, or call 1-800-668-1238 or log on to our Web site at www.mtdcanada.com.

This limited warranty does not provide coverage in the following cases:

- a. The engine or component parts thereof. These items may carry a separate manufacturer’s warranty. Refer to applicable manufacturer’s warranty for terms and conditions.
- b. Log splitter pumps, valves, and cylinders have a separate one year warranty.

- c. Routine maintenance items such as lubricants, filters, blade sharpening, tune-ups, brake adjustments, clutch adjustments, deck adjustments, and normal deterioration of the exterior finish due to use or exposure.
- d. Cub Cadet does not extend any warranty for products sold or exported outside of the United States and/or Canada, and their respective possessions and territories, except those sold through Cub Cadet’s authorized channels of export distribution.
- e. Replacement parts that are not genuine Cub Cadet parts.
- f. Service completed by someone other than an authorized service dealer.
- g. Transportation charges and service calls.

No implied warranty, including any implied warranty of merchantability of fitness for a particular purpose, applies after the applicable period of express written warranty above as to the parts as identified. No other express warranty, whether written or oral, except as mentioned above, given by any person or entity, including a dealer or retailer, with respect to any product, shall bind Cub Cadet. During the period of the warranty, the exclusive remedy is repair or replacement of the product as set forth above.

The provisions as set forth in this warranty provide the sole and exclusive remedy arising from the sale. Cub Cadet shall not be liable for incidental or consequential loss or damage including, without limitation, expenses incurred for substitute or replacement lawn care services or for rental expenses to temporarily replace a warranted product.

Some states do not allow the exclusion or limitation of incidental or consequential damages, or limitations on how long an implied warranty lasts, so the above exclusions or limitations may not apply to you.

In no event shall recovery of any kind be greater than the amount of the purchase price of the product sold. **Alteration of safety features of the product shall void this warranty.** You assume the risk and liability for loss, damage, or injury to you and your property and/or to others and their property arising out of the misuse or inability to use the product.

This limited warranty shall not extend to anyone other than the original purchaser or to the person for whom it was purchased as a gift.

HOW STATE LAW RELATES TO THIS WARRANTY: This limited warranty gives you specific legal rights, and you may also have other rights that vary in different jurisdictions.

IMPORTANT: Owner must present Original Proof of Purchase to obtain warranty coverage.