

Cub Cadet[®]

Power Equipment

Service Manual

LAWN TRACTORS

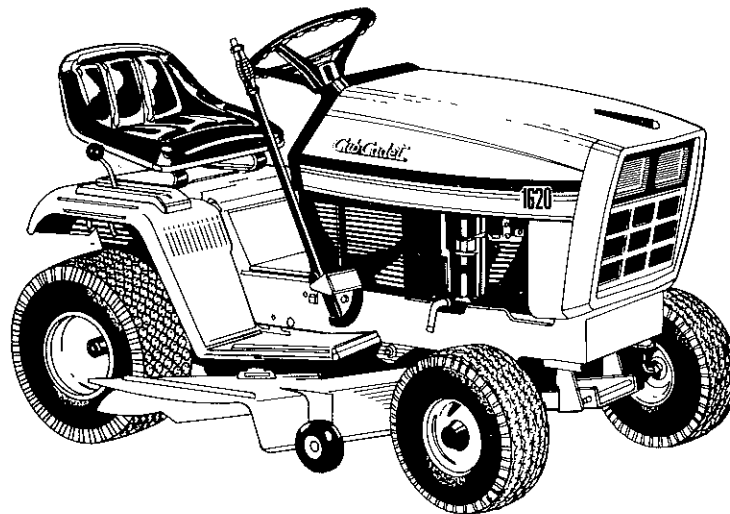

MODEL NUMBERS

**805, 1015, 1020, 1105, 1110, 1215,
1220, 1315, 1320, 1405, 1415, 1420,
1605, 1610, 1615, 1620, 1715 and 1720**

Thank you for purchasing an American-built product.

CUB CADET CORPORATION • P.O. BOX 360930 • CLEVELAND, OHIO 44136

PRINTED IN U.S.A.

FORM NO. 772-3870
(R900701)

Section 1

ENGINE

Contents

Special Torques	1-1
Engine Removal	1-2
Installation	1-9
Electrical System	
General Information and Functions	1-10
Electrical Wiring Diagram (Serial Number 107,999 and below)	1-11
Electrical Wiring Diagram (Serial Number 108,000 and above)	1-12
Electrical Wiring Diagram (1988)	1-13
Electrical Wiring Diagram (1989)	1-14
Electrical Wiring Diagram (1990)	1-15
Engine Removal (Model Number 1415, 1420, 1715 and 1720)	1-16
Battery Removal, 1989 Units	1-20

ENGINE REMOVAL

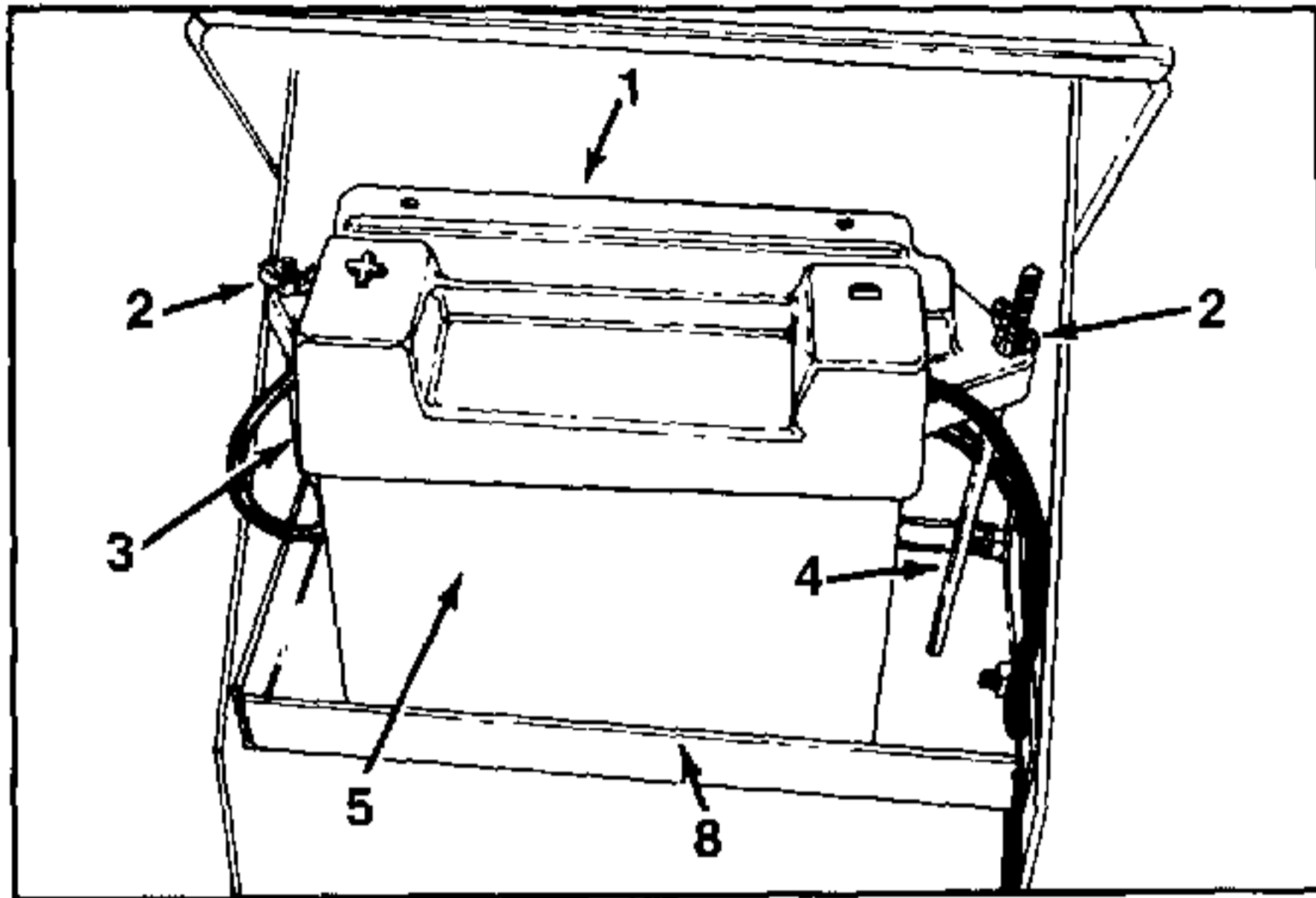

FIGURE 1.

1. Remove the battery cover (Ref. 1), wing nuts (Ref. 2) and battery hold down rods (Ref. 3 and 4). See figure 1.

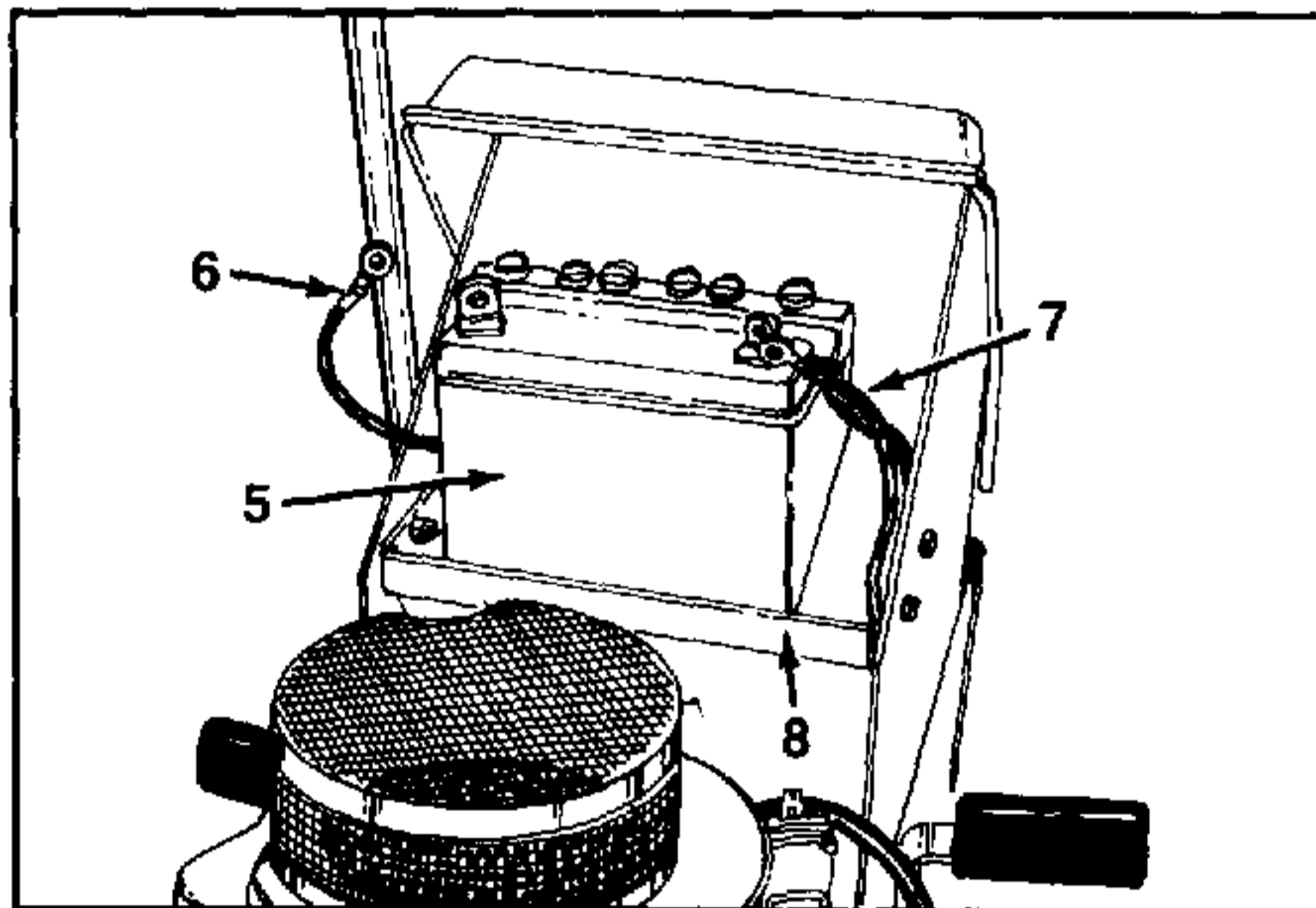

FIGURE 2.

2. Disconnect the battery cables **negative cable first** (Ref. 6 and 7) from battery post. See figure 2.

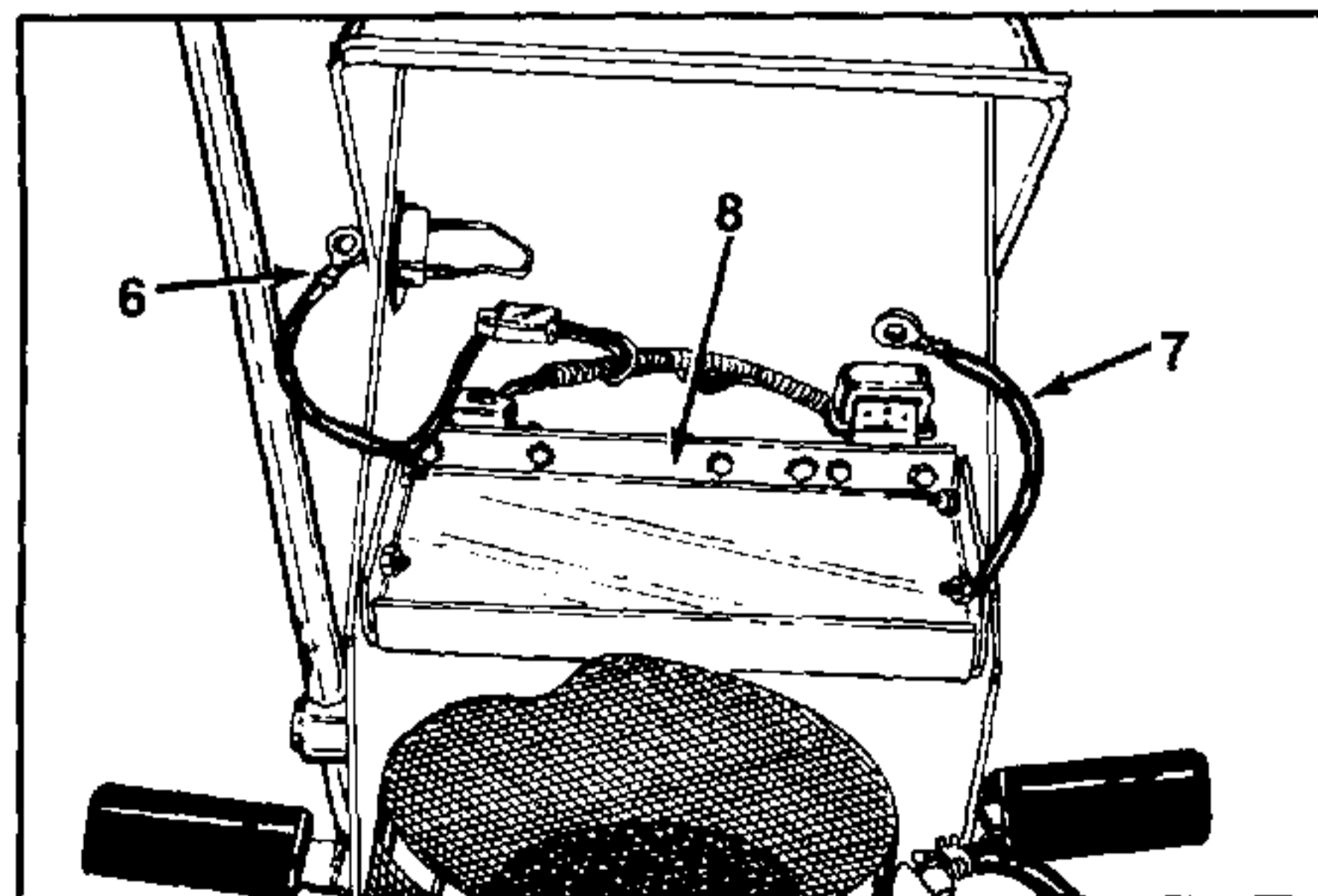

FIGURE 3.

3. Lift out the battery (Ref. 5) from the battery tray (Ref. 8). See figures 2 and 3.

- | |
|---------------------------|
| 1. Battery Cover |
| 2. Wing Nuts |
| 3. Battery Hold Down Rod |
| 4. Battery Hold Down Rod |
| 5. Battery |
| 6. Battery Cable—Positive |
| 7. Battery Cable—Negative |
| 8. Battery Tray |

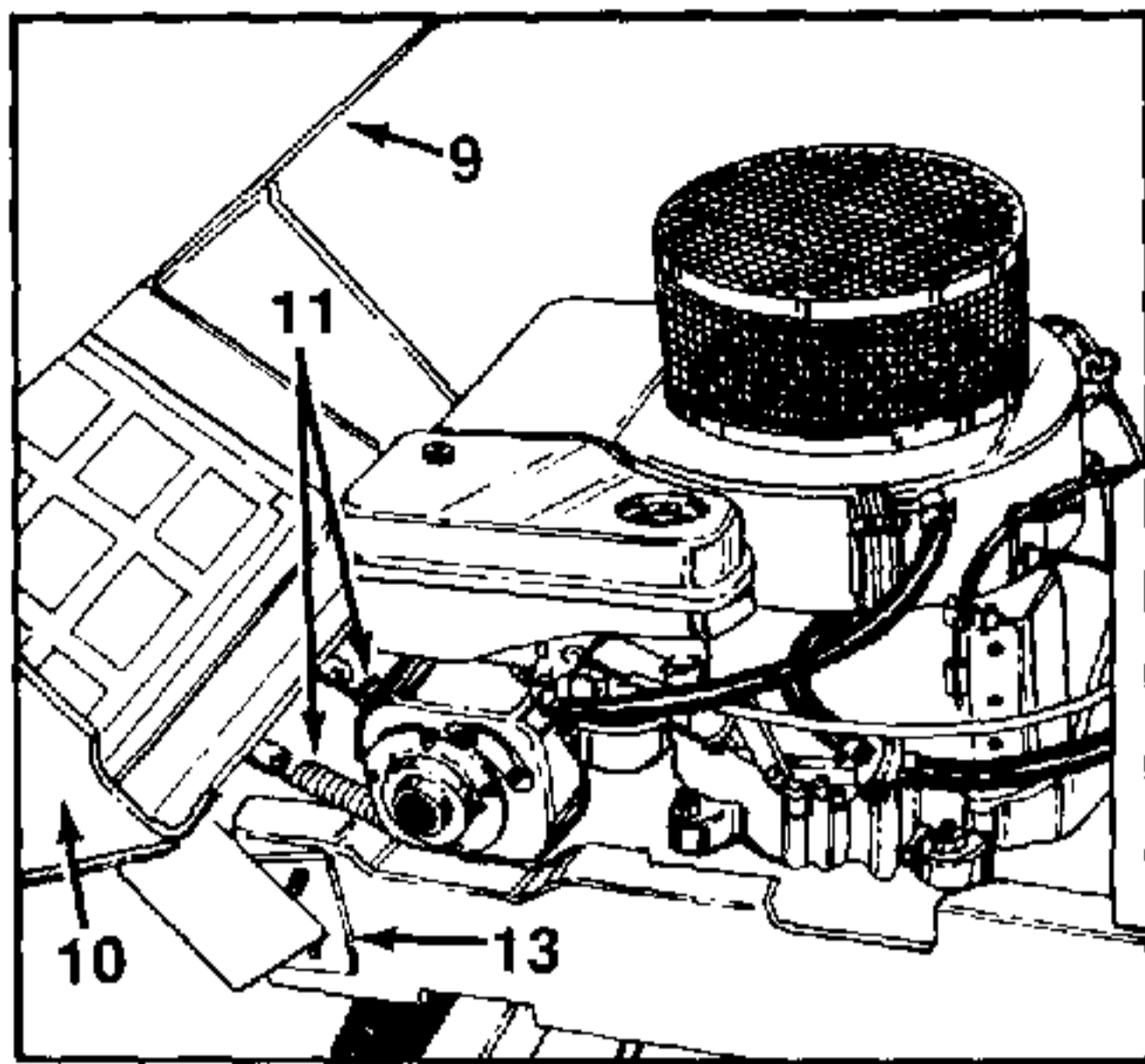

FIGURE 4.

4. Remove the hood (Ref. 9) and grille (Ref. 10) by removing the two extension springs (Ref. 11) from the grille and front chassis (Ref. 15). See figures 4 and 5.

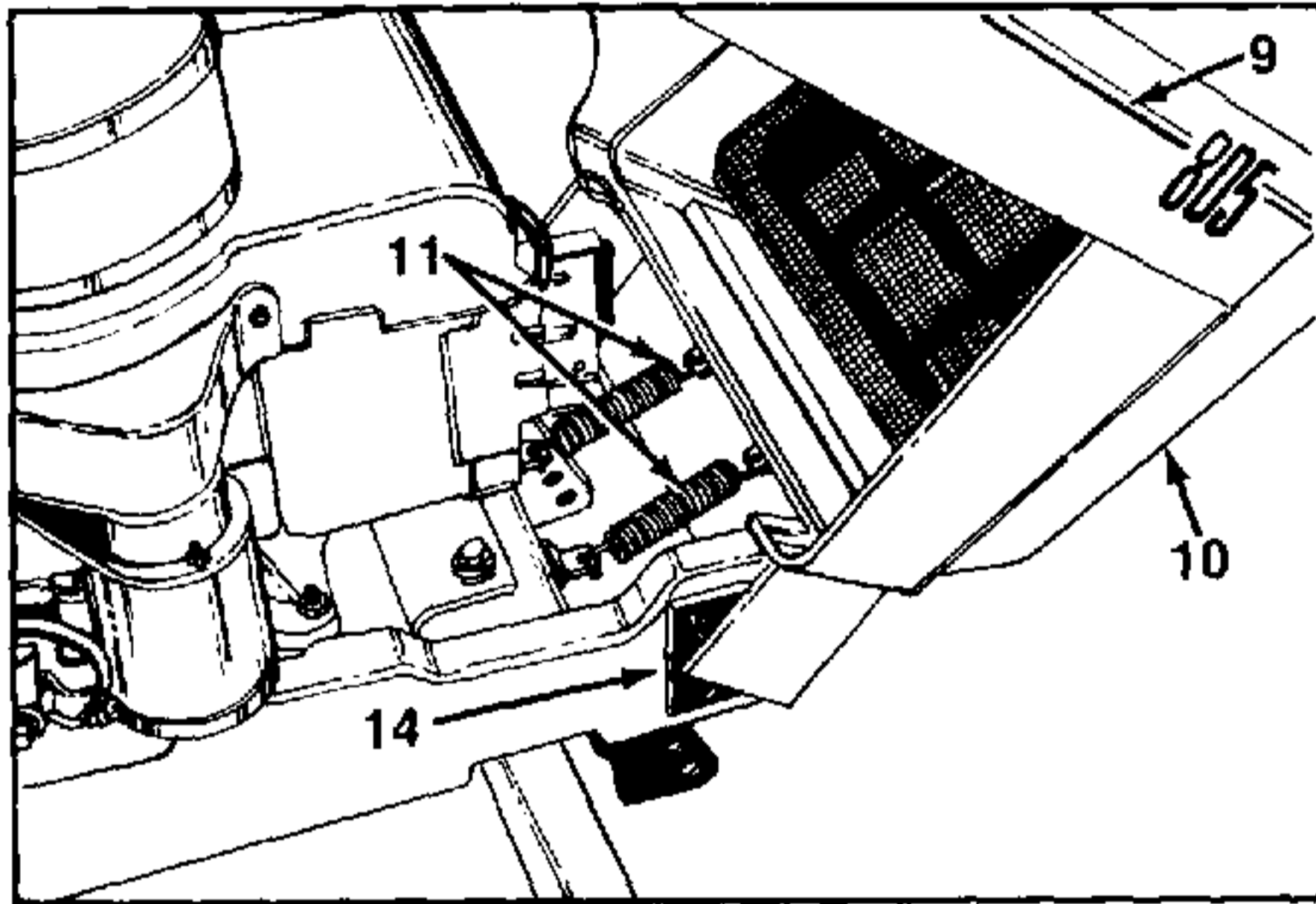

FIGURE 5.

5. Upon removal of extension spring, loosen hex bolts and Belleville washers (Ref. 12) on each side of chassis. See figure 6. Remove one set of bolts and washers from one side only. This will allow you to pull the hood and grille off of the front pivot bracket (Ref. 13 and 14). See figure 6.

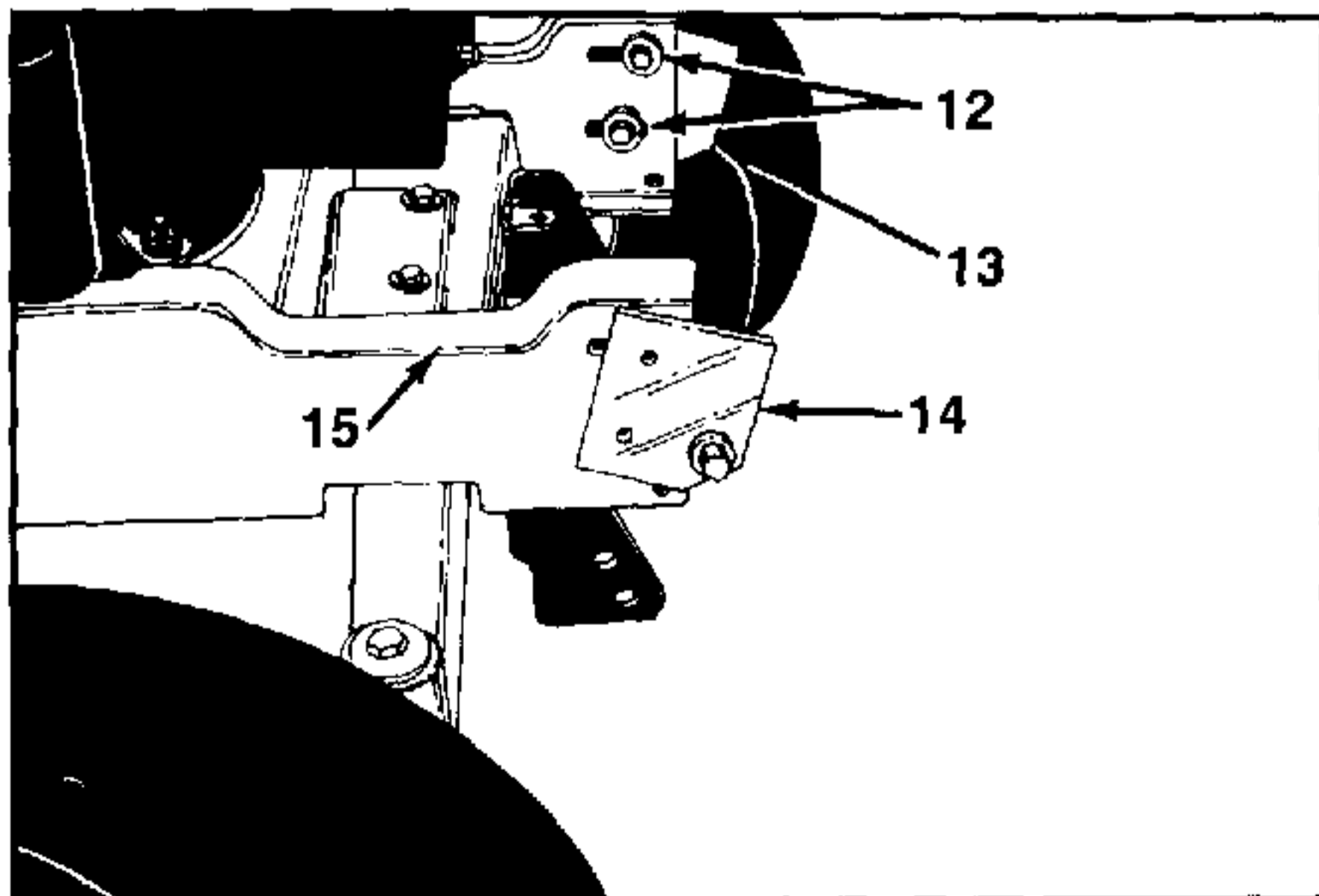

FIGURE 6.

NOTE

Be sure pivot brackets are reassembled as shown in figure 6.

- 9. Hood
- 10. Grille
- 11. Extension Springs
- 12. Hex Bolt and Bell.-Washers
- 13. Right Hand Pivot Bracket
- 14. Left Hand Pivot Bracket
- 15. Chassis

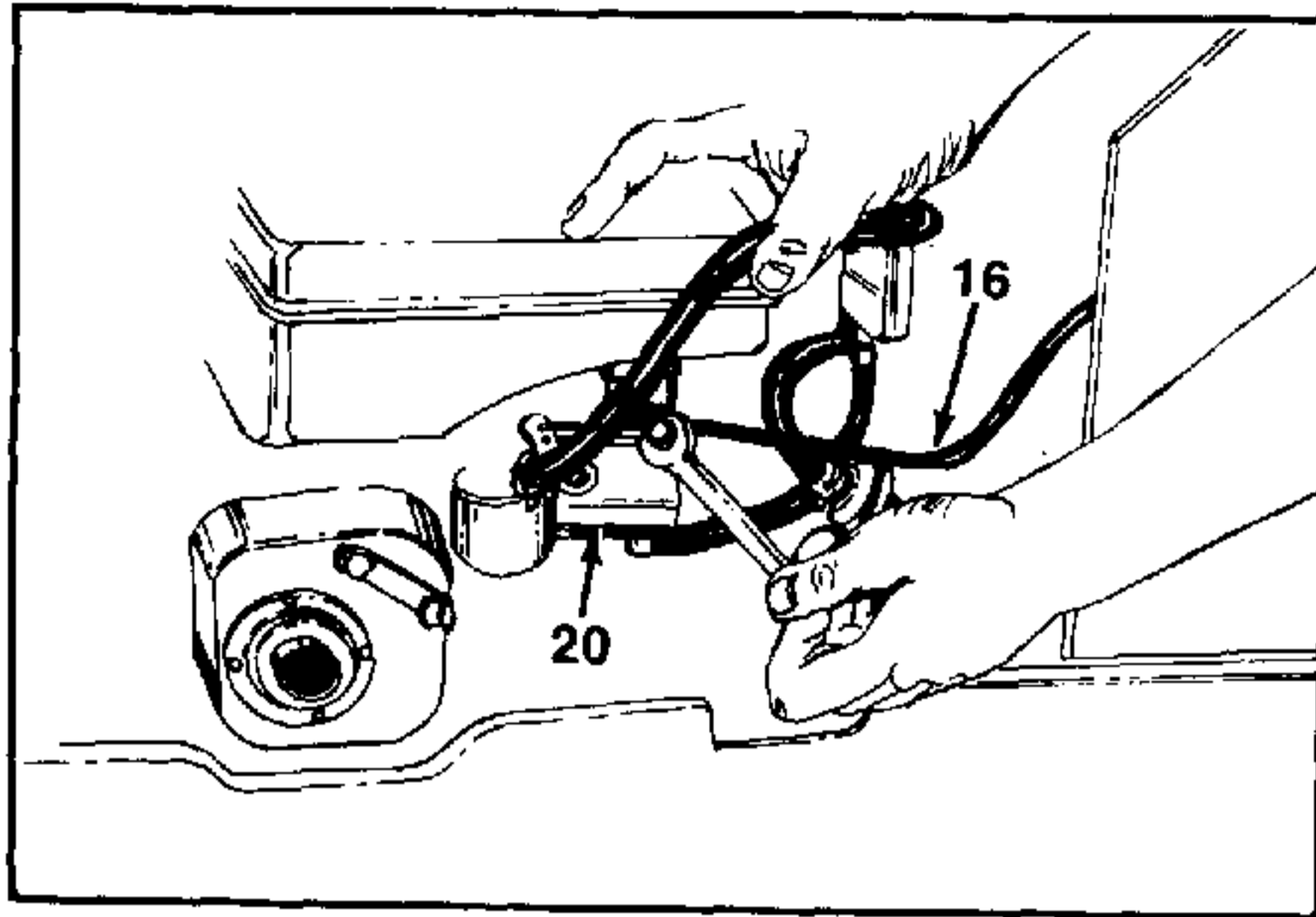

FIGURE 7.

6. Disconnect the choke cable (Ref. 16) at the carburetor (Ref. 20). See figure 7.

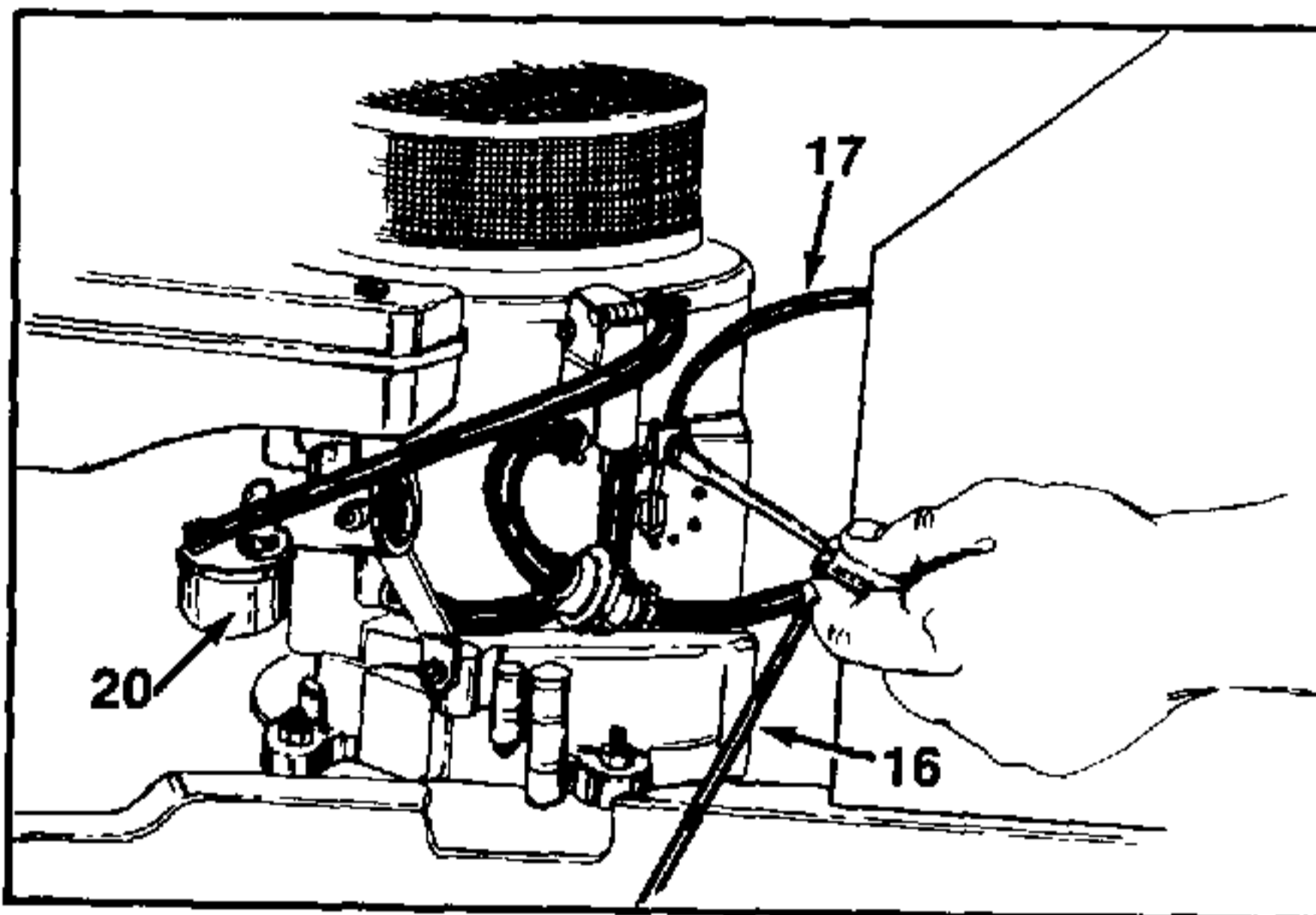

FIGURE 8.

7. Disconnect the throttle control cable (Ref. 17) from the left hand side of engine. See figure 8.

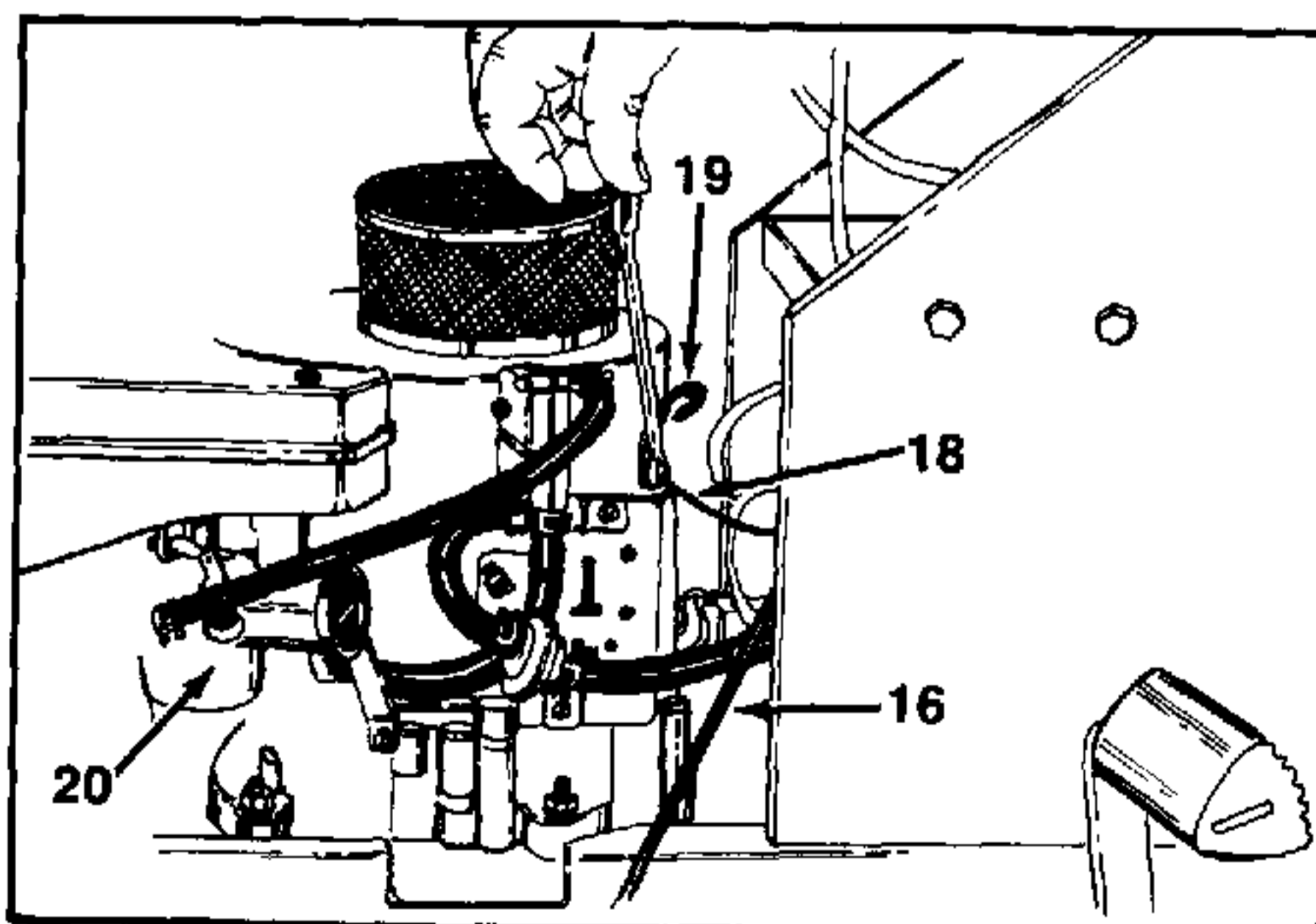

FIGURE 9.

8. Disconnect the ground wire (Ref. 18) from the back of engine and remove the cable clamp (Ref. 19) at the same time. See figure 9.

- | |
|---|
| <ul style="list-style-type: none"> 16. Choke Cable 17. Throttle Cable 18. Ground Wire at Engine 19. Cable Clamp 20. Carburetor |
|---|

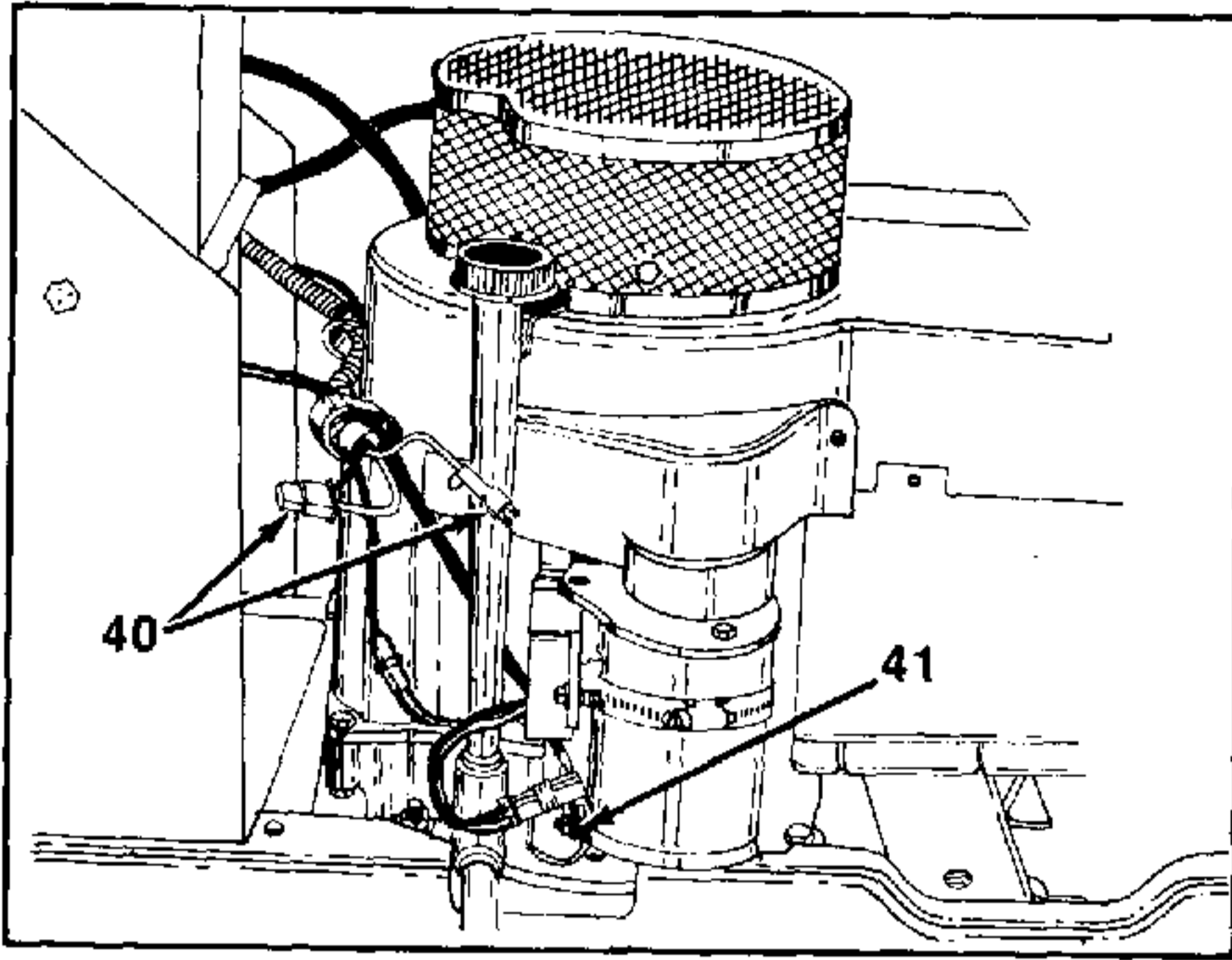

FIGURE 10.

9. Disconnect the main harness connection (Ref. 40) and starter cable (Ref. 41) at engine. See figure 10.

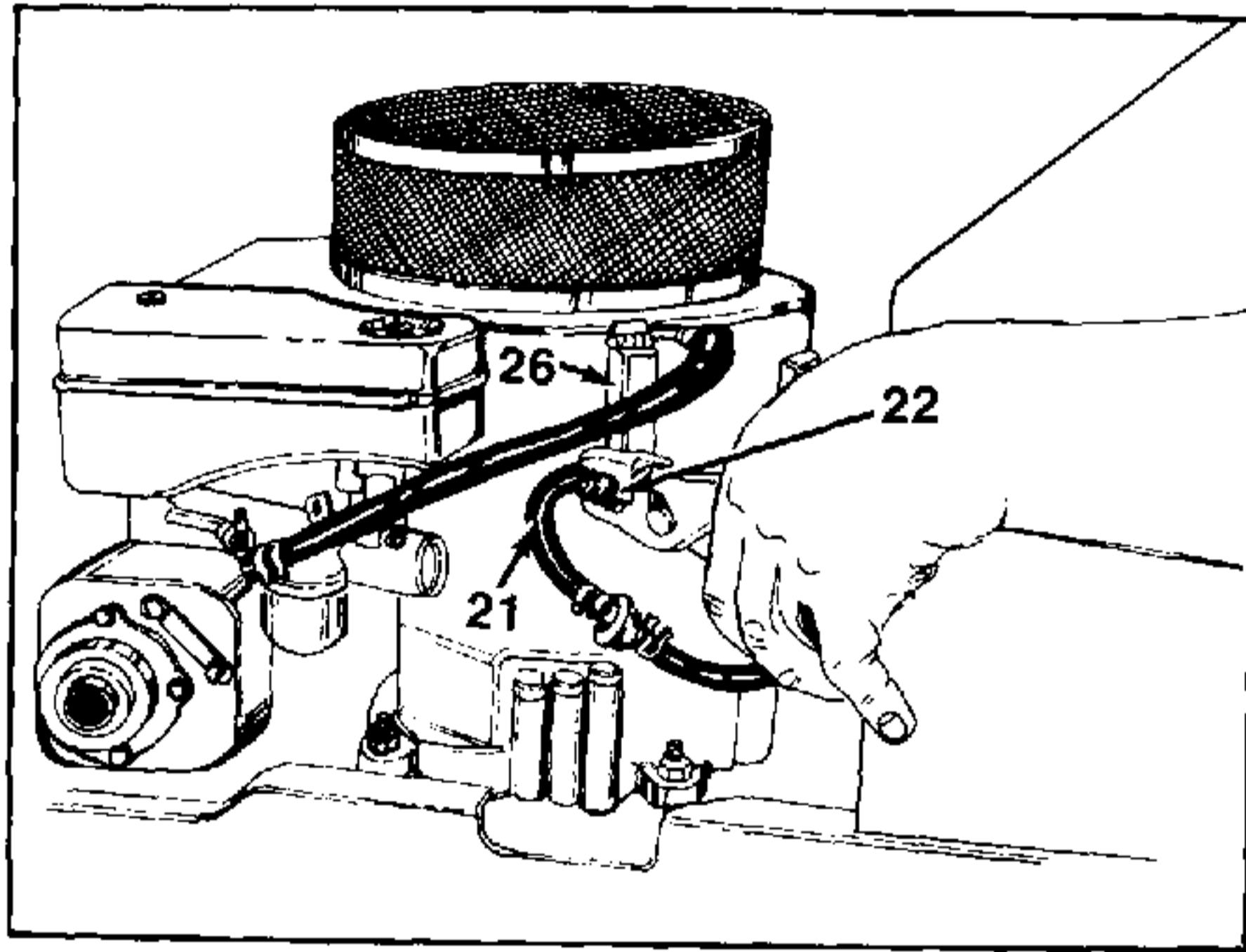

FIGURE 11.

10. Disconnect the fuel line (Ref. 21) and fuel line clamp (Ref. 22) from the fuel pump (Ref. 26). See figure 11.

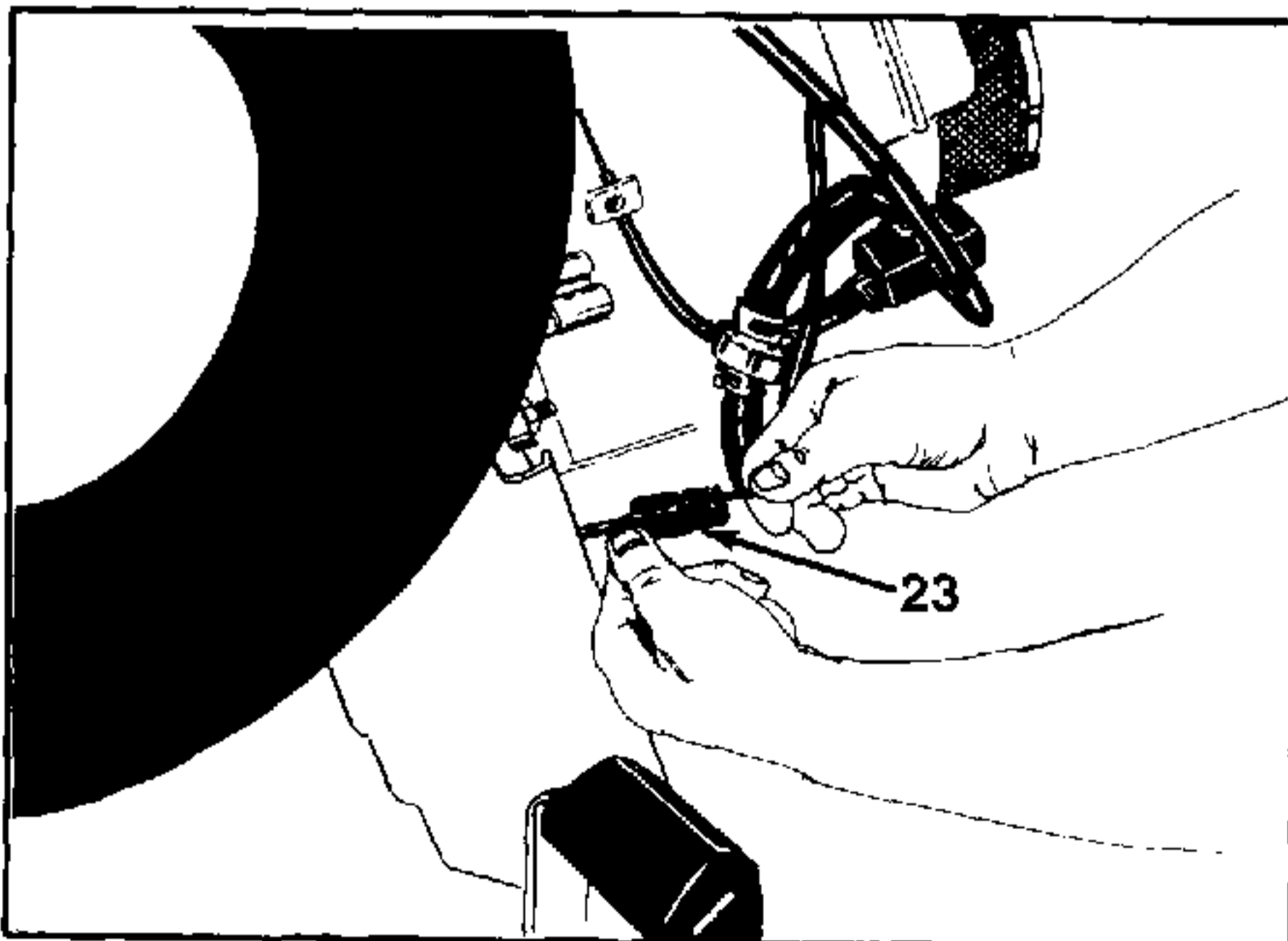

FIGURE 12.

11. Disconnect the module lead (Ref. 23) for the electric clutch. See figure 12.

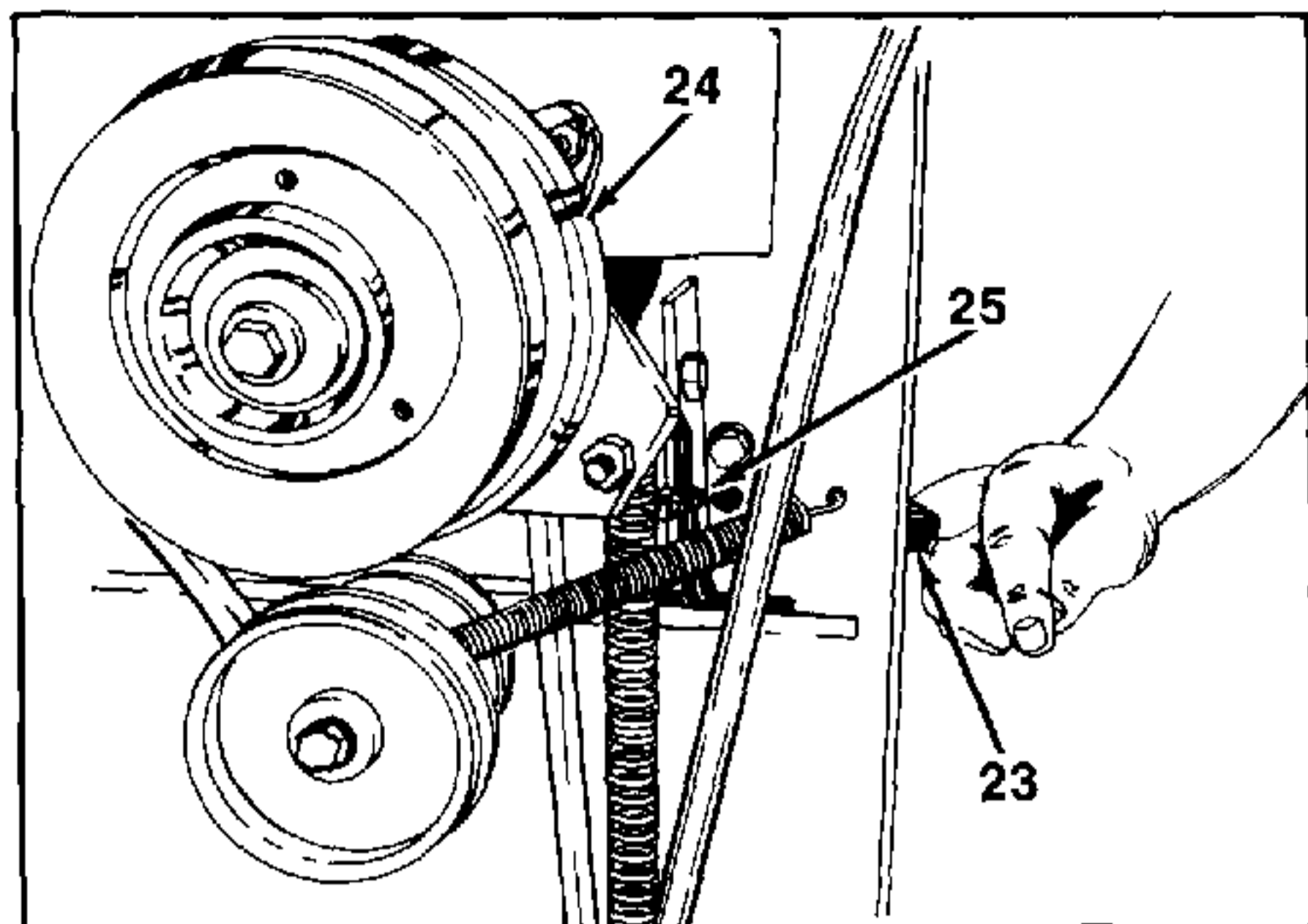

FIGURE 13

12 Cut the cable tie (Ref 25) holding the electric wire to the electric clutch (Ref 24) See figure 13

- | | |
|----|---------------------------------|
| 21 | Fuel Line |
| 22 | Fuel Line Clamp |
| 23 | Module Lead for Electric Clutch |
| 24 | Electric Clutch |
| 25 | Cable Tie |
| 26 | Fuel Pump |
| 40 | Main Harness Connection |
| 41 | Starter Cable |

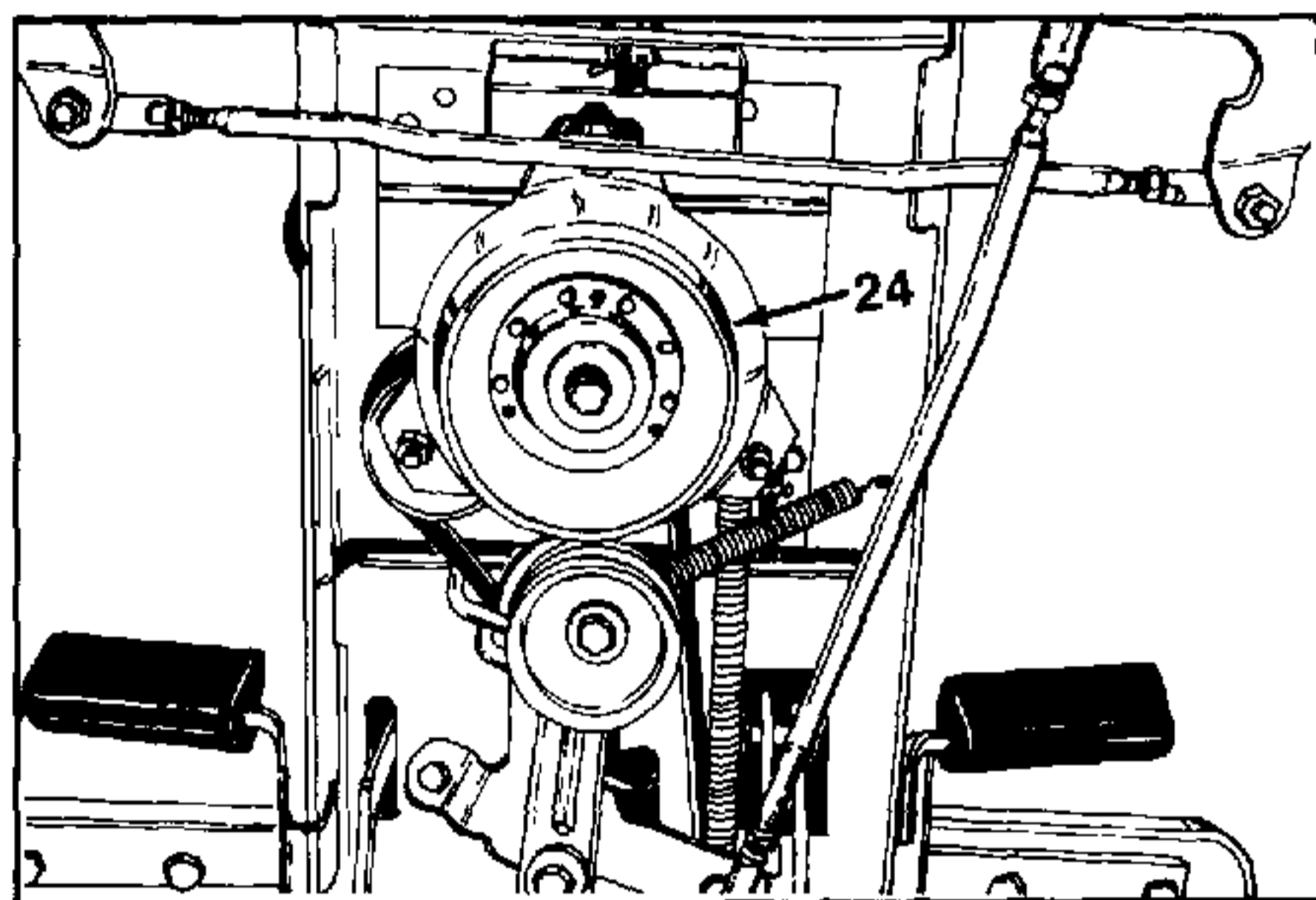

FIGURE 14

13 Remove the electric clutch (Ref 24) by removing hex bolt (Ref 27) and Belleville washer (Ref 28) See figures 14 and 15

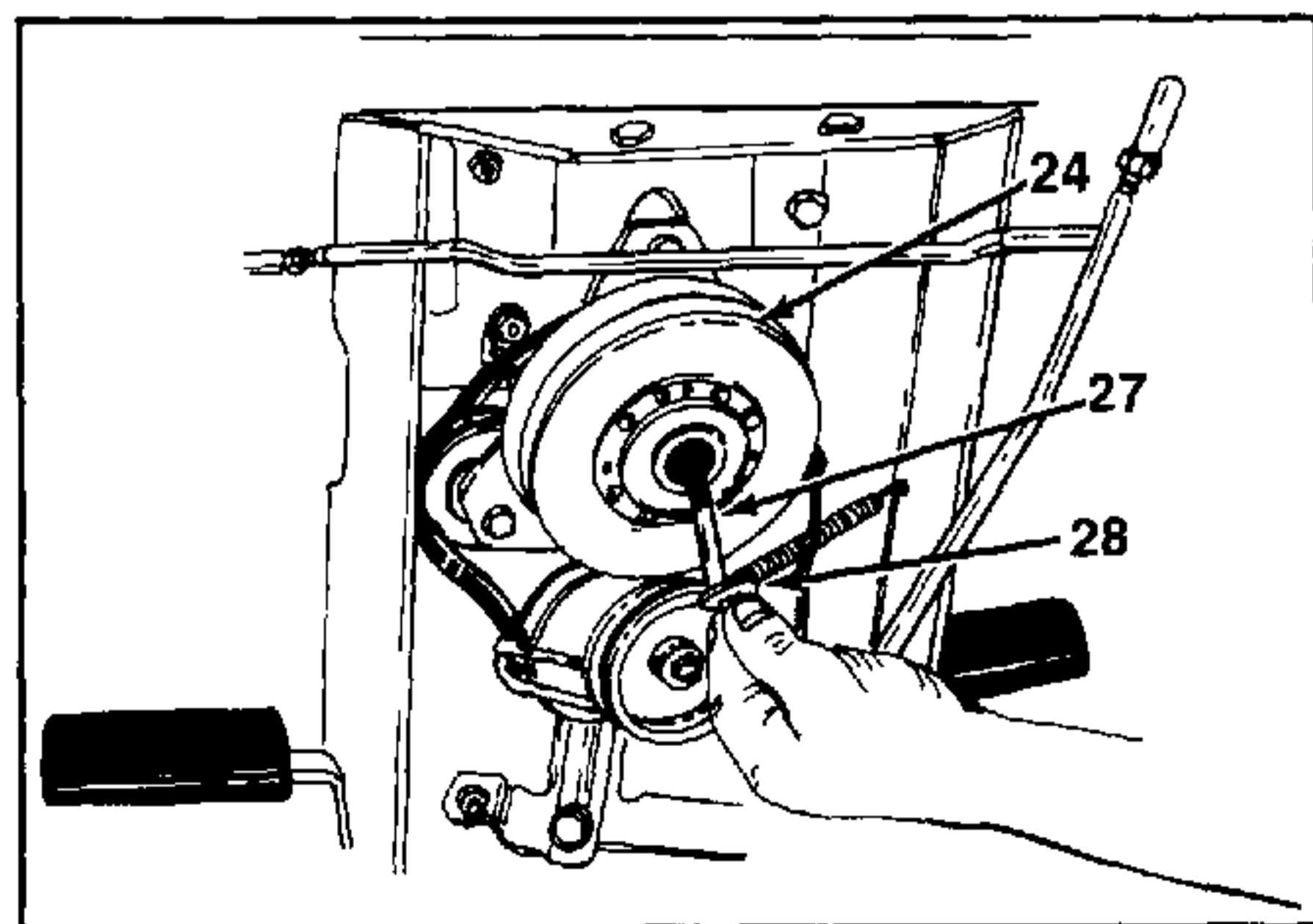
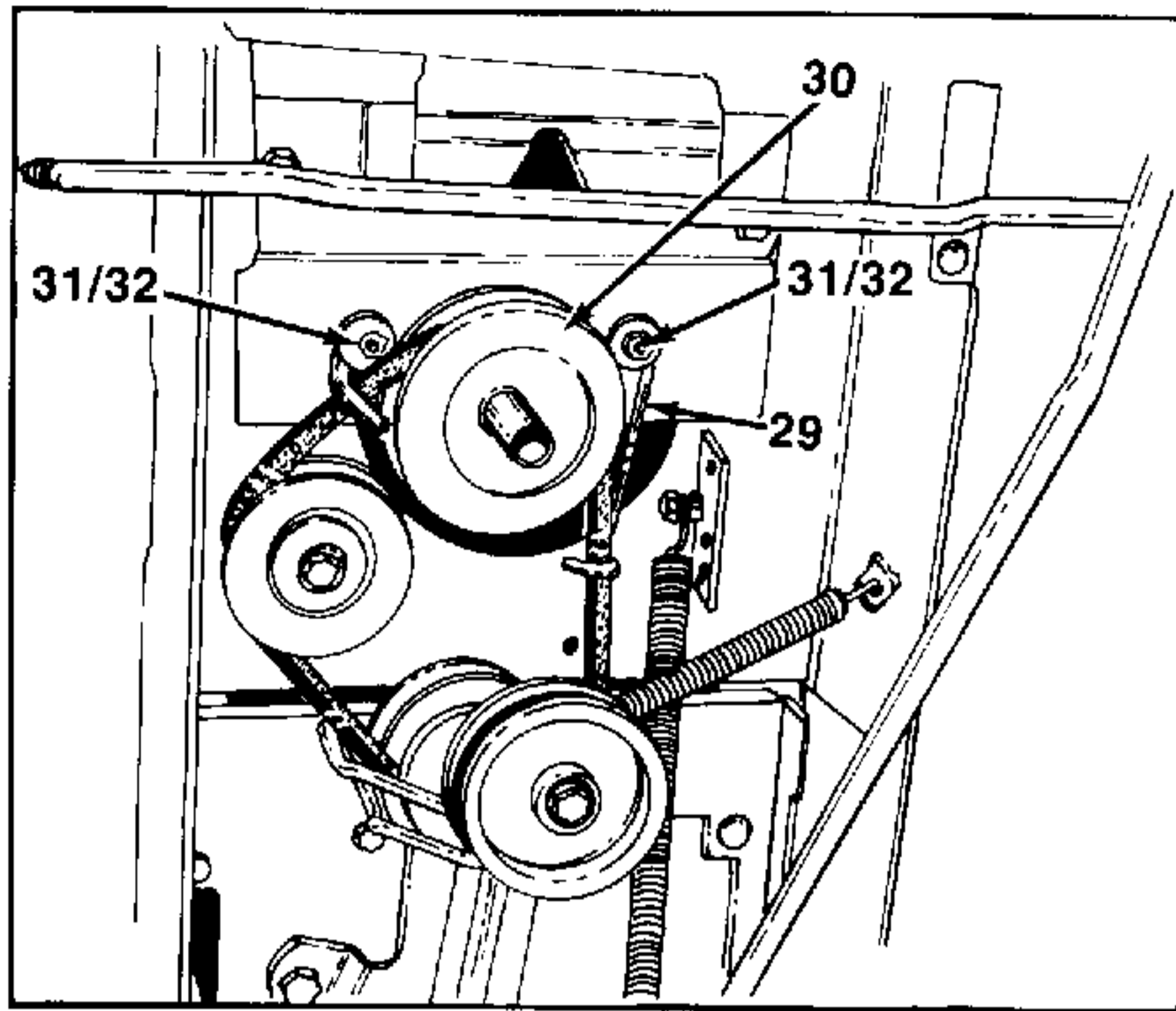

FIGURE 15



14. Remove the engine pulley belt guard (Ref. 29) by removing two hex nuts (Ref. 31) and flat washers (Ref. 32). See figure 16.

- | | |
|-----|--------------------------|
| 24. | Electric Clutch |
| 27. | Hex Bolt |
| 28. | Belleville Washer |
| 29. | Engine Pulley Belt Guard |
| 30. | Engine Pulley |
| 31. | Hex Nuts |
| 32. | Flat Washers |

FIGURE 16.

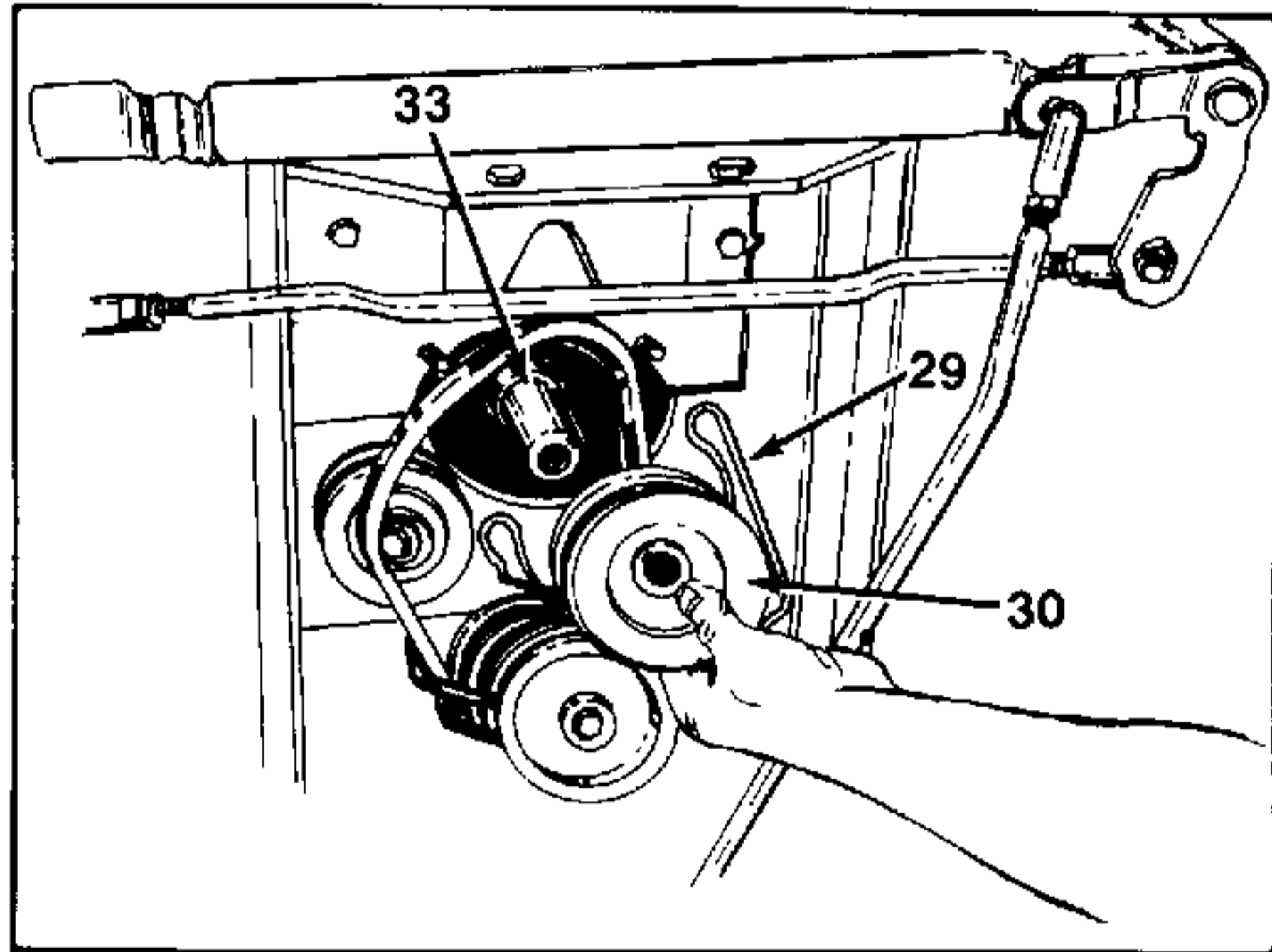

15. Remove the engine pulley (Ref. 30) and engine pulley belt guard (Ref. 29). See figure 17.

FIGURE 17.

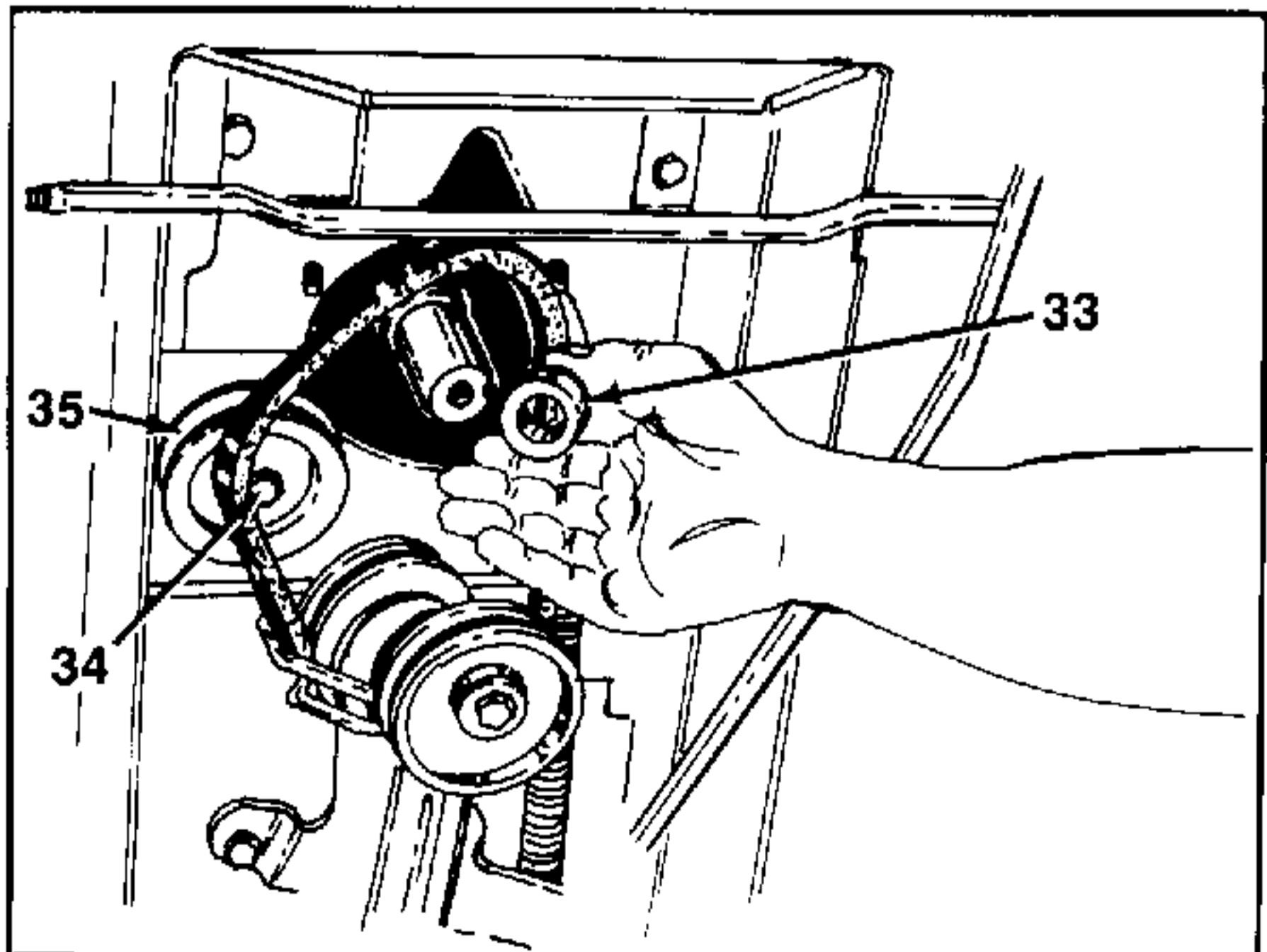

16. Remove the spacer (Ref. 33). See figures 17 and 18.

FIGURE 18.

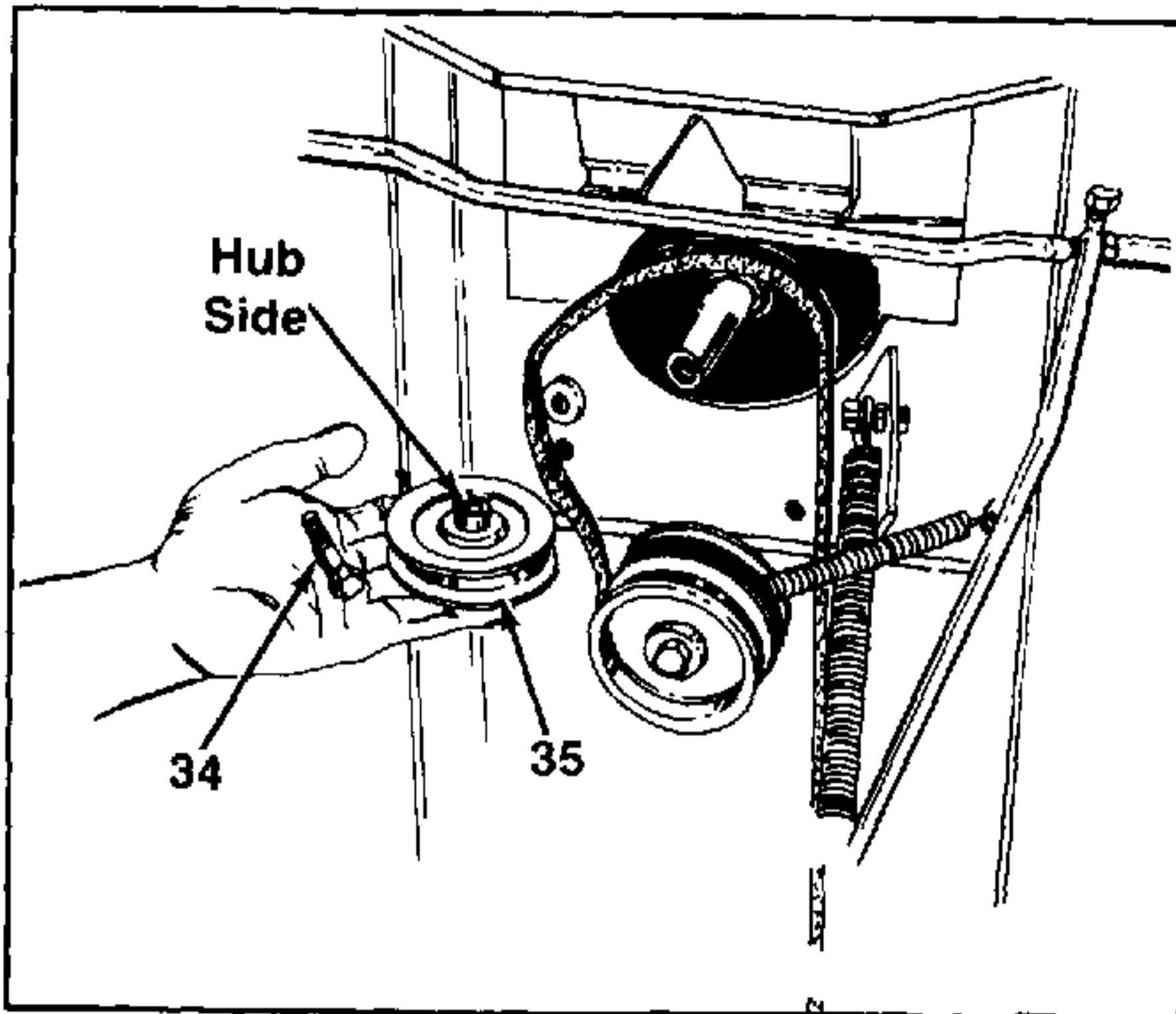

FIGURE 19.

17. Remove the idler pulley (Ref. 35) by removing hex bolt (Ref. 34) if you want to remove the belt. See figures 18 and 19.

NOTE

Upon reassembly of the idler pulley (Ref. 35) the hub side must go against the tractor frame.

- 29. Engine Pulley Belt Guard
- 30. Engine Pulley
- 33. Spacer, Crankshaft
- 34. Hex Bolt
- 35. Idler Pulley

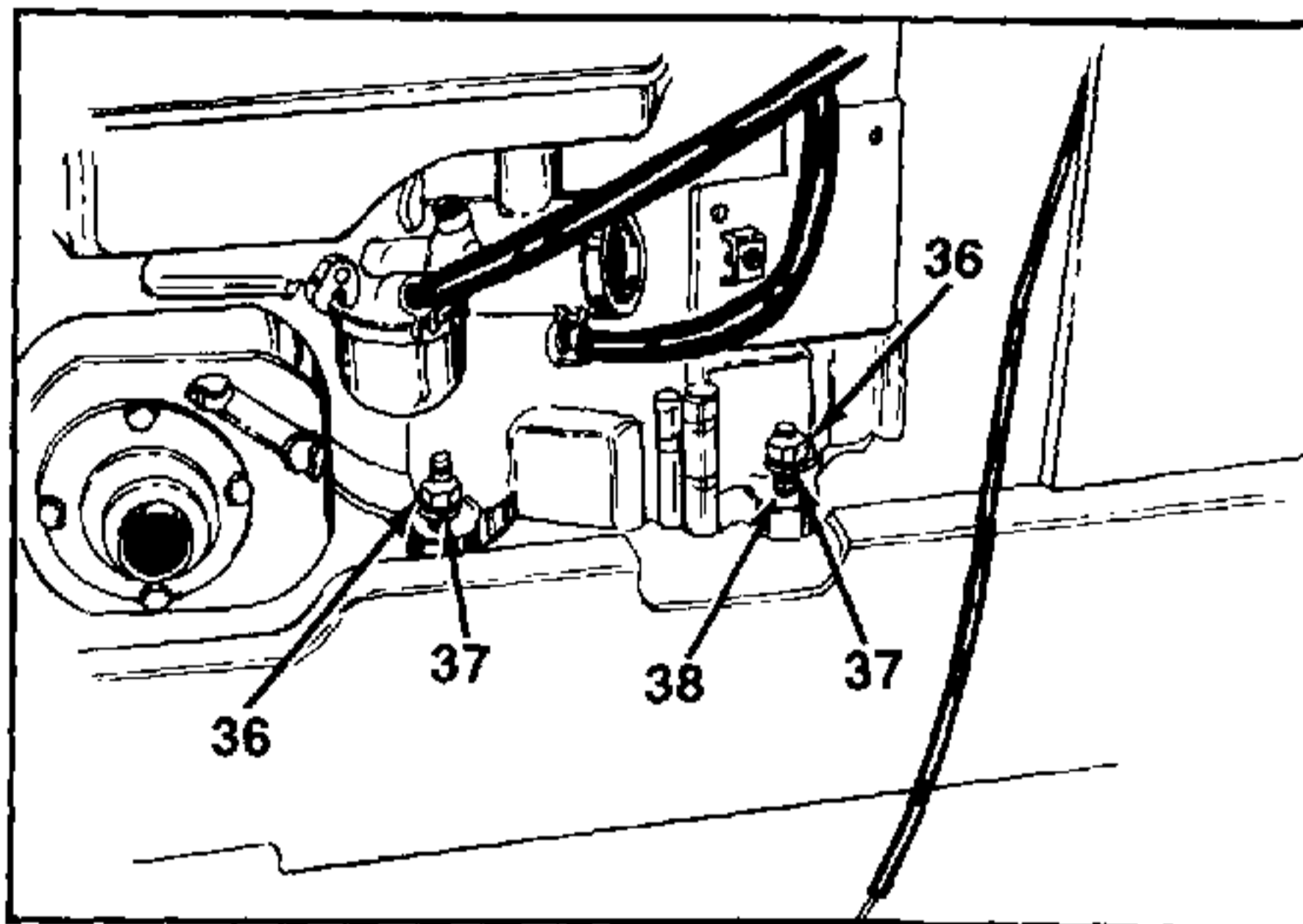

FIGURE 20.

18. Now the engine may be unbolted and removed. Remove four hex nuts (Ref. 36), lock washers (Ref. 37) and hex bolts (Ref. 39) at the engine base. See figure 20.

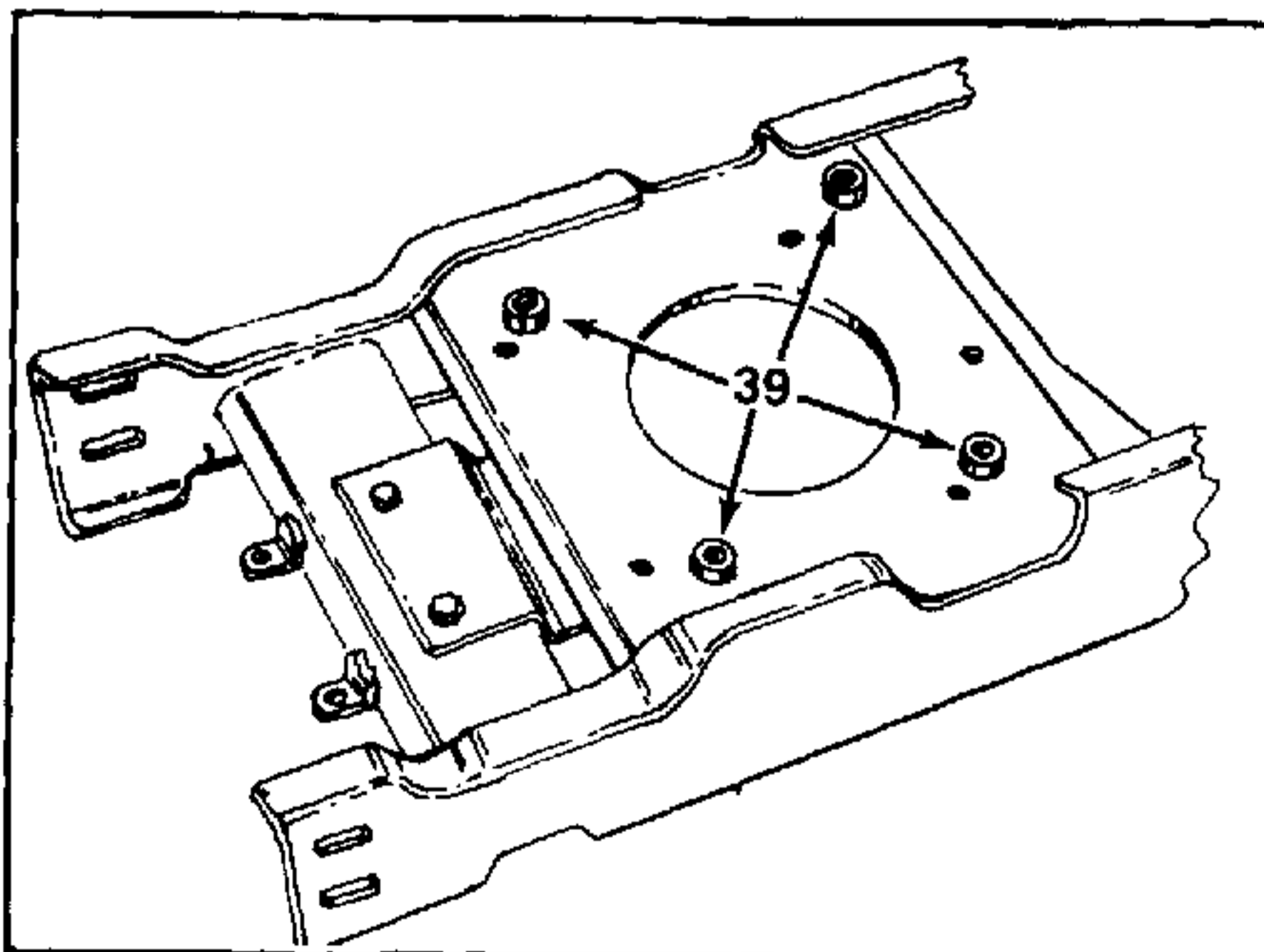

FIGURE 21.

19. Lift the engine up. NOTE: There are four engine spacers (Ref. 39) under the engine. Figure 21 shows correct holes for reassembly.

- 36. Hex Nuts
- 37. Lock Washers
- 38. Hex Bolts
- 39. Spacers, Under Engine

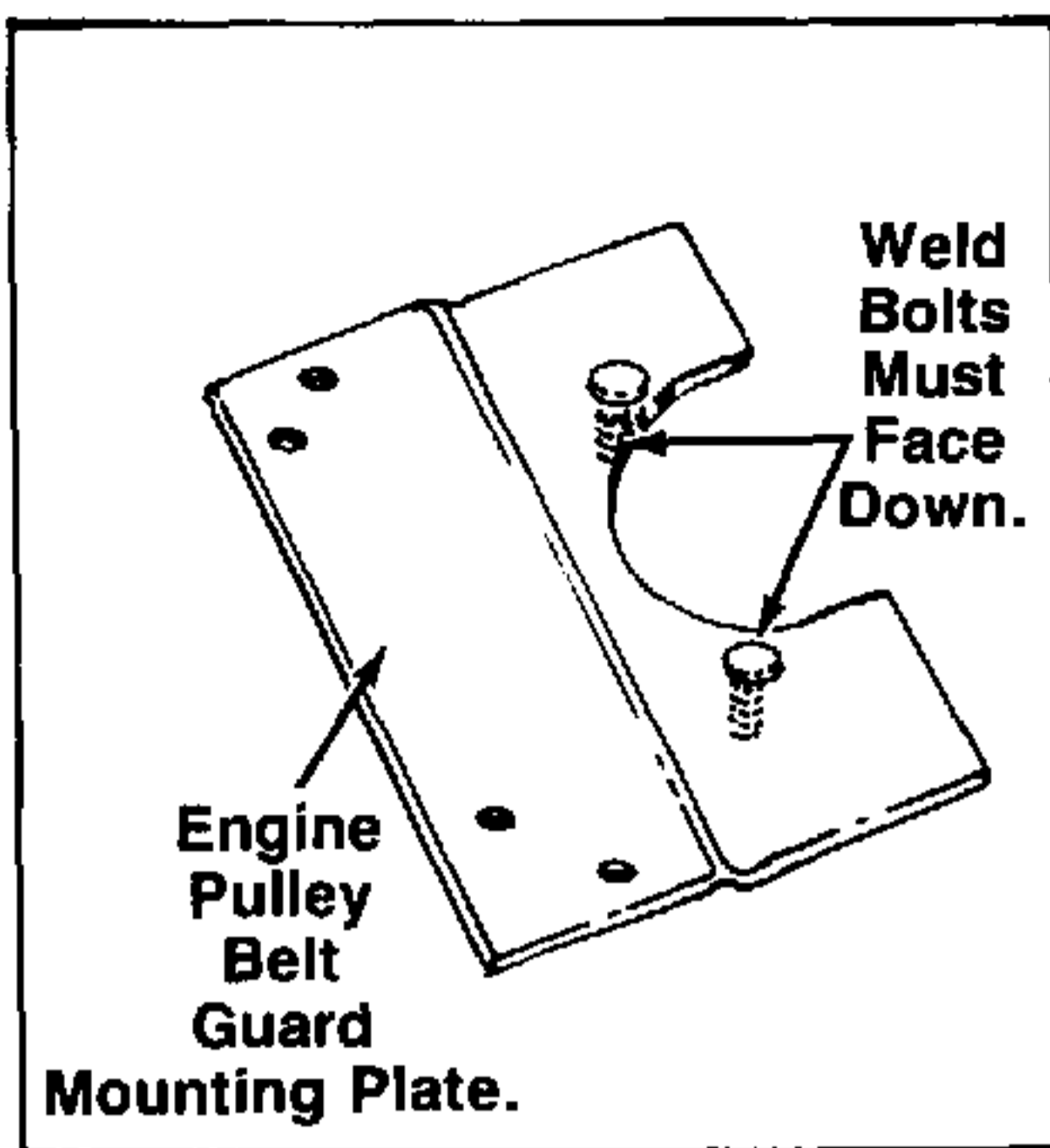

FIGURE 22.

REASSEMBLY NOTE:

When you remove the engine mounting bolts, the engine belt guard mounting plate will drop down. Upon reassembly of this plate, the weld bolts must face the ground. See figure 22.

NOTE: For specifications and overhaul procedures, refer to one of the following service manuals:

BS-270962: Briggs & Stratton Single Cylinder Engines

BS-271172: Briggs & Stratton Twin Cylinder Engines

KH-TP-2289: Kohler Twin Cylinder, Vertical Shaft Engines

Installation

1. Install engine by reversing the removal procedure.
2. Adjust the following as necessary:
 - a. Governor/Throttle Linkage
 - b. Choke Linkage
 - c. Carburetor

ELECTRICAL SYSTEM

LAWN TRACTORS

Function: Engine Cranking

Requirements to start engine

1. Operator must be in seat.
2. PTO switch must be off.
3. Transmission must be in neutral.
4. Key switch must be turned to start position.

The Current flows from the battery through a fuse and ammeter to the B terminal on the key switch. Current then passes from B terminal to the S terminal on the key switch. It then follows a red wire to the neutral indicator switch and continues via a red wire to terminal number 1 on the PTO switch and continues on via a red wire to the S terminal on the solenoid switch. This energizes the 2 main terminals on the solenoid switch which causes the starter to crank over.

Function: Engine Run

1. Keyswitch must be in the "run" position.

In the run position, current is allowed to pass from terminal B to terminal L of the keyswitch. This makes voltage produced by the alternator available to the battery and also makes battery voltage available to the PTO switch at terminal #5 as well as terminal #1 of the reverse relay and to the PTO indicator.

Function: PTO Start

Requirements to Start the PTO

1. Operator must be in the seat.
2. PTO switch must be moved from the off position to the start position.
3. Transmission lever must be in neutral or forward, but not reverse.

When the PTO switch is moved to the "start" position, battery voltage at terminal #5 of the PTO switch can flow to terminals #3 and #4. Current to terminal #3 flows to the PTO clutch through a black wire. Current is also available to the seat switch, but with an operator in the seat the switch is open and current flow is interrupted.

Battery voltage available to terminal #4 of the PTO switch can flow through a brown wire to the reverse switch (operated by the transmission shift lever). With the transmission in neutral or forward, current passes through the switch through another brown wire to the reverse relay. Relay now becomes energized and contact is made between the red and black wires within the relay. Once the PTO is started the PTO switch can be released and the spring within the switch will move the switch to the "run" position.

Function: PTO Run

Requirements to Run PTO

1. Transmission must remain in neutral or forward.
2. Operator must remain in seat.
3. PTO switch must remain in run position.

Once the PTO switch moves to the run position, current supply to the PTO clutch coil is supplied by the brown wire to the reverse relay. This energizes the coil inside relay which causes points to close between the red wire and the black wire of the reverse relay. If the tractor transmission shift lever is moved to reverse while the PTO is in the "run" position, the reverse switch will open, disrupting the current flow to the reverse relay coil. As a result, the points will open between the red and black wires, disrupting the flow of current to the PTO field coil and the PTO will disengage.

If the operator leaves the tractor seat with the PTO switch in the "run" position, the engine will stall. This occurs because as the operator's weight is lifted from the seat, the seat switch closes, providing current flow from the black lead, PTO wire, through a "seat relay."

As current passes through the relay from the black wire to the green wire the coil becomes energized and closes the contacts between the yellow wire and the green wire. The closing of these points grounds the magneto through the relay and the engine kills.

PTO Switch Off-1 & 2 On-3 & 4 Start-3&4&5	Key Switch Off-M & G Run-B & L Start-B&S
C Reverse Indicator N.C.—Relay Drops Out (Light On) N.O.—In Reverse	PTO Indicator N.C.—In Reverse N.O.—Light On
Blue Headlight Lead (725-3101)	Green
Indicator Light Lead (725-3115)	
R G BR Front View W BK Indicator Lead Female Block Male Terminal	BR G R Front View W Primary Harness (725-3105) Male Block Female Terminal
Battery Tray Harness (725-3112) R Y G R Front View A BK BK Battery Tray Harness Male Block Female Terminal	R G Y R Front View BK R BK Primary Harness Female Block Male Terminal
16 HP Only 725-3113 Alternator Lead 725-3114 Magneto Lead Alternator@ Engine	

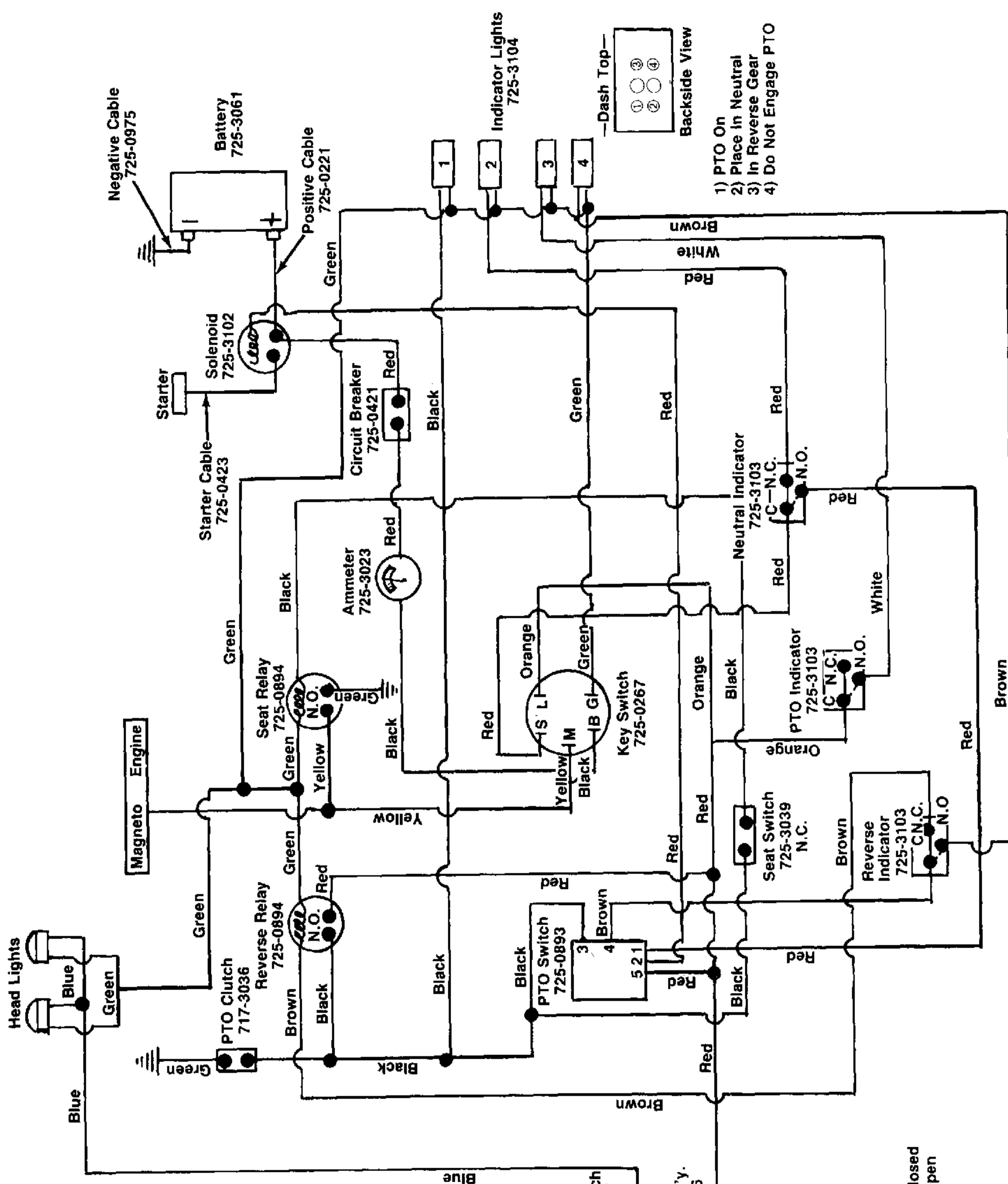

- 1) PTO On
- 2) Place in Neutral
- 3) In Reverse Gear
- 4) Do Not Engage PTO

N.C. = Normally Closed
N.O. = Normally Open

L.T. Serial Number 108,000 and Above
Serial Number 114,000 and Above

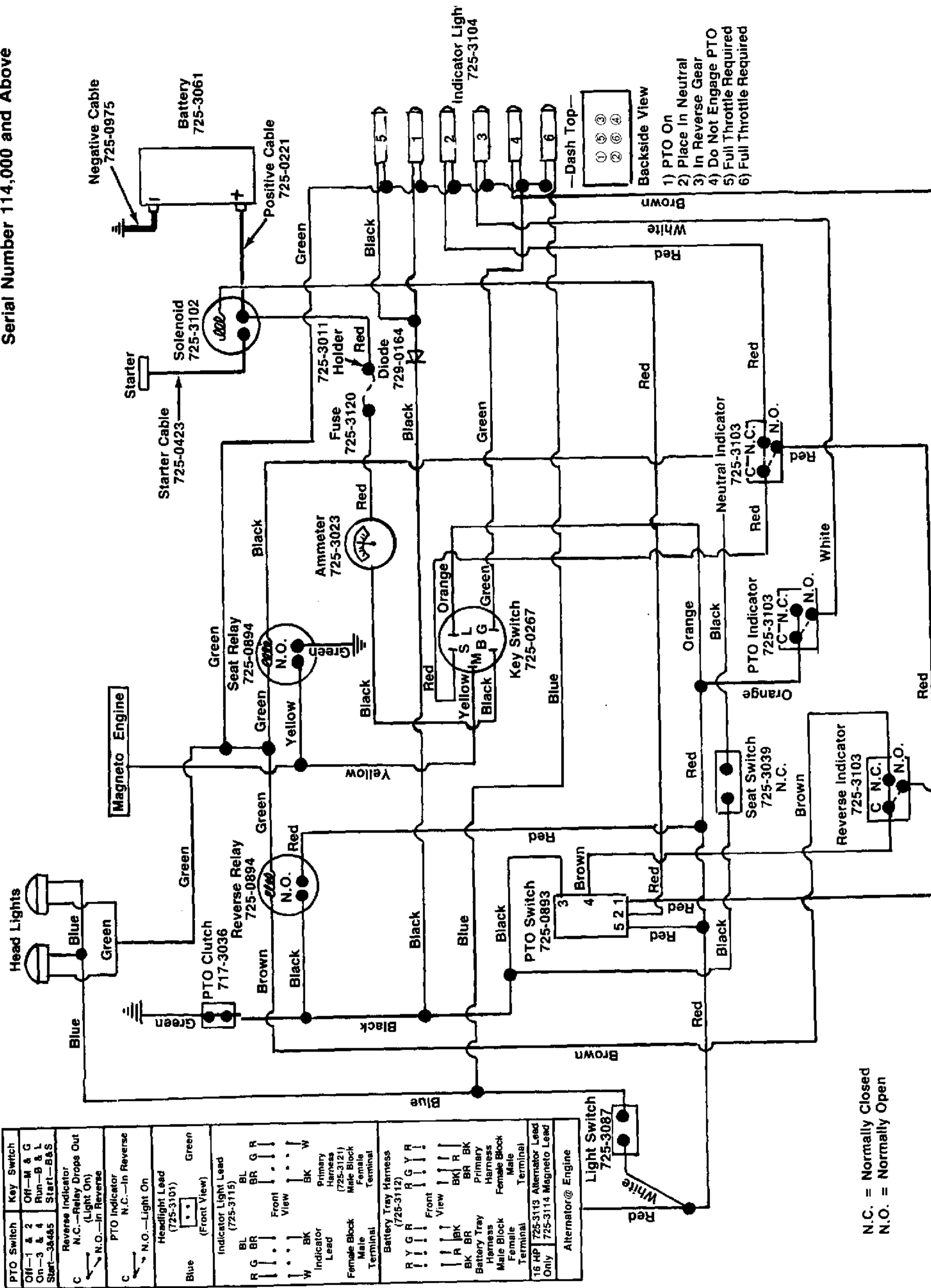

- Backside View
- 1) PTO On
 - 2) Place in Neutral
 - 3) In Reverse Gear
 - 4) Do Not Engage PTO
 - 5) Full Throttle Required
 - 6) Full Throttle Required



L.T. Serial Number 147,088 and Above
 1988 = 1015 and 1020
 1989 = 1315 and 1320

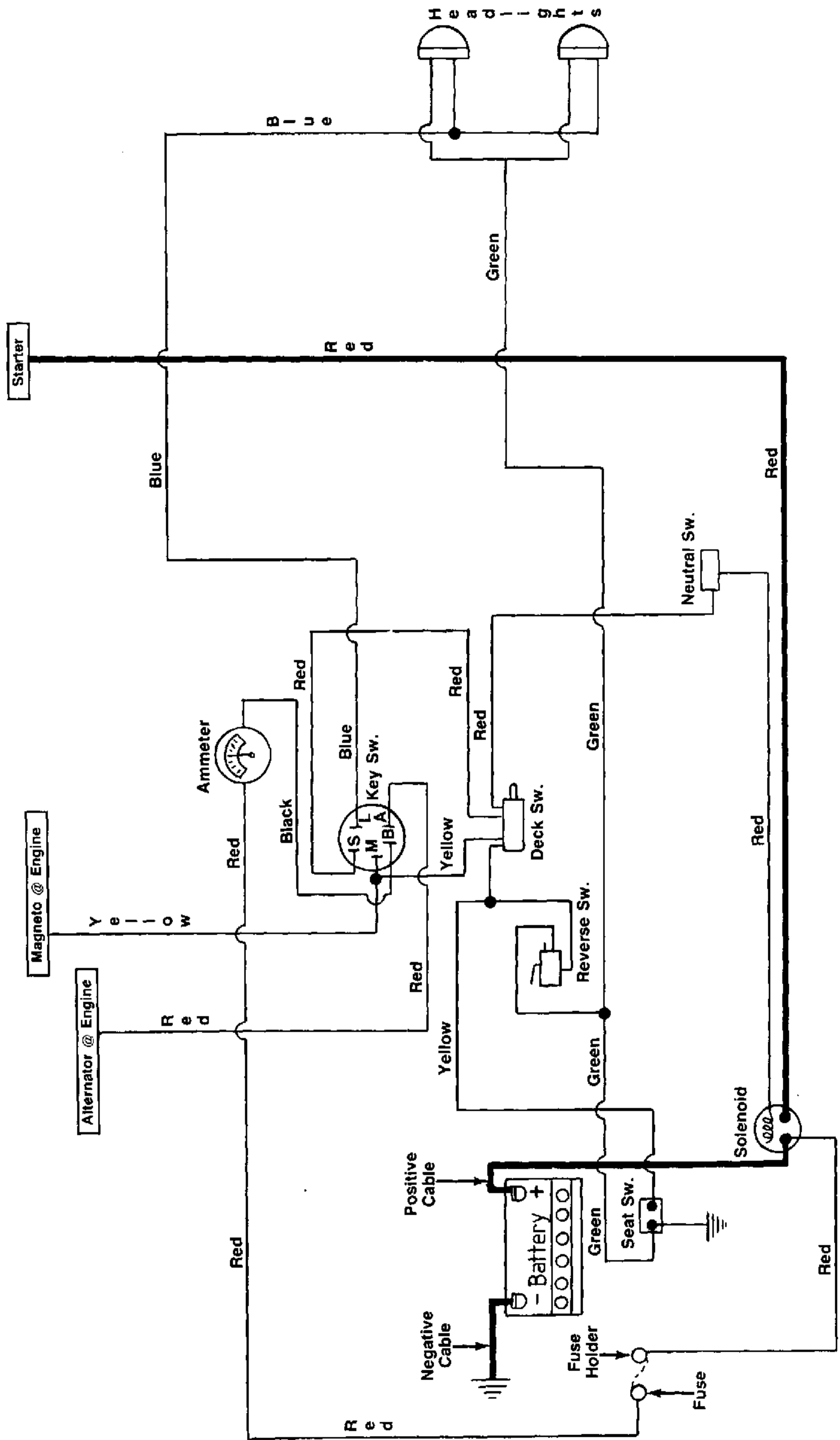

L.T. Serial Number 147,088 and Above
 1989 = 1415, 1420, 1715 & 1720

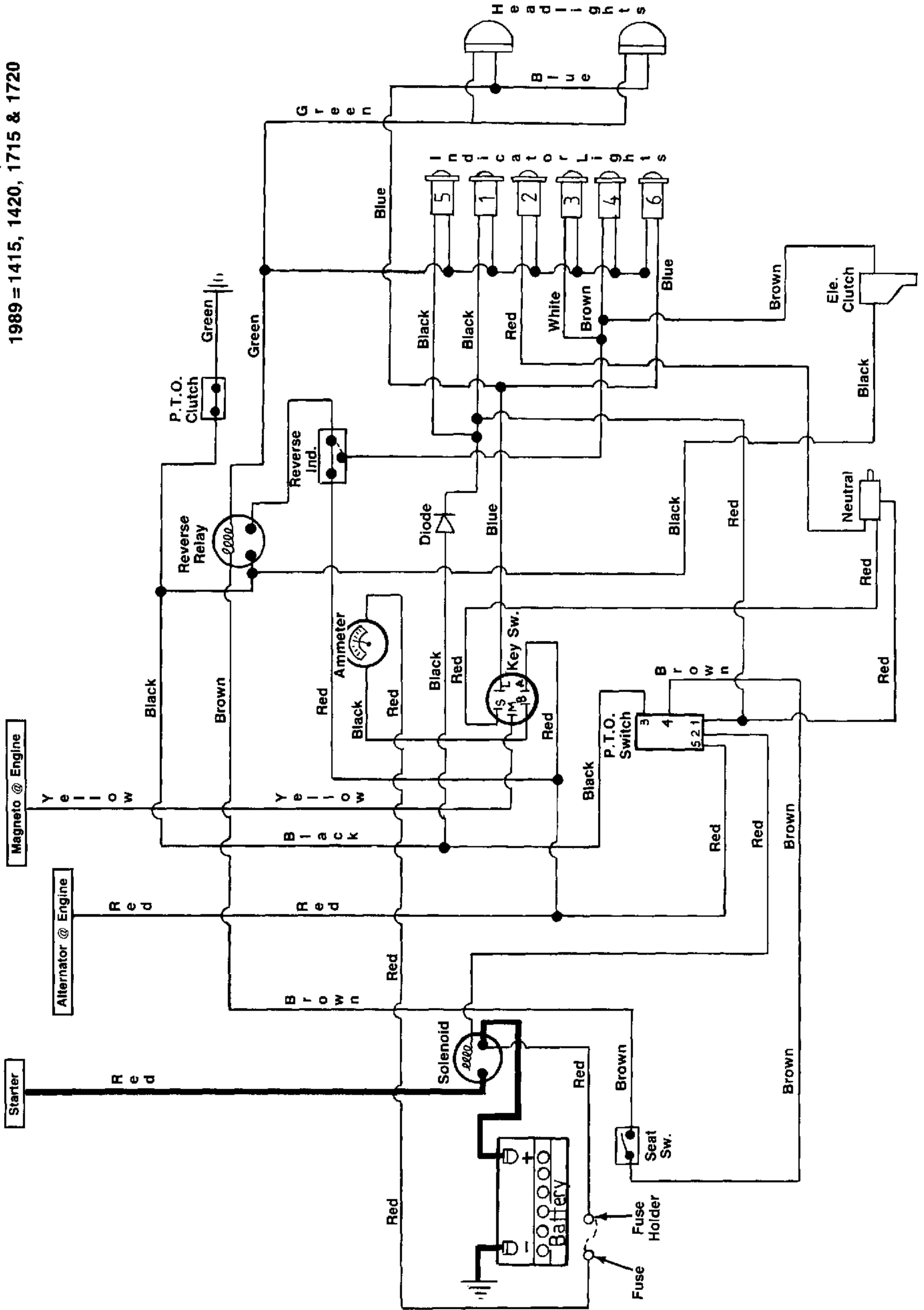

ELECTRICAL SYSTEM
L.T. Serial Number 170,601 and Above
1990 = 1405, 1420, & 1720

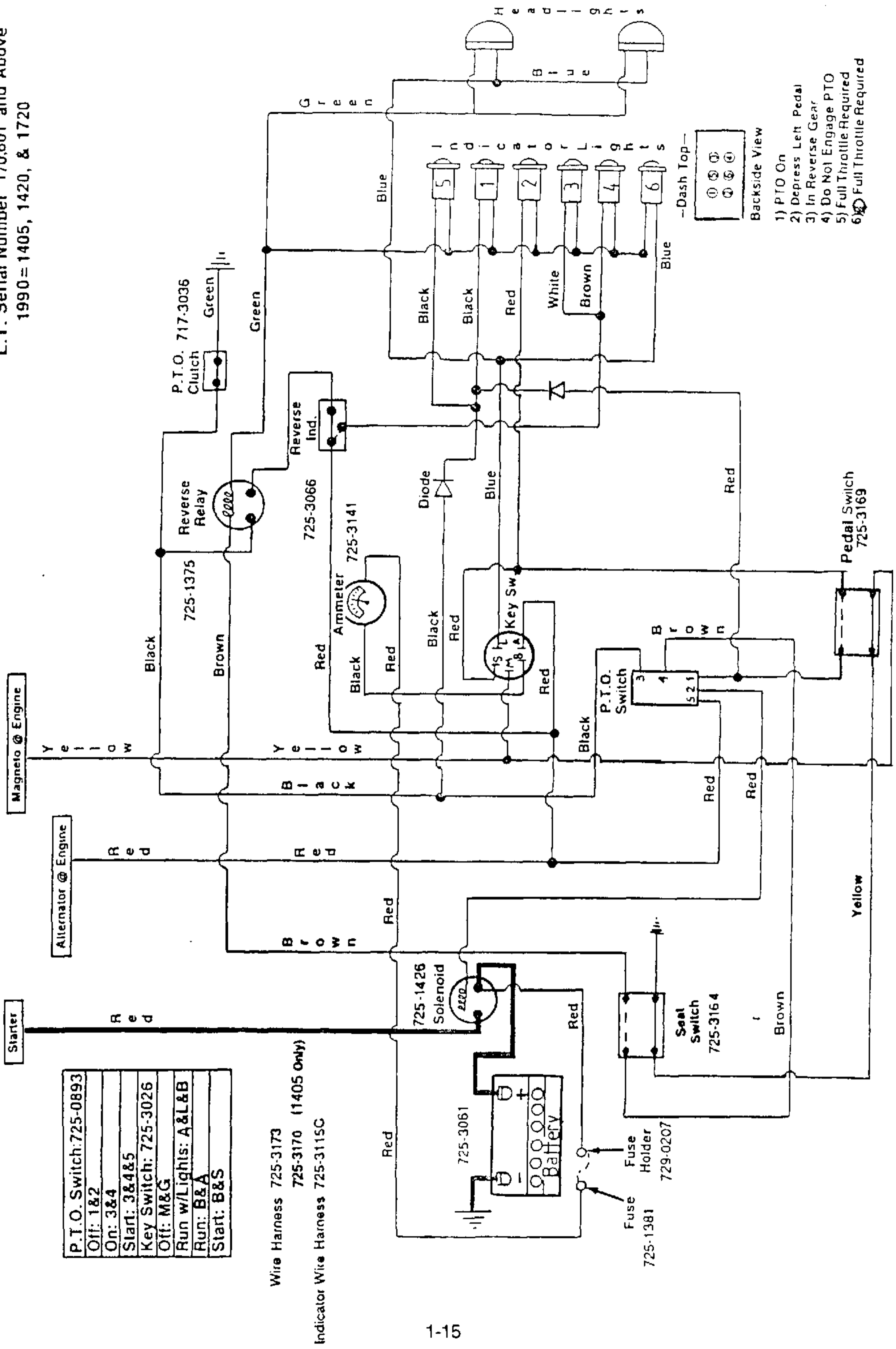

P.T.O. Switch: 725-0893
Off: 1&2
On: 3&4
Start: 3&4&5
Key Switch: 725-3026
Off: M&G
Run w/Lights: A&L&B
Run: B&A
Start: B&S

Wire Harness 725-3173
 725-3170 (1405 Only)
 Indicator Wire Harness 725-3115C

ENGINE REMOVAL

MODEL 1415, 1420, 1715 AND 1720

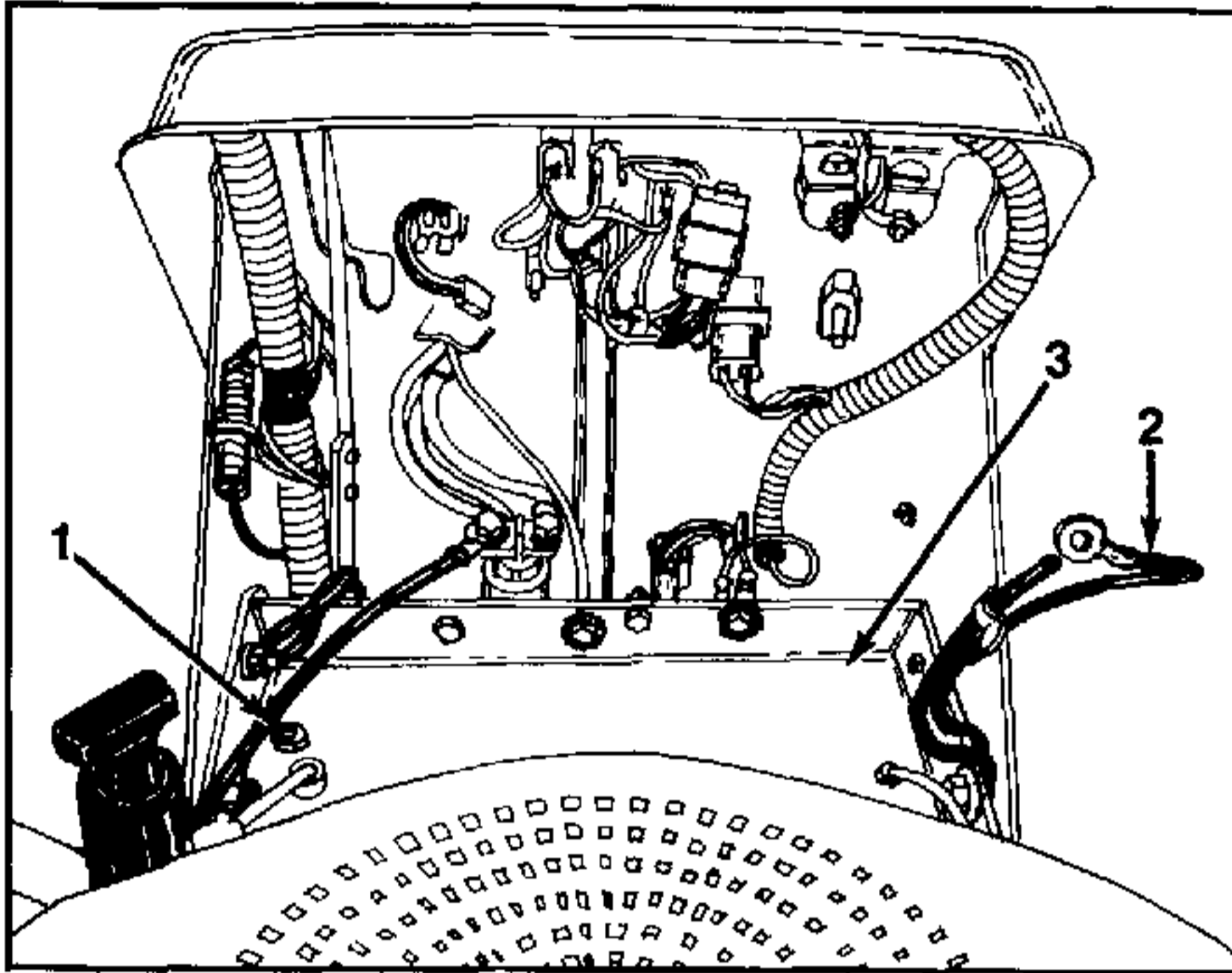

FIGURE 1.

1. Remove the battery cover, wing nuts and battery hold down rods.
2. Disconnect the battery cable's **negative cable first**, from battery post.
3. Lift out the battery from the battery tray. See figure 1.

NOTE

Battery removal on 1989 units refer to page 1-18 in this manual.

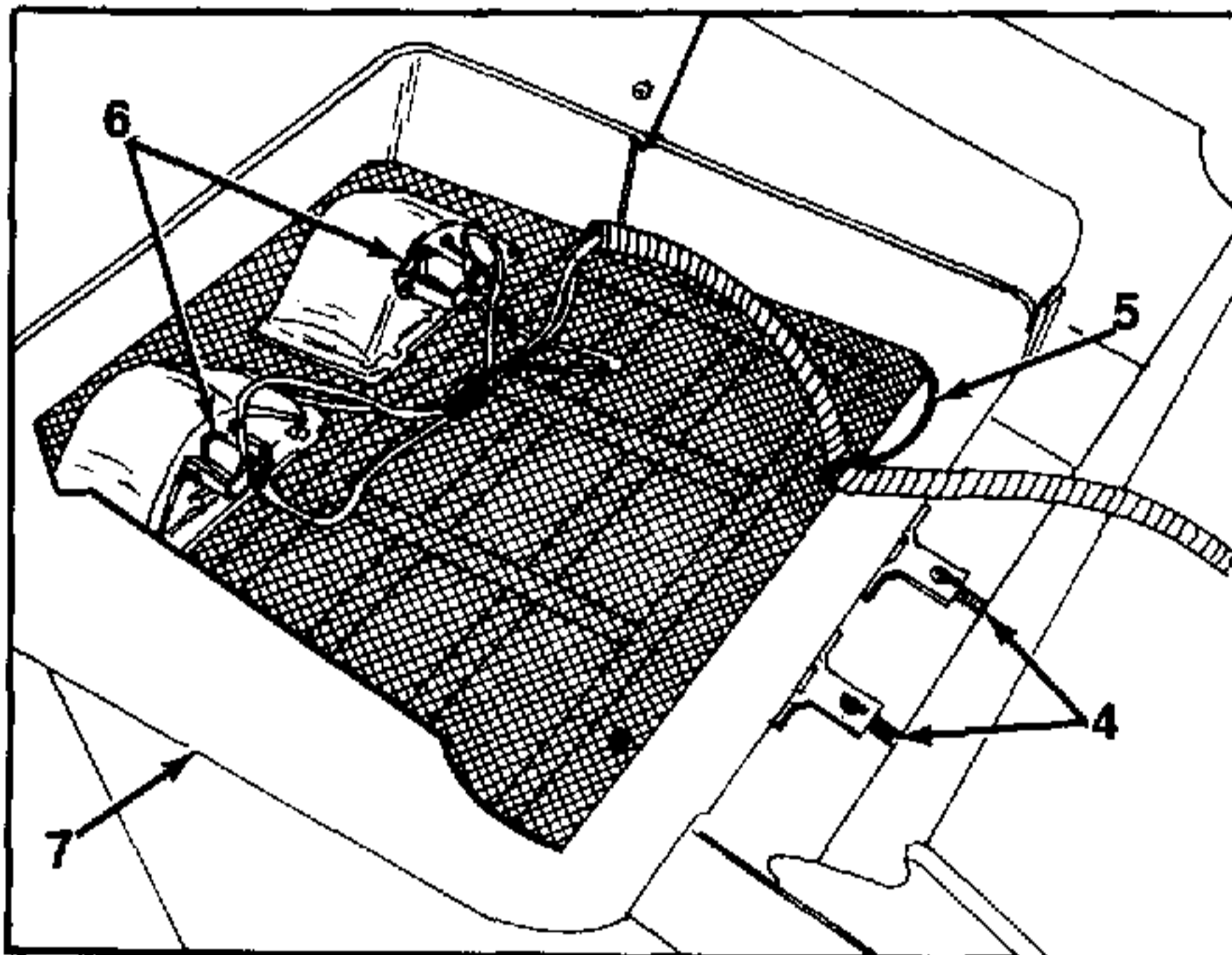

FIGURE 2.

4. Remove the hood and grille by removing the two extension springs from the grille and chassis. See figure 2.
5. Unplug the headlight terminals and cut the cable tie, holding the headlight wire harness to grille. See figure 2.

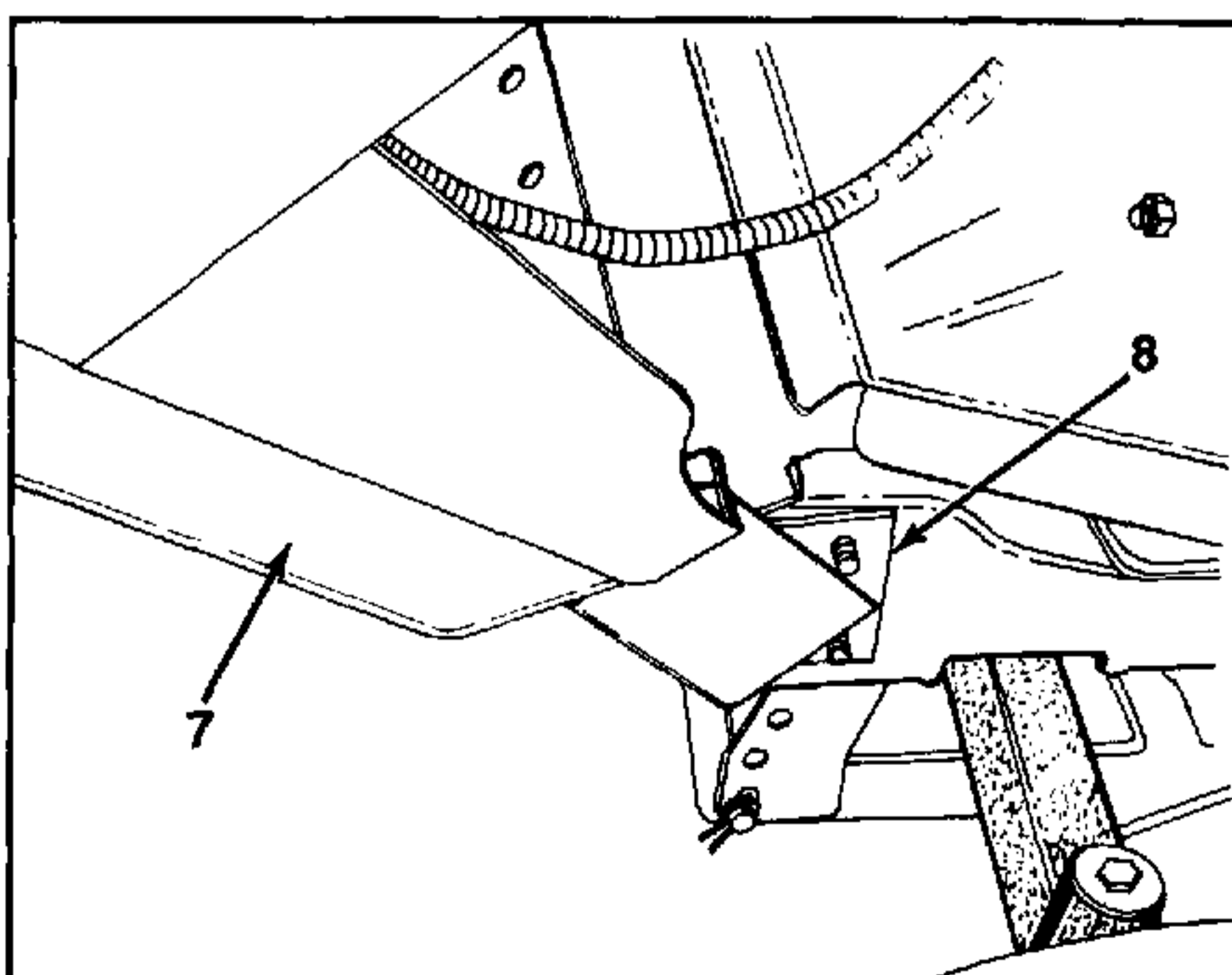

FIGURE 3.

6. Upon removal of extension spring, loosen hex bolts and belleville washers on each side of chassis. See figure 3. Remove one set of bolts and washers from one side only. This will allow you to pull the hood and grille off of the front pivot bracket.

- | |
|--|
| <ol style="list-style-type: none"> 1. Battery Cable—Positive 2. Battery Cable—Negative 3. Battery Tray 4. Extension Springs 5. Cable Tie 6. Headlight Terminals 7. Grille 8. Left Hand Pivot Bracket |
|--|

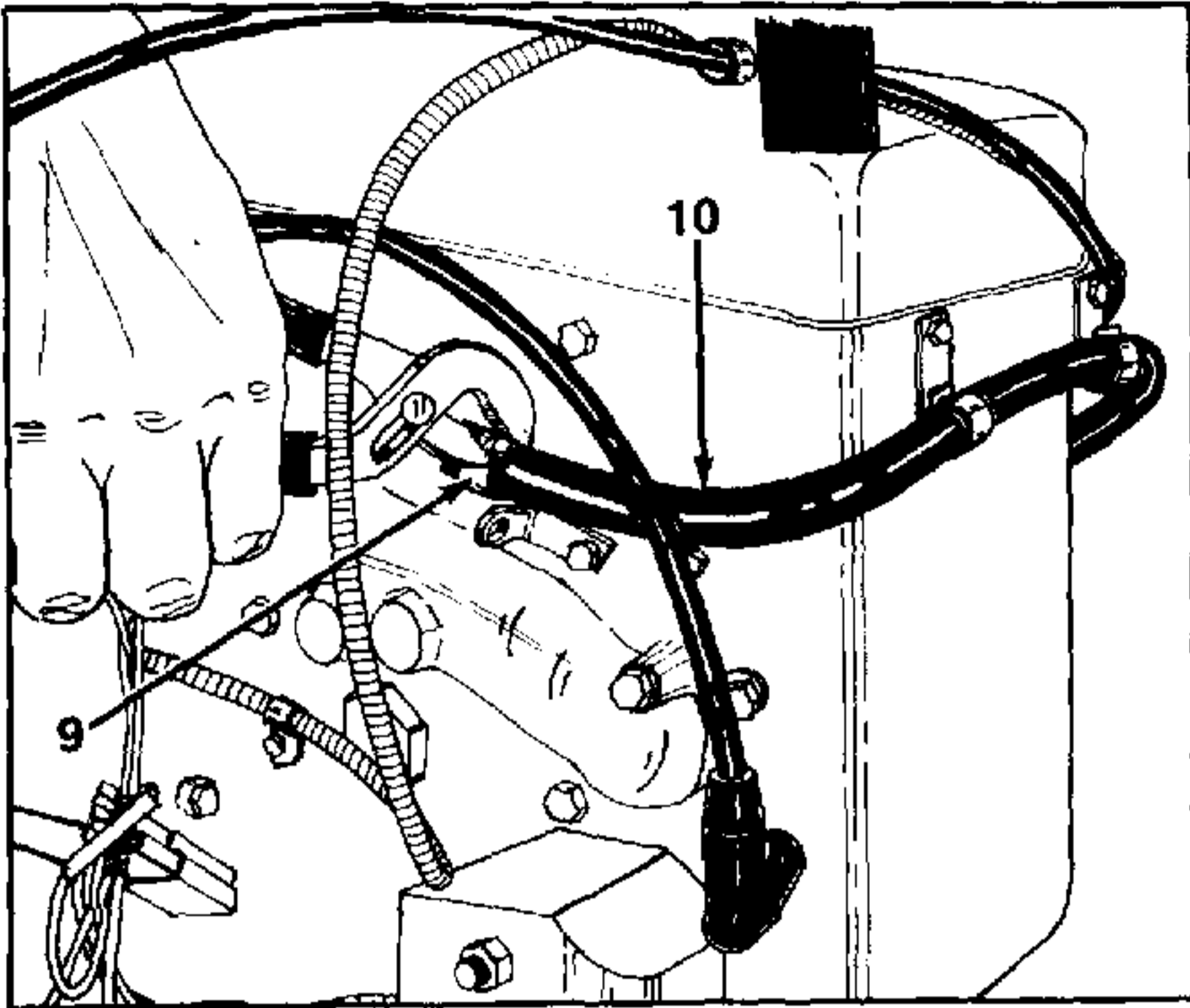

FIGURE 4.

7. Disconnect the fuel line and fuel line clamp from the fuel pump. See figure 4.

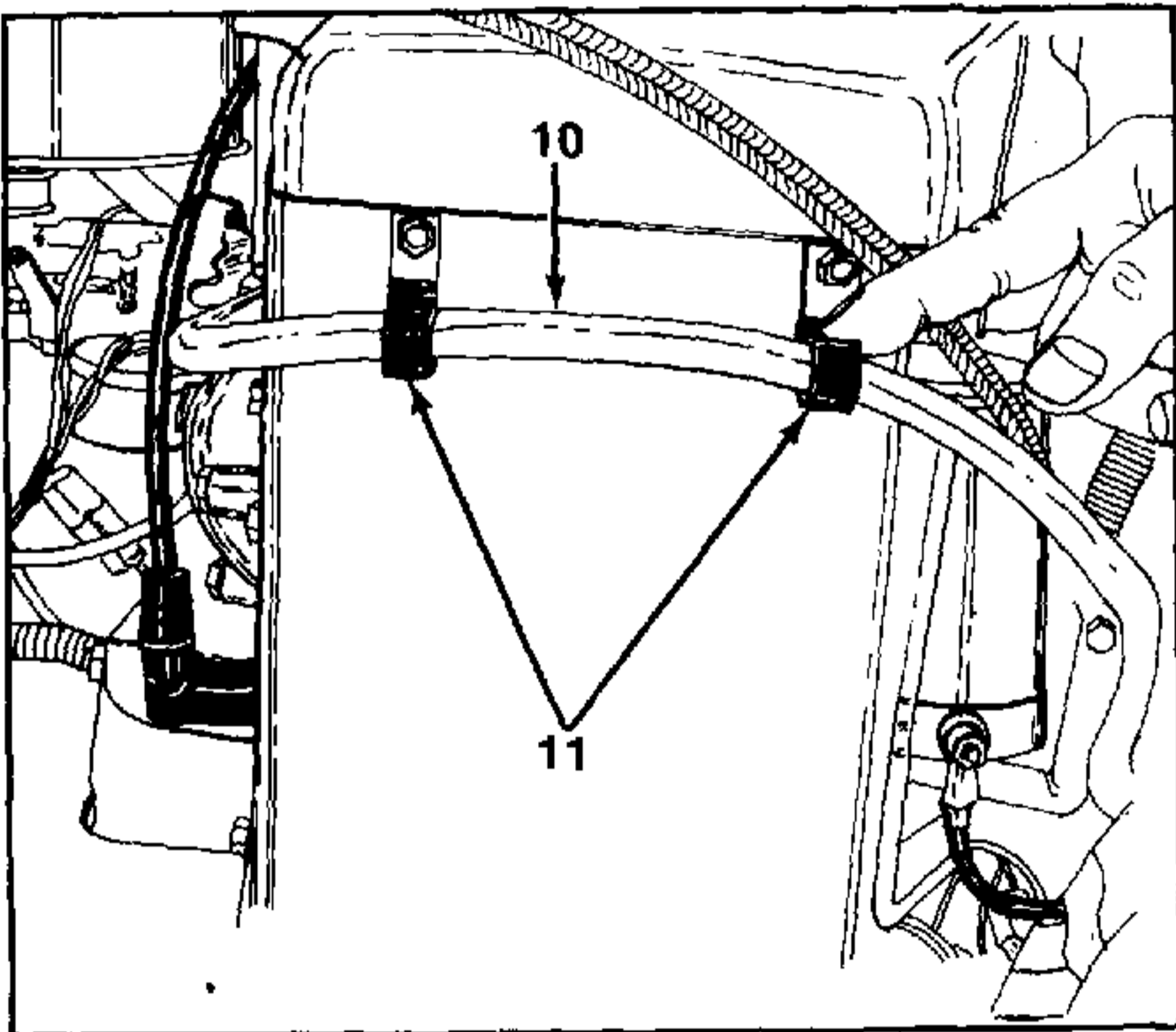

FIGURE 5.

8. Pull the fuel line clip ends downward and pull the fuel line out. See figure 5.

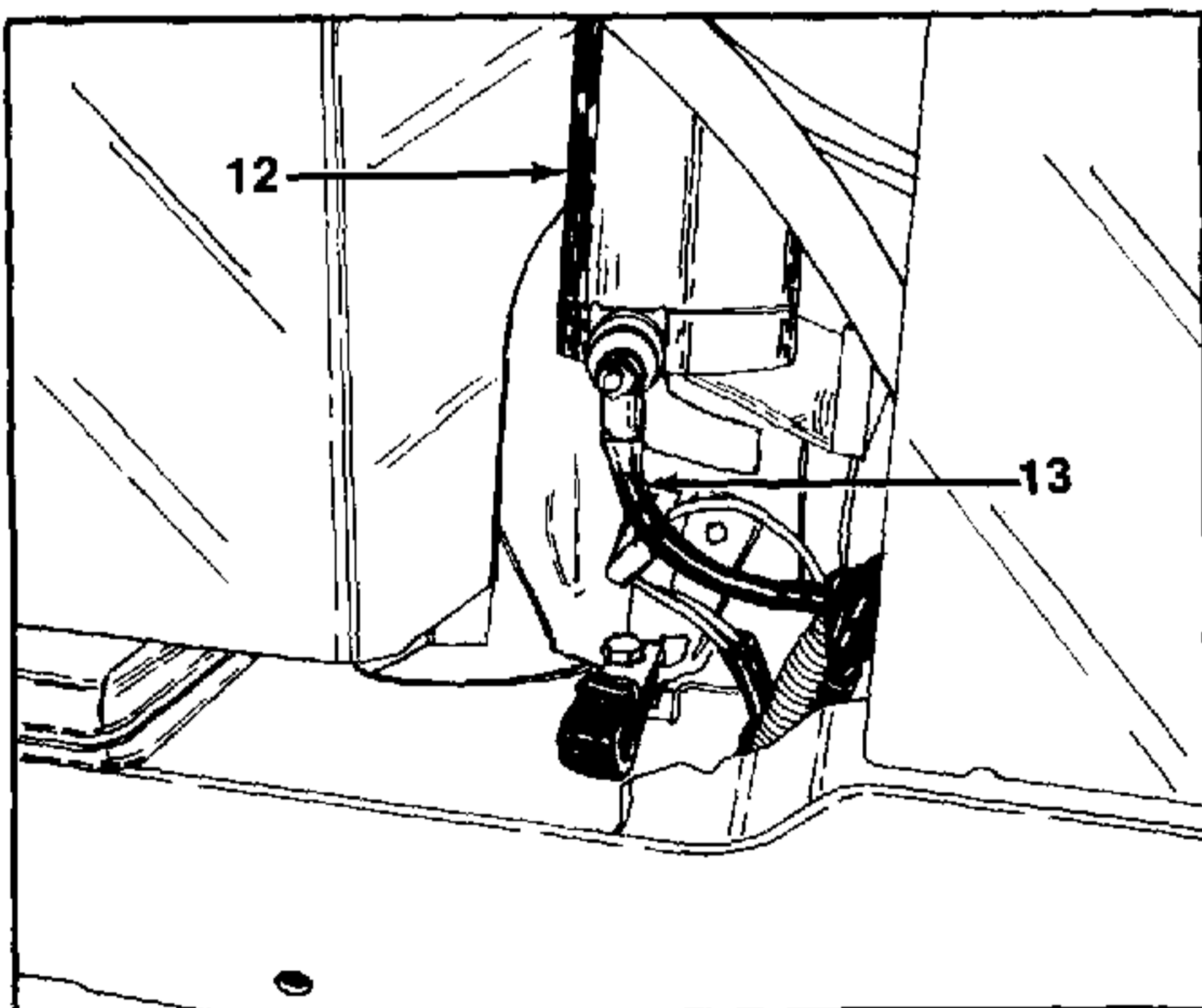

FIGURE 6.

9. Disconnect the starter cable at starter on engine. See figure 6.

- 9. Fuel Line Clamp
- 10. Fuel Line
- 11. Fuel Line Clips
- 12. Starter (On Engine)
- 13. Starter Cable

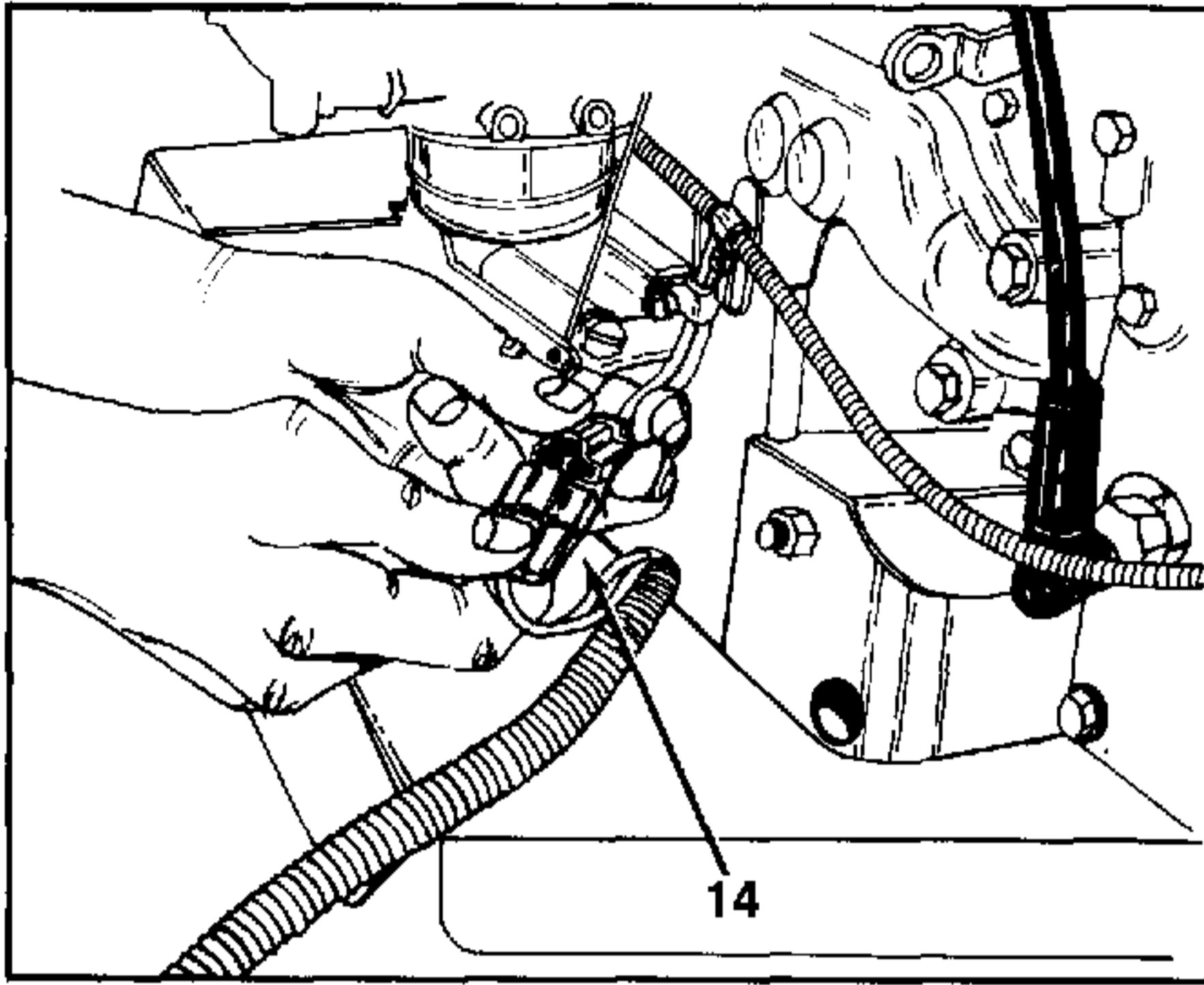

FIGURE 7.

10. Disconnect the main wire harness connection. See figure 7.

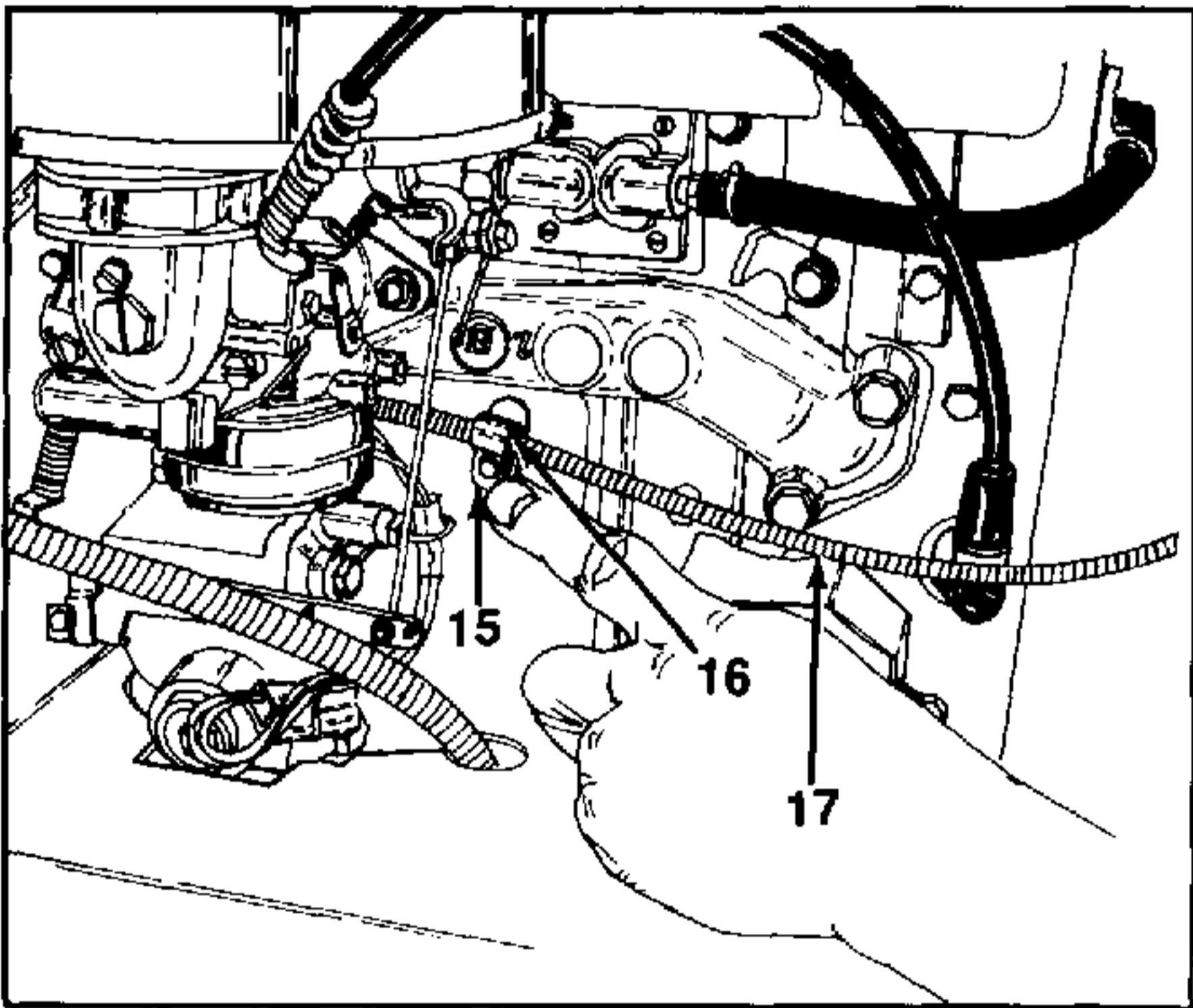

FIGURE 8.

11. Loosen the hex screw at the throttle control clamp. See figure 8.
12. Disconnect the throttle control cable from the front of engine. See figure 8.

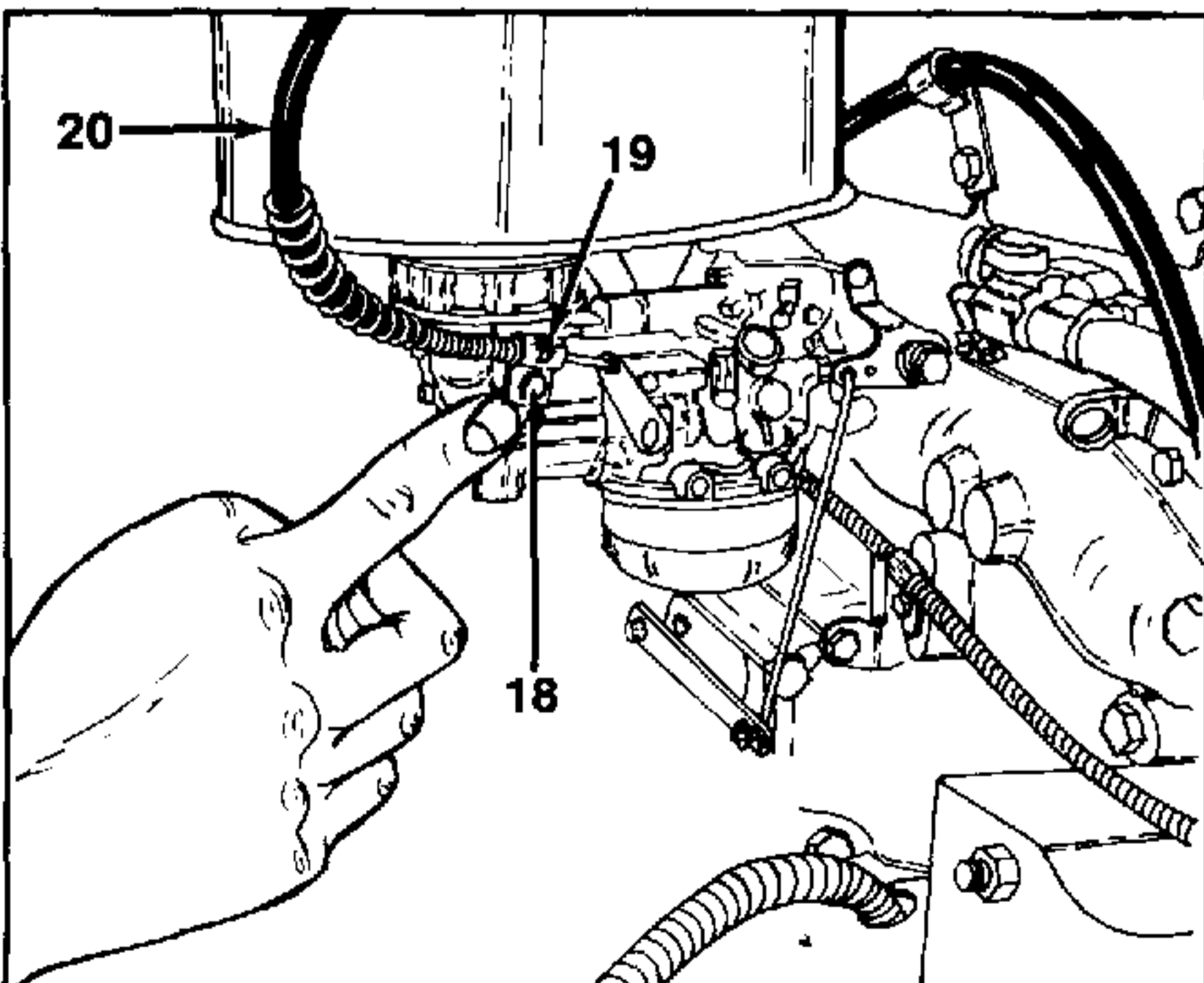

FIGURE 9.

13. Loosen the hex screw at the choke control clamp. See figure 9.
14. Disconnect the choke cable from the front of the engine. See figure 9.

- | |
|---|
| <ul style="list-style-type: none"> 14. Main Wire Harness 15. Hex Screw 16. Throttle Cable Clamp 17. Throttle Cable 18. Hex Screw 19. Choke Cable Clamp 20. Choke Cable |
|---|

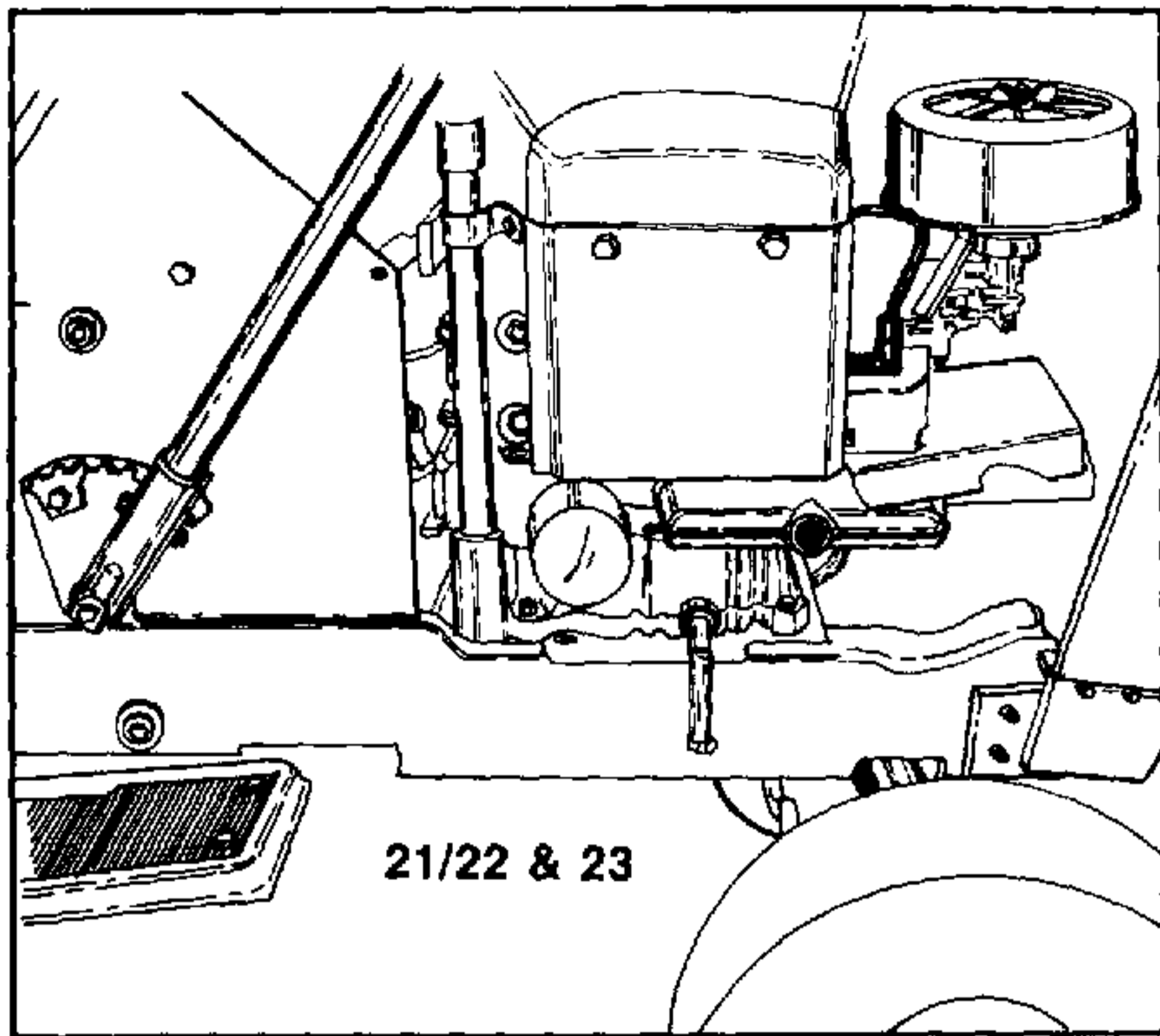

FIGURE 10.

15. Refer to page 1-5, 1-6, 1-7 and figure 19; step 17 on page 1-8 for removal of electric clutch.
16. Now the engine may be unbolted and removed. Remove four hex nuts, lock washers and hex bolts. See figure 10.

Installation

1. Install engine by reversing the removal procedure.
2. Adjust the following as necessary:
 - a. Governor/Throttle Linkage
 - b. Choke Linkage
 - c. Carburetor

<p>21. Hex Nuts (4) 22. Lock Washers (4) 23. Hex Bolts (4)</p>
--

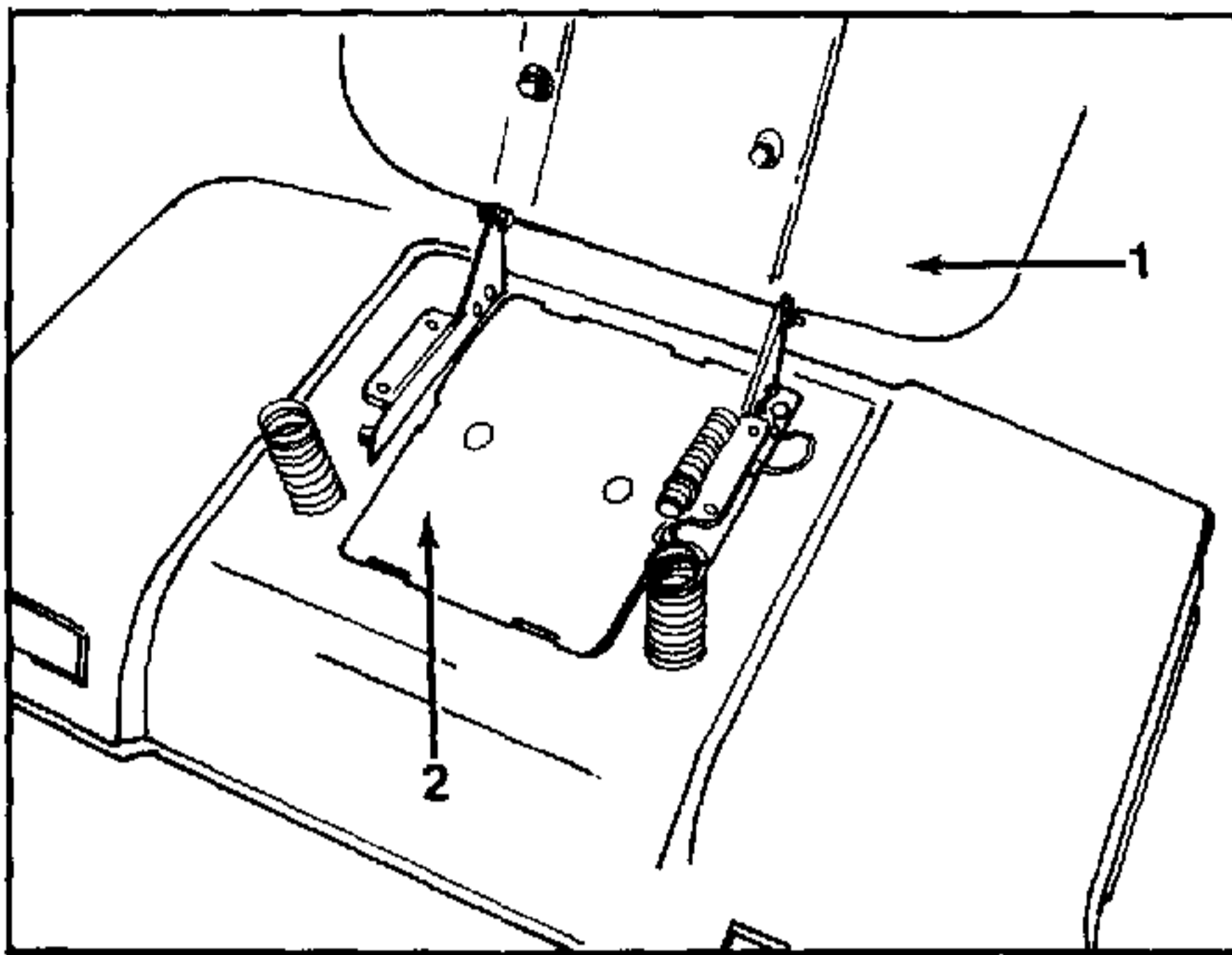

FIGURE 11.

BATTERY REMOVAL, 1989 UNITS

1. Raise the seat.
2. Remove the battery cover, by putting fingers into two holes in battery cover and popping off cover. See figures 11 and 12.
3. Disconnect the battery cable's **negative cable first**, from battery post. See figure 12.

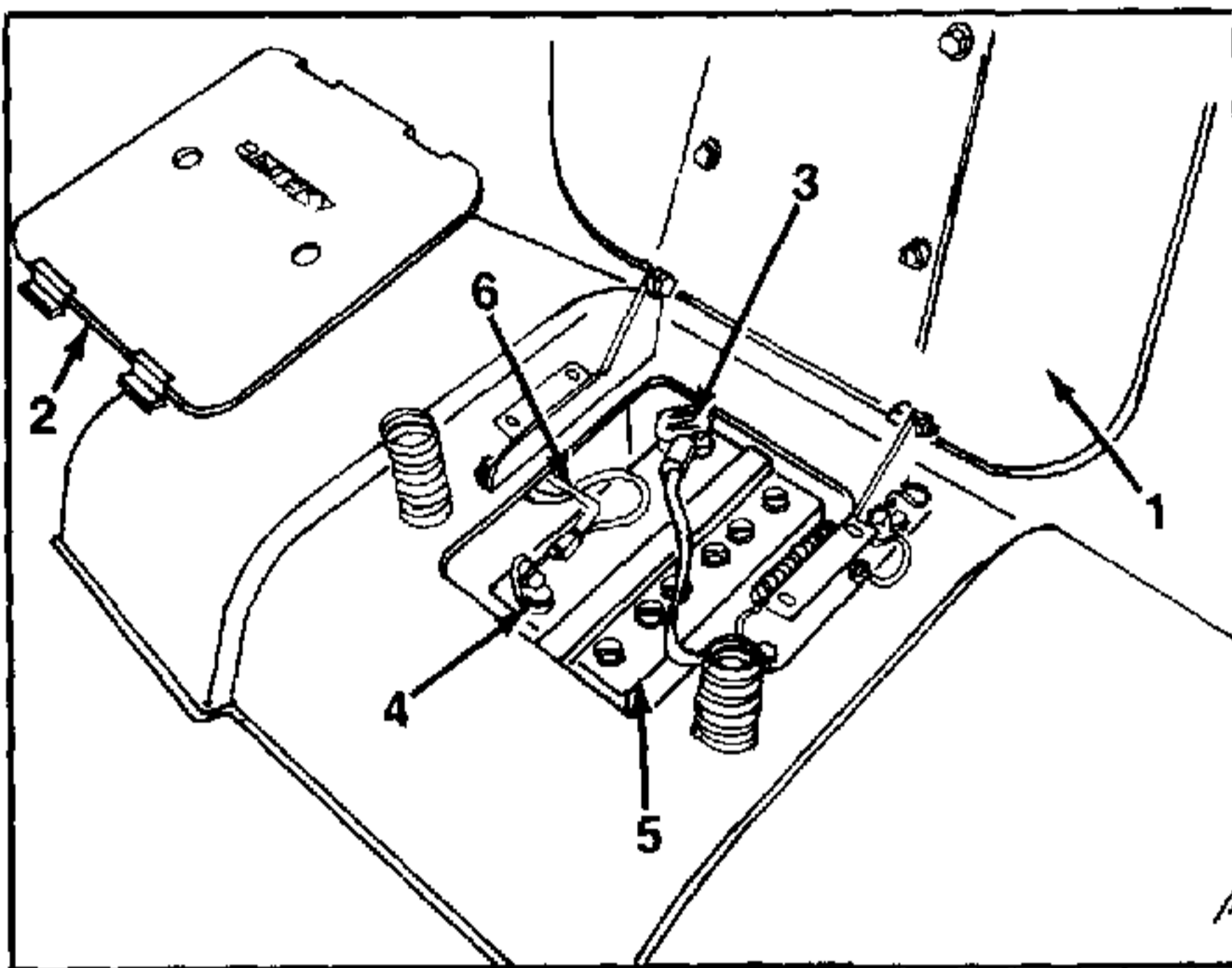

FIGURE 12.

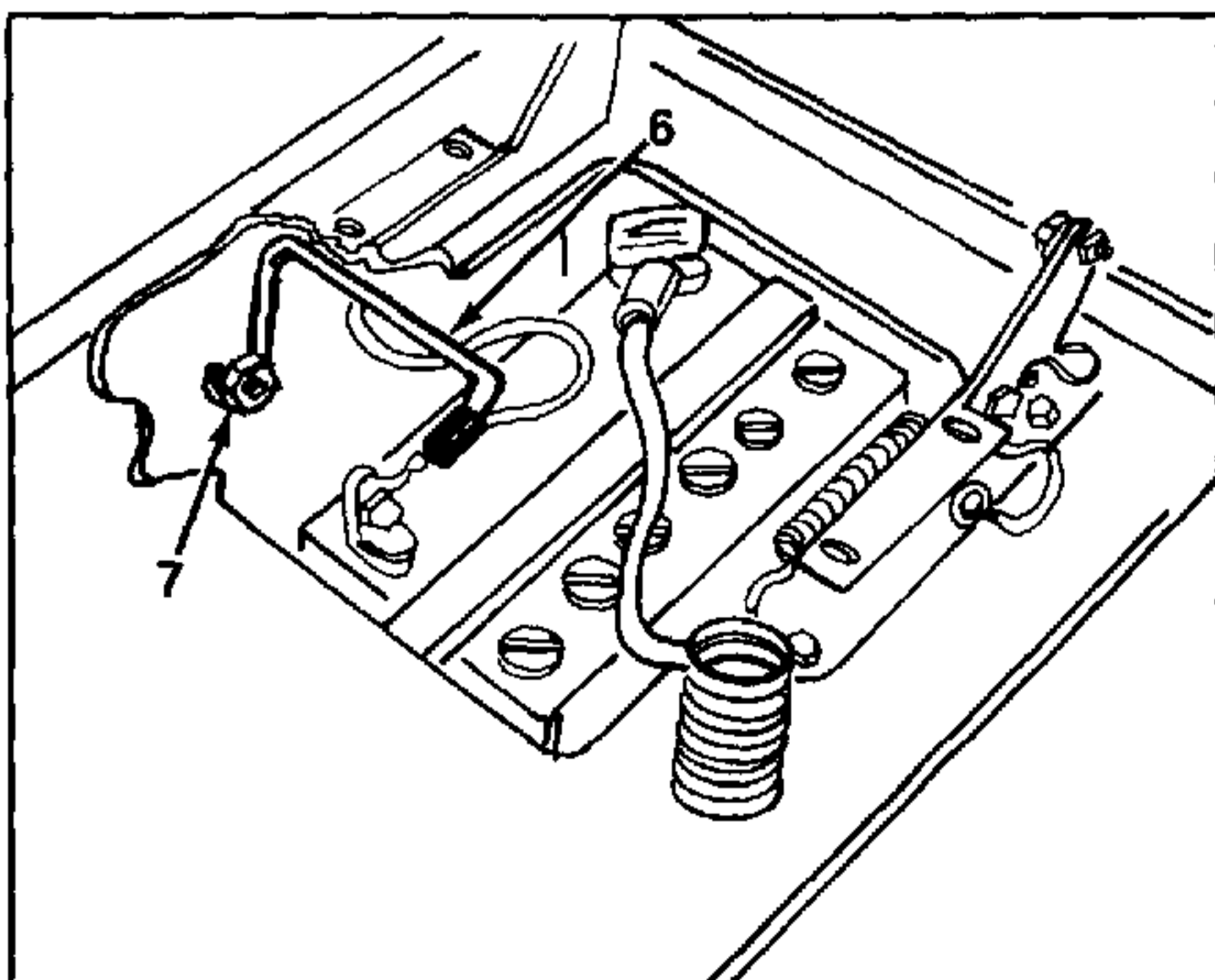

FIGURE 13.

4. Loosen the hex nut holding the battery hold-down rod (located on the left hand fender). See figure 13.
5. Lift out the battery.

- | |
|---|
| <ol style="list-style-type: none"> 1. Seat 2. Battery Cover 3. Battery Cable—Positive 4. Battery Cable—Negative 5. Battery 6. Battery Hold Down Rod 7. Hex Nut |
|---|

Section 2

CHASSIS

Contents

Steering Assembly Removal & Disassembly	2 2
Inspection and Repair	2-6
Reassembly	2 6 and 2-7
Front Axle Assembly	
Removal and Disassembly	2 8
Inspection	2 9
Reassembly	2 9
5 Speed Transaxle Removal	2 11
Hydrostatic Transmission Removal	2 29
Hydrostatic Transmission (Sundstrand) Disassembly and Assembly	2 43
Hydrostatic Rear Axle (Cub Cadet)	2 72
Hydrostatic Controls and Adjustments	2 83
Adjusting Brakes	2 83
Drive Belt Replacement	2 84
Replacement of Friction Washer	2 85

STEERING ASSEMBLY

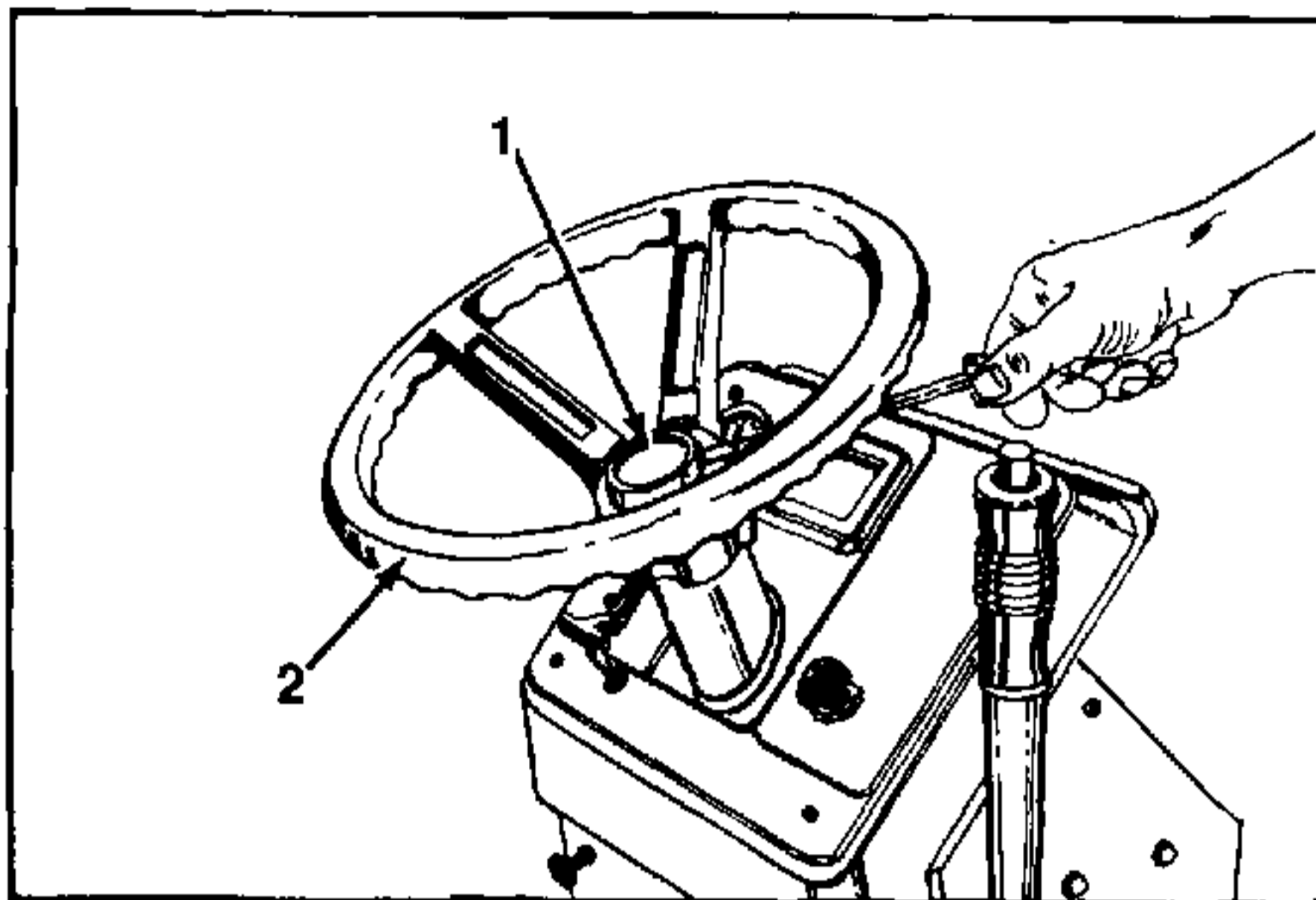

FIGURE 1.

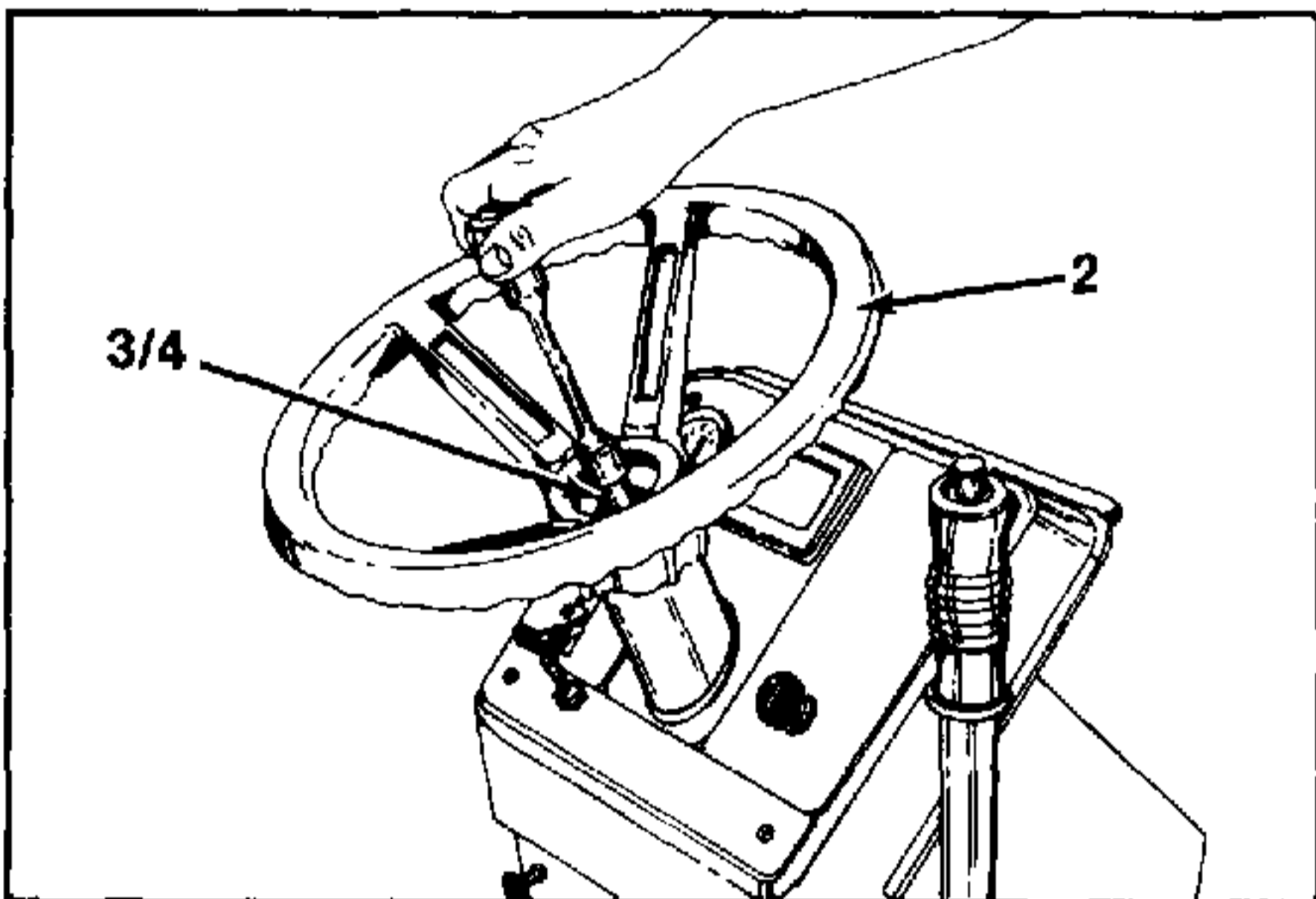

FIGURE 2.

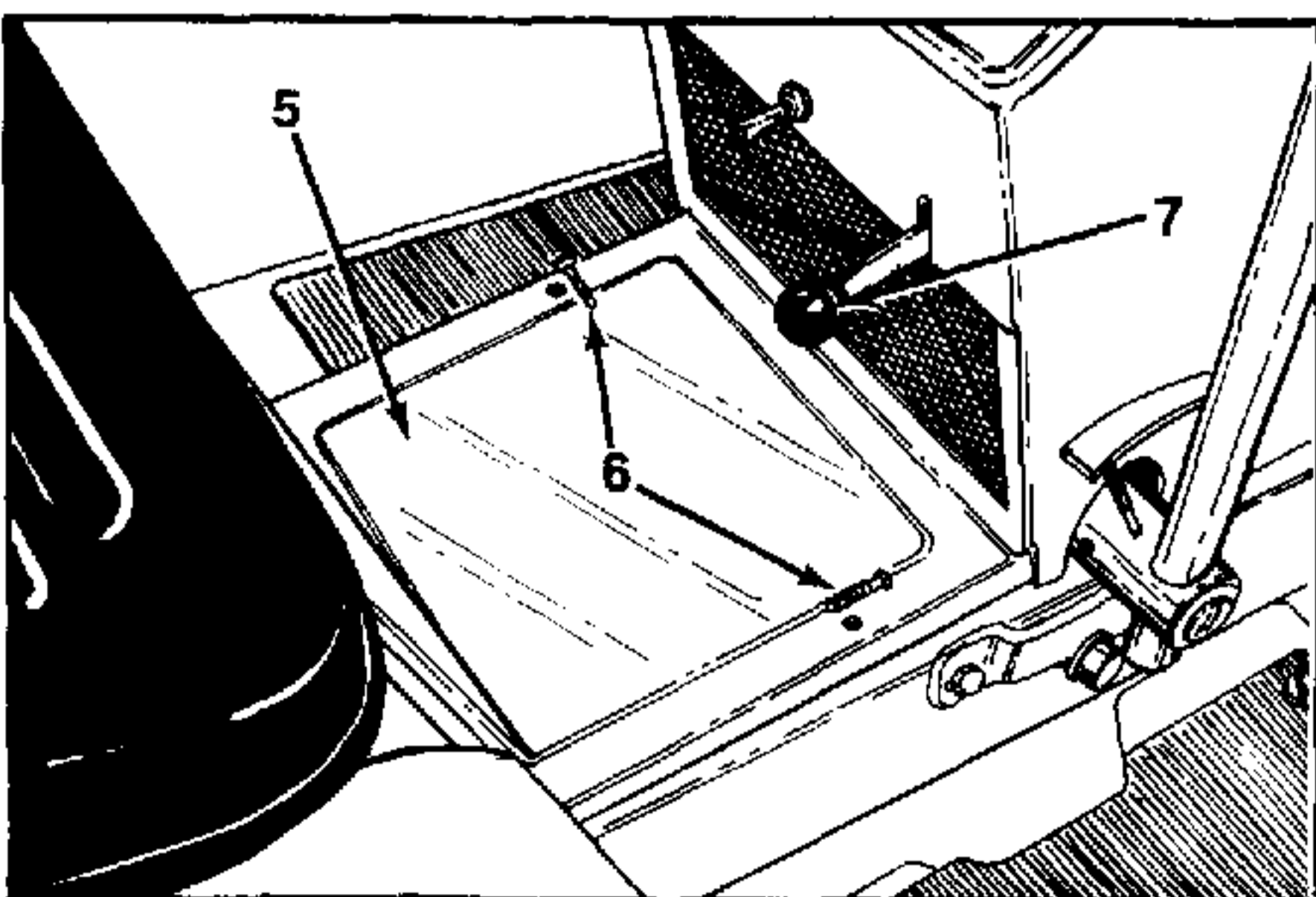

FIGURE 3.

REMOVAL AND DISASSEMBLY

1. With a screwdriver or suitable tool, remove the steering wheel cap (Ref. 1). Start to pry cap up and it will pop off. See figure 1.
2. Remove the steering wheel by removing the hex lock nut (Ref. 3) and belleville washer (Ref. 4). See figure 2. Pull and tap steering wheel upwards to remove. A hammer may be required.

NOTE: If steering wheel shaft assembly and/or pinion gear are the only parts being removed for replacement or inspection, proceed directly to step 3, page 2-6 under steering shaft bushing replacement.

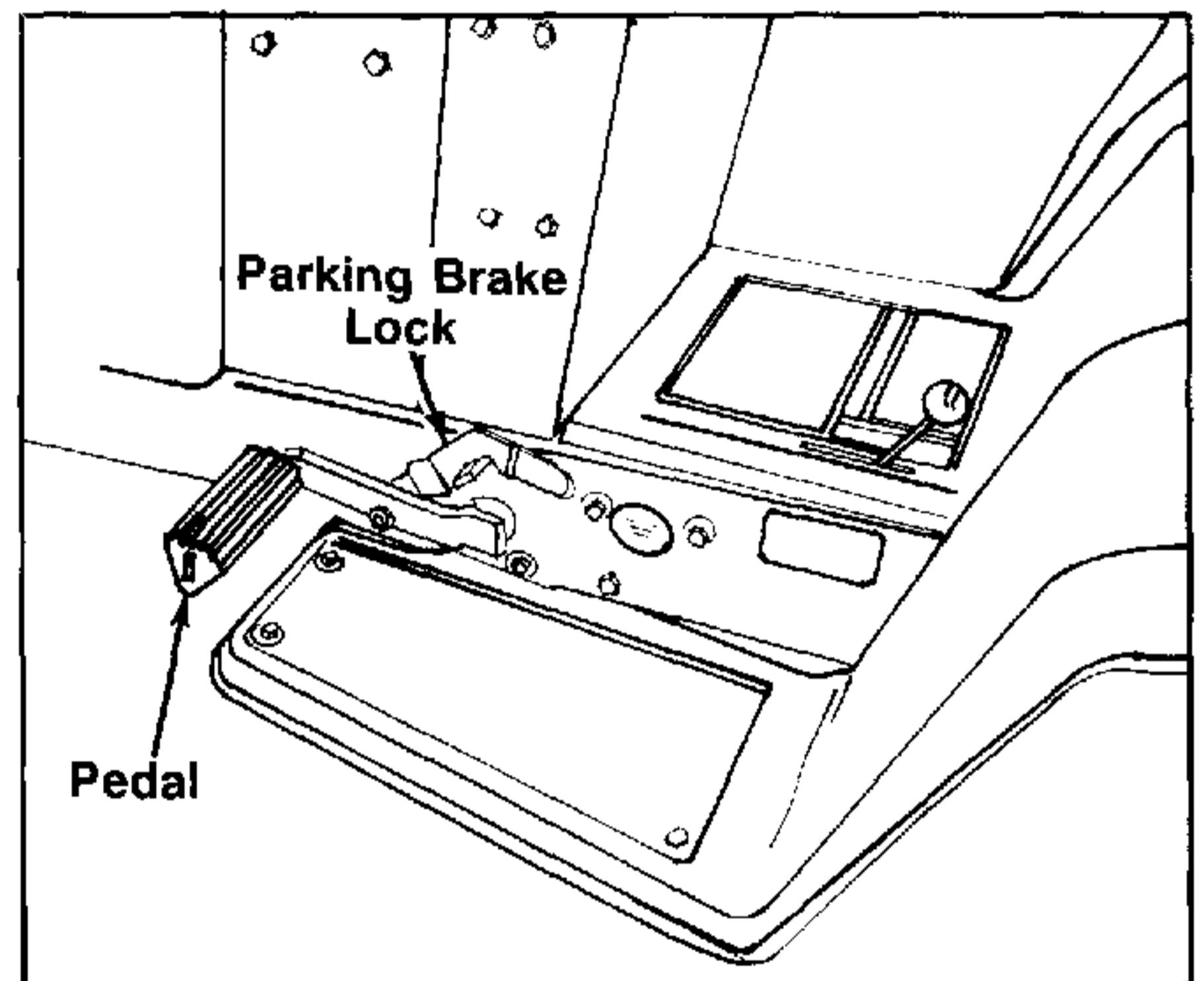

FIGURE 3A.

3. Remove single hex bolt at rear of frame cover. Loosen one of the seat hinge brackets. Disconnect the two wire harness connector to the seat switch and remove the seat. Remove the frame cover panel (Ref. 5) by removing two self-tapping screws (Ref. 6). See figure 3.
4. Unscrew the parking brake knob and remove (Ref. 7). See figure 3. **NOTE:** Parking brake "Lock" is at pedal on 1988 and 1989 units. See figure 3A.

1. Steering Wheel Cap
2. Steering Wheel
3. Hex Lock Nut
4. Belleville Washer
5. Dash Panel Cover
6. Self-Tapping Screws
7. Parking Brake, Knob

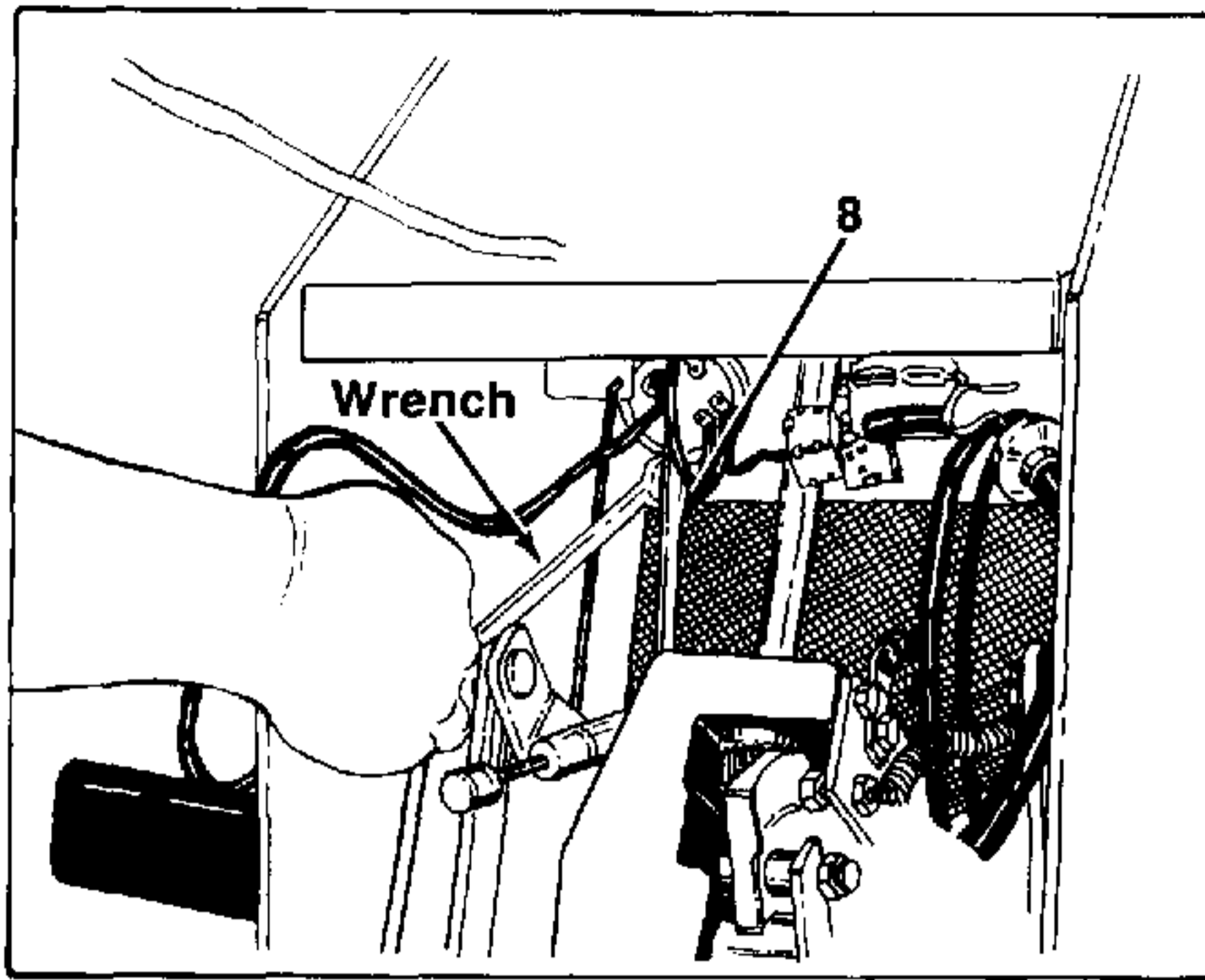

FIGURE 4.

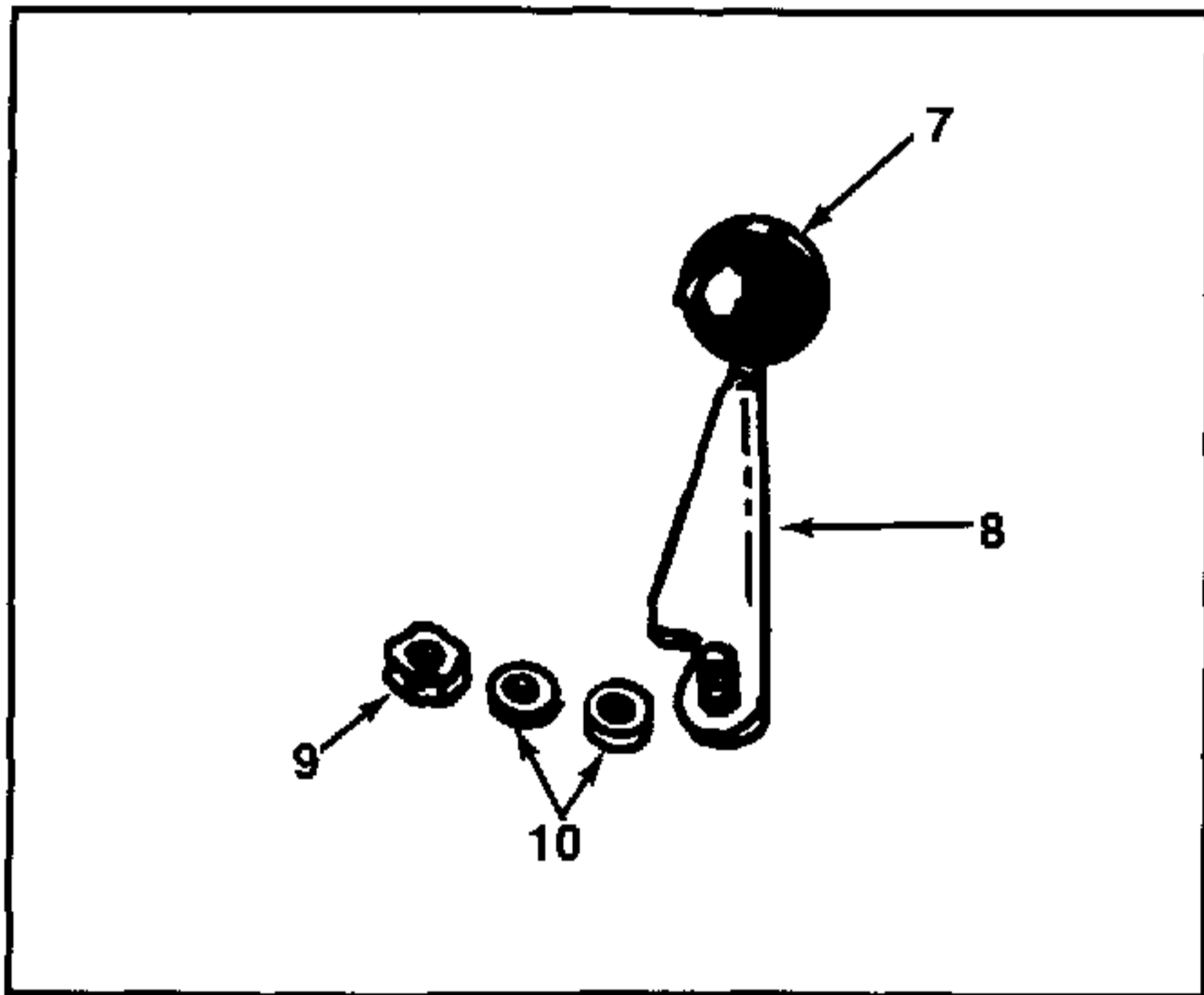

FIGURE 5.

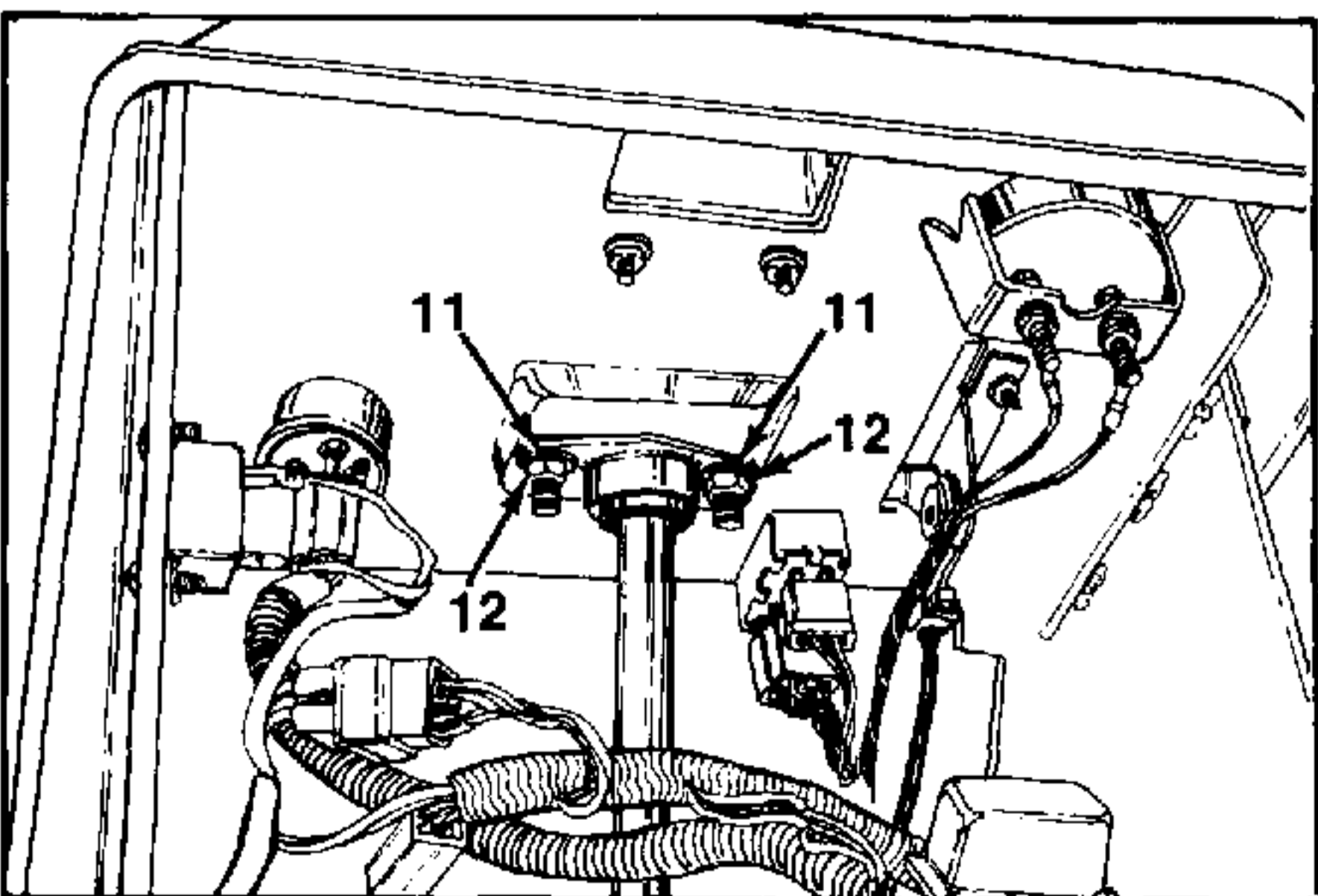

FIGURE 6.

NOTE: Engine removed for clarity only. Engine removal not necessary.

5. Reach inside the right hand side of pedestal assembly and remove hex nut (Ref. 9) and two flat washers (Ref. 10) from parking brake lever (Ref. 8). See figures 4 and 5.
6. Remove the battery. (Refer to page 1-2.)
7. Disconnect the following cable and harness connections.
 - a. Throttle Cable (pg. 1-4, step 7)
 - b. Choke Cable (pg. 1-4, step 6)
 - c. PTO Electric Clutch Harness (pg. 1-5, step 10)
 - d. Engine Ground Wire (pg. 1-4, step 8)
 - e. Main Harness/Charging System (pg. 1-5, step 9)
 - f. Starter Cable (pg. 1-5, step 9)

➔ NOTE

Removal of fuel tank for 1015, 1020 and all 1989 units is shown on page 4-8 of this manual.

8. Remove two hex nuts (Ref. 12) and lock washers (Ref. 11) from the inside of dash assembly at steering shaft bearing. See figure 6.

- | |
|--|
| <ol style="list-style-type: none"> 7. Parking Brake, Knob 8. Parking Brake Lever 9. Hex Nut 10. Flat Washers 11. Lock Washers 12. Hex Nuts |
|--|

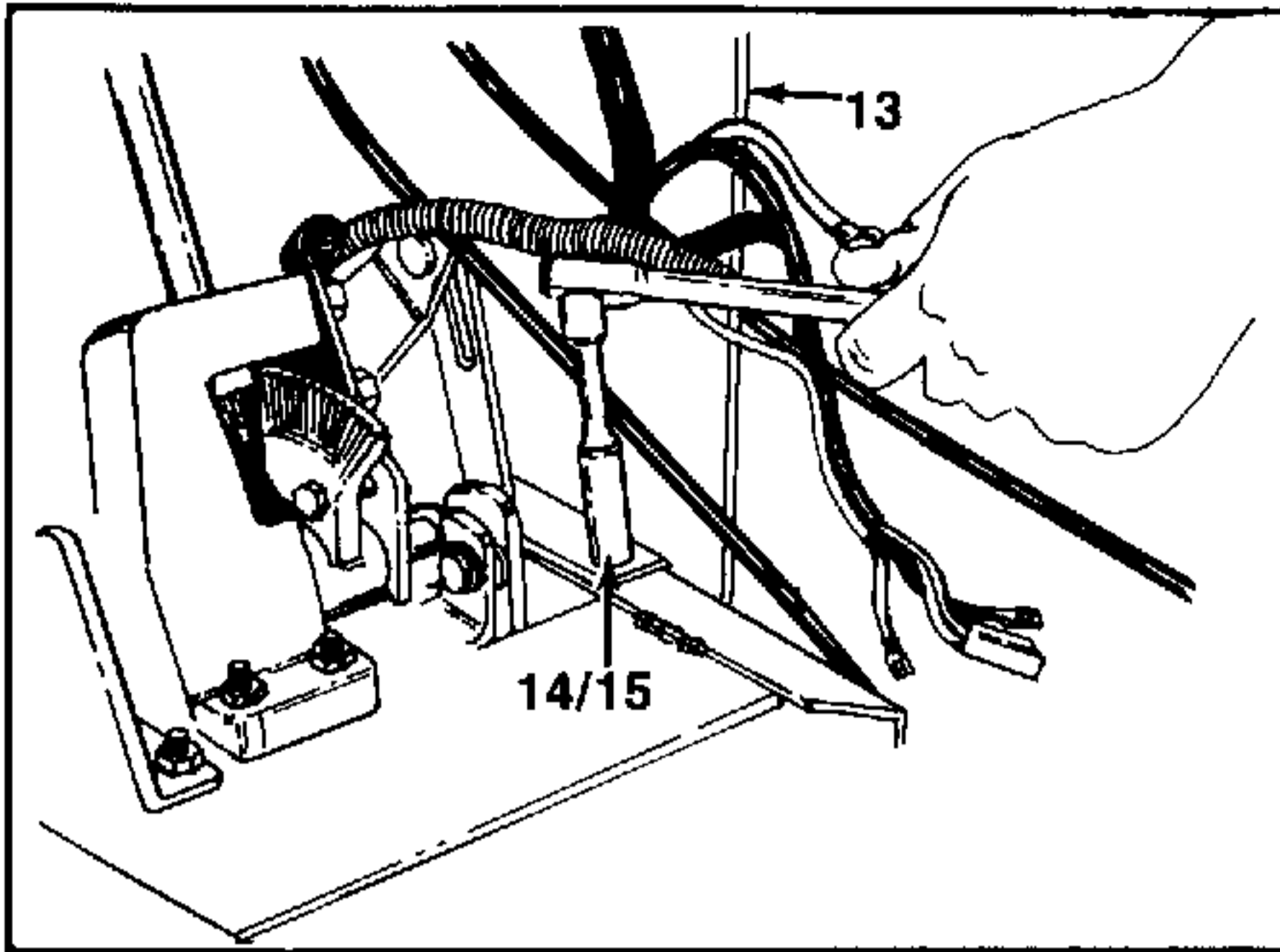

FIGURE 7.

9. Remove the four hex nuts (Ref. 14) and lock washers (Ref. 15) that hold the pedestal to the frame. See figure 7.
10. Lift pedestal up over steering shaft and lay across frame in front of fenders.

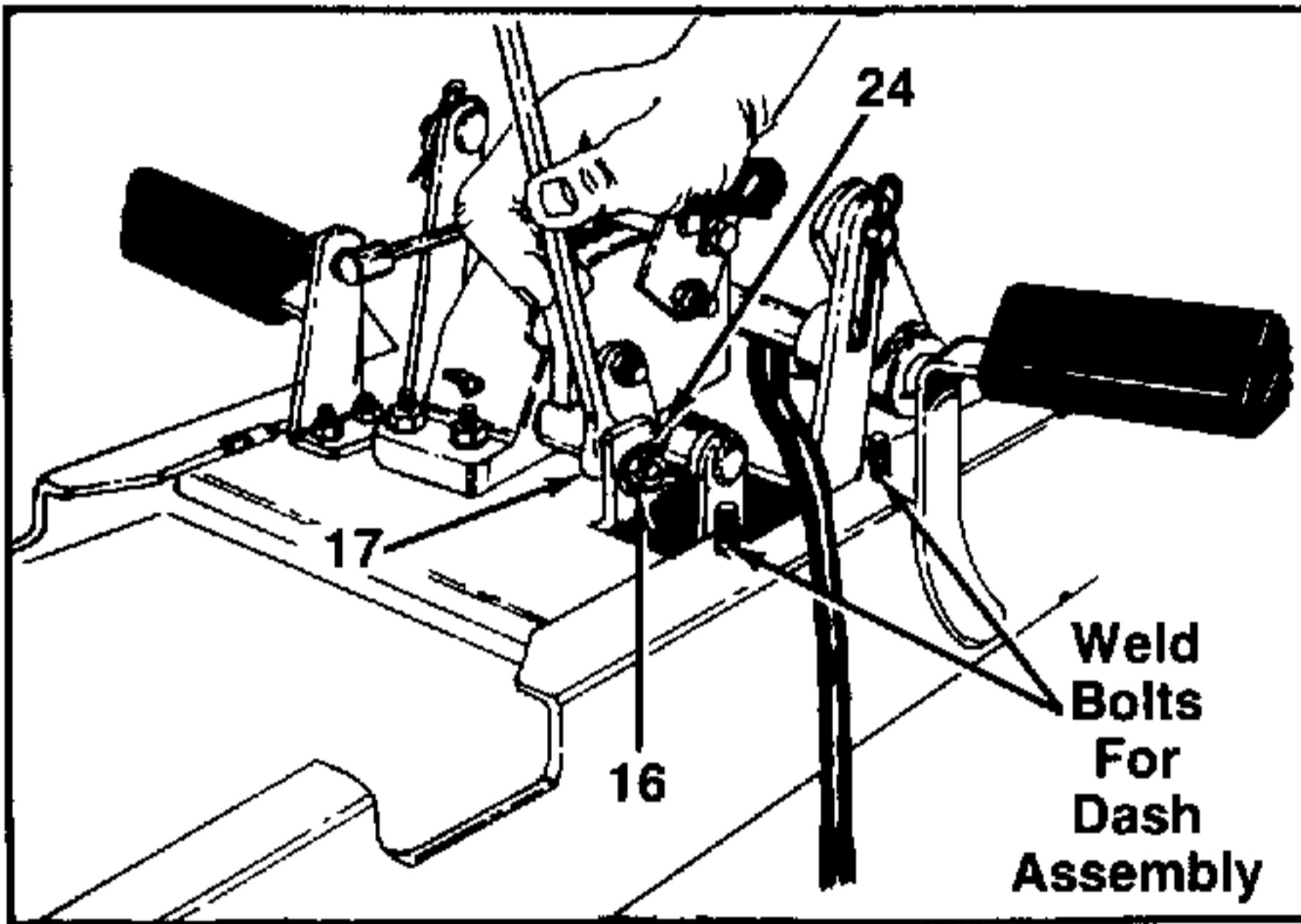

FIGURE 8.

11. Remove the nut (Ref. 16) and bolt (Ref. 17) holding the flange bearing (Ref. 24) to the chassis. See figure 8.

NOTE

Figure 8 shows two pedals; there is only one pedal on 1988 and 1989 models. Refer to figure 3A, on page 2-2 for reference.

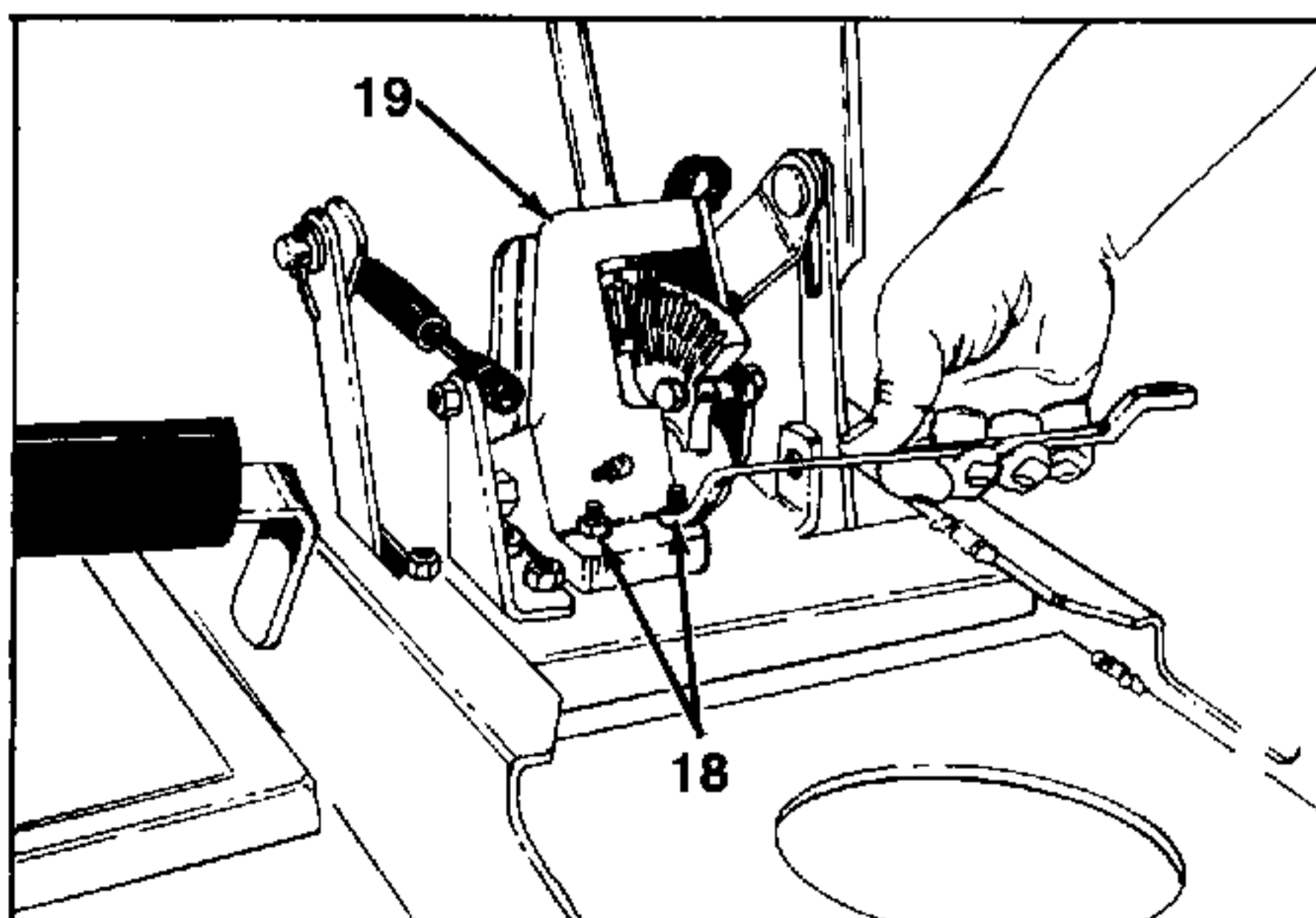

FIGURE 9.

12. Remove the steering assembly (Ref. 19) from the tractor frame by removing four hex nuts (Ref. 18). See figure 9.

- | |
|-----------------------|
| 13. Dash Assembly |
| 14. Hex Nuts |
| 15. Lock Washers |
| 16. Hex Lock Nut |
| 17. Hex Bolt |
| 18. Hex Nuts |
| 19. Steering Assembly |

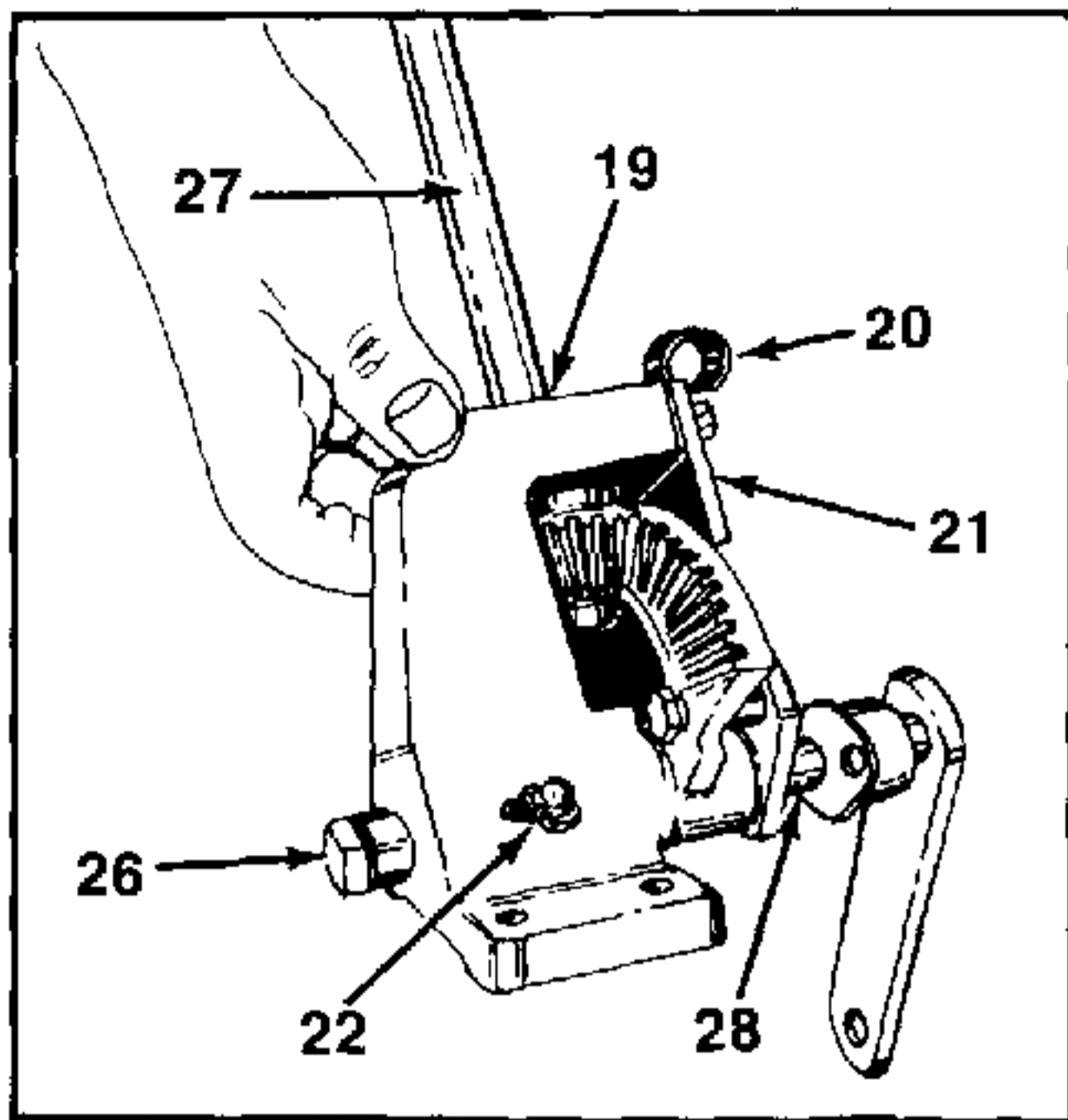

FIGURE 10.

13. Once you have removed the steering assembly from the tractor, inspect parts for wear or damage and replace if necessary. See figures 10, 11 and 12.

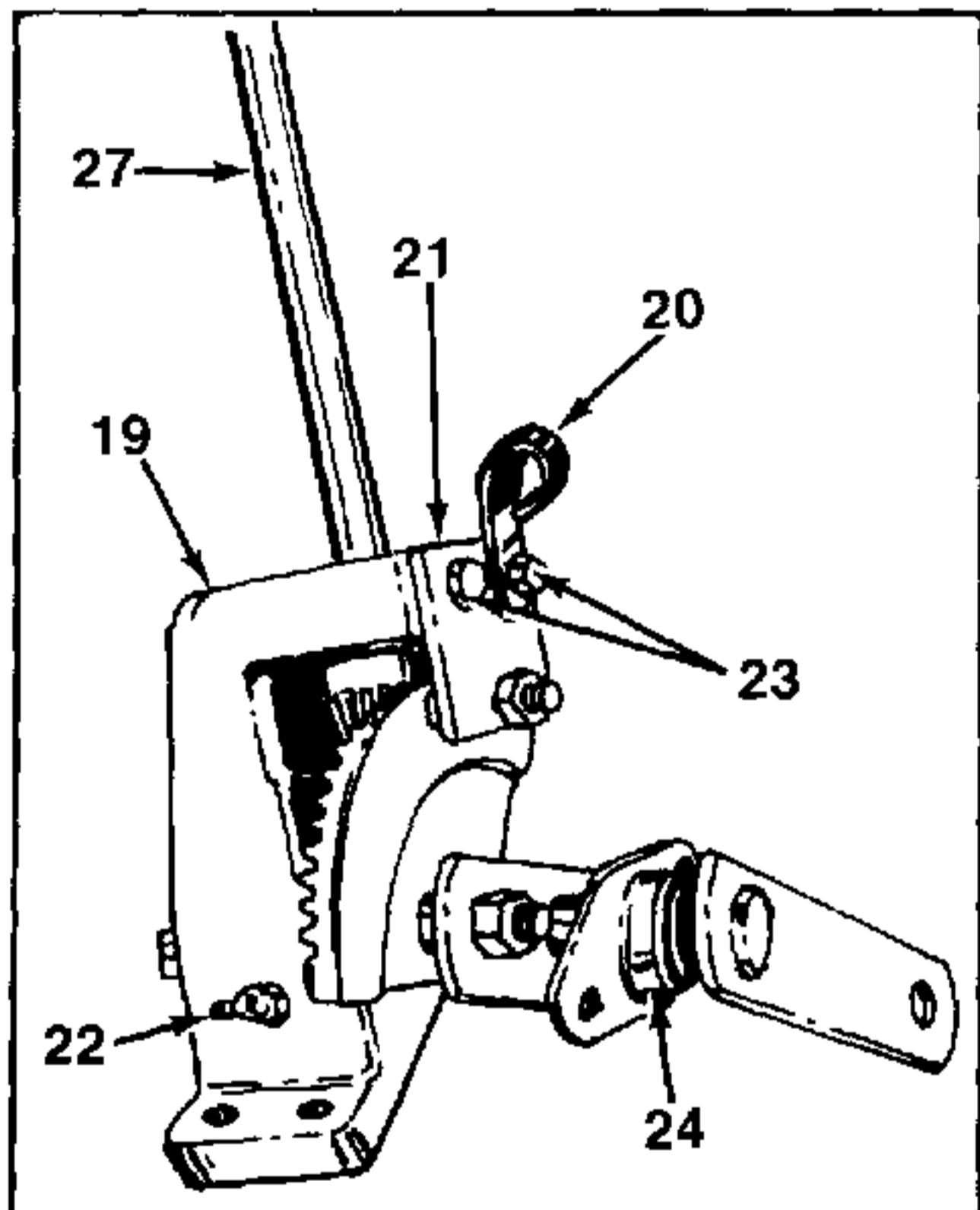

FIGURE 11.

14. Remove the back-up plate (Ref. 21) by removing two hex bolts (Ref. 23). NOTE: Cable clamp (Ref. 20) will come off at this time. Upon reassembly of back-up plate, make certain it is turned upward as shown in figure 11.

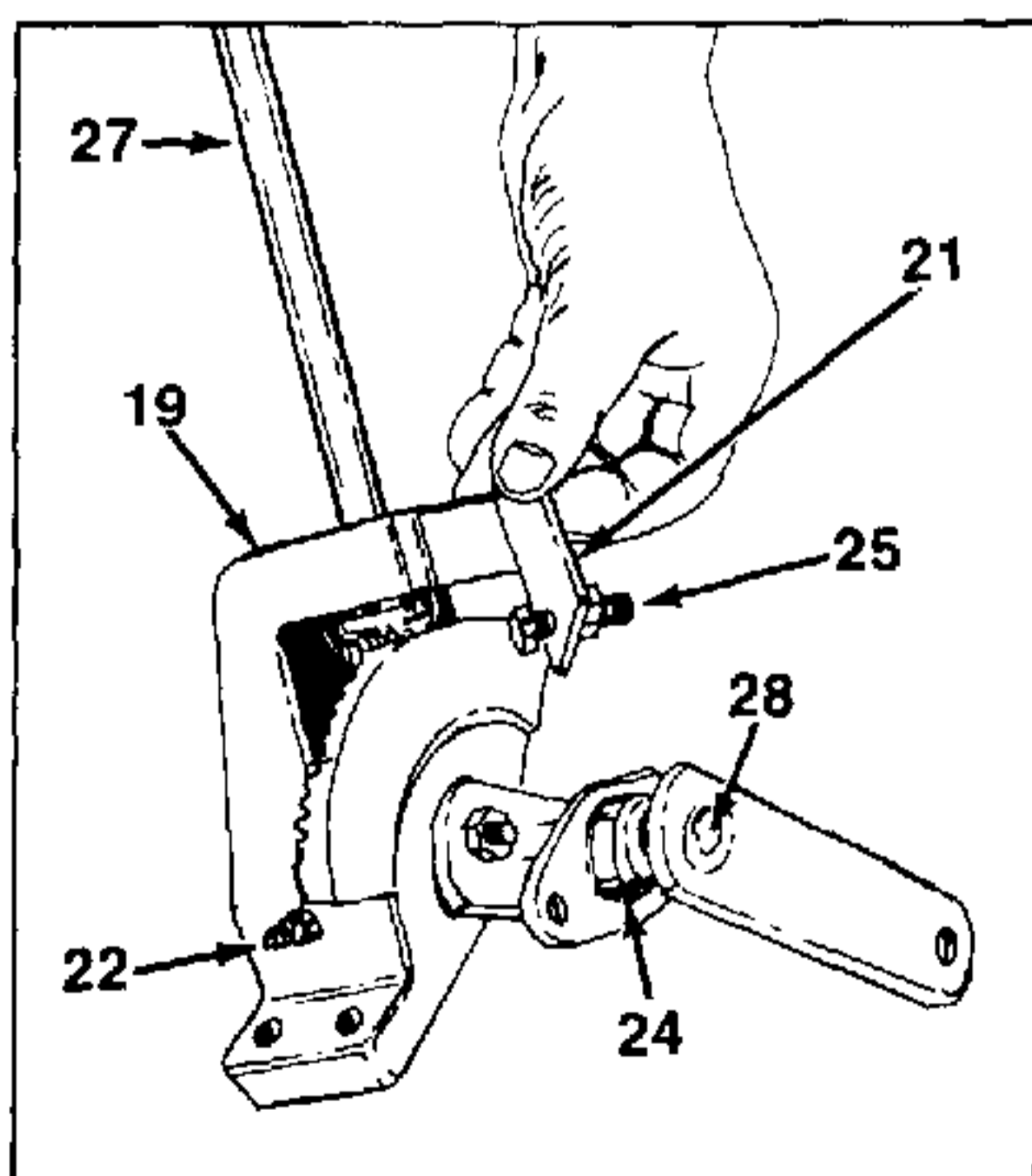
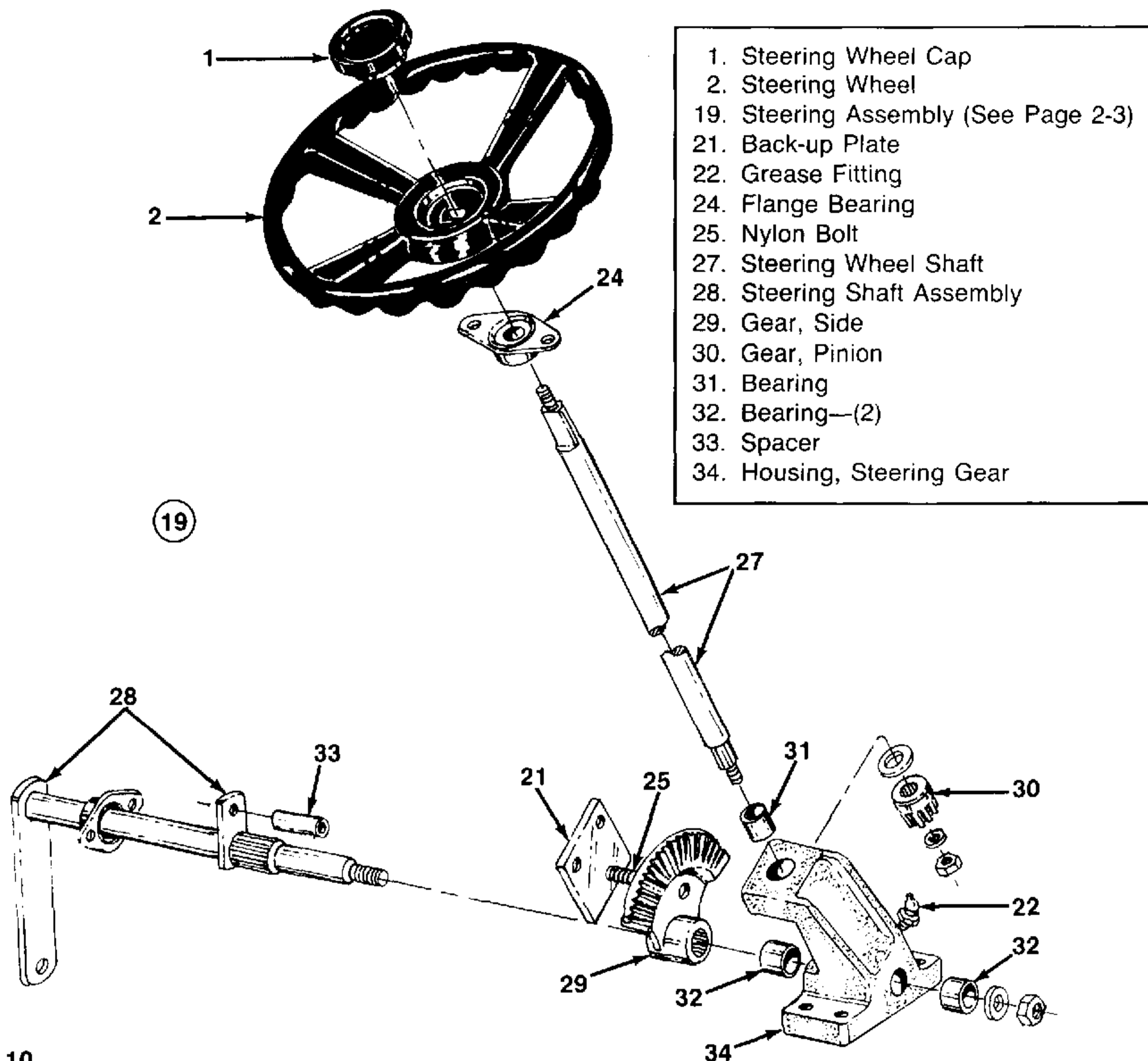

FIGURE 12.

15. Nylon bolt (Ref. 25) can now be adjusted for side play in steering gear and/or replaced if head of bolt is worn too badly.
16. To remove the steering shaft (Ref. 28), remove the hex nut (Ref. 26) and slide out. Now inspect the flange bearing (Ref. 24). Replace if necessary. Inspection and repair of steering parts, see page 2-6.

- | |
|-----------------------------|
| 19. Steering Assembly |
| 20. Cable Clamp |
| 21. Back-Up Plate |
| 22. Grease Fitting |
| 23. Hex Bolts |
| 24. Flange Bearing |
| 25. Nylon Bolt |
| 26. Hex Nut |
| 27. Steering Wheel Shaft |
| 28. Steering Shaft Assembly |

STEERING/PRIOR TO 1988 INSPECTION AND REPAIR



- 1. Steering Wheel Cap
- 2. Steering Wheel
- 19. Steering Assembly (See Page 2-3)
- 21. Back-up Plate
- 22. Grease Fitting
- 24. Flange Bearing
- 25. Nylon Bolt
- 27. Steering Wheel Shaft
- 28. Steering Shaft Assembly
- 29. Gear, Side
- 30. Gear, Pinion
- 31. Bearing
- 32. Bearing—(2)
- 33. Spacer
- 34. Housing, Steering Gear

FIGURE 10.

INSPECTION AND REPAIR

1. Wash all parts in clean solvent and dry thoroughly.
2. Inspect the nylon bearing and bushings for wear or damage. Replace as necessary.

➔ NOTE

See page 2-6 for steering shaft bushing replacement procedure.

3. Check for broken teeth, bent shafts and stripped threads. Replace the damaged parts.

REASSEMBLY AND INSTALLATION

1. Reassemble and install by reversing the removal and disassembly procedure. Apply Cub Cadet multi-purpose grease or equivalent liberally to the gear assembly, bearings and shaft.

STEERING SHAFT BUSHING REPLACEMENT

1. Remove the back-up plate from steering gear housing. Inspect the head of nylon bolt for excessive wear. Replace if necessary.
2. Remove the hex nut and washer at the end of the steering shaft (Ref. 28) and pull the steering shaft out of the steering gear housing.

NOTE: Side gear (Ref. 29) will be attached to steering shaft assembly (Ref. 28).

3. Remove hex nut and flat washer on end of steering wheel shaft assembly (Ref. 27).
4. Pull steering shaft assembly out of housing and gear.
5. With the front wheels straight ahead, install the steering assembly. Be sure the pinion gear on the steering shaft is in the center of the side gear (Ref. 29). Install hex nut and flat washer.

STEERING/1988 AND 1989 UNITS INSPECTION AND REPAIR

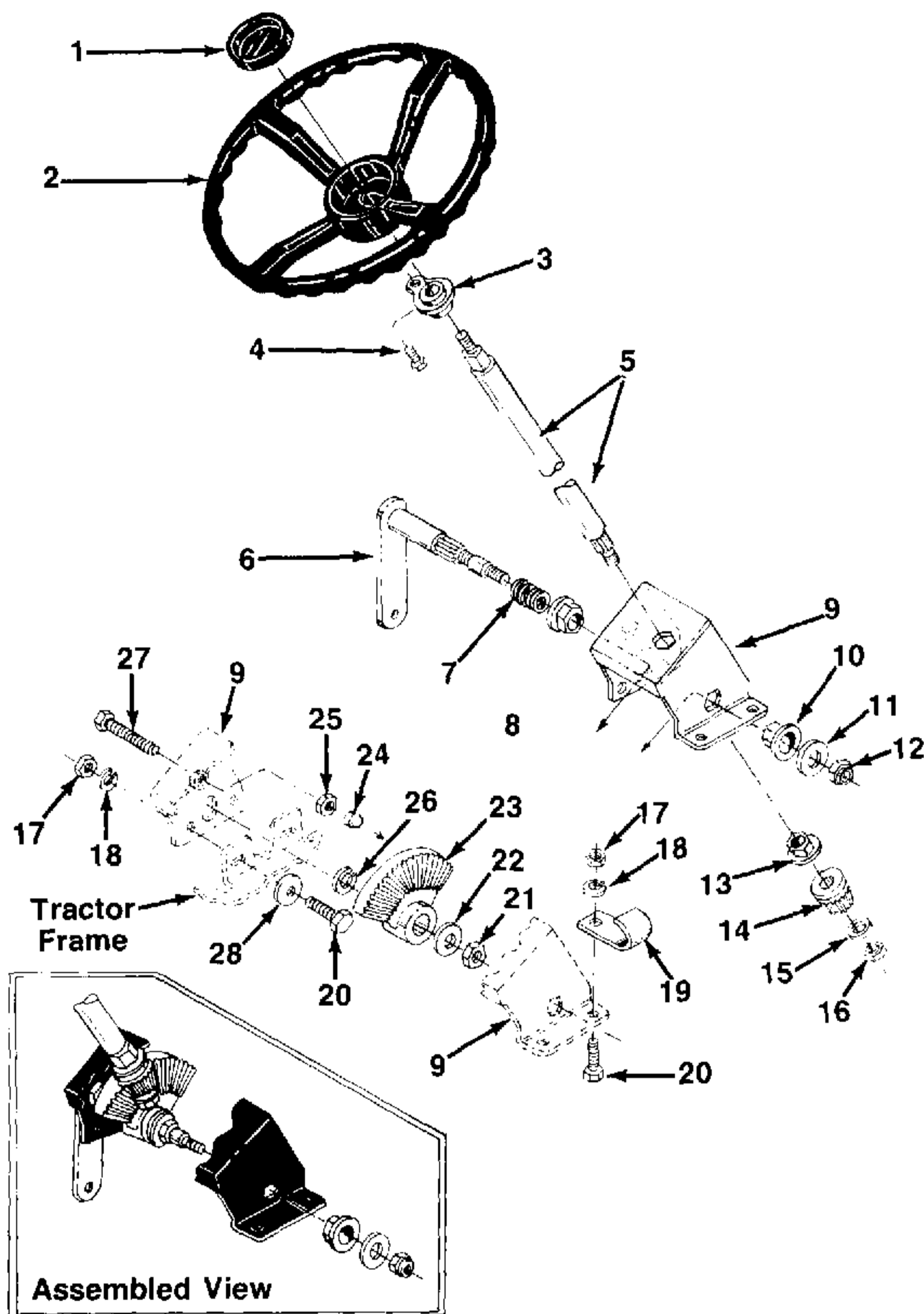

- 1. Steering Wheel Cap
- 2. Steering Wheel
- 3. Steering Column Bearing
- 4. Oval Hd. #10 Screw
- 5. Steering Wheel Shaft
- 6. Steering Shaft
- 7. Compression Spring
- 8. Flange Bearing
- 9. Steering Box
- 10. Flange Bearing
- 11. Flat Washer
- 12. Hex Center Lock Nut
- 13. Flange Bearing
- 14. Pinion Gear
- 15. Flat Washer
- 16. Hex Center Lock Nut
- 17. Hex Nut
- 18. Lock Washer
- 19. Cable Clip
- 20. Hex Head Bolt 5/16-18 x 3/4" Lg.
- 21. Hex Jam Nut
- 22. Flat Washer
- 23. Bevel Gear
- 24. Cap
- 25. Hex Jam Nut
- 26. Snap Ring
- 27. Hex Head Bolt 3/8-16 x 2.25" Lg.
- 28. Belleville Washer

FIGURE 11.

INSPECTION AND REPAIR

1. Wash all parts in clean solvent and dry thoroughly.
2. Inspect the nylon bearing and bushings for wear or damage. Replace as necessary.
3. Check for broken teeth, bent shafts and stripped threads. Replace as necessary.

REASSEMBLY AND INSTALLATION

1. Reassemble and install by reversing the removal and disassembly procedure. Apply Cub Cadet multi-purpose grease or equivalent liberally to the gear assembly, bearings and shaft.

STEERING SHAFT FLANGE BEARING REPLACEMENT

1. Remove the cap (Ref. 24), hex nut (Ref. 25) and hex head bolt (Ref. 27) from steering box (Ref. 9).
2. Remove the hex nut and flat washer at the end of the steering shaft. (Ref. 6), remove snap ring (Ref. 26) and pull out the steering shaft from steering box.
3. Remove hex nut and flat washer on end of steering wheel shaft assembly (Ref. 5).
4. Pull steering shaft assembly out of steering box and gear.
5. With the front wheels straight ahead, install the steering assembly. Be sure the pinion gear on the steering shaft is in the center of the pinion gear (Ref. 23). Install hex nut and flat washer.

FRONT AXLE

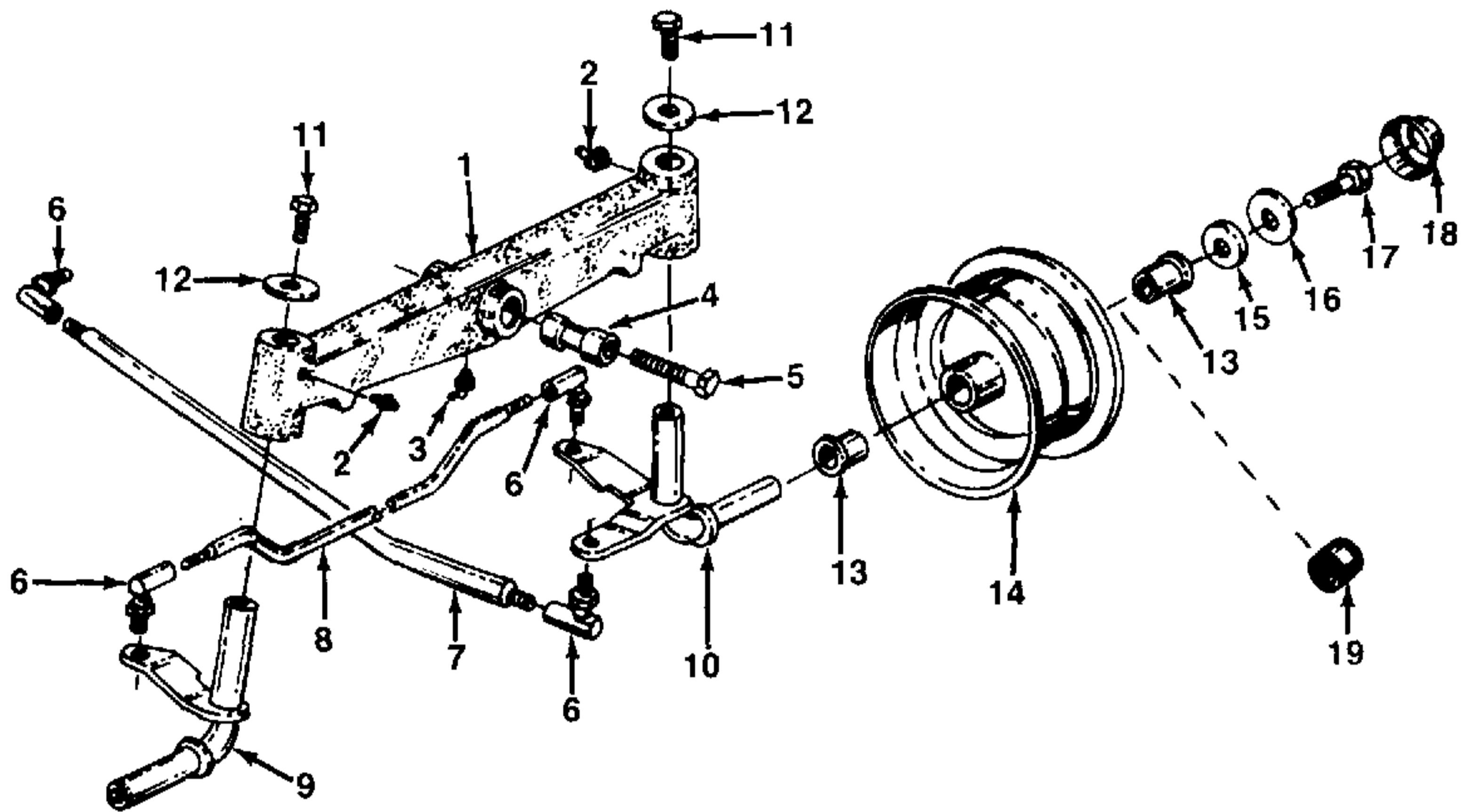

FIGURE 1.

1. Axle, Front Pivot Bar	12. Flat Washer—(2)
2. Grease Fittings—(2)	13. Flange Bushing—(2 Per Wheel) [Serial Number 113,999 and Below]
3. Grease Fitting—(1) 45°	14. Wheel Rim
4. Bushing, Axle Pivot	15. Flat Washer (1 Per Wheel)
5. Bolt, 4" Long	16. Flat Washer (1 Per Wheel)
6. Ball Joints—(4)	17. Bolt (1 Per Wheel 3/4" Long)
7. Drag Link, Steering	18. Hub Cap—(2)
8. Tie Rod, Front Axle	19. Bearing, Ball—(2 Per Wheel) [Serial Number 114,000 and Above]
9. Axle Assembly—R.H.	
10. Axle Assembly—L.H.	
11. Bolts—(2) 3/4" Long	

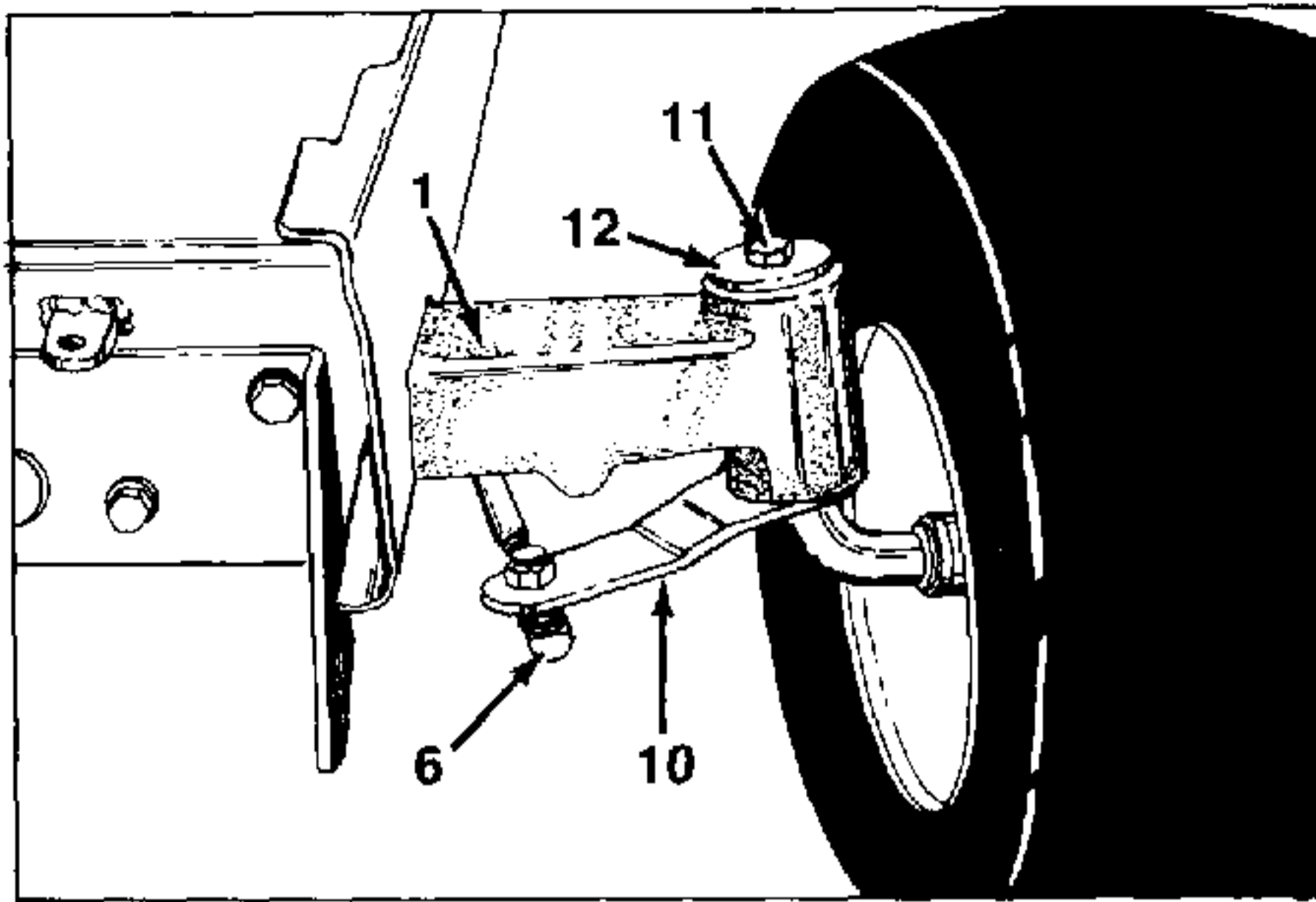

FIGURE 2.

FRONT AXLE DISASSEMBLY

1. Lock the brake. Raise the front of the tractor and support with stands under the frame.
2. Pry off the hub caps (Ref. 18) and remove the wheels (Ref. 14).
3. Remove the tie rod (Ref. 8).
4. Disconnect the drag link (Ref. 7) from the left axle assembly (Ref. 10).
5. Remove the retaining bolt (Ref. 11) and left axle assembly (Ref. 10).
6. Remove the retaining bolt (Ref. 11) and the right axle assembly (Ref. 9). See figure 3.
7. Remove the pivot bolt (Ref. 5) and slide the pivot bar (Ref. 1) out of the frame.

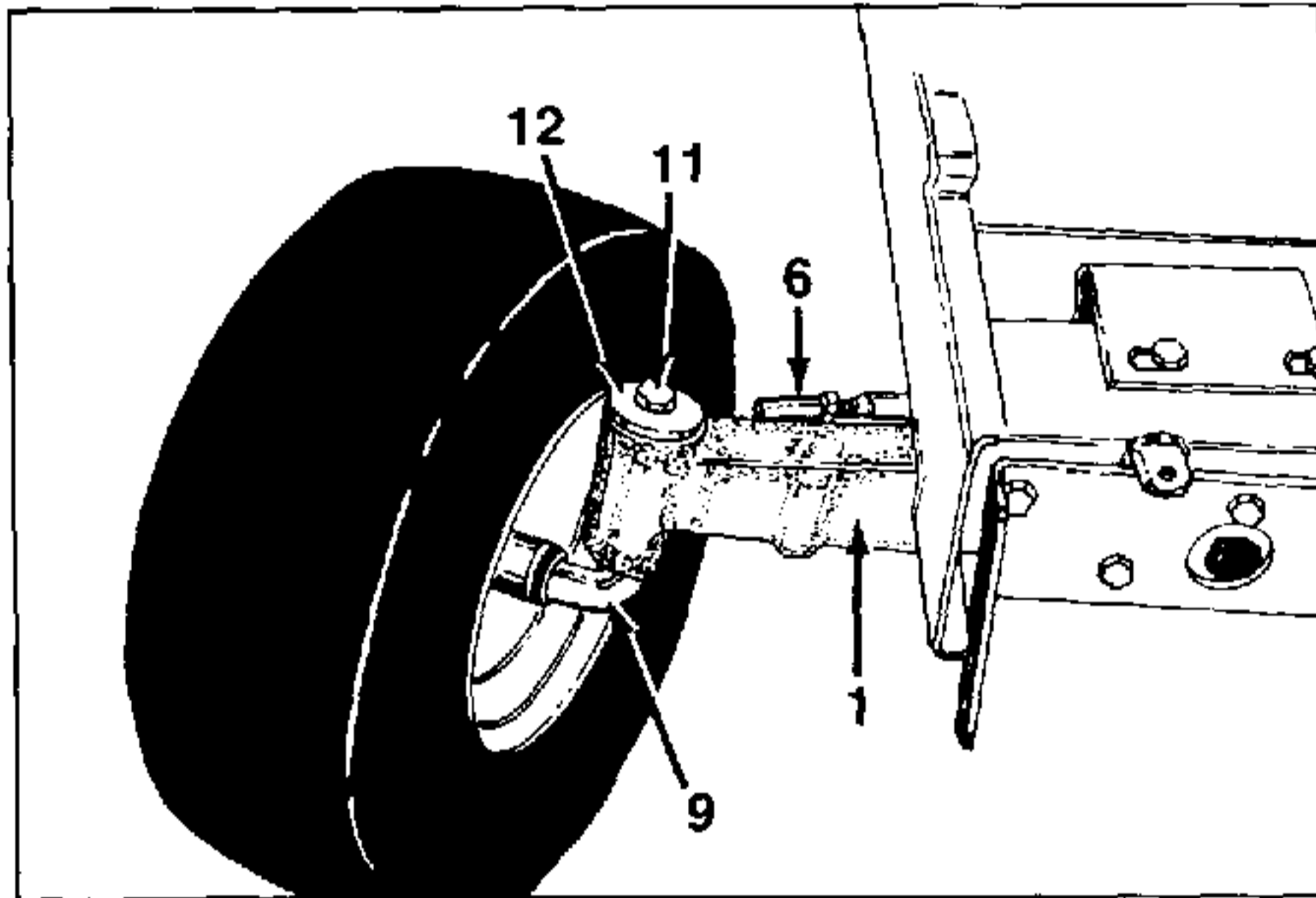

FIGURE 3.

INSPECTION AND REPAIR

1. Clean all parts thoroughly in clean solvent.
2. Inspect all parts for wear, bending or cracking. Replace as needed.
3. The front wheel bushings (Ref. 13) or bearing (Ref. 19) may be removed with a punch and hammer, if worn. Install the new bushings with a press. See figure 1, page 2-7.

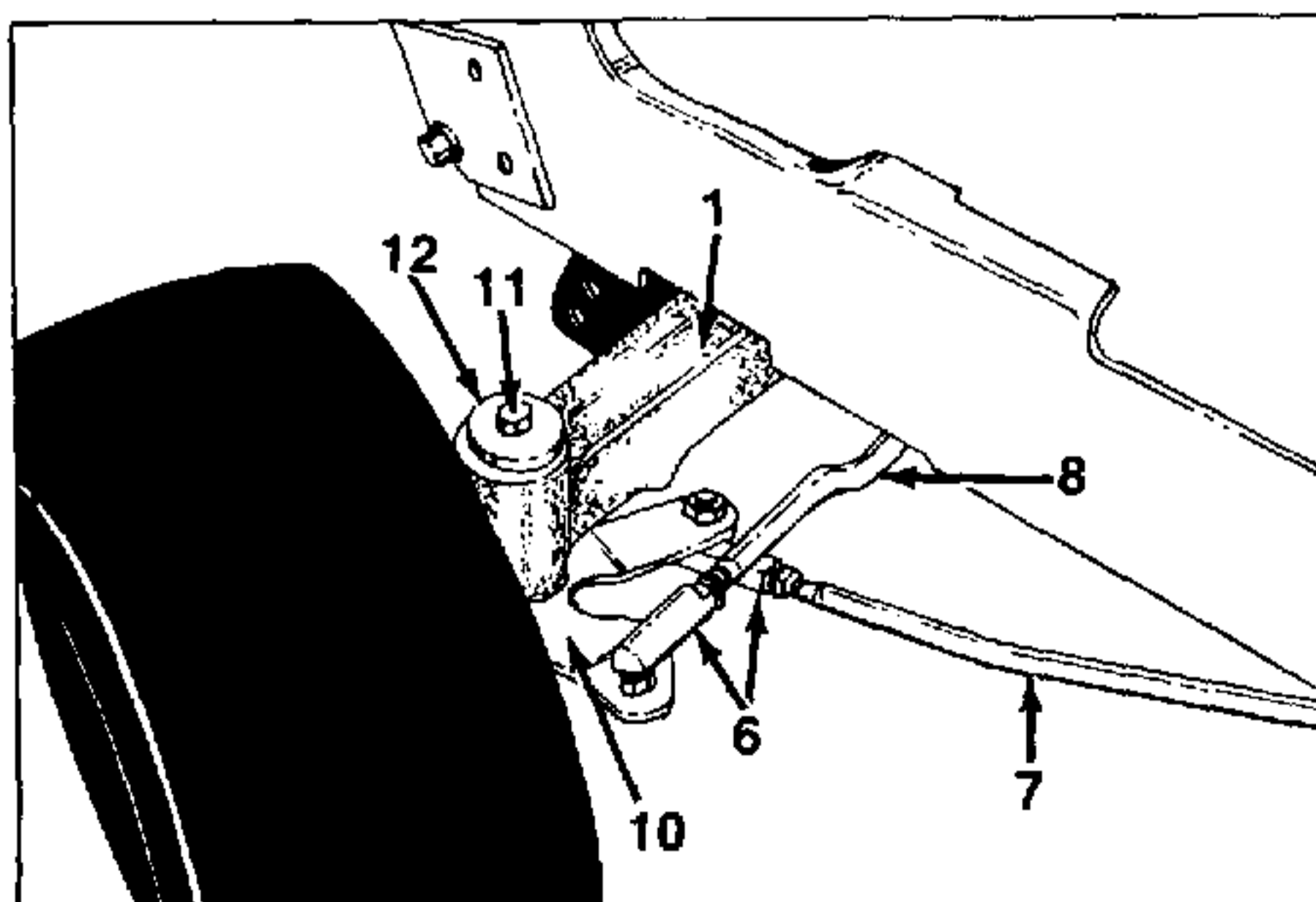

FIGURE 4.

REASSEMBLY

1. Reassemble the pivot bar by reversing the disassembly procedure.
2. Lubricate the axle bushing, spindles and wheels thoroughly with Cub Cadet multi-purpose grease or equivalent.

PIVOT BAR ADJUSTMENT BOLTS

CAUTION: The tractor must be checked every 50 hours of tractor operation for play between the front axle and the pivot bar adjustment bolts. Both adjustment bolt heads must fit against the front axle. If play is discovered, the pivot bar adjustment bolts must be adjusted.

If play is discovered between the front axle and the pivot bar adjustment bolt heads, adjust both bolts as follows: See figure 5.

1. Loosen jam nut 3 to 4 turns or as required.
2. Turn pivot bar adjustment bolt counterclockwise until it hits against the front axle.
3. Tighten jam nut.
4. Repeat the above steps for the other pivot bar adjustment bolt.

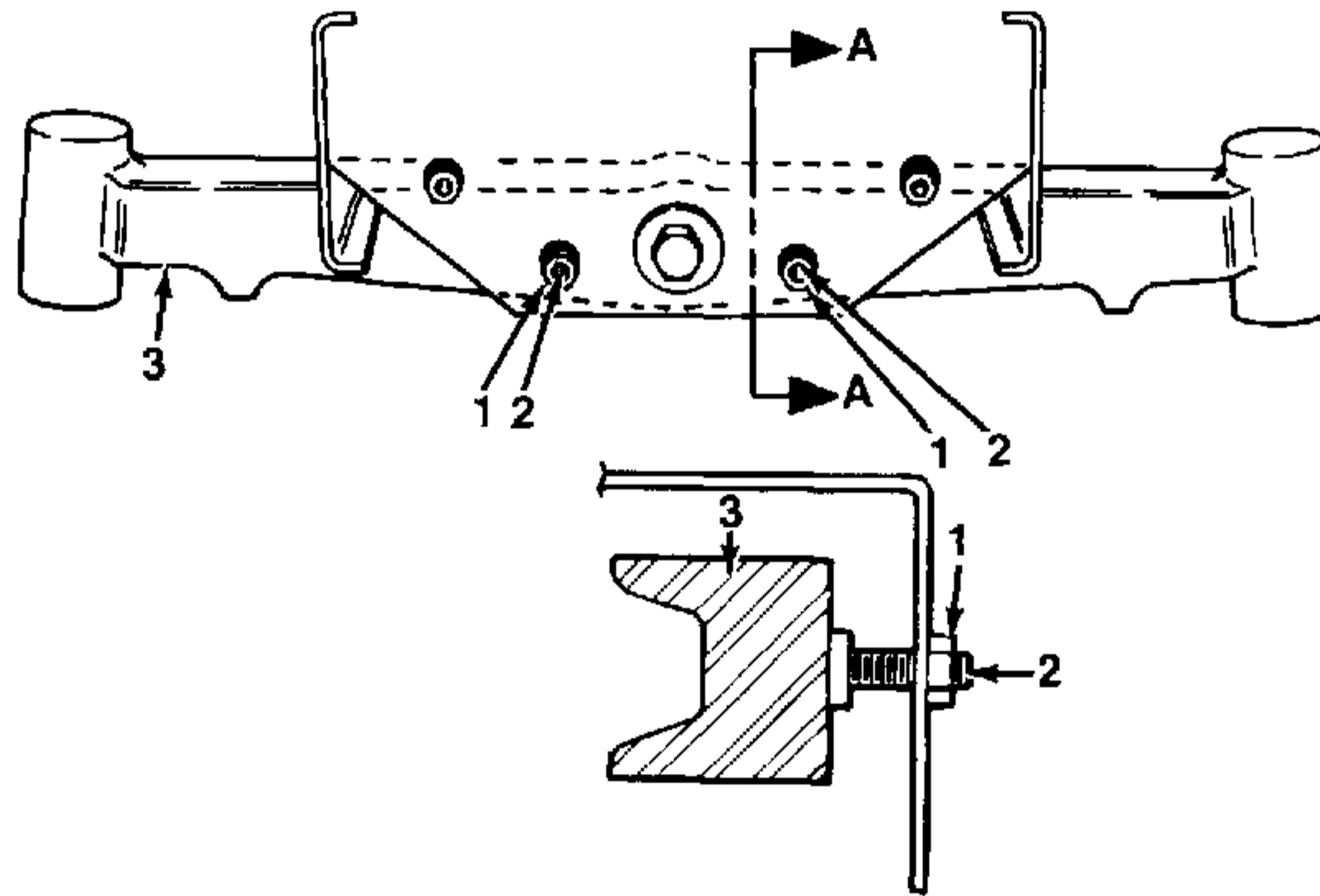

FIGURE 5.

1. Jam Nut
2. Pivot Bar Adjustment Bolts
3. Front Axle

WHEEL ALIGNMENT

The front wheels should toe-in approximately 1/8 inch.

Measure the distances A and B on the front wheels. See figure 6.

NOTE: Dimension B should be approximately 1/8 inch less than dimension A.

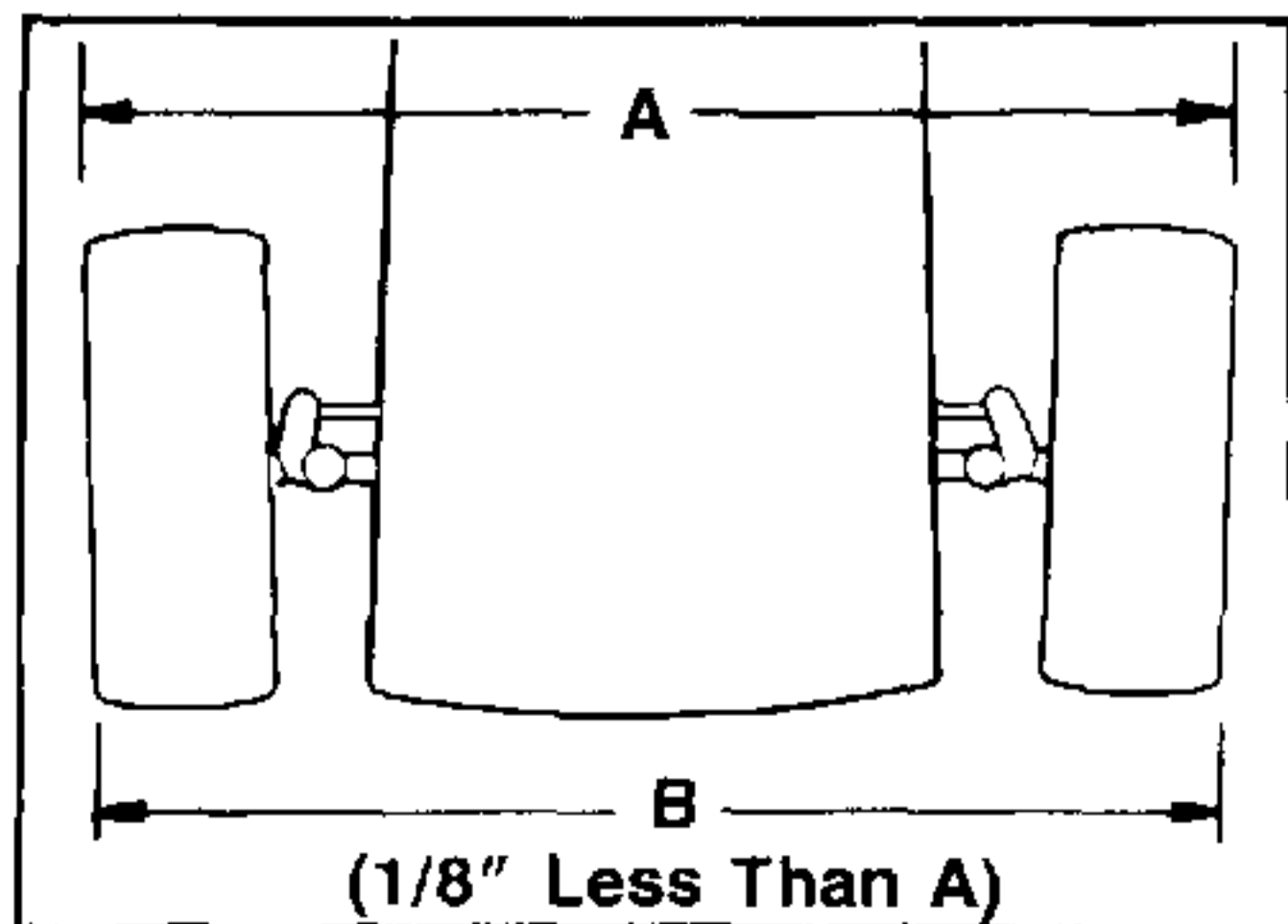

FIGURE 6.

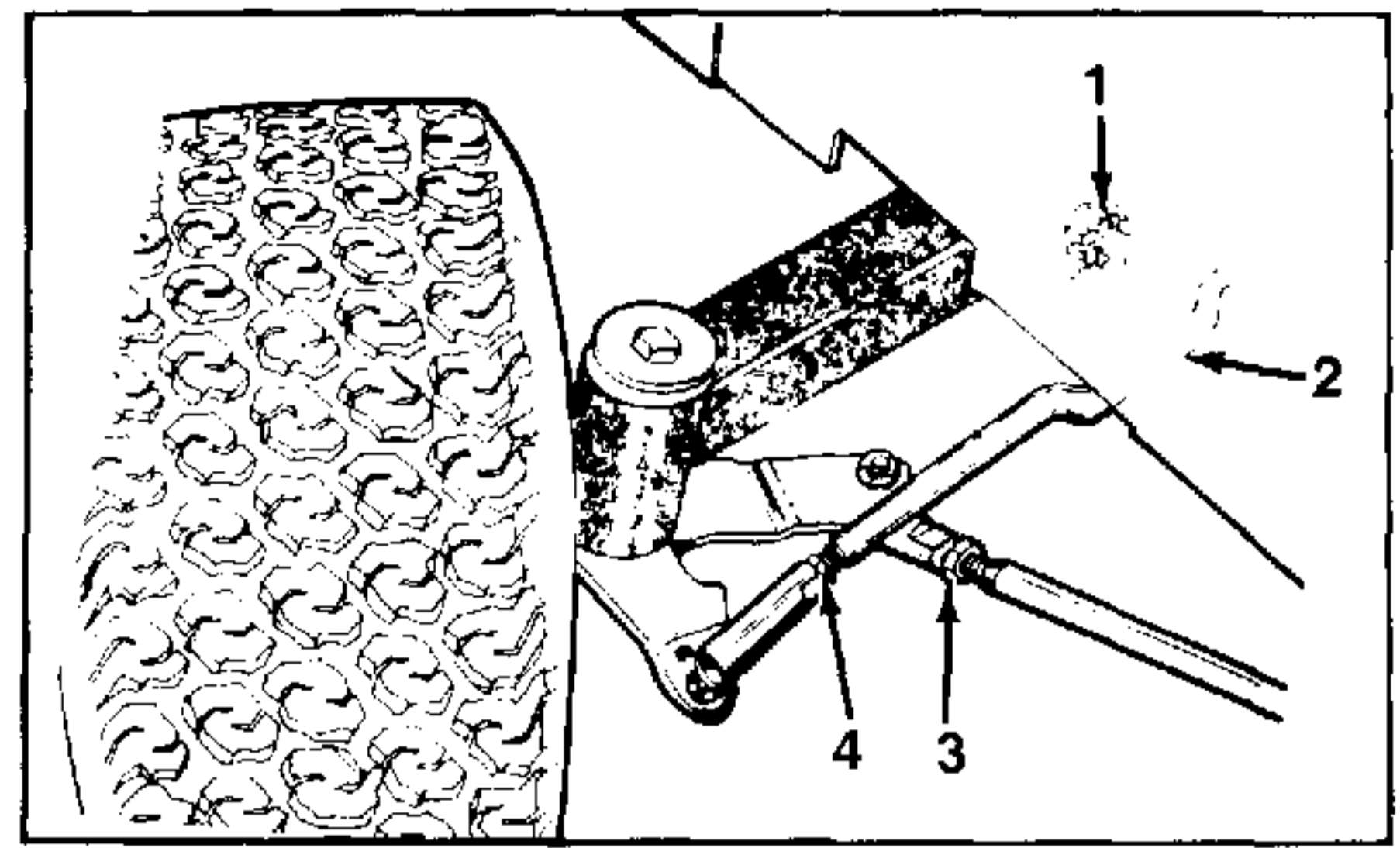

FIGURE 7.—Tie Rod and Drag Link Ball Joints

1. Castle Nut at Pivot Bar
2. Bend in Tie Rod
3. Lock Nut "D"
4. Lock Nut "C"

FRONT WHEEL ADJUSTMENTS

To adjust the toe-in remove one ball joint, loosen lock nuts "C" at the ball joint and turn the tie rod ball joint in or out as required. See figure 7.

NOTE: Tie rod has a bend in the center for clearance of castle nut on pivot bar. Bend must remain down as shown in figure 7.

TURNING RADIUS

CAUTION: Be sure all parts are tightened after completing the following adjustment.

The front wheels should have an equal angle for left and right turns. If adjustment is necessary, remove ball joint and loosen lock nut "D". See figure 7. Turn the drag link ball joint clockwise or counterclockwise as required.

5-SPEED TRANSAXLE

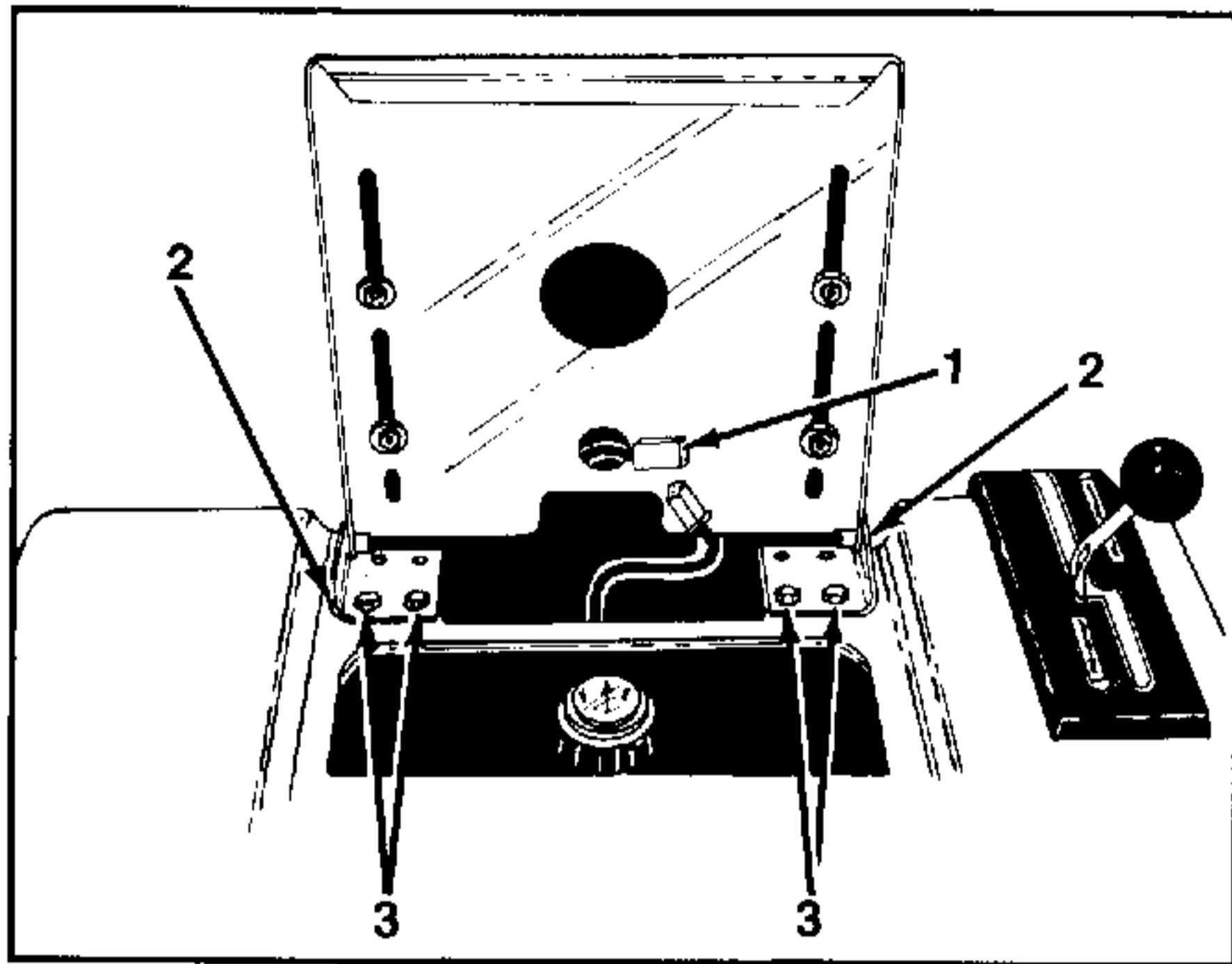

FIGURE 1.

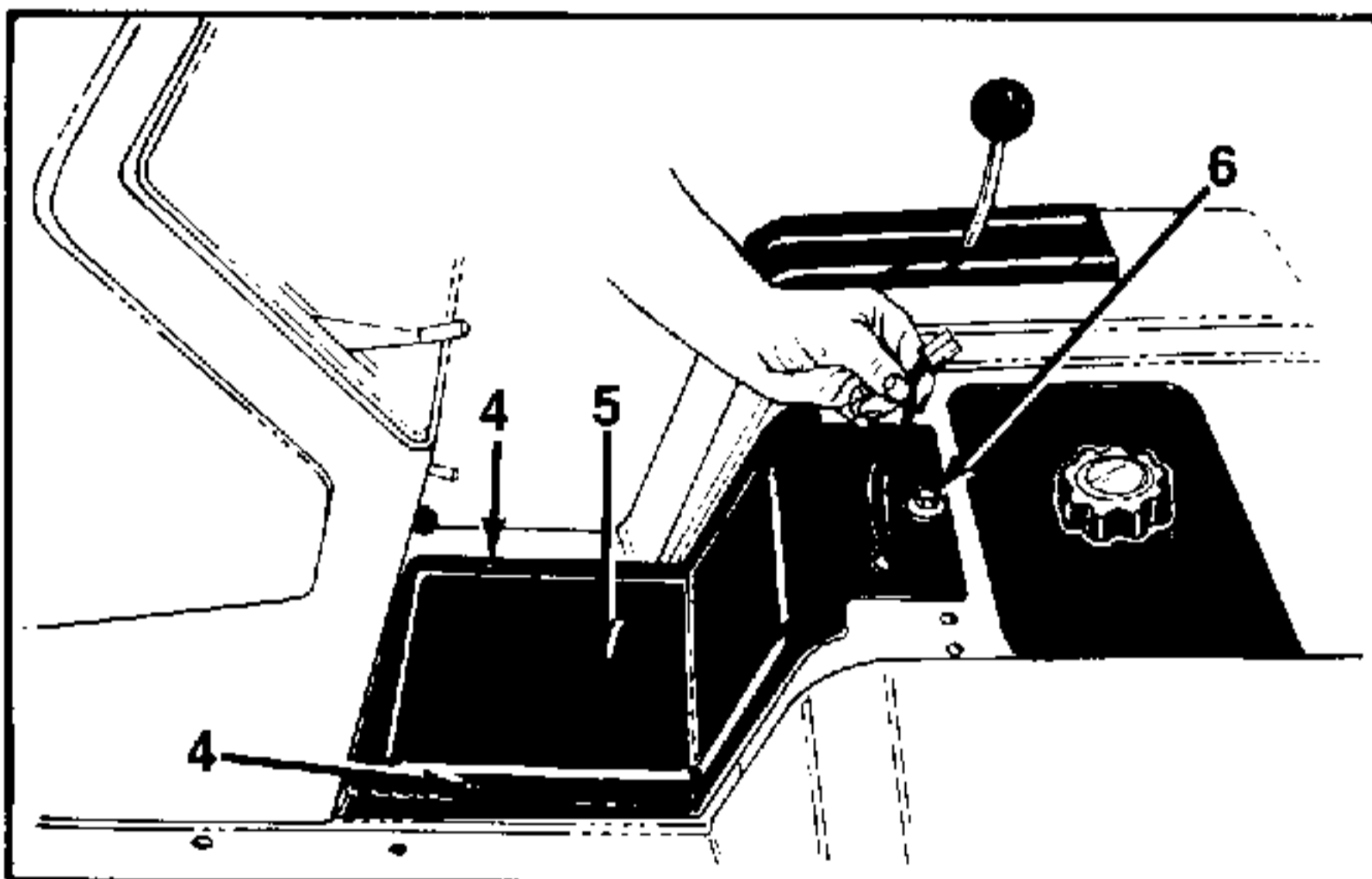

FIGURE 2.

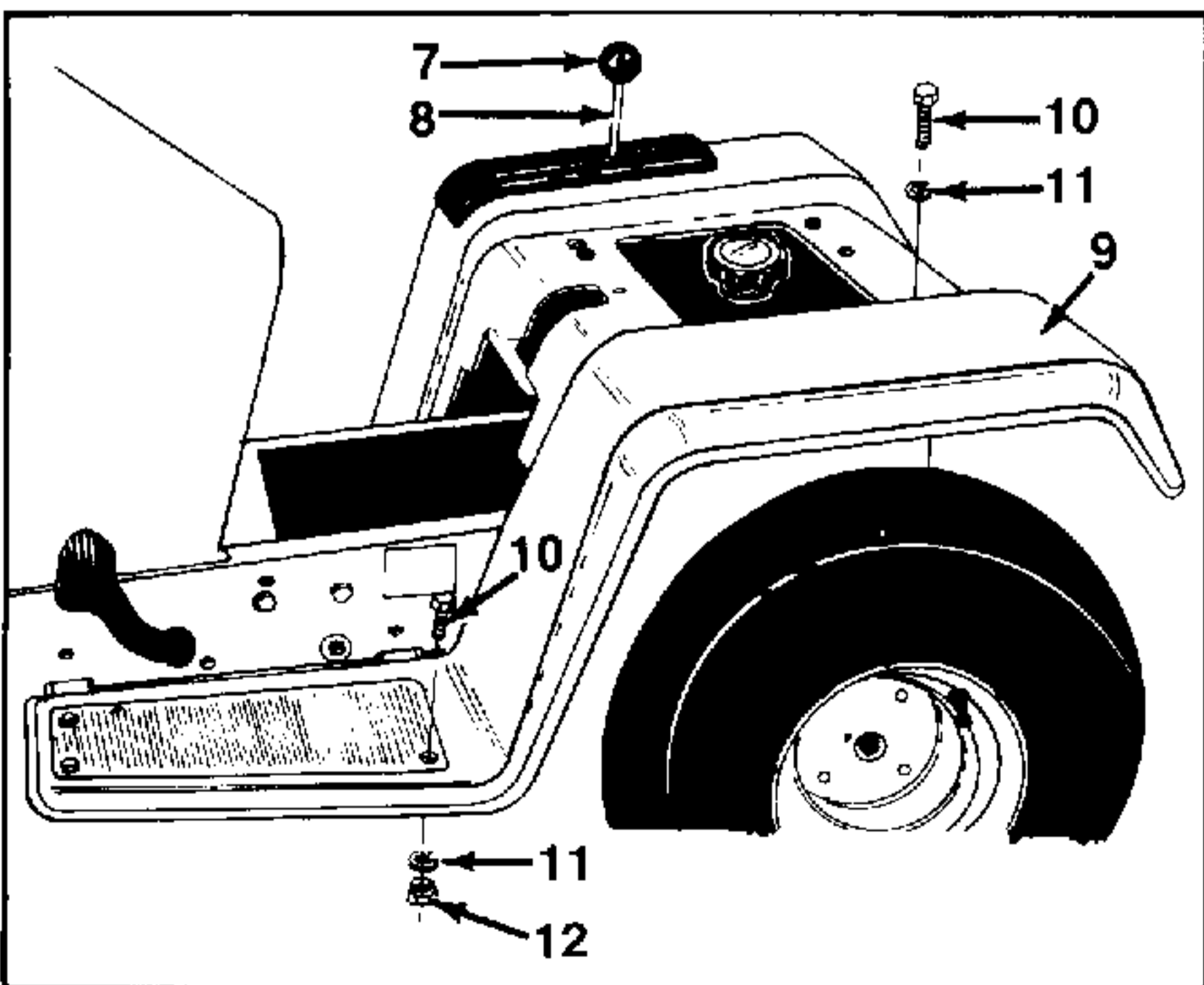

FIGURE 3.

REMOVAL

1. Unplug the seat safety switch (Ref. 1) located under the seat and seat mounting bracket (Ref. 2). See figure 1.
2. Remove the four hex bolts 3/8" x 1" long (Ref. 3). See figure 1. Remove the seat and seat bracket (Ref. 2).

NOTE

Fender shift lever was used on 1985, 1986, 1987 and 1988 units, except for 1015 and 1020 units. All others have shift lever in the dash. See figure 3A.

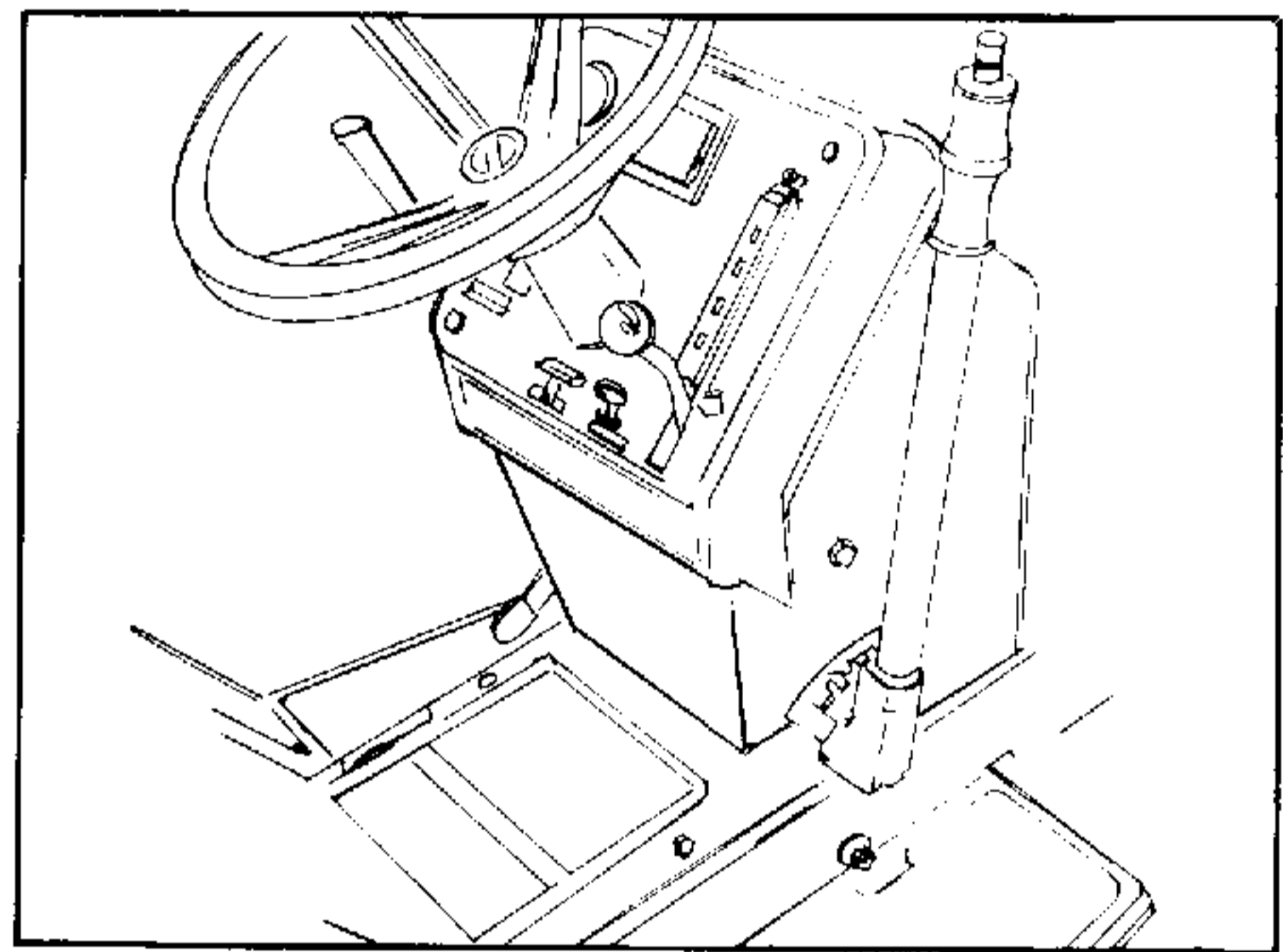

FIGURE 3A.

3. Remove the center cover (Ref. 5) by removing two screws (Ref. 4) and one hex bolt and flat washer (Ref. 6). See figure 2.

- | |
|--|
| <ol style="list-style-type: none"> 1. Seat Safety Switch 2. Seat and Seat Bracket 3. Hex Bolts 3/8" x 1" Long 4. Phillips Head Screws 5. Center Cover 6. Hex Bolt 3/8" x 1" Long and Flat Washer |
|--|

4. Position the shift lever to neutral. Remove the speed ratio gear knob (Ref. 7), from gear lever (Ref. 8). See figure 3.
5. Remove the fender assembly (Ref. 9), by removing two hex bolts (Ref. 10) and lock washers (Ref. 11) at rear of fender.
6. Remove six more bolts (Ref. 10), lock washers (Ref. 11) and hex nuts (Ref. 12). See figure 3. There are three on each side of fender assembly at running boards.

NOTE: The LH and RH rear deck support brackets are assembled to the tractor with the front two bolts at each running board. Note position for reinstallation.

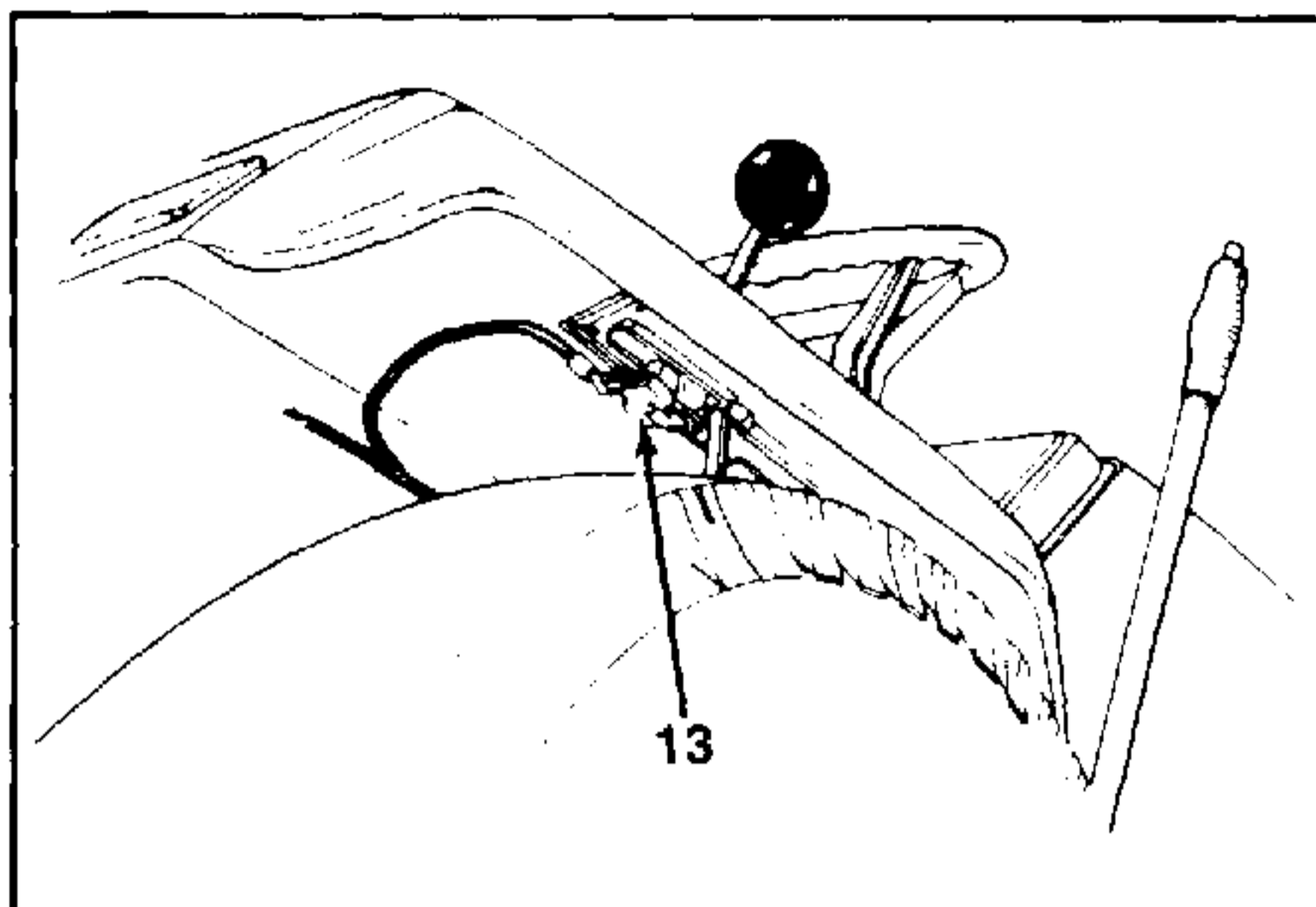

FIGURE 4.

7. With the fenders loose and raised, remove the neutral start switch (Ref. 13) and bracket located under the fender at the shift quadrant. See figure 4. Remove the fender assembly.

NOTE

1989 units have the battery under the seat. Refer to page 1-19 of this manual.

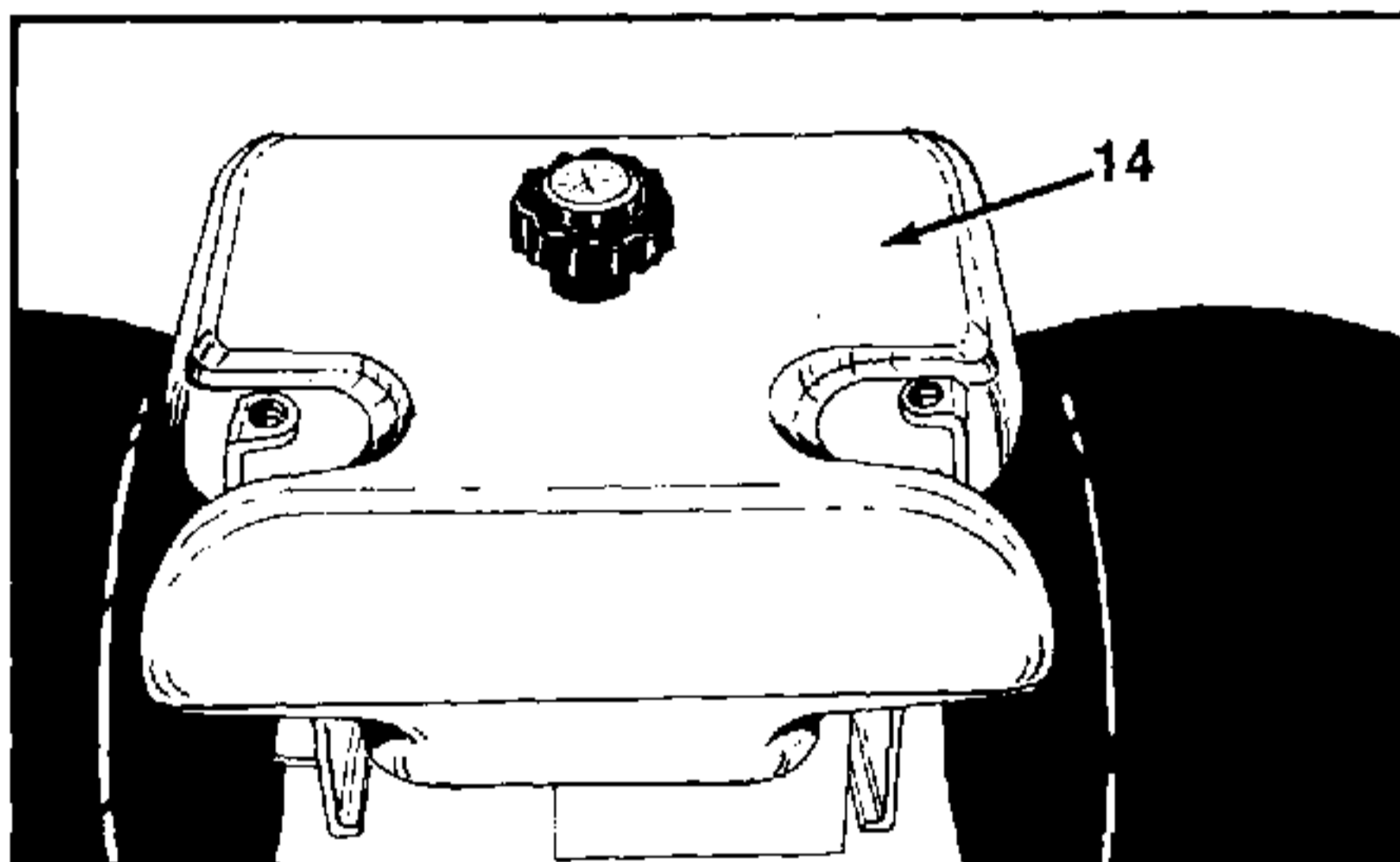

FIGURE 5.

8. Disconnect the fuel line at fuel tank (Ref. 14).
9. Lift out the fuel tank (Ref. 14). See figure 5.

- | |
|---------------------------|
| 7. Speed Ratio Gear Knob |
| 8. Speed Ratio Gear Lever |
| 9. Fender Assembly |
| 10. Hex Bolts |
| 11. Lock Washers |
| 12. Hex Nuts |
| 13. Neutral Start Switch |
| 14. Fuel Tank |
| 15. Rubber Support Strap |

NOTE: During reassembly, be especially cautious of wire harness routing to prevent pinching of the wires.

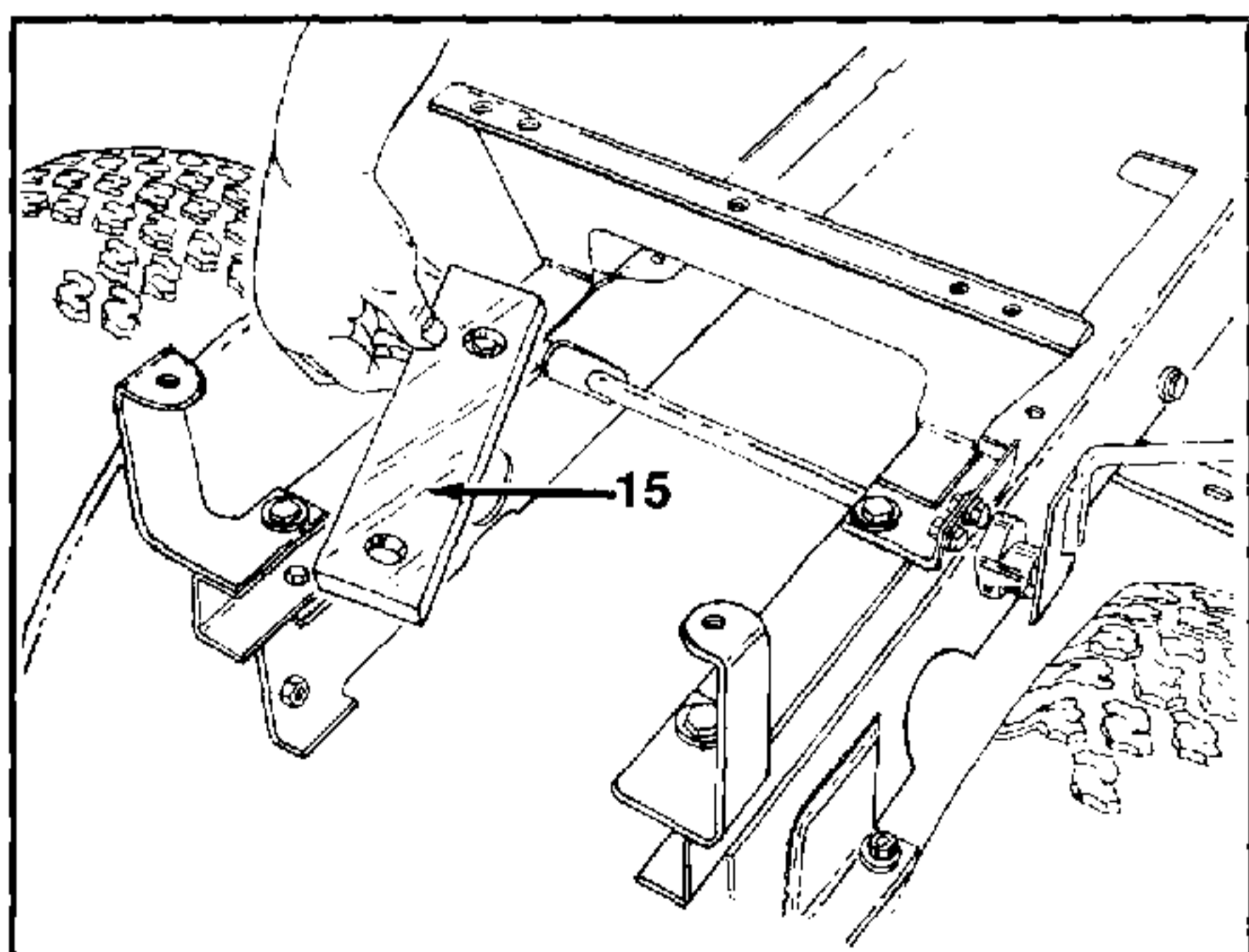

FIGURE 6.

10. Remove the two rubber support straps (Ref. 15), just sitting under fuel tank and on top of fender mount brackets. See figure 6.

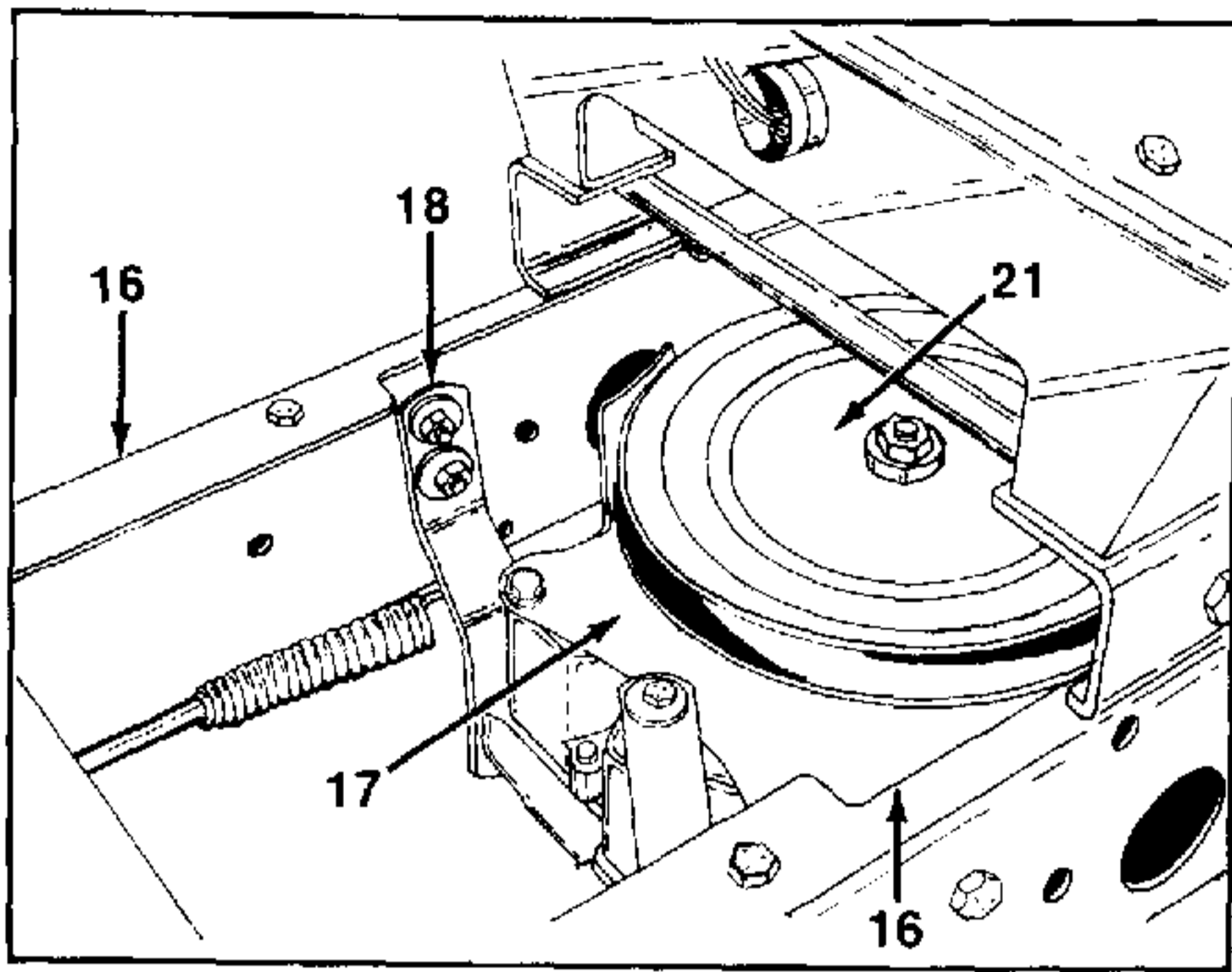

FIGURE 7.

11. Remove the two bolts and washers securing the belt keeper (Ref. 17) to the top front of the transaxle housing. Depress clutch and brake pedal, and engage parking brake handle. See figures 7 and 8.

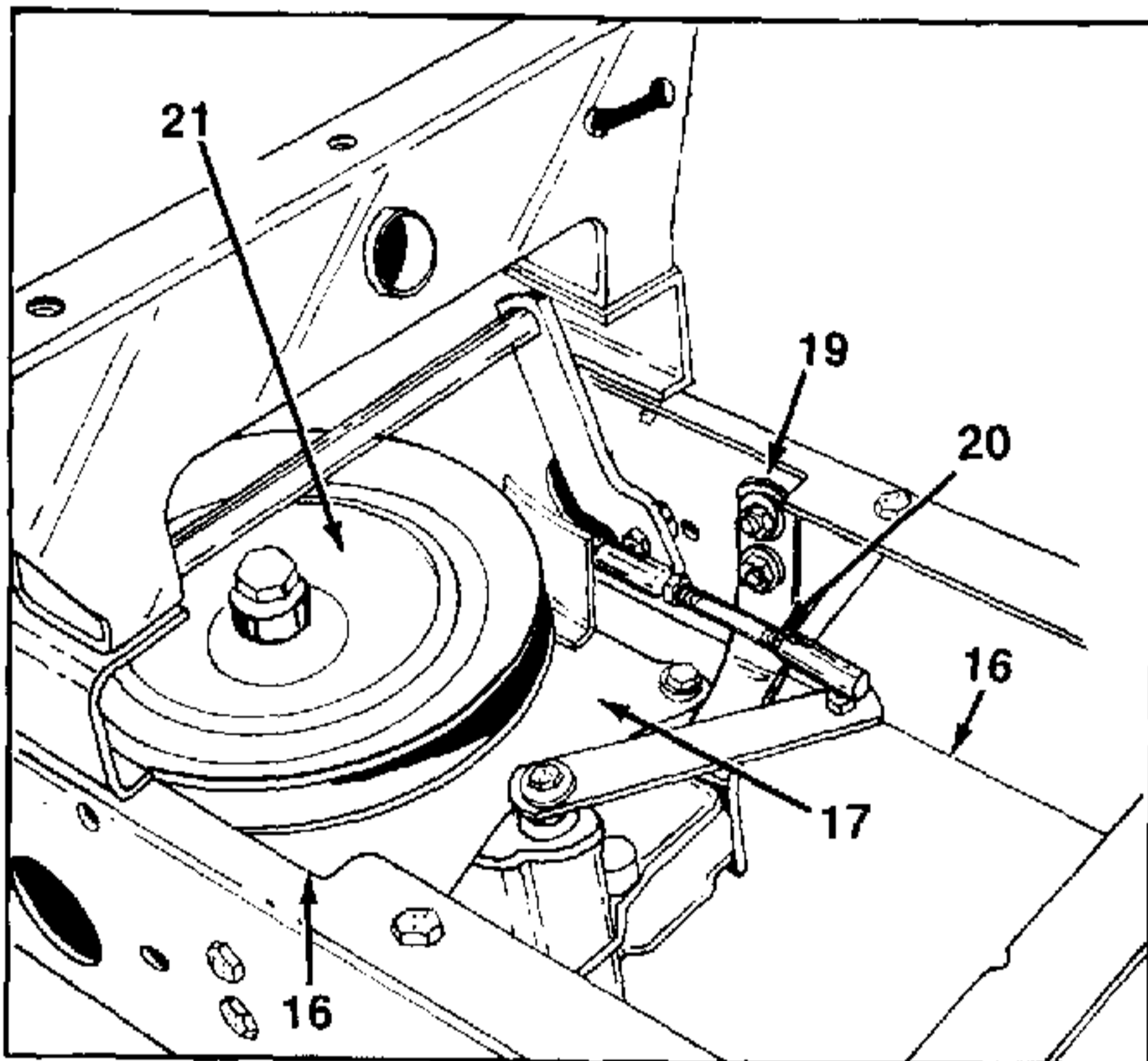

FIGURE 8.

12. Disconnect shift linkage (Ref. 20) at transaxle. See figure 8.
13. Remove the fixed idler pulley (Ref. 22) from under tractor, this will allow you to remove the belt (Ref. 16) from the transaxle pulley (Ref. 21). See figures 7, 8 and 9.
14. Remove the transaxle support straps (Ref. 18 and Ref. 19). See figures 7 and 8.

NOTE: Upon reassembly of support straps (Ref. 18 and Ref. 19) the short end must be assembled to the frame and the long end assembled to the transmission, to prevent brake spring interference.

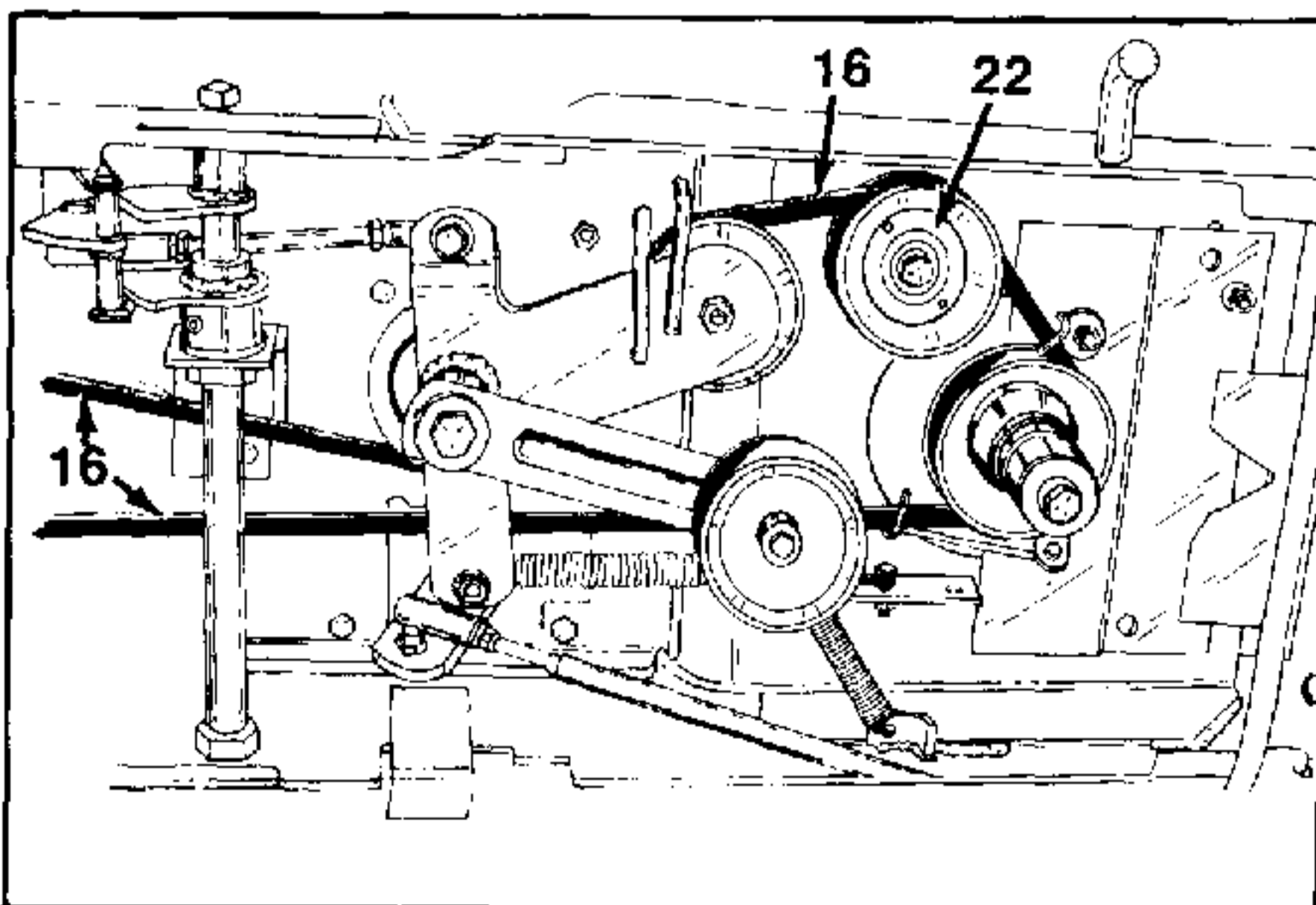

FIGURE 9.

15. Disengage parking brake lever. Disconnect brake rod tension spring (Ref. 26) from brake lever. See figure 11.

- | |
|------------------------------|
| 16. Drive Belt |
| 17. Belt Keeper |
| 18. Right Hand Support Strap |
| 19. Left Hand Support Strap |
| 20. Shift Linkage |
| 21. Transaxle Pulley |
| 22. Fixed Idler Pulley |

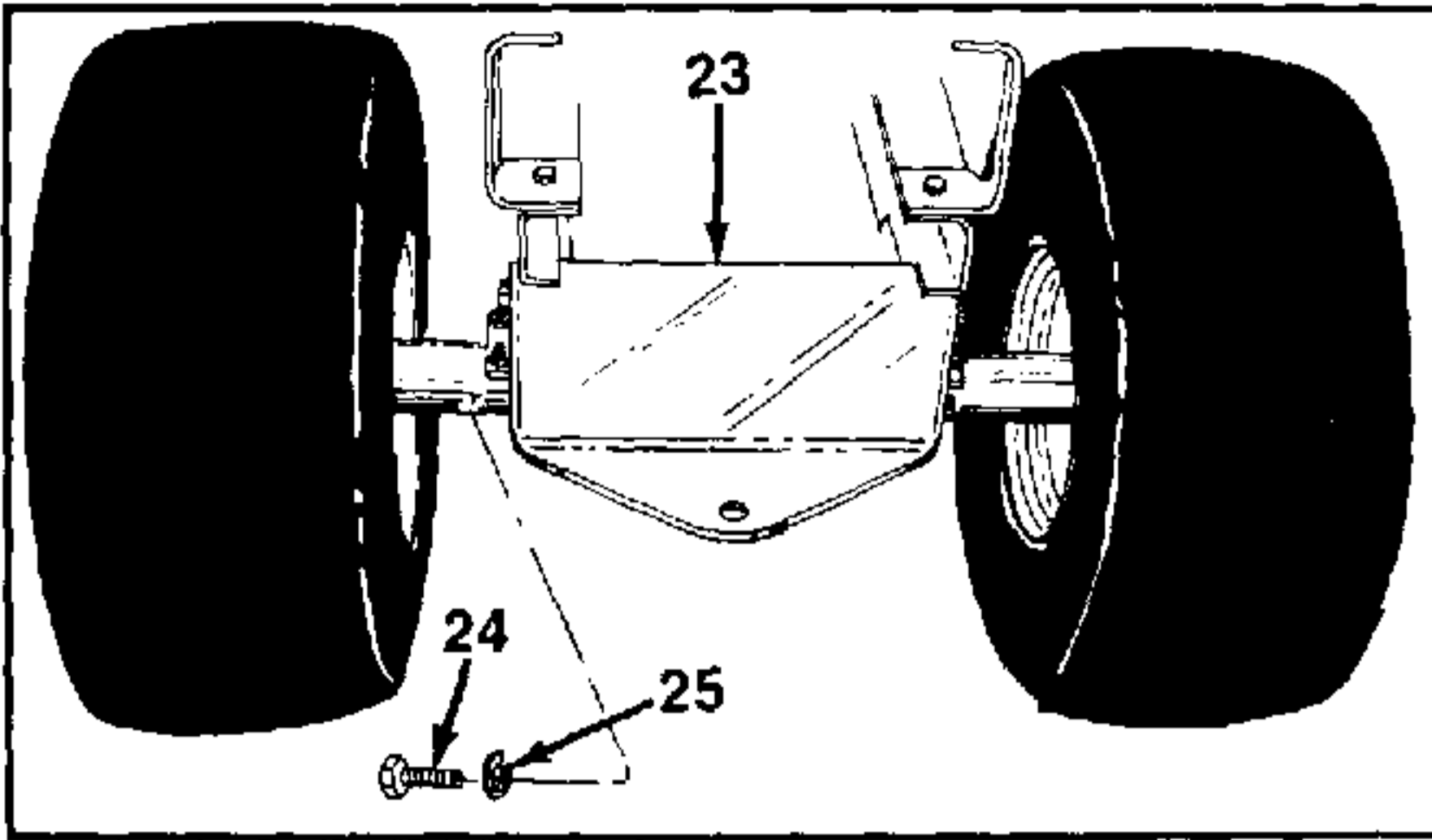

FIGURE 10.

16. Remove four hex bolts (Ref. 24) and lock washers (Ref. 25), which hold the draw bar hitch plate (Ref. 23) to the chassis. See figure 10.

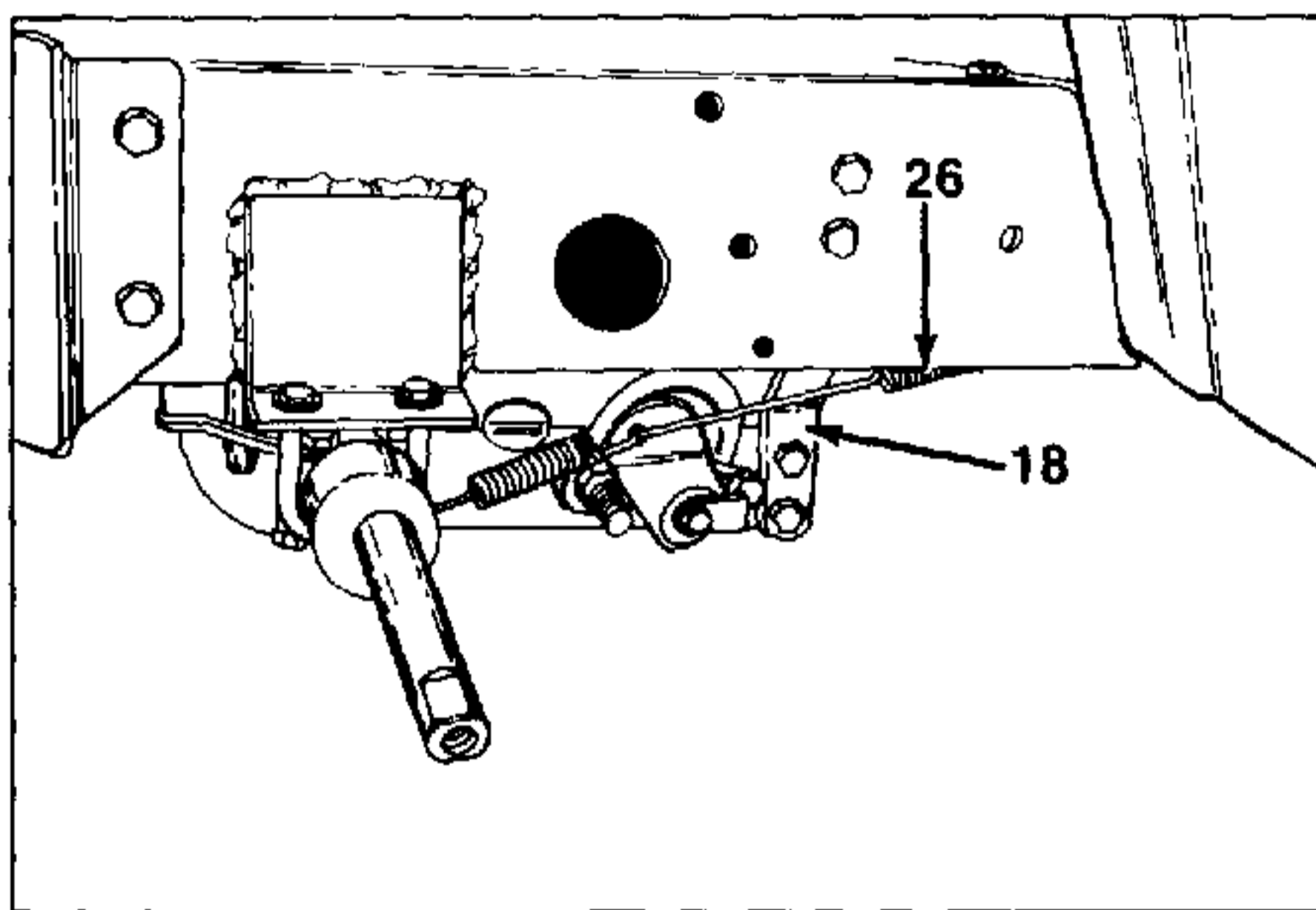

FIGURE 11.

NOTE: Wheel shown removed in figure 10 for clarity only.

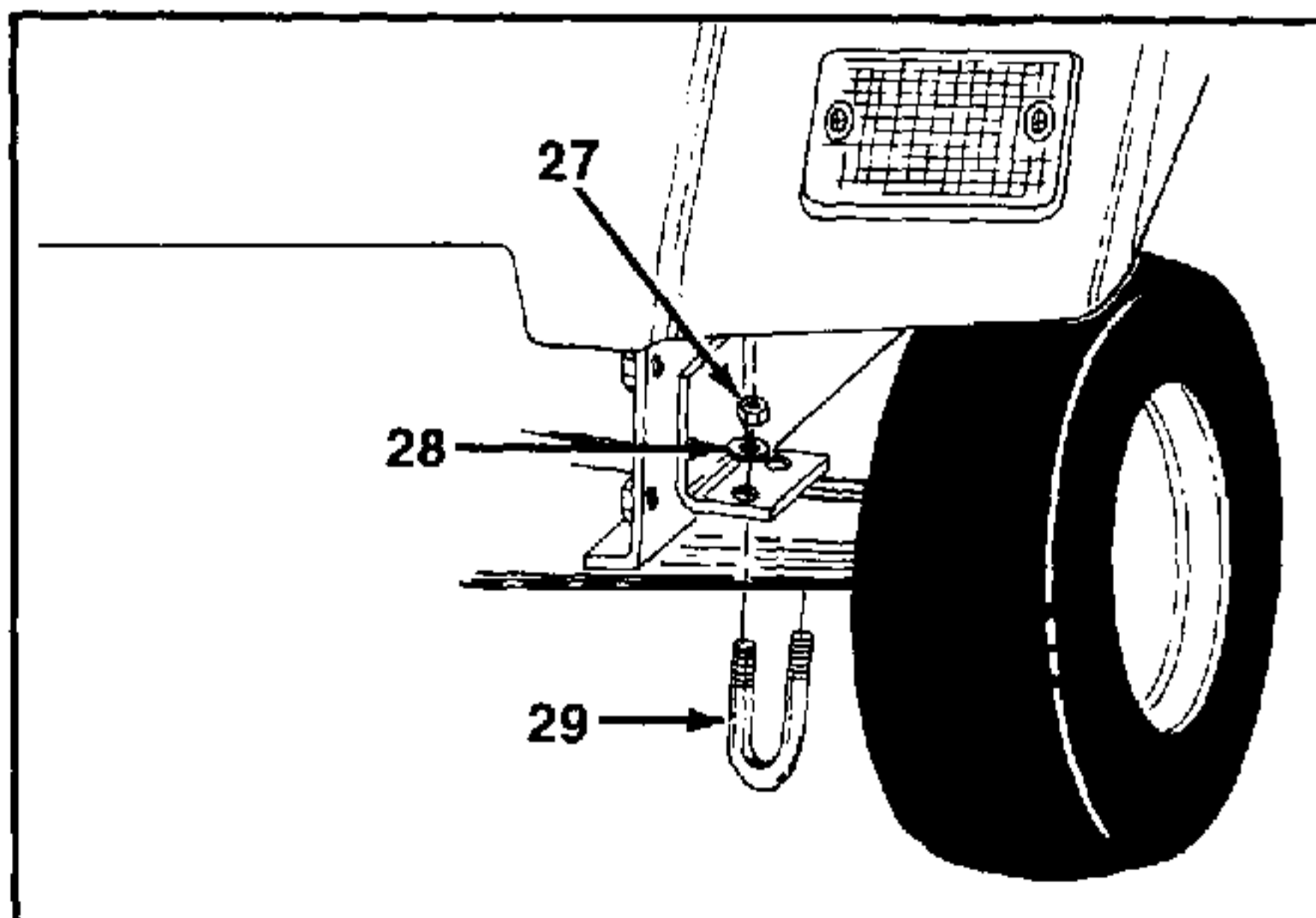

FIGURE 12.

17. Remove the hex nuts (Ref. 27) and lock washers (Ref. 28) from "U"-bolts (Ref. 29). See figure 12.
18. Now the transaxle and rear wheels are ready to roll out from under the rear of chassis.
19. Remove the rear wheels and proceed with disassembly and inspection of transaxle.

- | |
|-------------------------------|
| 23. Draw Bar Plate |
| 24. Hex Bolt 3/8" x 3/4" Long |
| 25. Lock Washer 3/8" I.D. |
| 26. Brake Rod Tension Spring |
| 27. Hex Nut |
| 28. Lock Washer |
| 29. "U"-Bolt |

20. Remove the transaxle pulley (Ref. 21) by removing hex nut and washer. See figure 8 on page 2-12.

5-SPEED TRANSAXLE

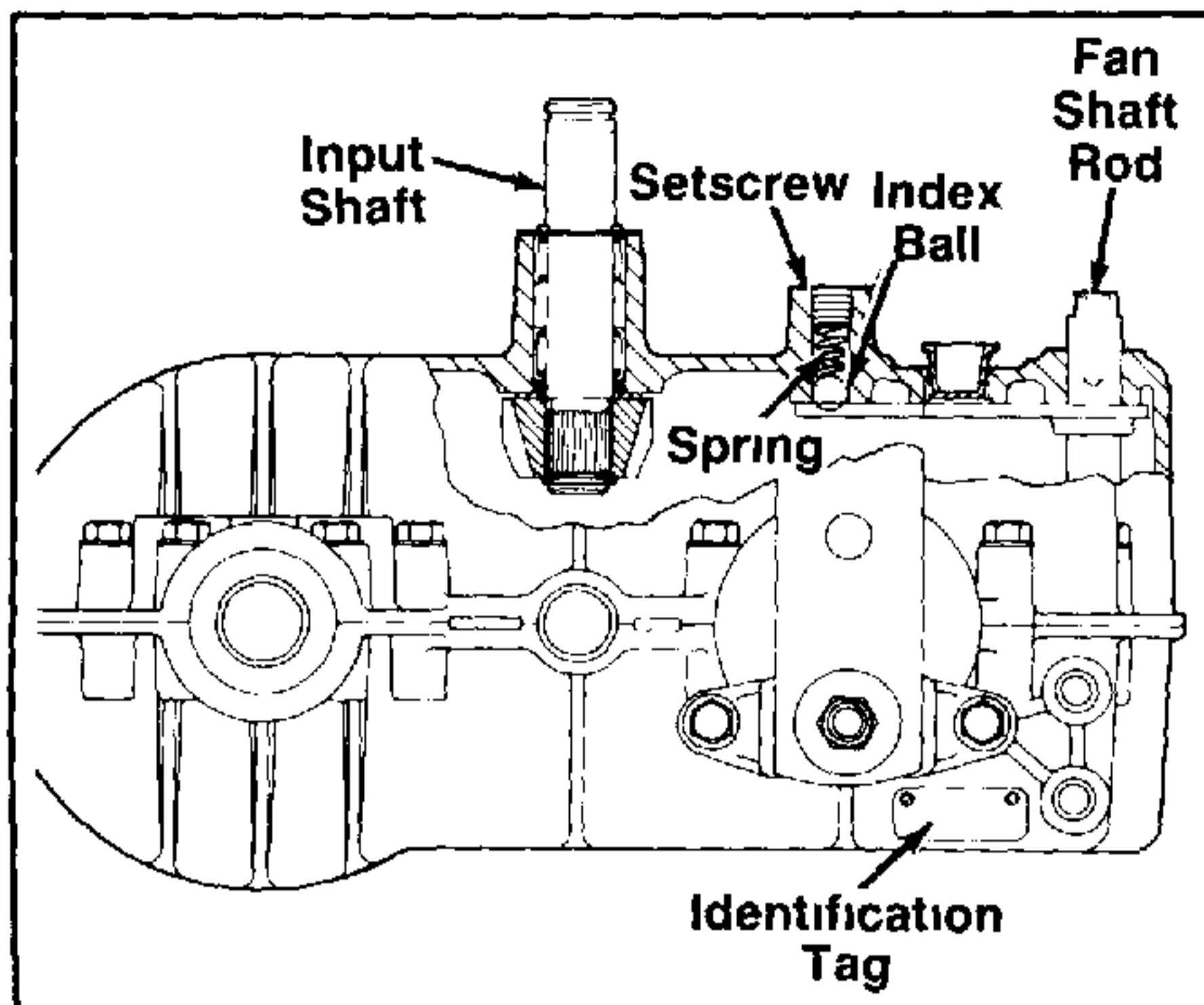

FIGURE 13

IDENTIFICATION

The unit contains an aluminum tag showing the model number. See figure 13.

PRE-DISASSEMBLY

- 1 Clean outside surface of transaxle.
- 2 Remove setscrew, spring, and index ball. See figure 13.

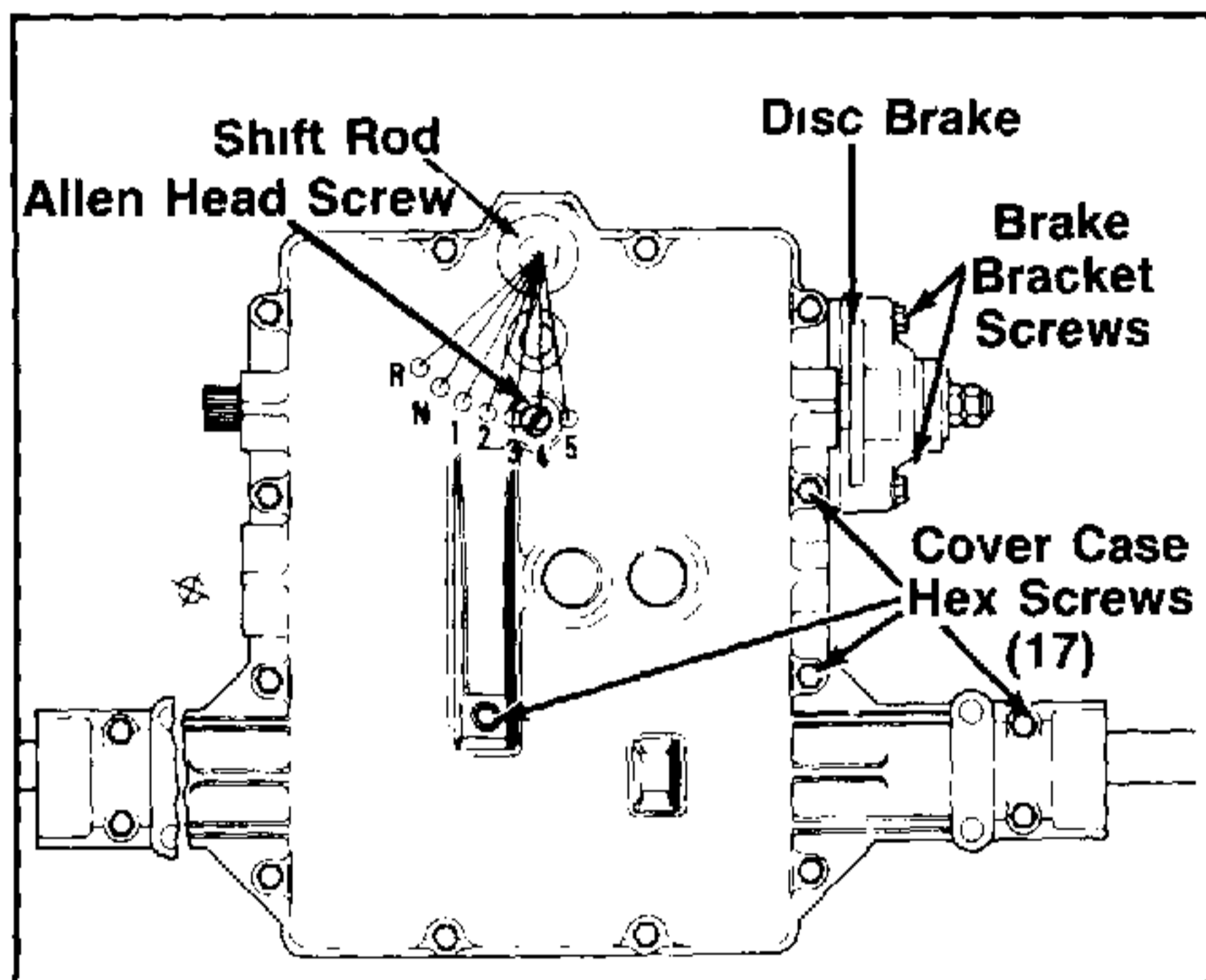

FIGURE 14

DISASSEMBLY

- 1 Remove (17) hex screws that hold cover to case.
- 2 Push shift lever rod in while pulling cover off of case. Shifting assembly may temporarily remain in case. Remove cover.

NOTE: Remove grease from the unit as parts are removed.

- 3 Remove two brake bracket screws, and remove brake assembly. See figure 14.

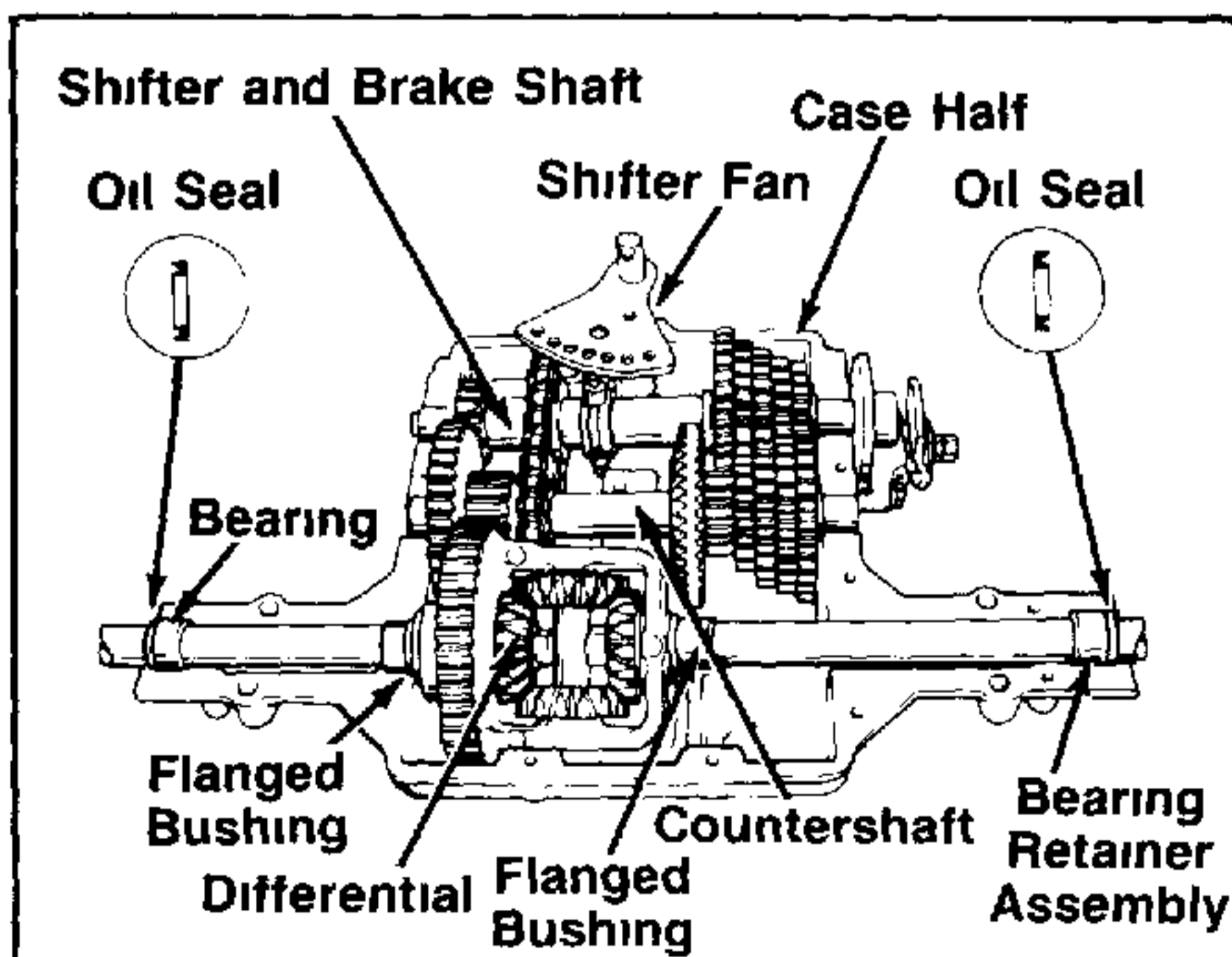

FIGURE 15

NOTE: Prior to removal of gear shaft assemblies from the case, the shifter fan may be removed. It will be difficult to keep parts from falling off the assemblies. Note position of parts before removal.

- 4 Remove gear and shaft assemblies from case half by lifting the two shafts out of the bearing supports, taking care not to disturb drive chain relationship with hubs on sprockets. See figure 15.

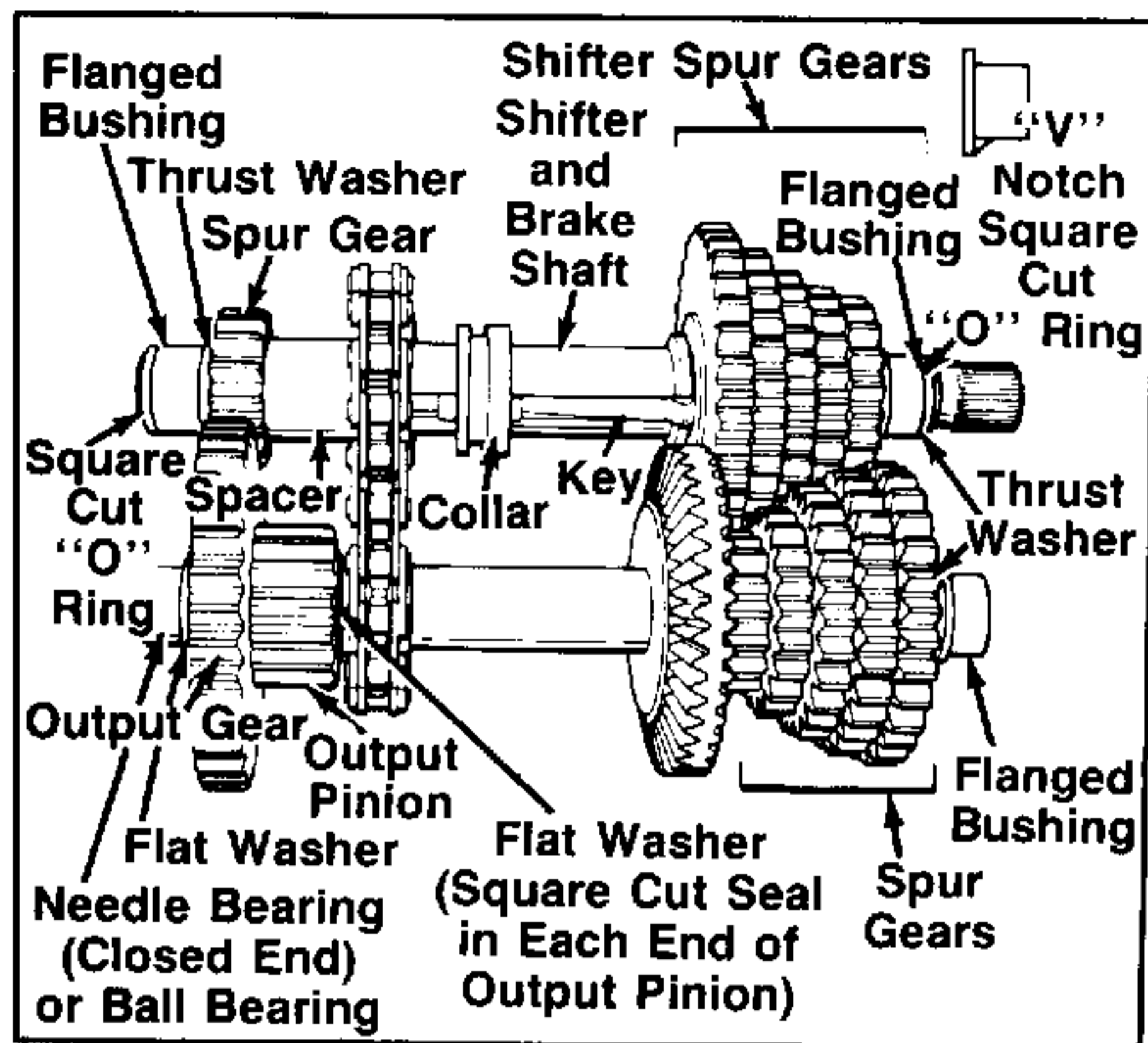

FIGURE 16.

NOTE: Before disassembly, observe how "V" notches on the flanged bushings fit into recess "V" of case. See figure 16.

NOTE: The square cut black rubber "O" ring, acts as a lubrication seal.

- Remove the needle bearing (closed end) flat washers (2), output gear and output pinion, and 3 square cut seals from the countershaft. (2 seals in output pinion—1 in needle bearing cap). "O" rings in countershaft are larger than those on brake shaft ends. Always replace with new seals whenever removed. See figure 16.

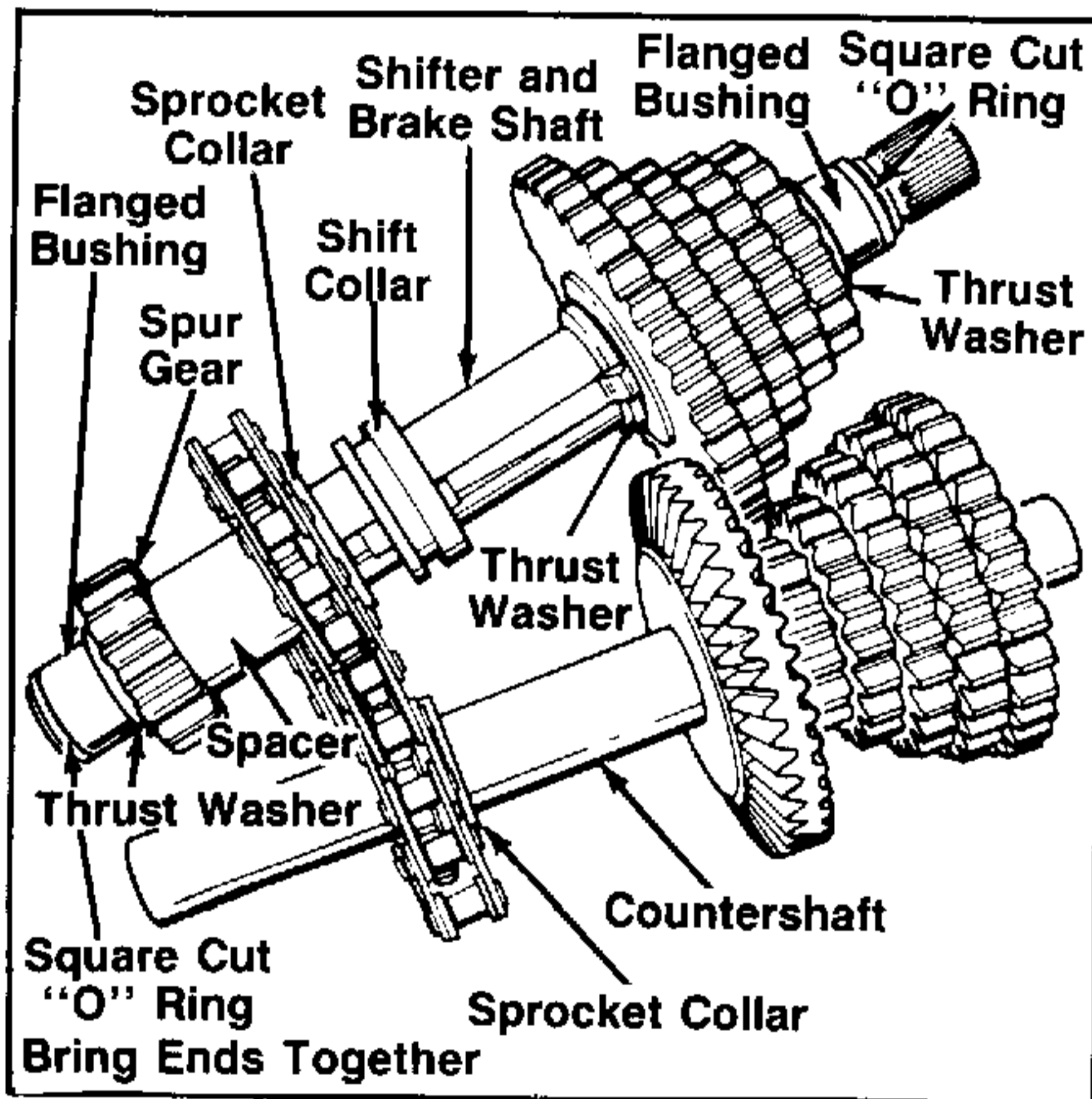

FIGURE 17.

- Angle the shifter and brake shaft and countershaft chain sprocket ends toward each other. Note the collar on the sprockets face the bevel gear. Remove chain. See figure 17.

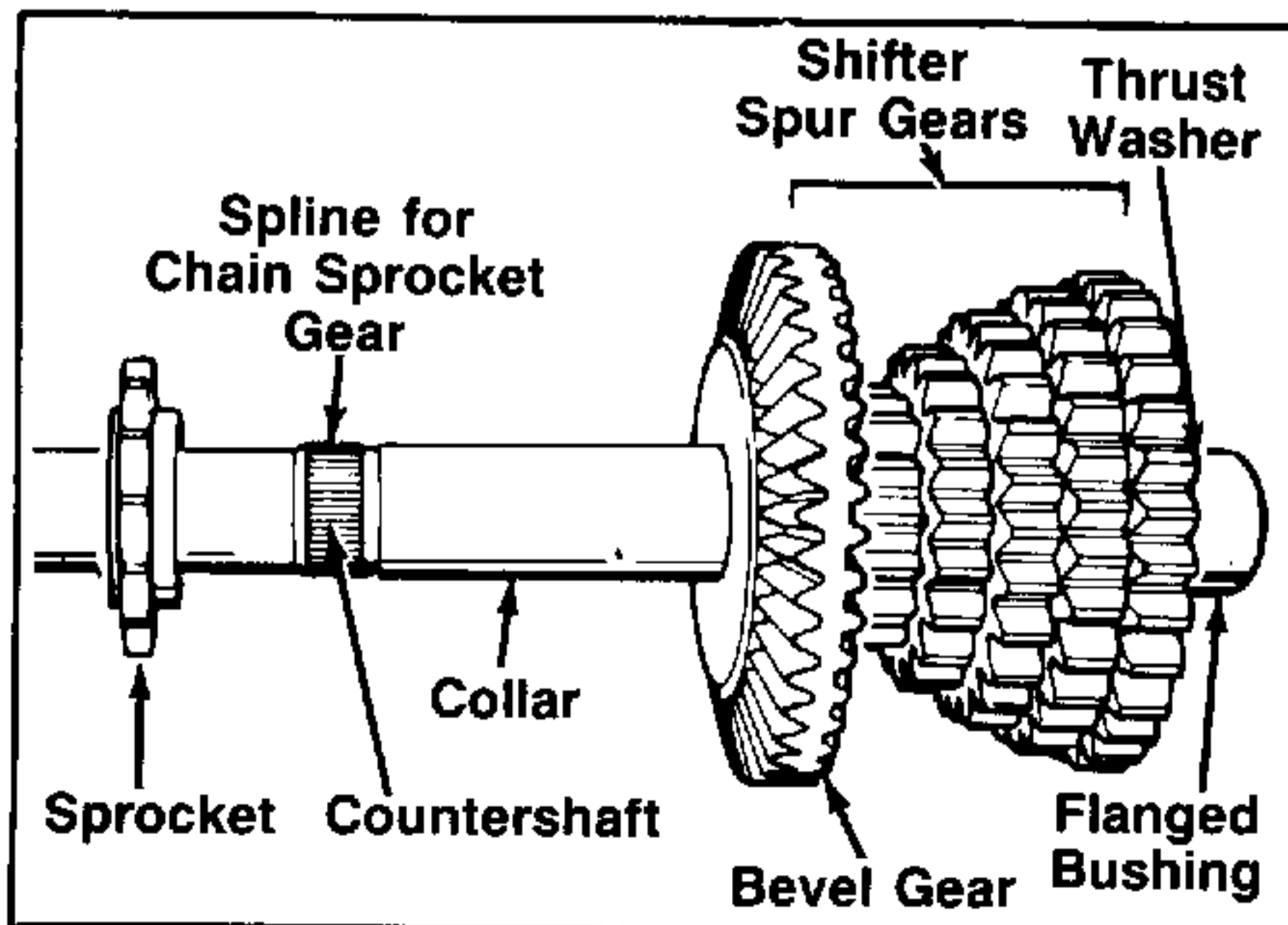

FIGURE 18.

- Remove the sprocket, bevel gear, spur gears, thrust washer, and flanged bushing. The spur gears are splined to the countershaft. See figure 18. **Note the position of the bevel gear for re-installation purposes.**

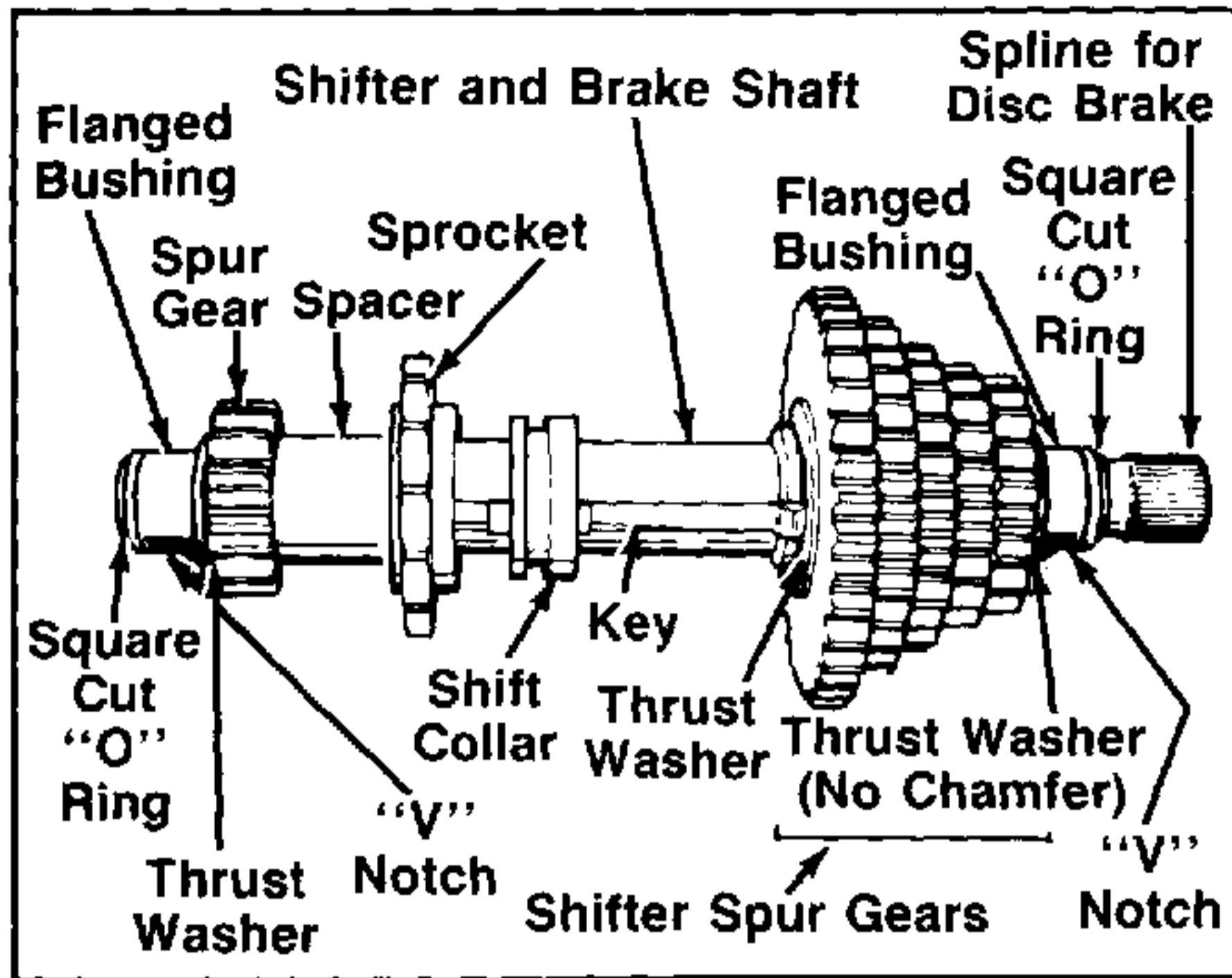

FIGURE 19.

8. Remove the square cut seals (2) and flanged bushings (2), thrust washers (2) on shaft ends, spur gear, spacer, sprocket, shift collar with keys, thrust washers and shifter spur gears. See figure 19.

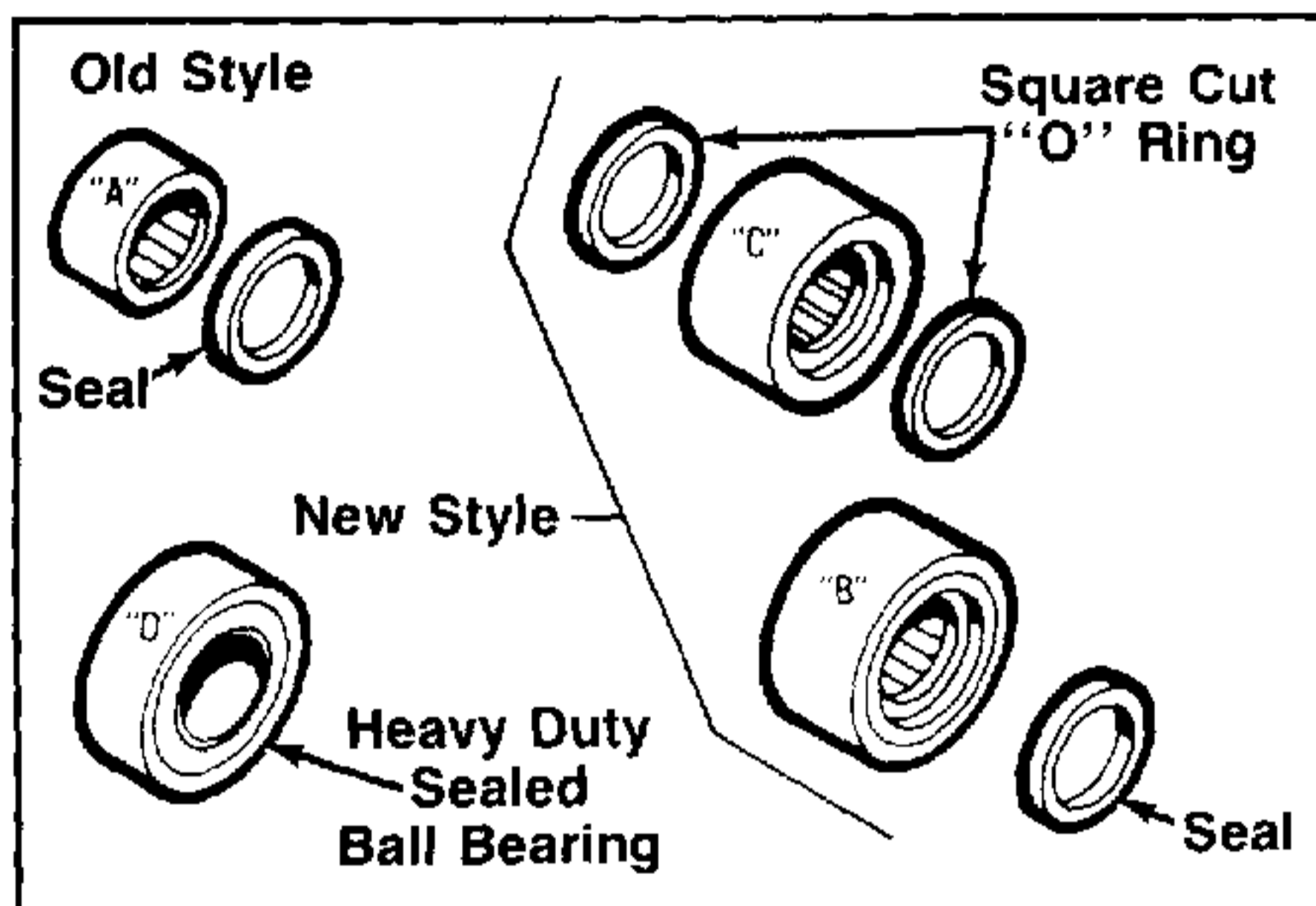

FIGURE 20.

9. Remove differential from case. Remove seals (2), needle bearings or ball bearings (2), flanged bushings (2) and thrust washer. See figures 20 and 21.

Teardown and reassembly procedures for this unit may be found on pages 2-21 through 2-24.

The 800 Series has used 4 styles of bearings on the axles. The earliest style "A" was a smaller loose cage needle bearing and must have the seal to the outside of that bearing. Style "B" must have the seal to the outside of the bearing. When bearing style "C" is used, a square cut "O" ring must be used on each side of the bearing. Bearing style "D" is a sealed ball bearing used in H.D. application. Styles "B," "C" and "D" are interchangeable. All needle bearings must be repacked with grease. See figure 20.

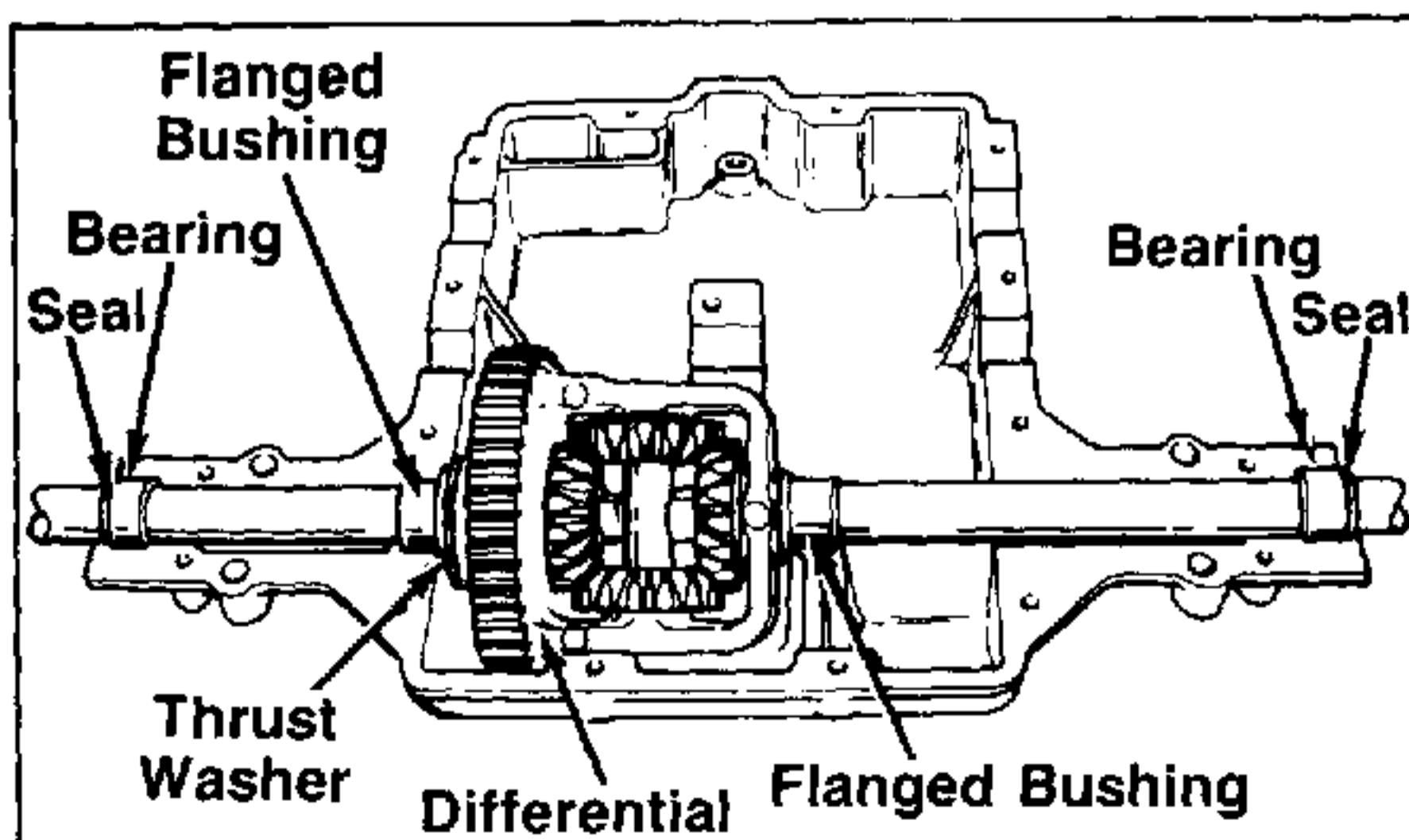

FIGURE 21.

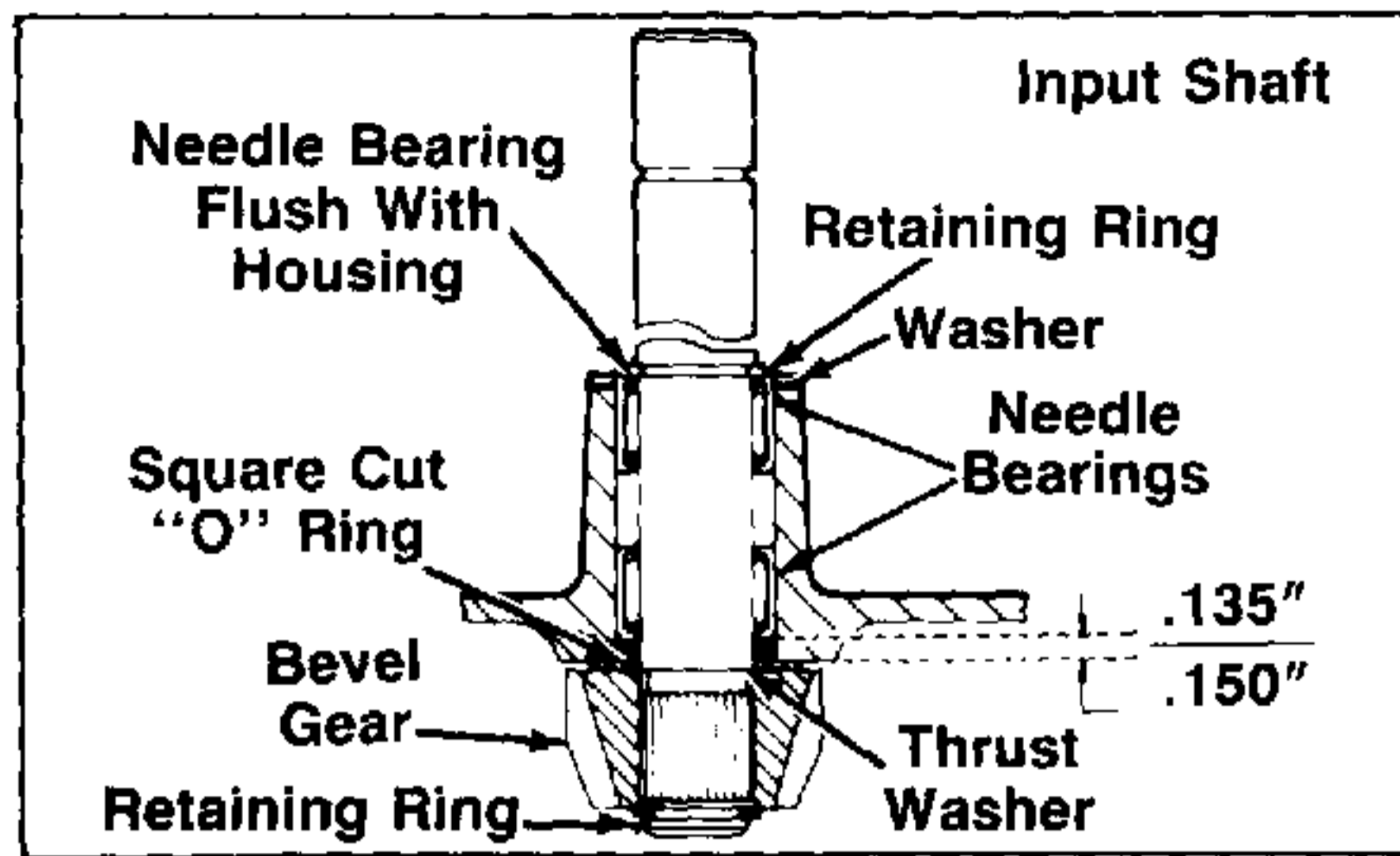

FIGURE 22.

- Remove retaining ring on bevel gear end from input shaft, remove bevel gear and pull shaft through case. The square cut "O" ring must be replaced, if removed. See figure 22.

Tool Part No. TC-670251 is used for removal and installation of needle bearings for the input shaft. The needle bearing on inboard side is installed .135/.150" below flush. See figure 22.

INSPECTION AND REPAIR

- Clean all parts in clean solvent and dry thoroughly.
- Examine the teeth and splines of gears, sprockets and shafts. The gears should slide freely on the shaft. Excessive wear of the splines will cause cocking of the gears.
- Examine all the gears and sprockets for broken teeth, wear or burrs.
- Inspect the chain and slide keys for wear.
- Discard all gaskets and seals. Replace with new gaskets and seals.
- Bearings, bushings and bearing surfaces should be thoroughly cleaned prior to inspection. Examine closely for scuffing, wear, pitting and abnormal conditions. Never clean the lubricant from new bearings. This lubricant prevents damage before the transaxle lubricant enters the bearing.
- Inspect the transaxle case and cover for cracks or damage.

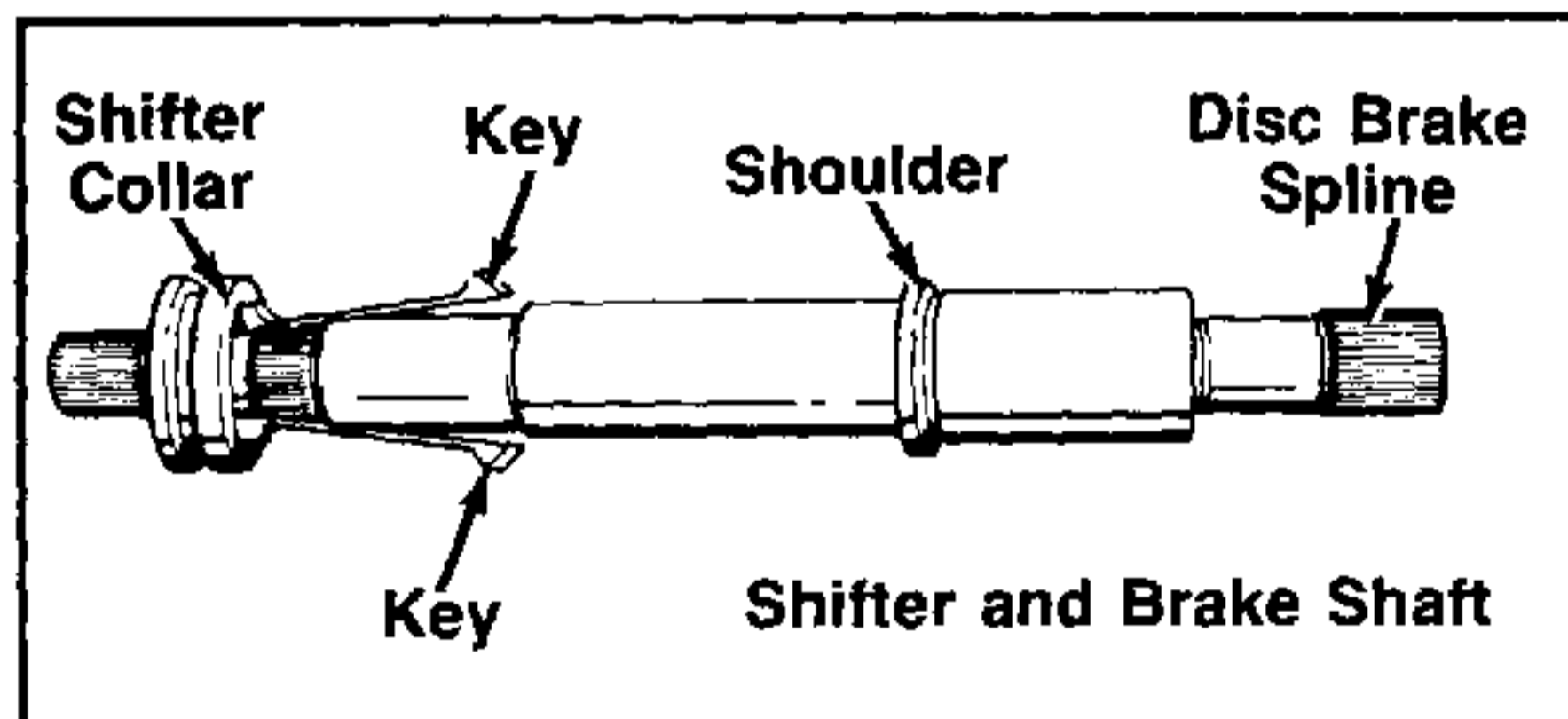

FIGURE 23.

REASSEMBLY

- Apply grease between bearings and install and secure the input shaft and bevel gear in the cover. See paragraph 10 under "DISASSEMBLY INSTRUCTIONS" and reverse the order. See figure 22.
- Grease both keyways and slide keys and collar on output and brakeshaft. Thick side of collar **MUST** face shoulder on shaft. See figure 23.
- When ready to install thrust washers and shifting gears on shifter and brake shaft, the 45° chamfer in the inside diameter of the thrust washers **MUST** face the shoulder on the output shaft. The flat side of the shifting gears **ALWAYS** face the shoulder on the shifter and brake shaft. See figure 24.

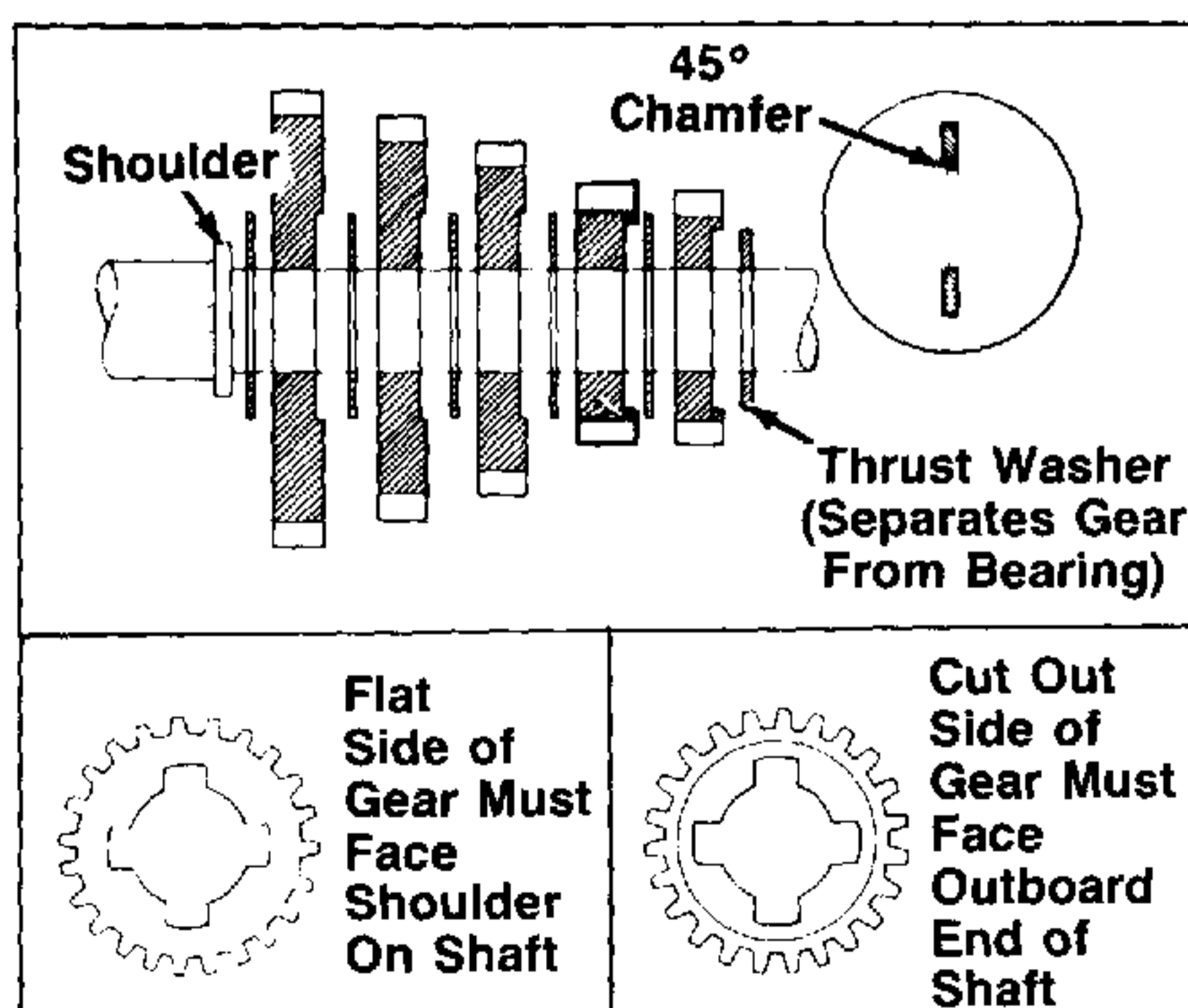

FIGURE 24.

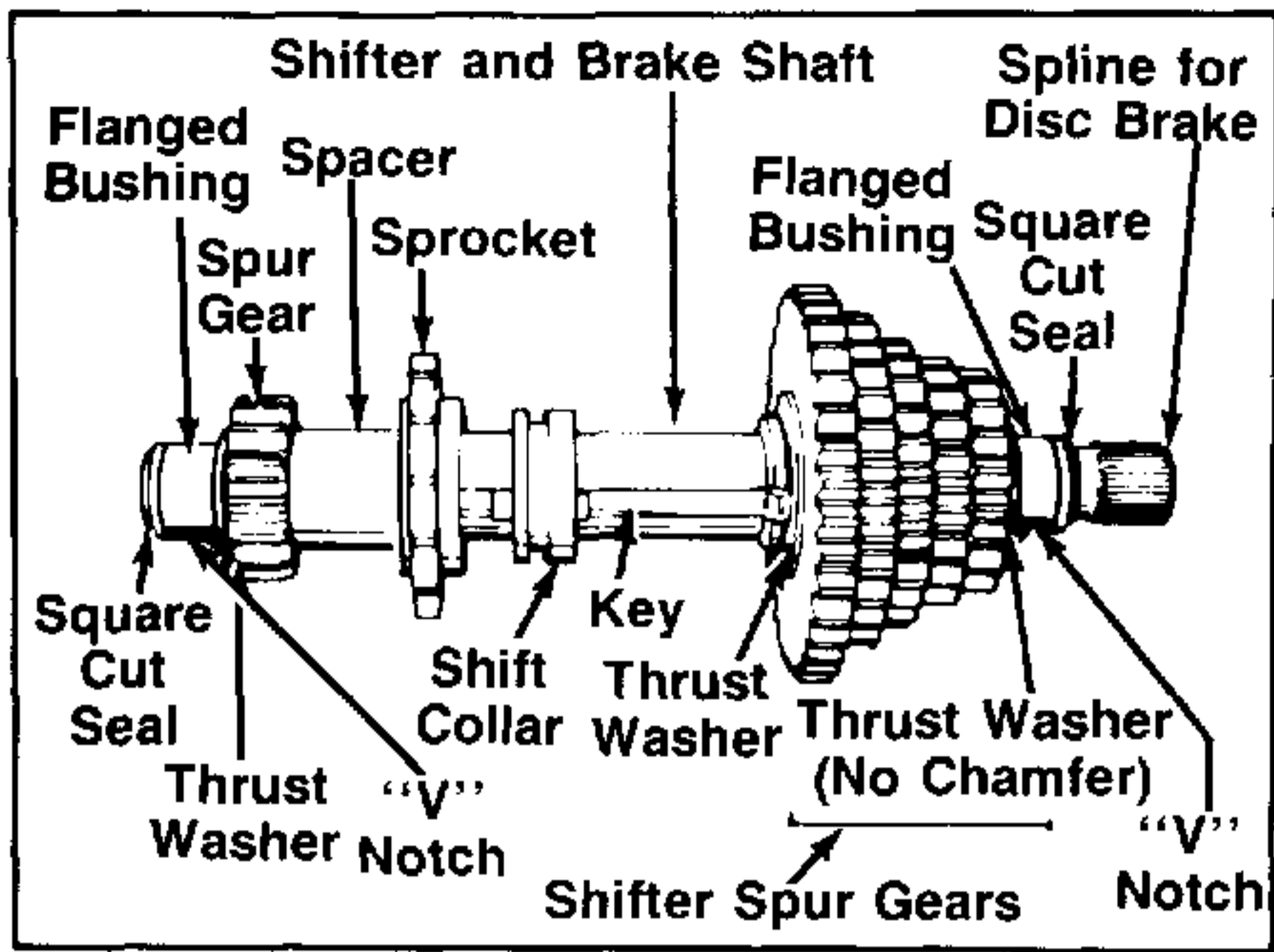

FIGURE 25.

- NOTE: The thrust washer on the shift gear end, of the shifter and brake shaft, does not have a chamfer on the inside diameter. Install sprocket, spacer, spur gear, and thrust washer on output shaft. Be sure collar on sprocket faces the shift collar. Install bushings on both ends of shifter and brake shaft, install square cut "O" rings on end of flanged bushings. See figure 25.

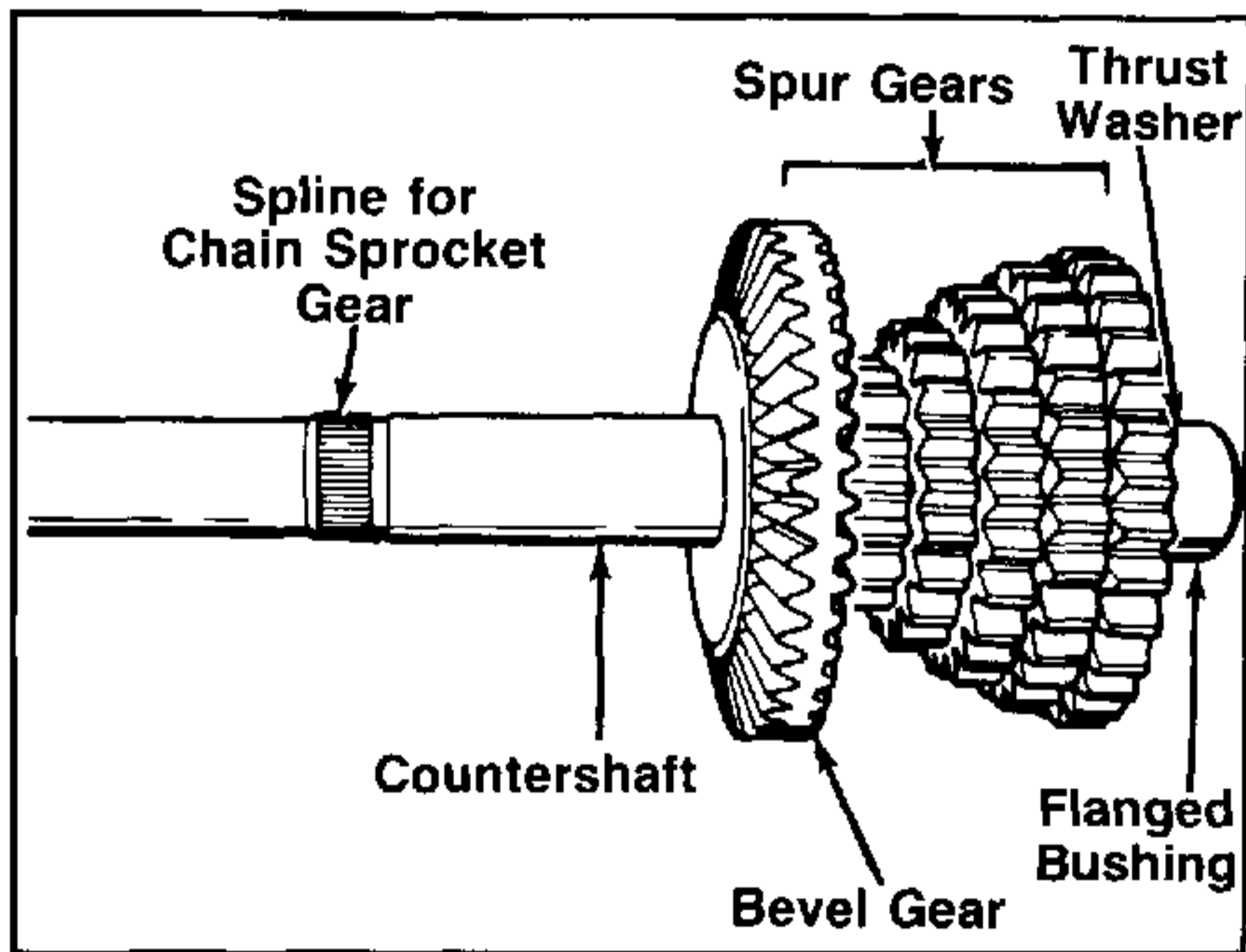

FIGURE 26.

- NOTE: The bevel gear may be installed one of two ways. The models used in Cub Cadet Lawn Tractors have the wide angle of the bevel gear facing the left as shown in figure 26.
- Install bevel gear and smallest to largest spur gears, thrust washer and bushing to the countershaft. Install the sprocket. See figure 26.

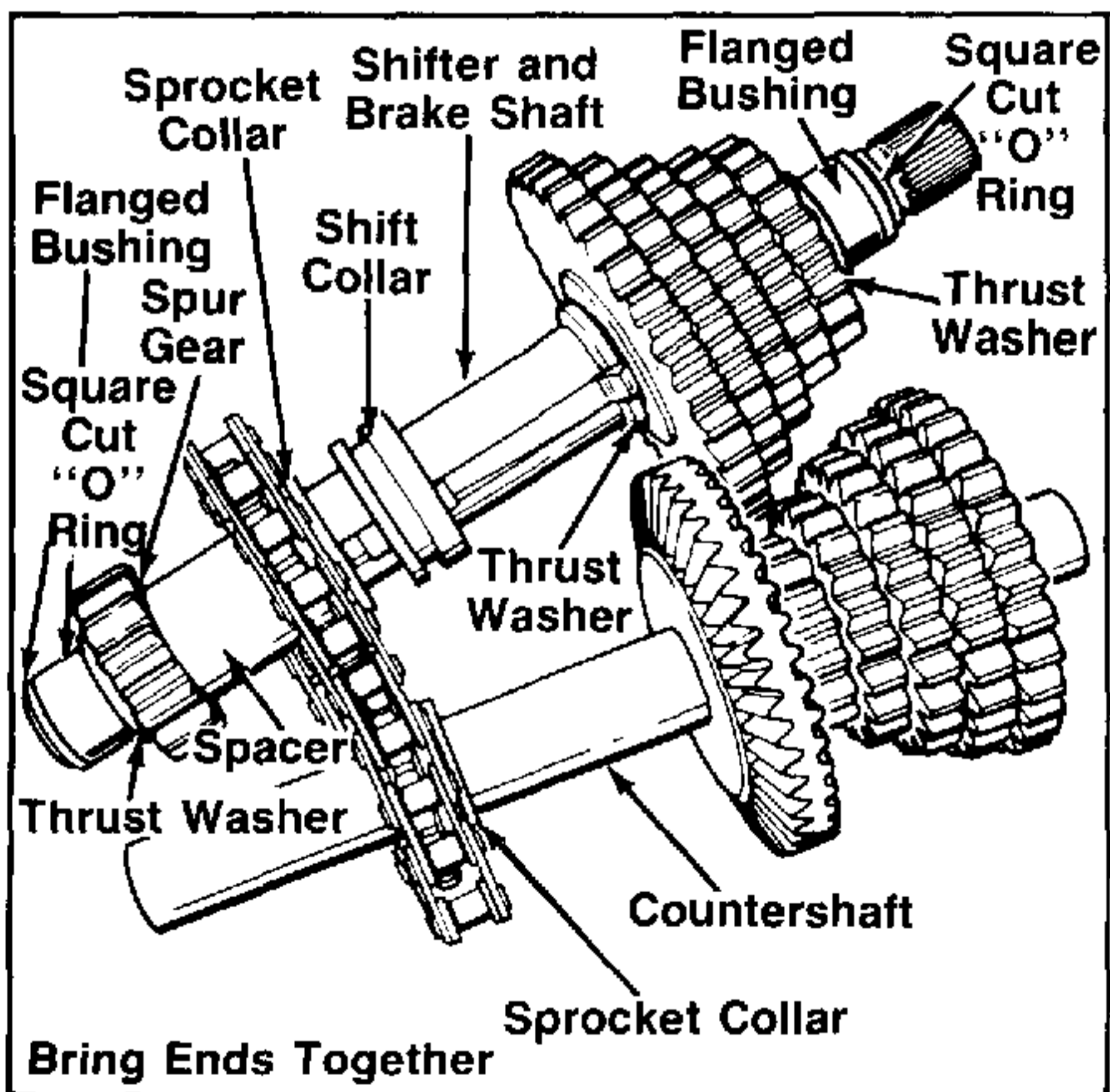

FIGURE 27.

- With the shifter and brakeshaft and countershaft ends angled together, install the chain on the sprockets. See figure 27.

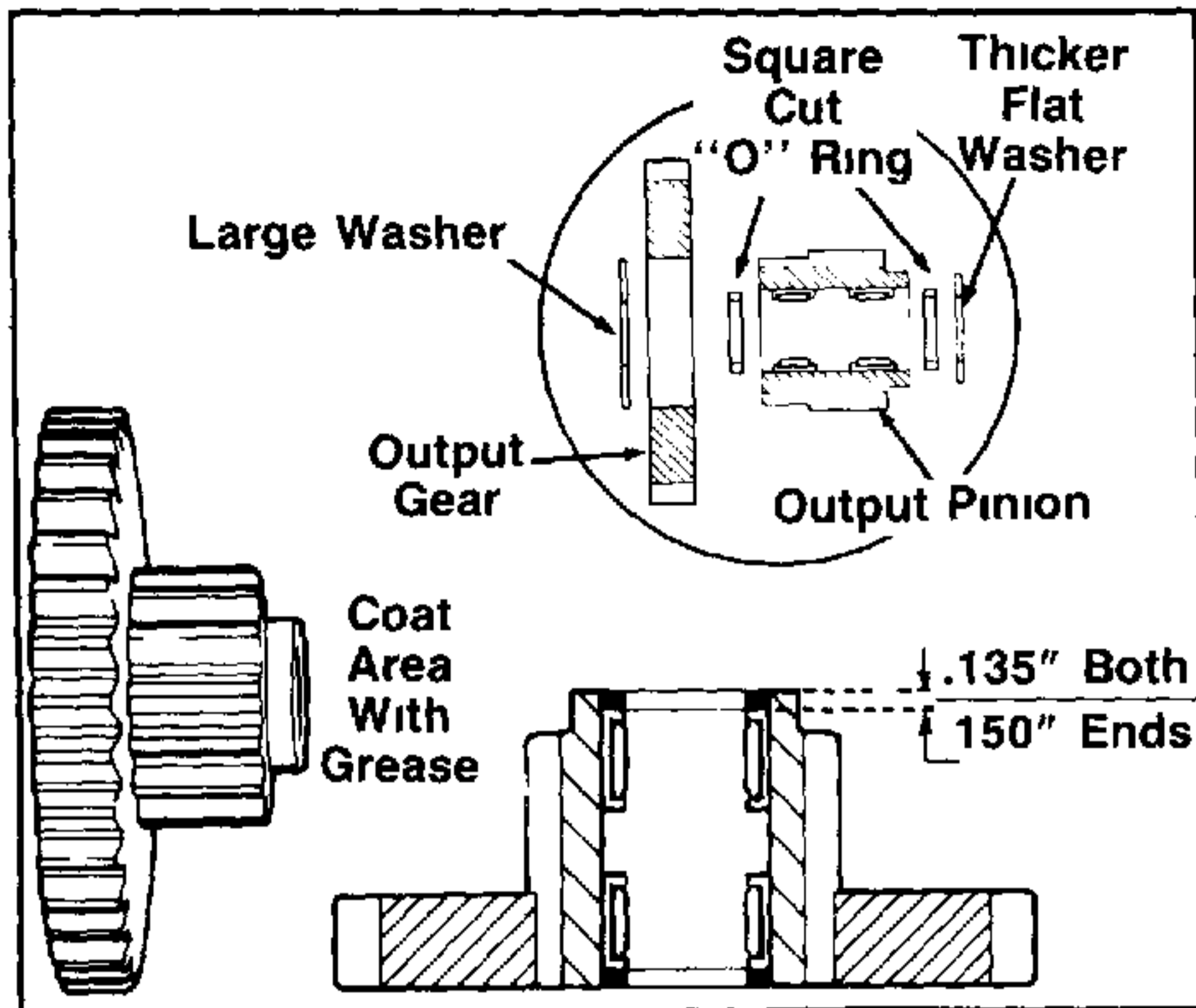

FIGURE 28

- 7 For correct positioning of the needle bearings use removal and installation Tool Part No TC 670252 Fill the area between the needle bearings with grease before installing on the countershaft See figure 28

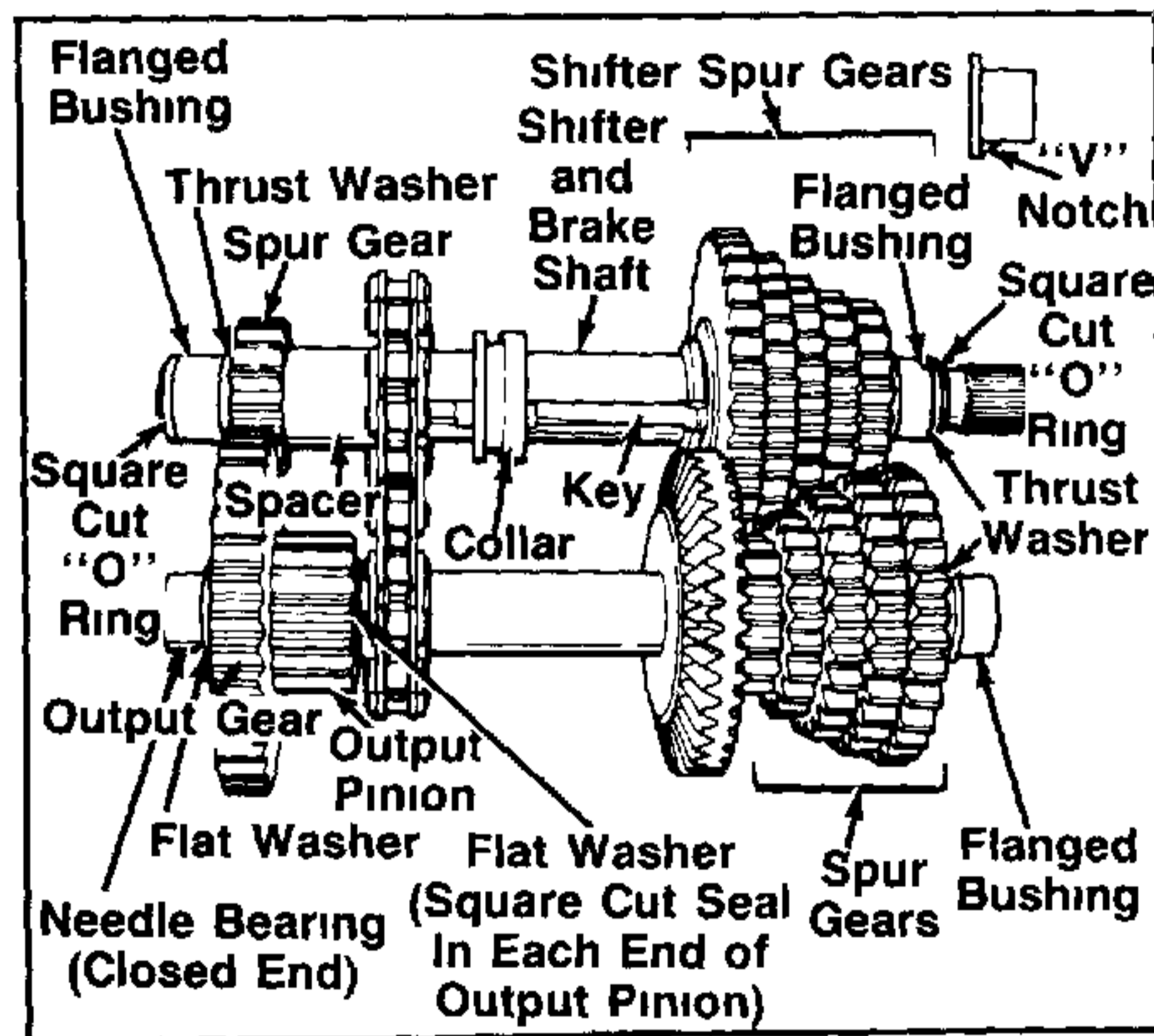

FIGURE 29

- 8 Install the output and pinion gears the flat washer, square cut rings, needle bearing (closed end) and spacer on one end and thrust washer and flanged bushing on the other end Note that the 'V' notch on the bushing fits into recess 'V' in case See figure 29

A square cut seal fits in each recessed end of output pinion Also one square cut ring fits into recessed end of needle bearings (closed end)

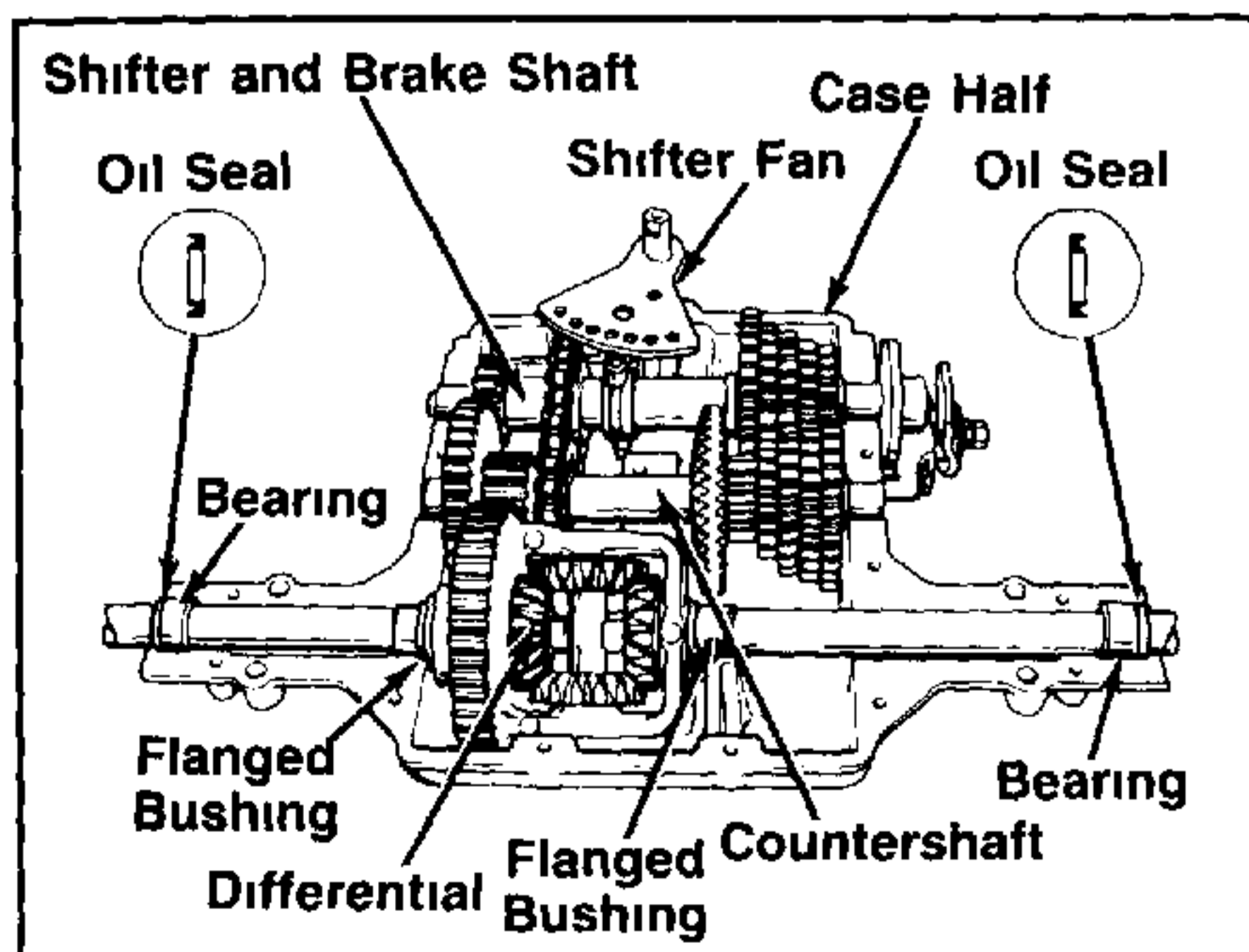

FIGURE 30.

9 DIFFERENTIAL ASSEMBLY

Install the flanged bushings (2) flat washer needle bearings or ball bearings (2) and oil seals (2), with seal grooves facing out

For teardown and reassembly of the differential see pages 2-21 through 2 25

Install differential in case

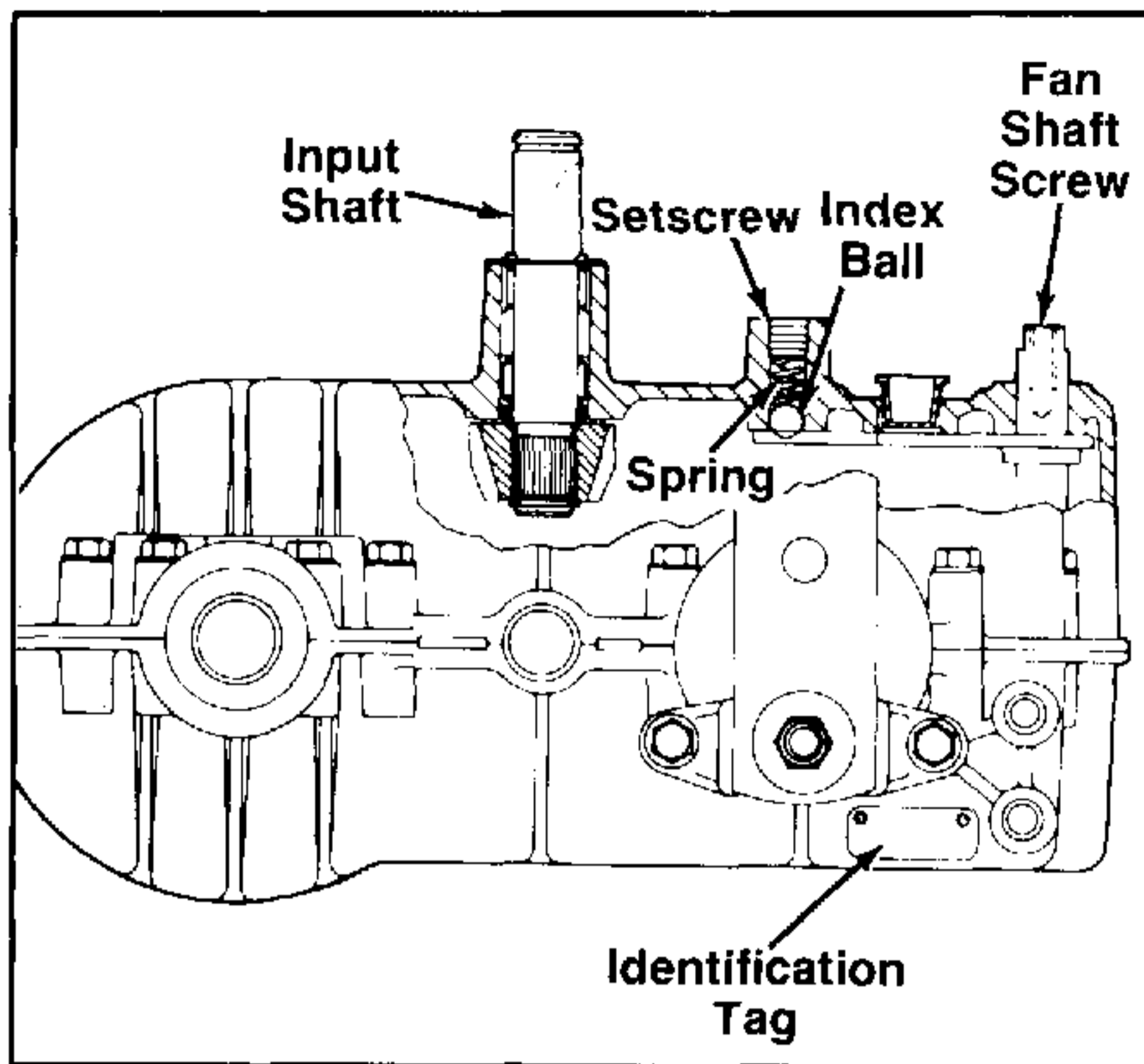

FIGURE 31.

10. Install shifter assembly, (shaft, pins and fans). Pack 36 oz. Cub Cadet multi-purpose grease (E.P. Lithium Base) around bearings and gearing, and reinstall cover on case. Torque cap screws 90-100 inch pounds.

Install index ball, spring and setscrew in that order into cover, and slowly tighten the screw 1 turn below flush.

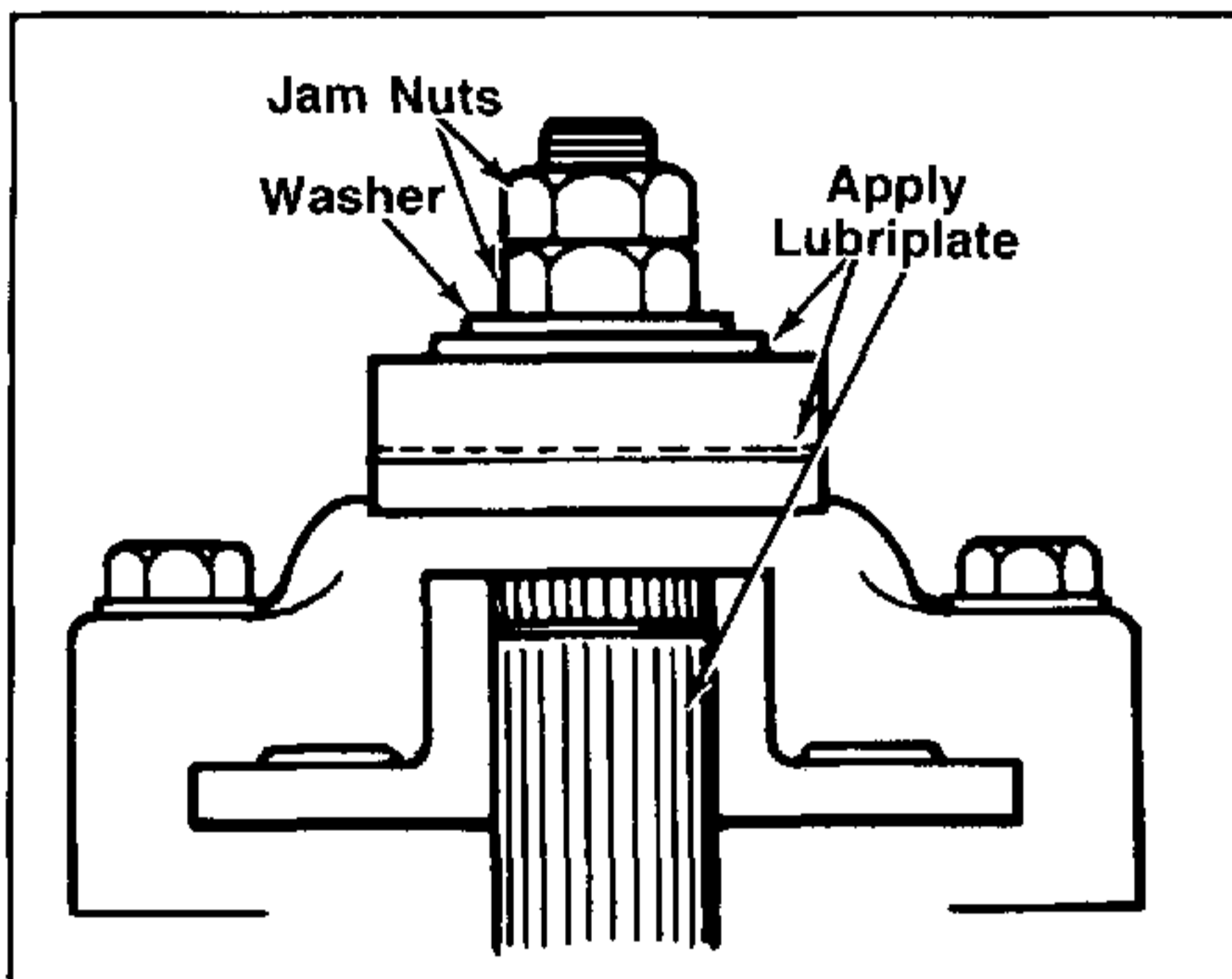

FIGURE 32.

11. Prior to installing the brake assembly, apply a light film of lubriplate to the inside of lever portion which contacts pins also to outside of lever which contacts flat washer and between shaft O.D. and bore of brake disc. Brake pads and brake disc must be free of grease and oil. Install brake and linkage and adjust to disengage when clutch is engaged. Consult equipment Owner's Manual.

Check for binding by turning input shaft. Install transaxle on equipment.

NOTE: To secure brake lever, hold bottom nut and torque top nut to 100 in. lbs.

Brake and linkages may vary.

NOTE: If adjusted incorrectly, the brake will do one of two things:

- a. It will not brake (stop) the vehicle when the brake is applied or,
- b. If adjusted too tightly, a drag or continued braking effect will be evident until the brake wears out.

5-SPEED DIFFERENTIAL

DISASSEMBLY

1. Same as disassembly for model 600, except for additional parts on the axle.
2. Remove and inspect seals, bearings and washers for wear—replace if required.
3. If differential was disassembled note positioning of differing length axles so correct reassembly may be performed.

REASSEMBLY

1. Reassemble in reverse order of disassembly.
2. Install seal cup end out from the center of differential to prevent dirt entry.

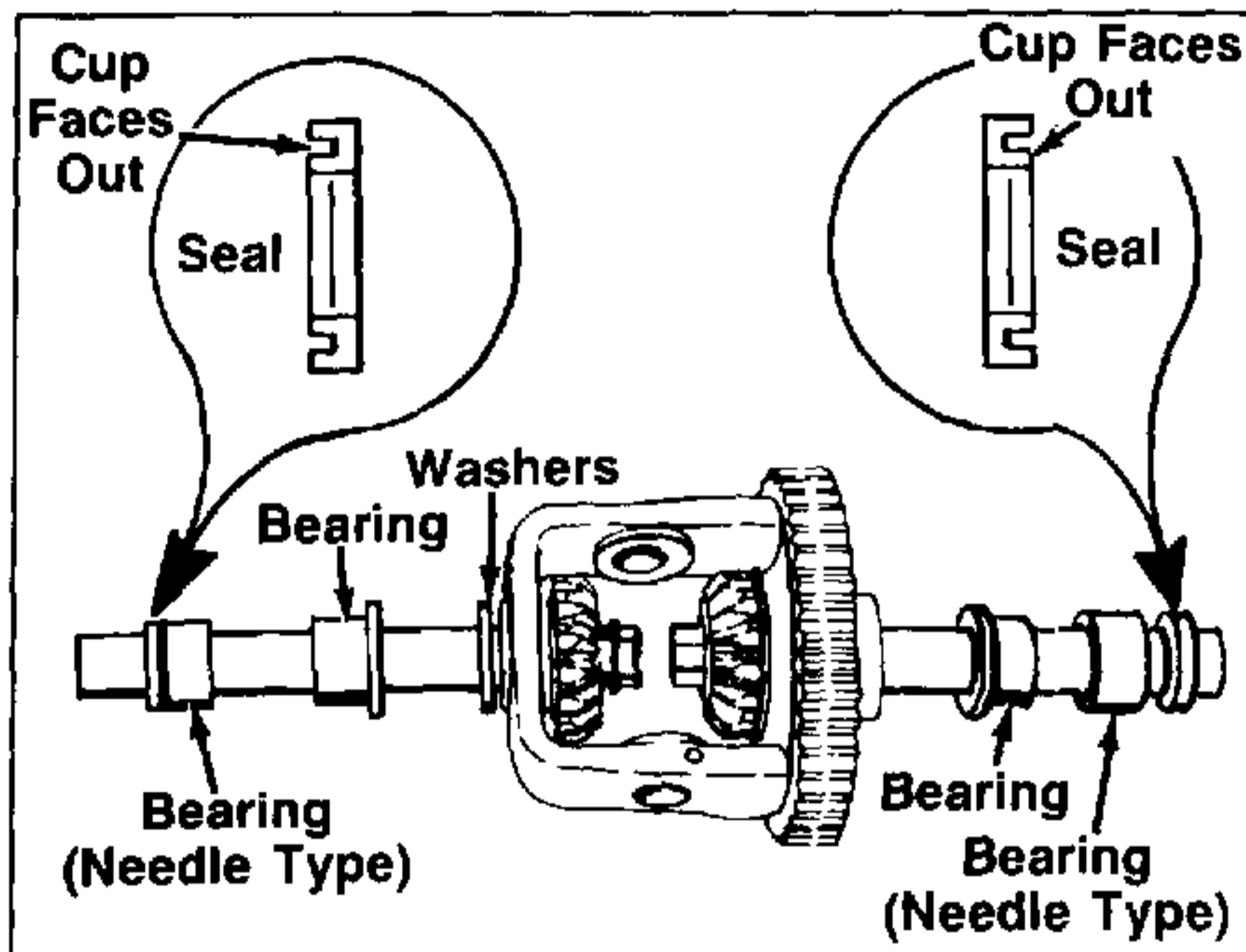

FIGURE 33.

The 800 Series has used 4 styles of bearings on the axles. The earliest style "A" was a smaller loose cage needle bearing and must have the seal to the outside of that bearing. Style "B" must have the seal to the outside of the bearing. When bearing style "C" is used, a square cut "O" ring must be used on each side of the bearing. Bearing style "D" is a sealed ball bearing used in H.D. application. Styles "B," "C" and "D" are interchangeable. All needle bearings must be repacked with grease.

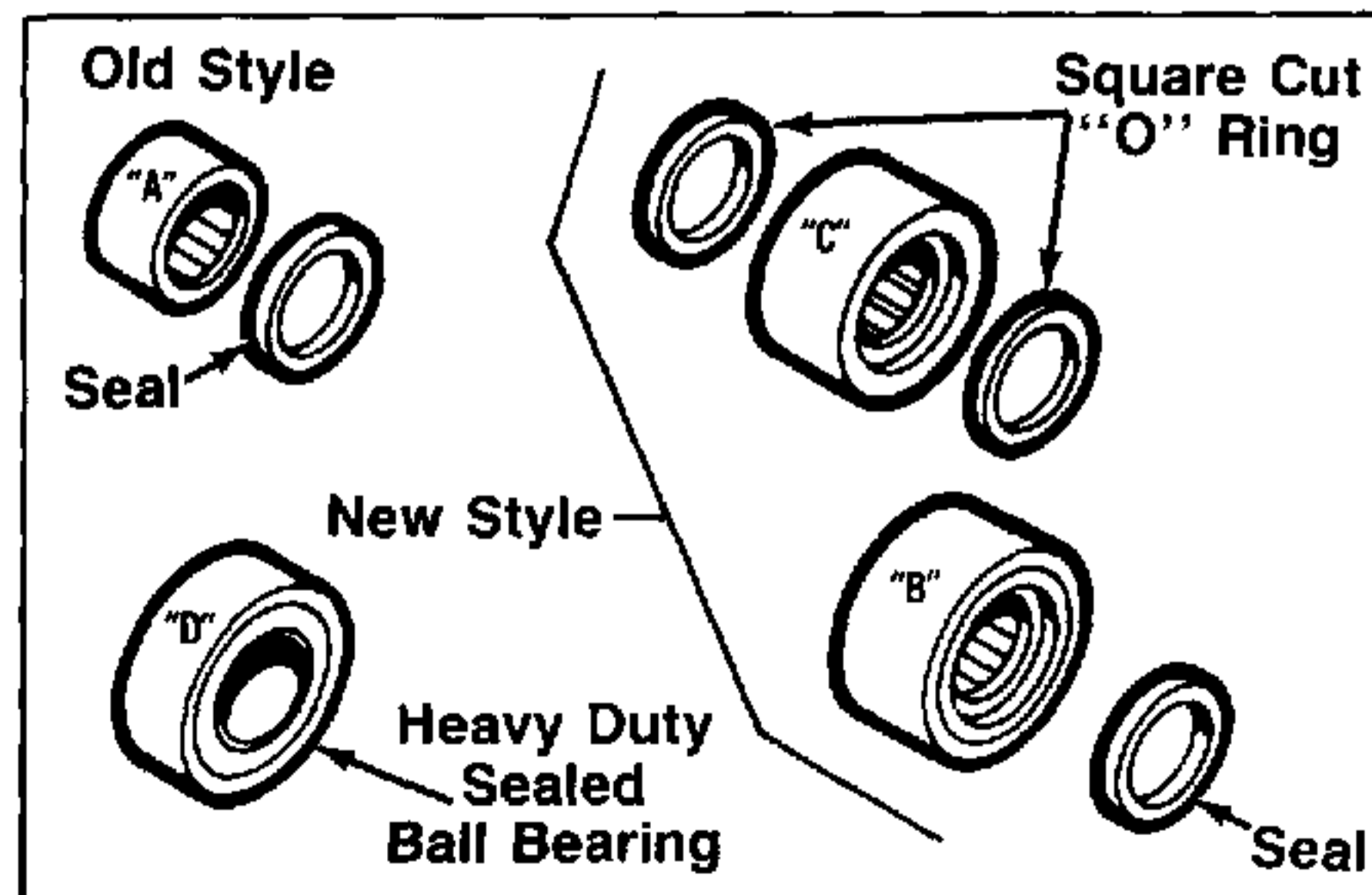

FIGURE 34.

DIFFERENTIAL

Remove differential from case. The differential is one of the first of its kind in that the unit rides and is held together in the case and cover. Also remove the flat washers off the axle ends.

DIFFERENTIAL ASSEMBLY

When assembling this unit, make sure all parts are there first, because the unit is put together in your hands and placed in the case at the same time.

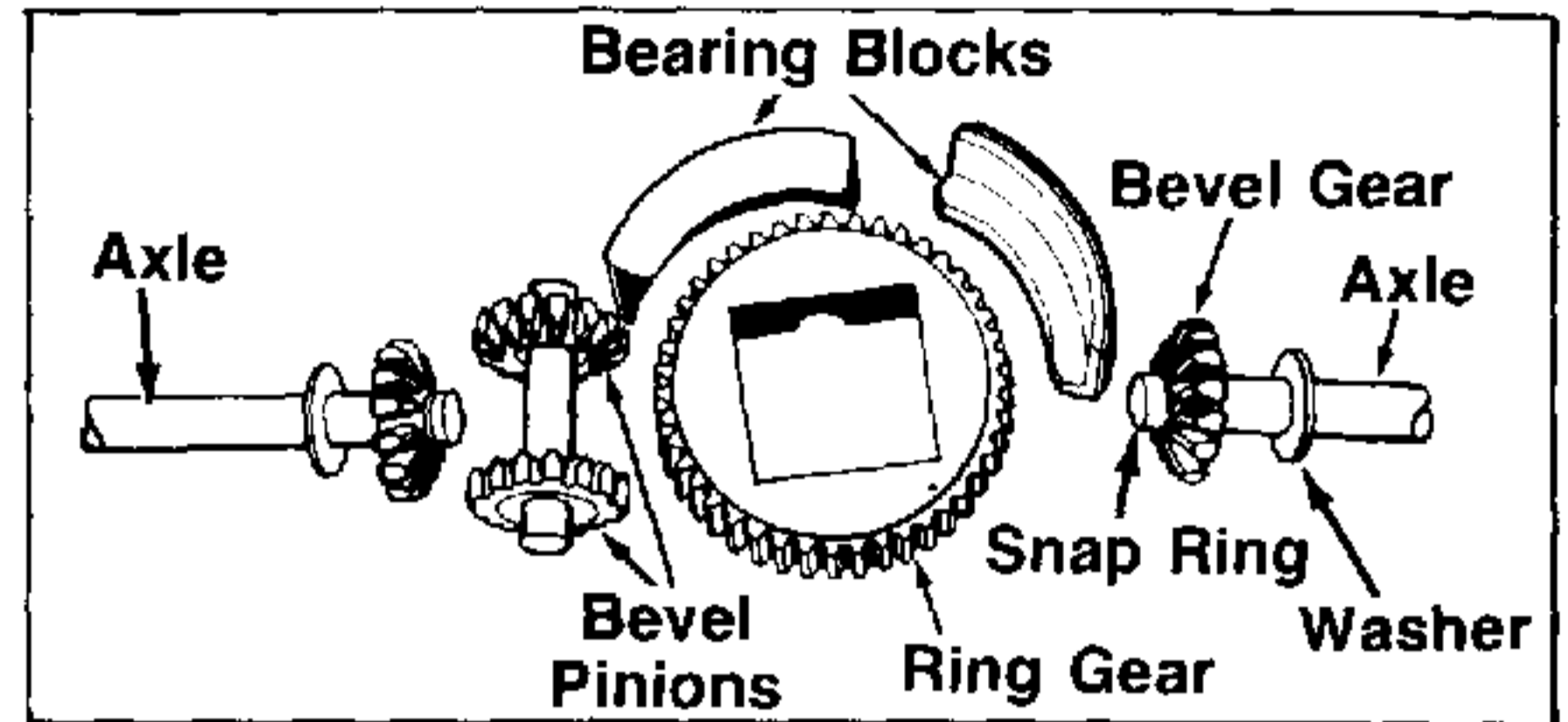

FIGURE 35.

DIFFERENTIAL USED IN PEERLESS CAST IRON CASING UNITS

NOTE: The models covered are the 1200, 1300, 1700, 2000, 2300 and 2400 series.

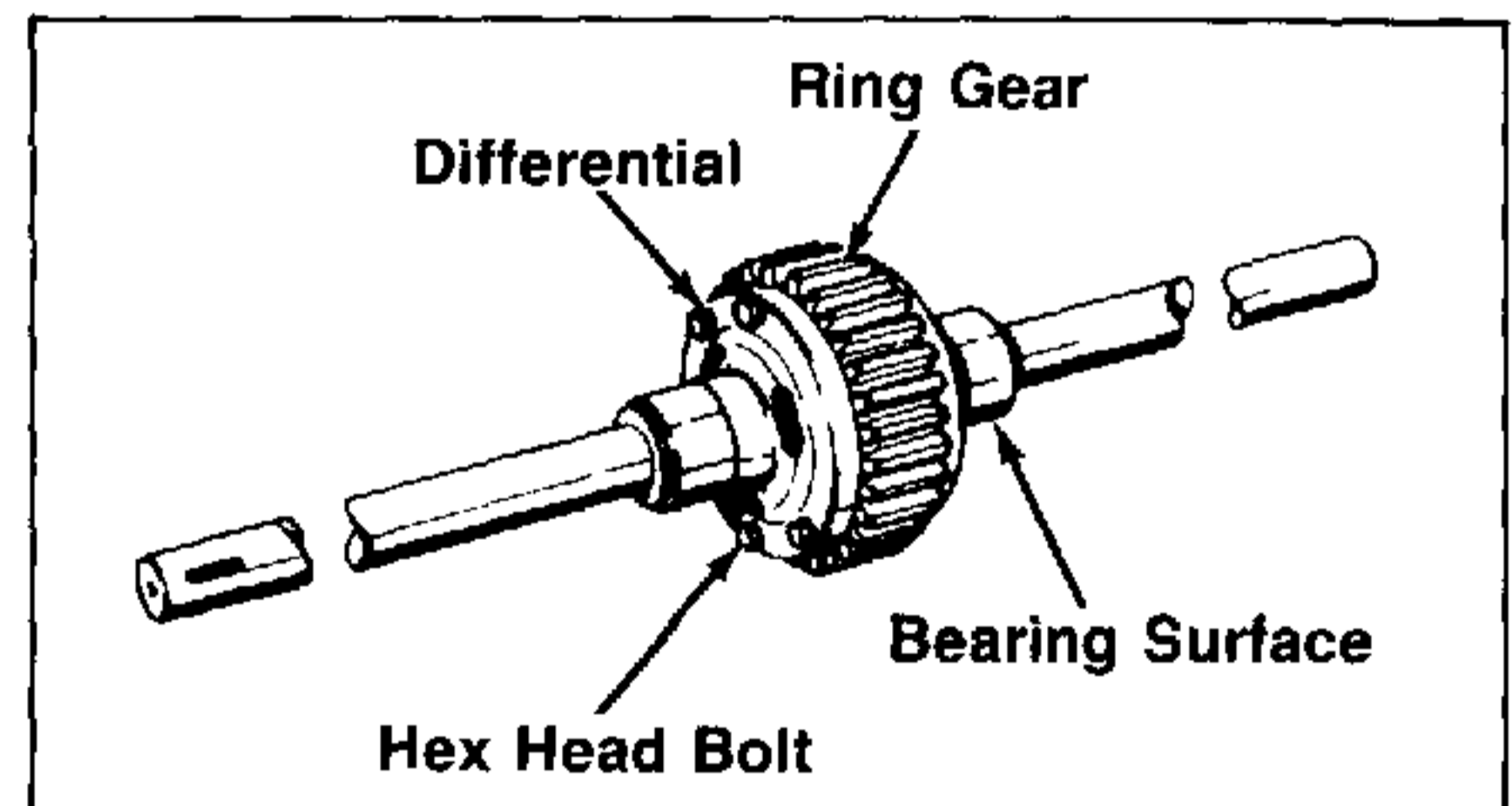

FIGURE 36.

1. The differential construction may vary from the illustrations but is basically similar.
2. The 1200 series differential carrier is supported directly on the axle (1). Roller thrust bearings (2) are used between the bevel gear (3) and the differential carrier (4). This illustration shows axles with snap ring (5) retainers, some earlier production had rolled over axle ends to secure the assembly. Thrust washers (6) are used at the ends of the differential carriers and case/cover thrust face. The drive pin (7) and drive blocks (8) are similar to those used on the 1700 series. Replace the differential carrier if worn in excess of .878 at point A.

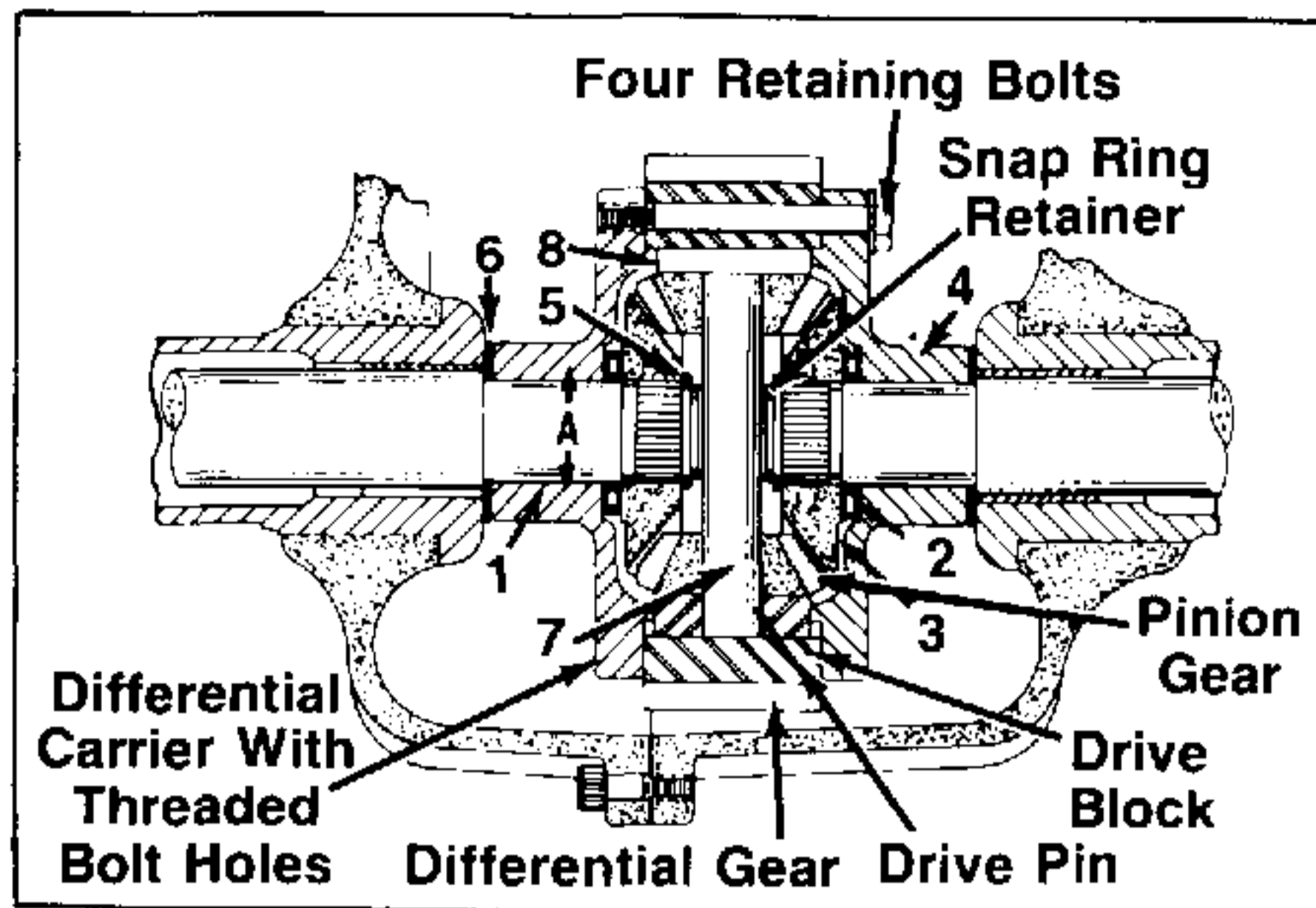

FIGURE 37.

3. The 1700 series differential has a rolled end (1) to retain the bevel gear to the axle. The 1700 differential is also made with snap ring retainer on the axle. In event it is necessary to replace parts, the new axles will be snap ring type and the spacer (2) will be eliminated.

Replace differential carriers worn in excess of 1.004 at point A.

4. Roller thrust bearings (3) and (4) are used between the carrier and case/cover and between the bevel gear and carrier.

The bushings (5) support the axles.

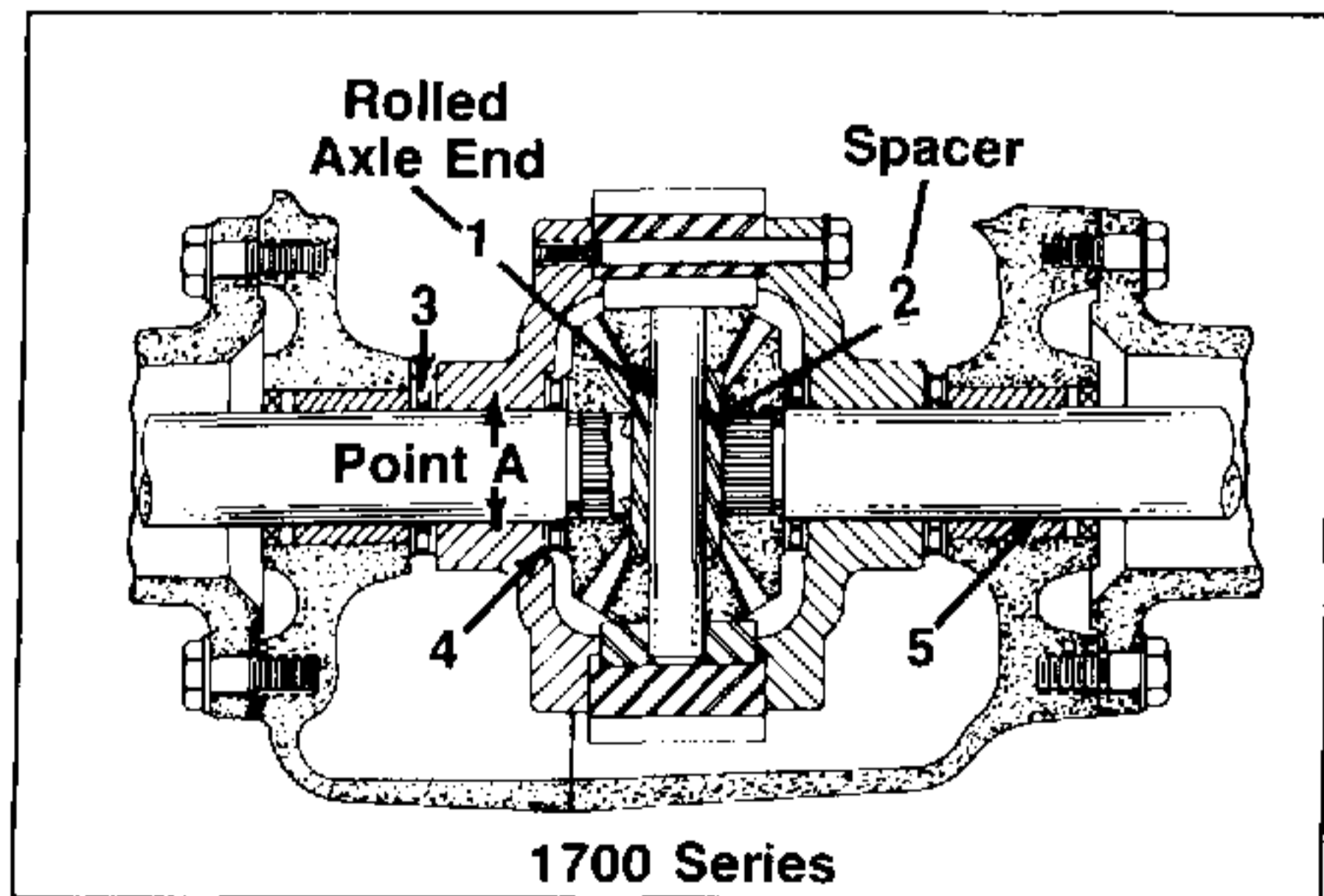

FIGURE 38.

5. The 2000 series, three speed and the 2300 series, four speed differential. Examine the external bearing race on the differential carriers (1) for wear or pitting. Replace if evident. The differential carriers in this assembly have replaceable bushings (2). Replace if worn in excess of .878 at point A. See Chapter 11, Bushing and Bearing Service. These differentials have been built with rolled axle ends and also snap rings (3), as illustrated.

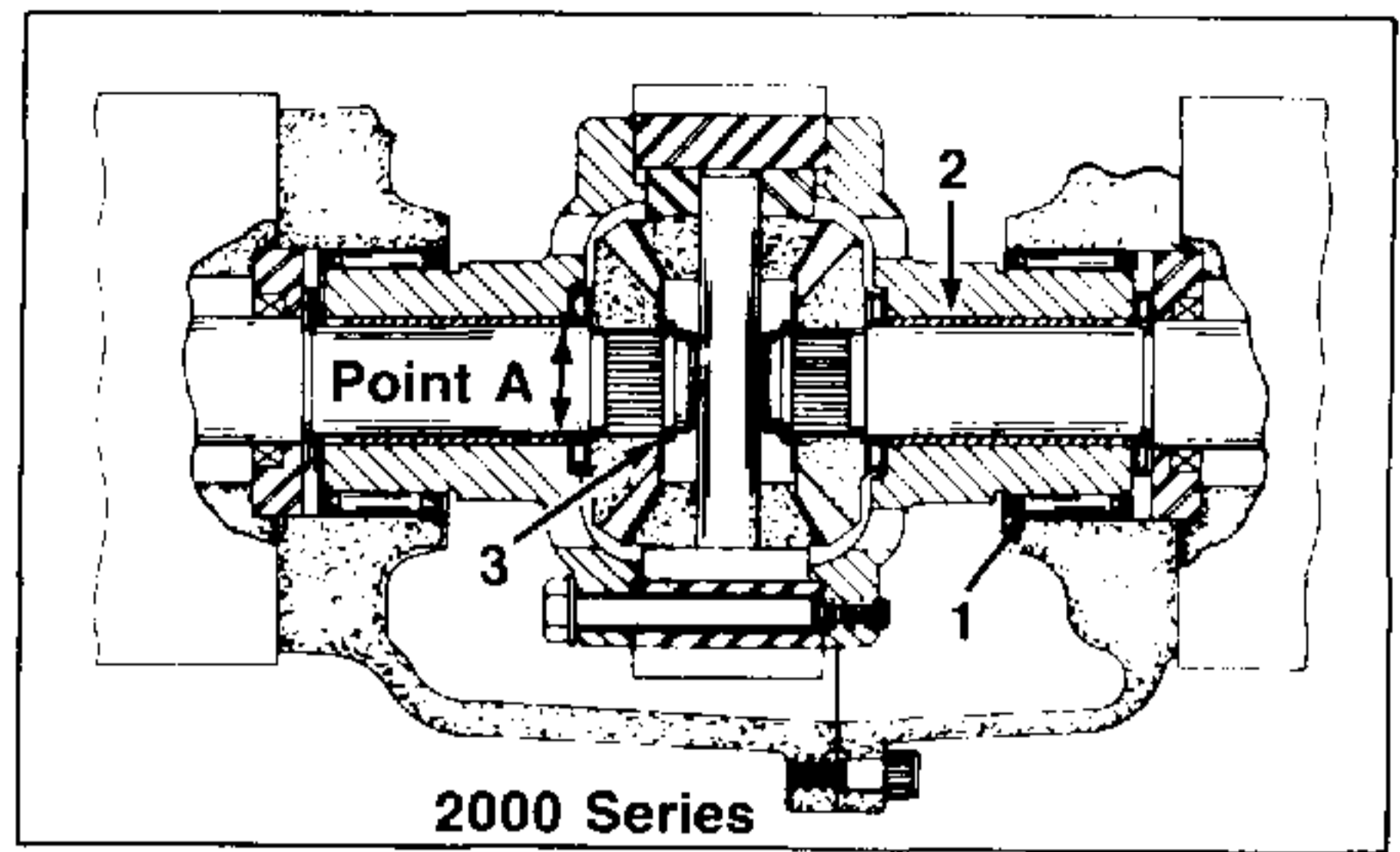

FIGURE 39.

DISASSEMBLY

- a. Clean the differential assembly, then check and note the axle lengths and their relation to the heads of the four hex screw bolts.
- b. If the unit will not turn freely, note where the unit binds. Check and replace those parts.
- c. Place the differential in a large vice with soft jaws (hex head bolts up). Do not clamp the vise on the bearing race of a differential carrier.

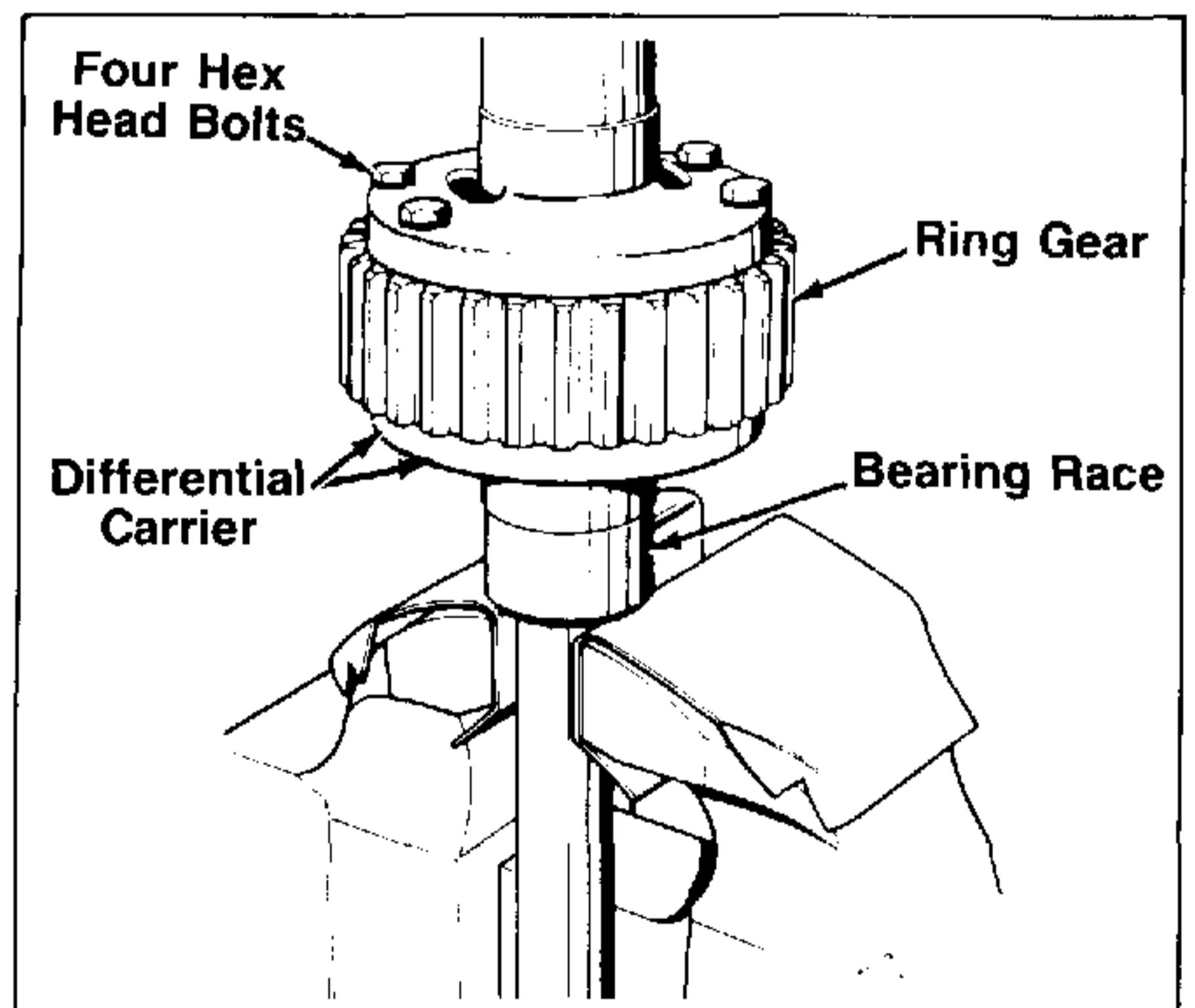

FIGURE 40.

1. Remove the four hex head bolts and the upper axle and differential carrier. Remove the drive blocks, pinions, drive pin and thrust spacer if used, by lifting out of the ring gear. Tap the ring gear lightly with a mallet to loosen from the differential carrier.

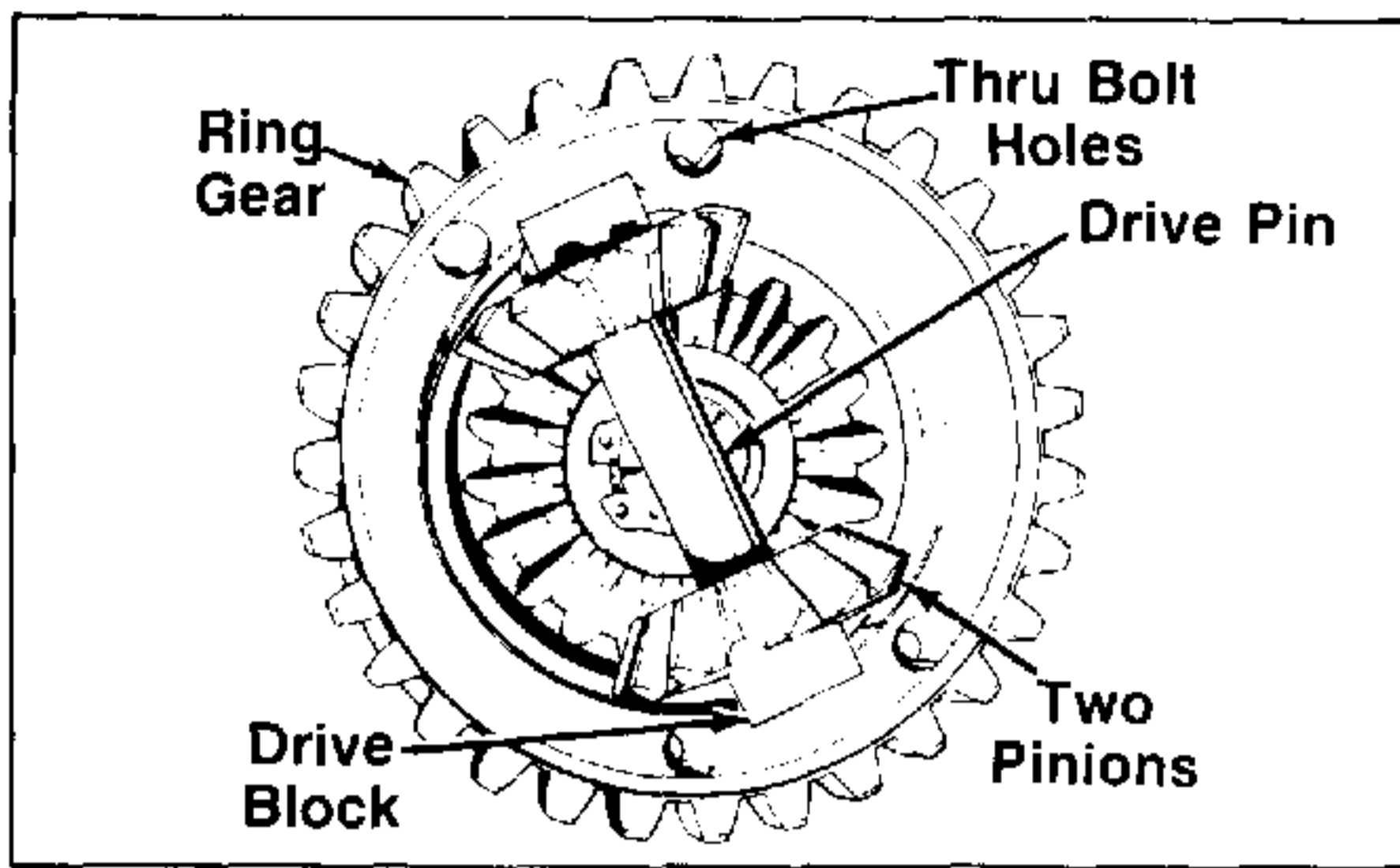

FIGURE 41.

2. If a snap ring is used, the axle assembly may be disassembled. If the axle end has been rolled, do not attempt to break the rolled retaining edge. The parts are to be replaced as an assembly.
3. Remove the snap ring and the thrust washer, if used. Separate the bevel gear and the differential carrier from the axle.

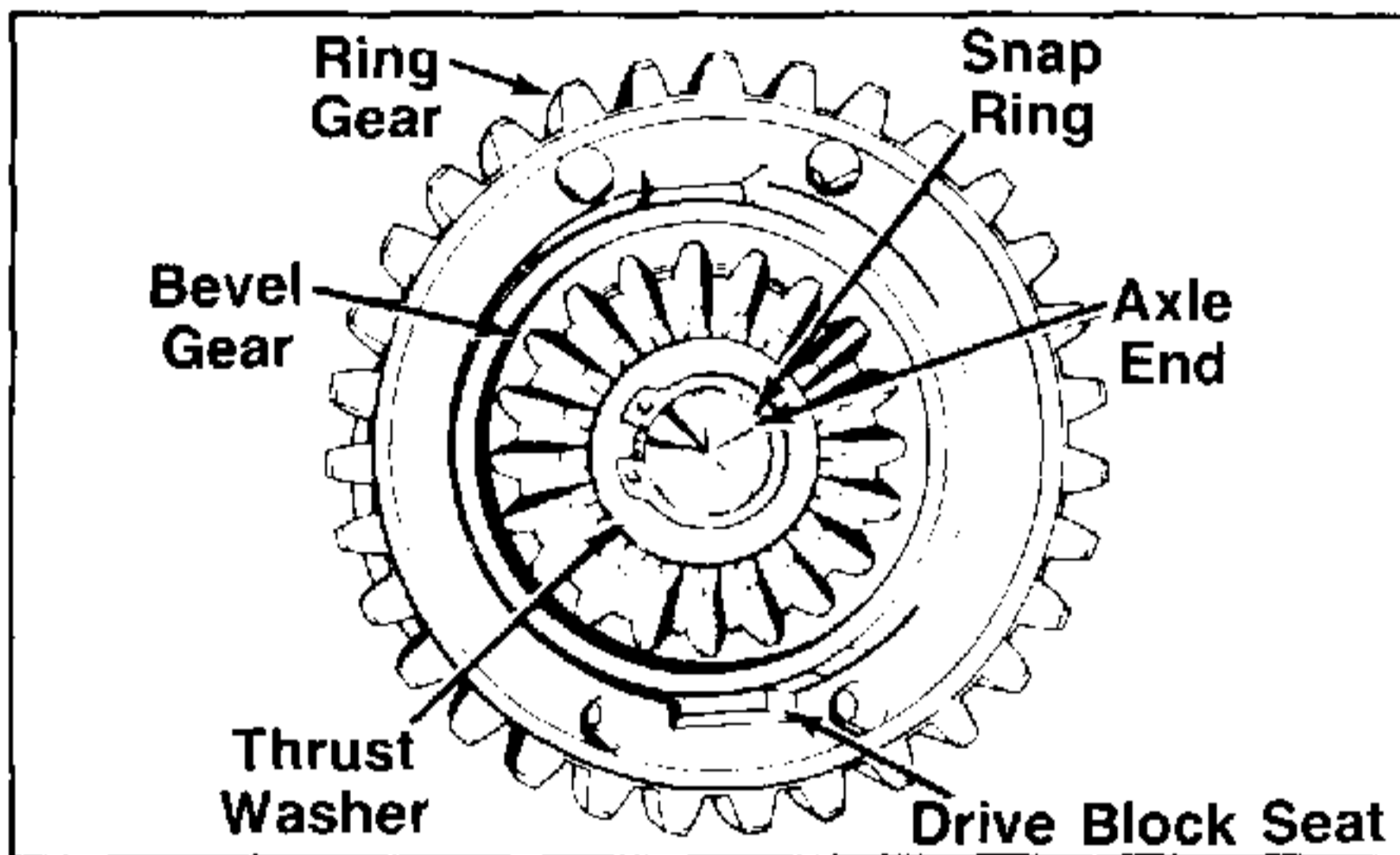

FIGURE 42.

INSPECTION

- a. See Chapter 8, for Bushing and Bearing Service.
- b. Examine gears for wear, cracked or chipped teeth. Check the internal splines of the gears and axle if the gear is removable. If excess play is noted, it may be necessary to replace the individual parts or both the gear and axle.
- c. Examine drive pinions, drive pins and drive blocks for wear and damage. Replace excessively worn pinion or the drive pin.
- d. Examine the differential carriers. One has threaded holes and the other has larger holes so that the bolts will pass through. Be sure to order the correct replacement parts.

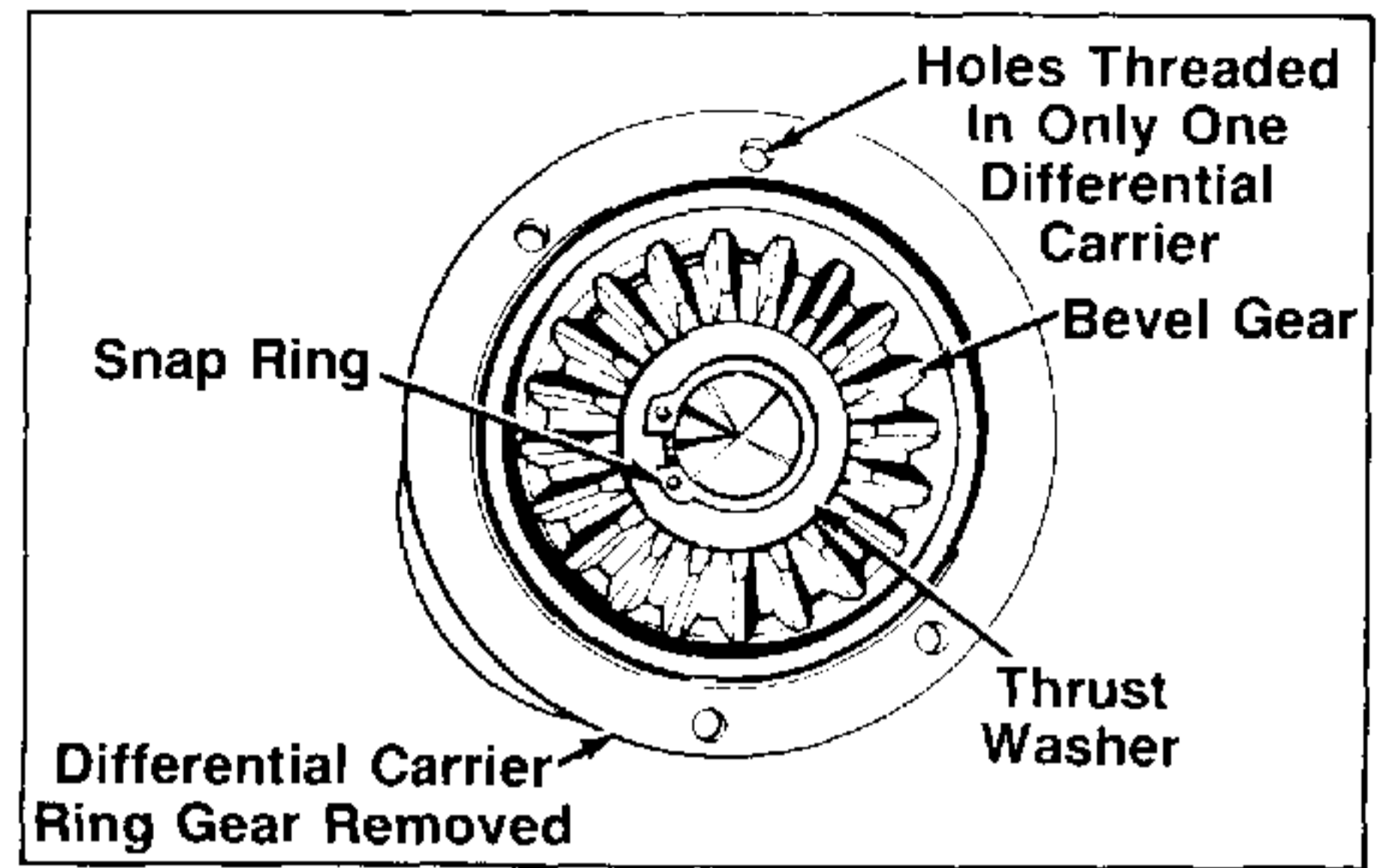

FIGURE 43.

- e. Examine the internal bearing diameter of the differential carriers.
- f. When assembling thrust bearings, always place a hardened thrust washer on each side of the caged thrust rollers. Never use the caged thrust rollers without the thrust washers.

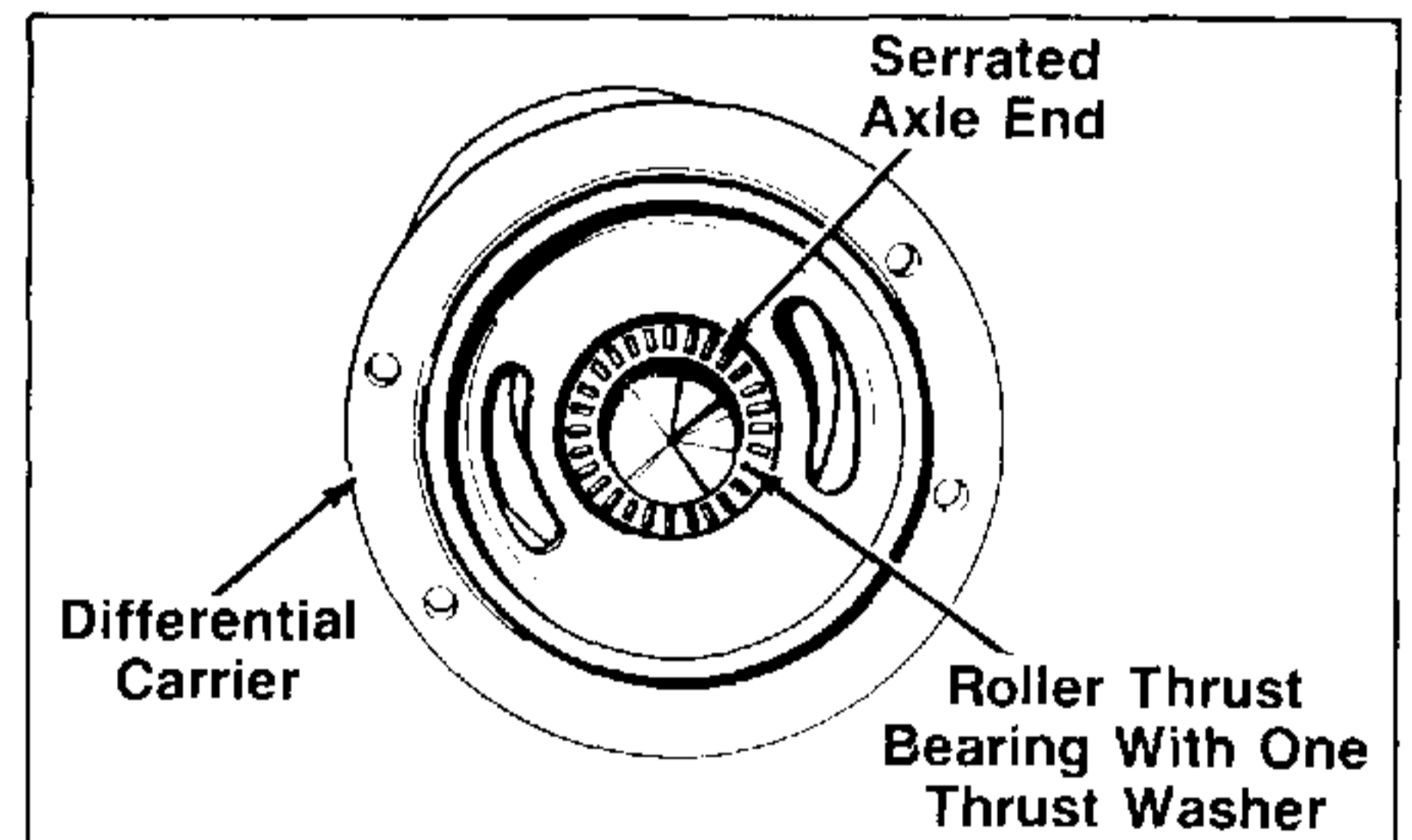

FIGURE 44.

REASSEMBLY

- a. Oil all parts during reassembly.
1. Select the correct axle for the side of the differential opposite the hex head bolts. If the wrong axle is used it will require complete teardown of the differential, or possibly the entire transaxle, if the error is not detected until later.
2. Clamp the axle, in a soft jaw vise (not bearing or oil seal surfaces). The differential carrier with threaded holes is assembled to this axle.
3. Torque the four hex head bolts to 7 ft. lbs.

TESTING

- a. Test differential action by holding the upper axle vertically, and spinning the differential. The unit should spin and rotate freely. Place the assembly on the bench and rotate both axles in different directions. If any binding is noted in either test, check retaining bolt torque, gear meshing, or bearing surfaces in the differential carriers. Little or no play should be apparent between the axles and carriers.

DUO-TRAK* DIFFERENTIAL OPERATION

A cylindrical spring in the center of the unit presses the ten pinion gears against their pockets setting up a resistance to rotation among them. This resistance serves to lock up the gears in the differential until a moderate tractive difference in the wheels causes the resistance to be overcome. At this time the unit will act similar to a regular differential. The break away occurs when the equipment is turning, but under different tractive effort situations, as operation on wet grass or snow. The spring acts to transmit torque to the nontractive wheel to move the equipment.

*DUO-TRAK is the trademark of a patented limited slip differential designed by Illinois Tool Works.

DISASSEMBLY, INSPECTION AND REPAIR

Parts breakdown will be found on next page.

Remove four through-bolts.

Separate axle assemblies from body cores.

To disassemble axles, remove snap ring and retained parts. Be sure that flanged thrust washer goes toward hub end of axle upon reassembly.

Use a pair of large 90° tip snap ring pliers and remove the cylindrical spring putting tension on the ten pinion gears. Once the spring is removed, the gears can be removed.

Separate the two body cores from the ring gear.

ASSEMBLY

Install body cores to ring gear so that pockets in one core are out of alignment with pockets in other core.

Reassemble thrust washers, bearing, carrier and side gear to axle and secure with the snap ring. Install pinion gears on one side, then use the differential carrier and axle to hold them from falling out when the unit is turned over. The side gear must mesh with the flat pinion.

Install pinions in other side to mesh with previously installed pinions.

Insert the cylindrical spring with a pair of large 90° tipped snap ring pliers so that it bottoms on the side gear. All ten pinions should be in contact with the spring.

Install other axle and secure assembly with four through bolts. Torque to 7-10 ft. lbs.

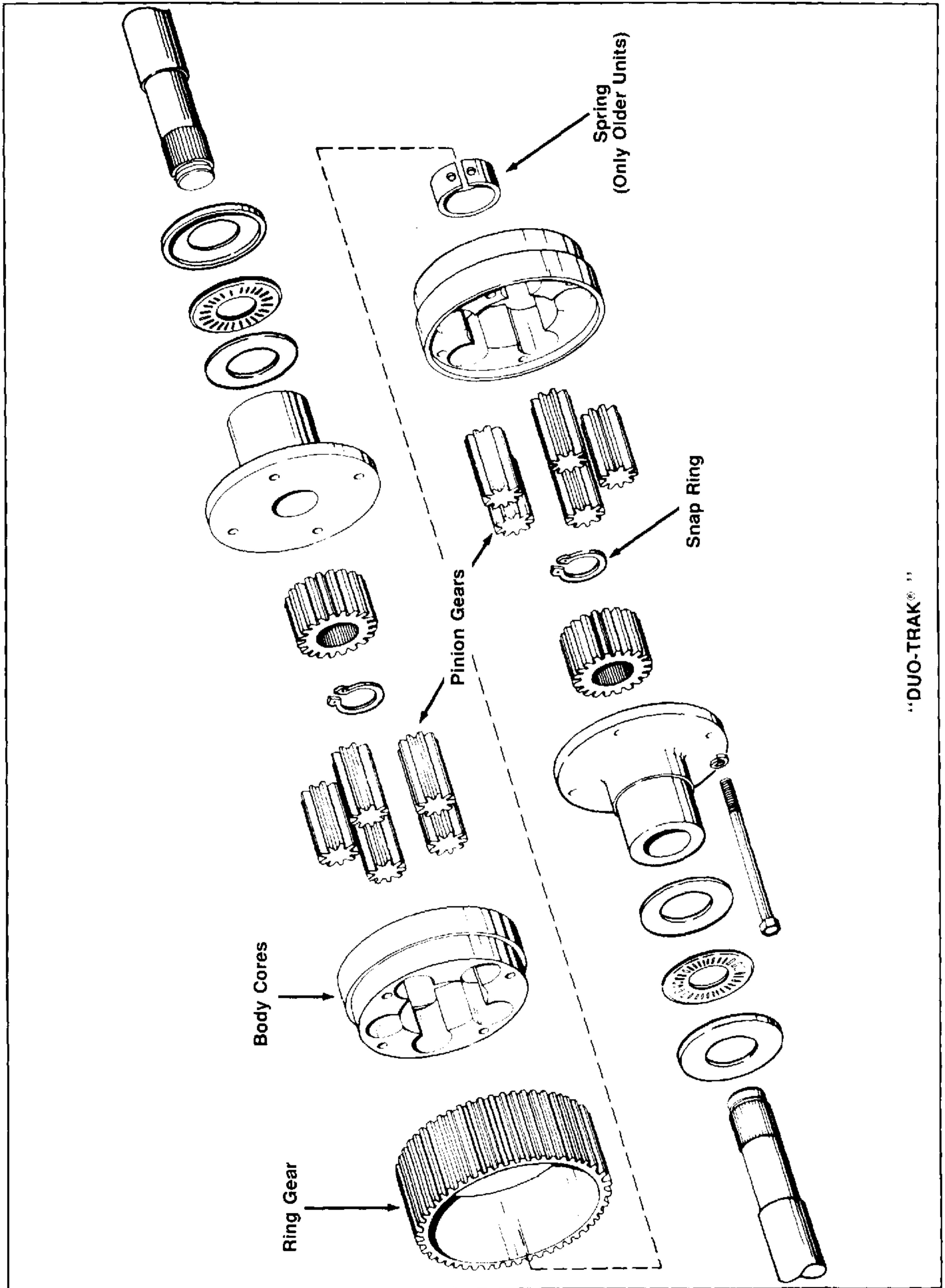

FIGURE 45.

BRAKE

(Model 805, 1105, 1215, 1605 and 1615)
Removal and Disassembly

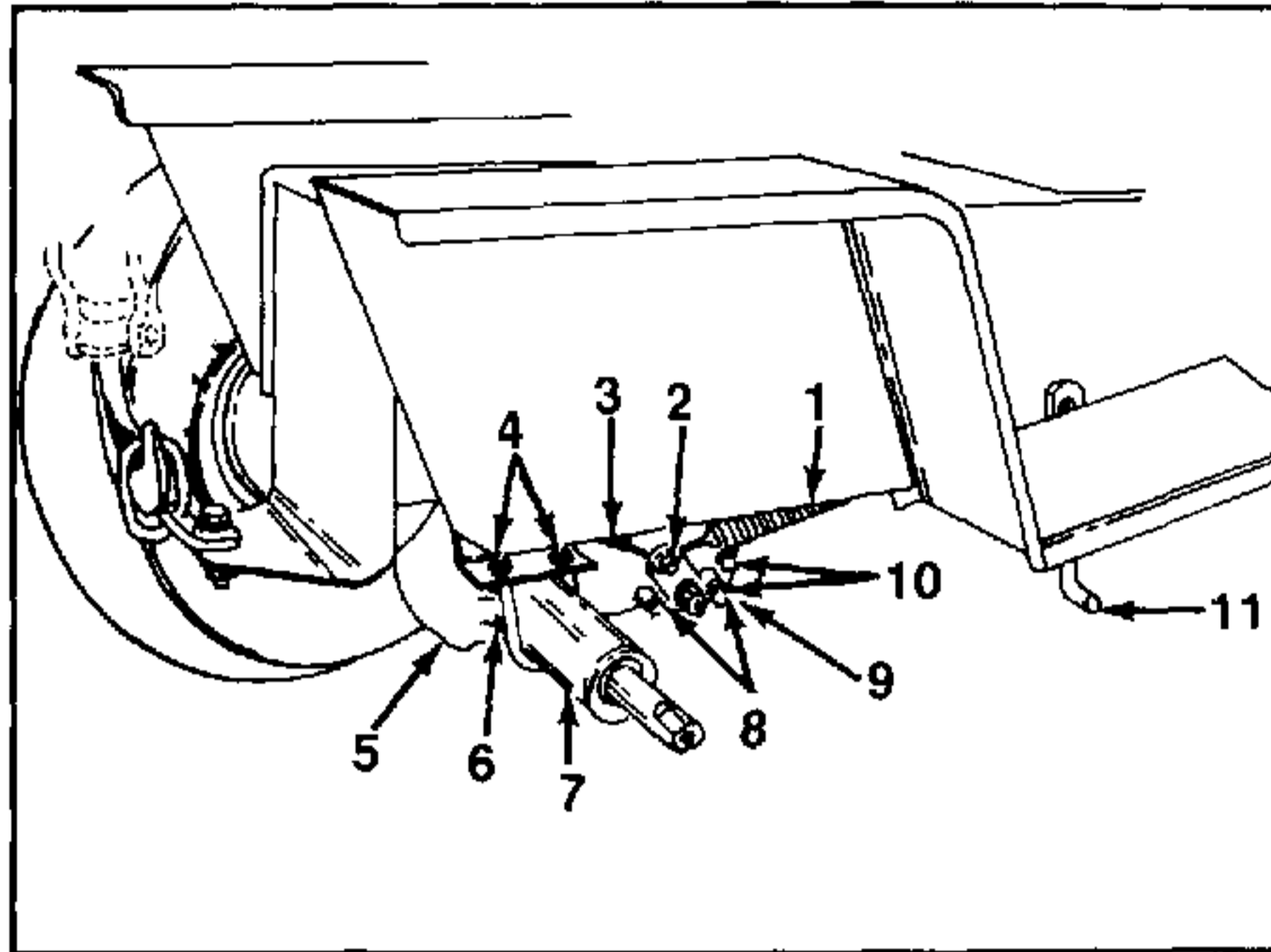

FIGURE 1.

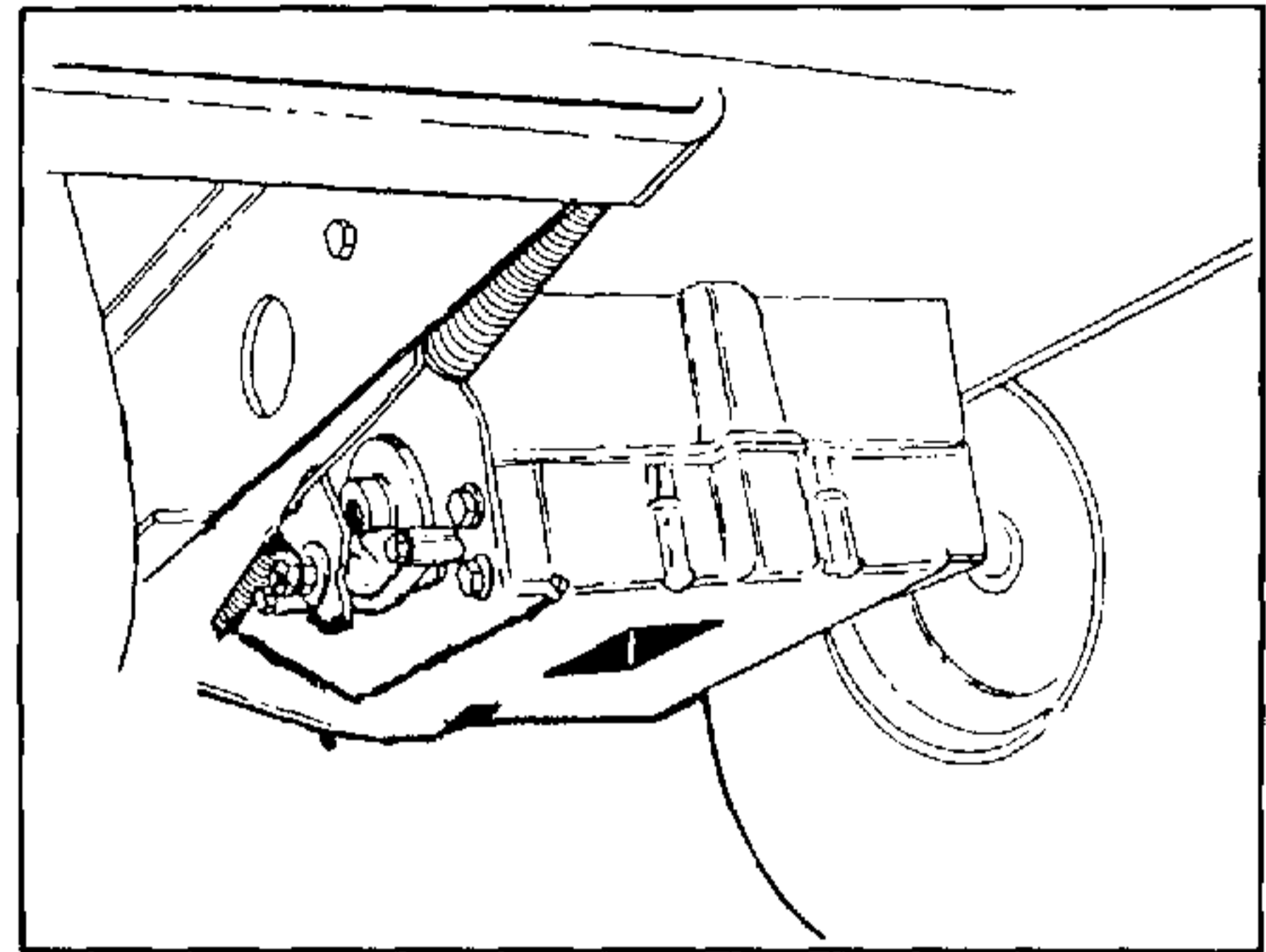

FIGURE 1A. (Model 1315, 1405, 1415 & 1715).

- | | |
|--|---|
| <ol style="list-style-type: none">1. Brake Rod Tension Spring2. Brake Lever3. Pull-Back Spring4. Transaxle Attaching Bolts5. Transaxle | <ol style="list-style-type: none">6. Brake Assembly7. Spacer8. Brake Attaching Bolts9. Transaxle Front Brace10. Transaxle Attaching Bolts11. Mower Lift Link Rod |
|--|---|

1. Set tractor on level work area. Position the shift lever in neutral position as indicated by the shift pattern plate on the tractor floor.
2. Raise the left rear of the tractor with a floor jack.
3. Pry off the hub cap from the left rear wheel. Remove the bolt and flat washers. Slide the wheel off of axle shaft.
4. Disconnect brake lever pull-back spring from hole in tractor frame.
5. With brake pedal in off position, remove two bolts attaching brake assembly to transaxle. Support brake assembly and unhook brake rod tension spring from brake lever. Outer brake pad, brake pad plate and dowels may fall out of brake assembly. Account for all parts.

6. Disconnect pull-back spring from brake lever.
7. Remove two nuts securing brake lever to brake pad holder stud. Separate lever from holder.
8. Slide brake disc from transaxle splined brake shaft. Remove inner brake pad.

INSPECTION AND REPAIR

1. Inspect all parts for wear, scoring, cracks, or breaks and replace as necessary.

REASSEMBLY AND INSTALLATION

1. Insert inner pad into recess provided in the transaxle casting. Coat disc splined bore with lubriplate and slip onto transaxle splined brake shaft to hold inner pad in position.

NOTE: Hub on brake disc faces outside of transaxle.

2. Lightly lubriplate parts and assemble brake lever to brake pad holder stud. Install washer and nut, but do not tighten adjusting nut.
3. Insert two dowel pins into brake pad holder bores. Position brake pad plate against dowel pins.
4. Supporting brake pad holder in one hand, hook brake rod tension spring into brake lever. Insert short bolt into front pad holder mounting hole and long bolt with spacer into rear pad holder mounting hole.
5. Insert outer brake pad over brake pad plate and position assembled unit in position on the transaxle. Align mounting bolts with holes in transaxle and tighten mounting bolts.
6. Hook pull-back spring in hole of brake lever and attach to hole in tractor frame.
7. Adjust brakes to disengage when clutch is engaged.
8. Check for binding by turning axle shaft.

NOTE: To secure brake lever, hold bottom nut and torque top nut to 100 in. lbs.

9. Install rear wheel, then lower tractor.

ADJUSTING THE BRAKES

During normal operation of this machine, the brakes are subject to wear and will require periodic examination and adjustment.

To check the brake adjustment, place the gear shift lever in neutral ("N") position; lock the parking brake. You should not be able to push the tractor.

If the tractor can be pushed with the parking brake locked, or if the unit cannot be pushed with the parking brake released, brake adjustment is necessary.

To adjust the brake, proceed as follows. (See Figure 2.)

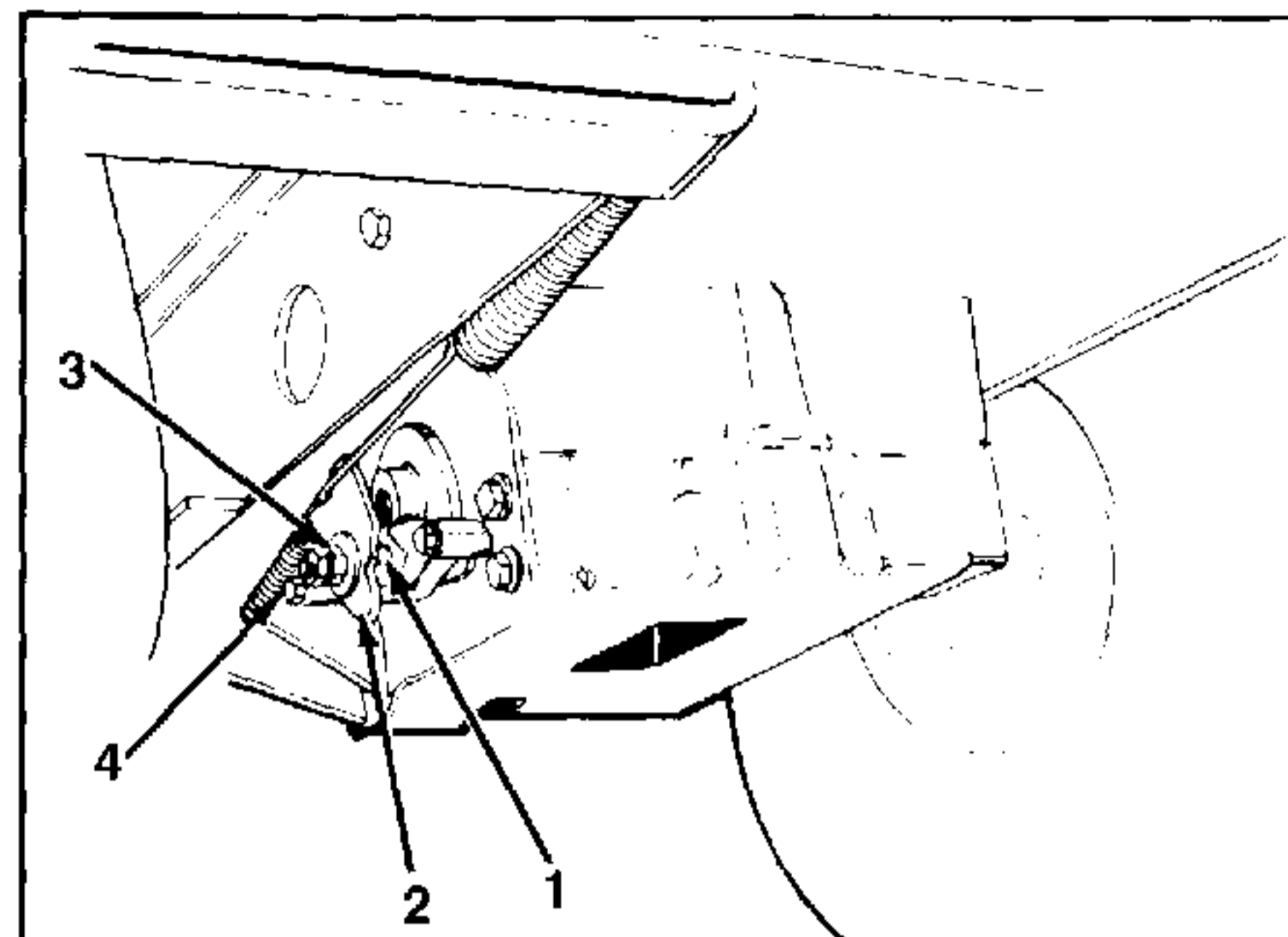

FIGURE 2.

1. Stop Bolt
2. Cam Lever
3. Inside Bolt
4. Outside Bolt

1. Tighten the inside nut until the cam lever cannot be moved by hand.
2. Loosen the inside nut until the cam lever can be pushed forward so that there is a 1/8 inch to 3/16 inch space between the cam lever and stop bolt.
3. Tighten the outside nut against the inside nut, using two 1/2 inch wrenches.
4. If there is not more adjustment left at the two nuts, tighten the hex nut on the end of the brake rod, under the spring. Remove the hairpin cotter and clevis pin from the other end of the brake rod to disconnect it, and tighten the nut.

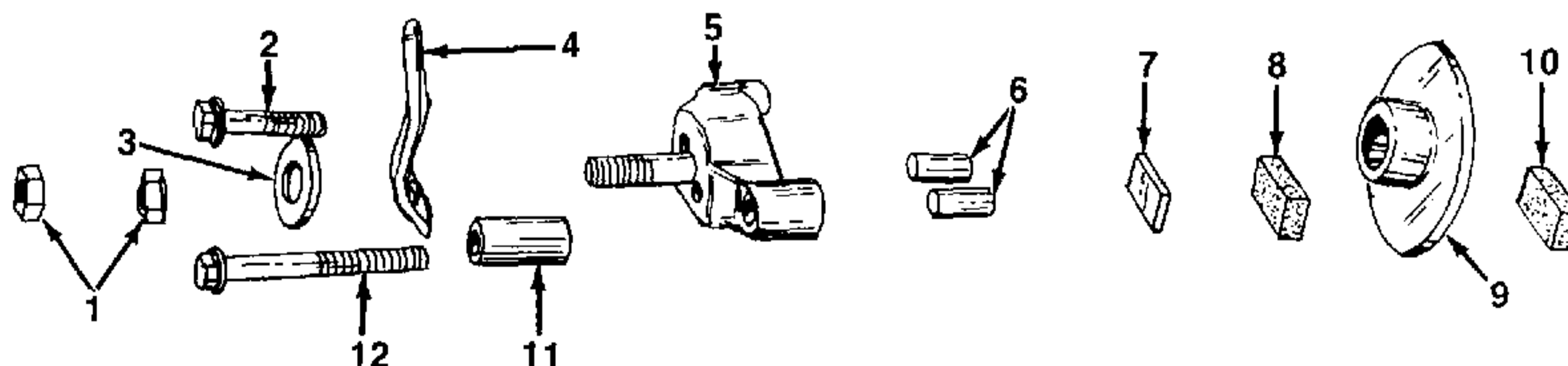

FIGURE 3.

1. Adjusting Nuts	7. Brake Pad Plate
2. Short Mounting Bolt	8. Brake Pad
3. Washer	9. Brake Disc
4. Brake Lever	10. Brake Pad
5. Brake Pad Holder	11. Spacer
6. Dowel Pins	12. Long Mounting Bolt

HYDROSTATIC TRANSMISSION

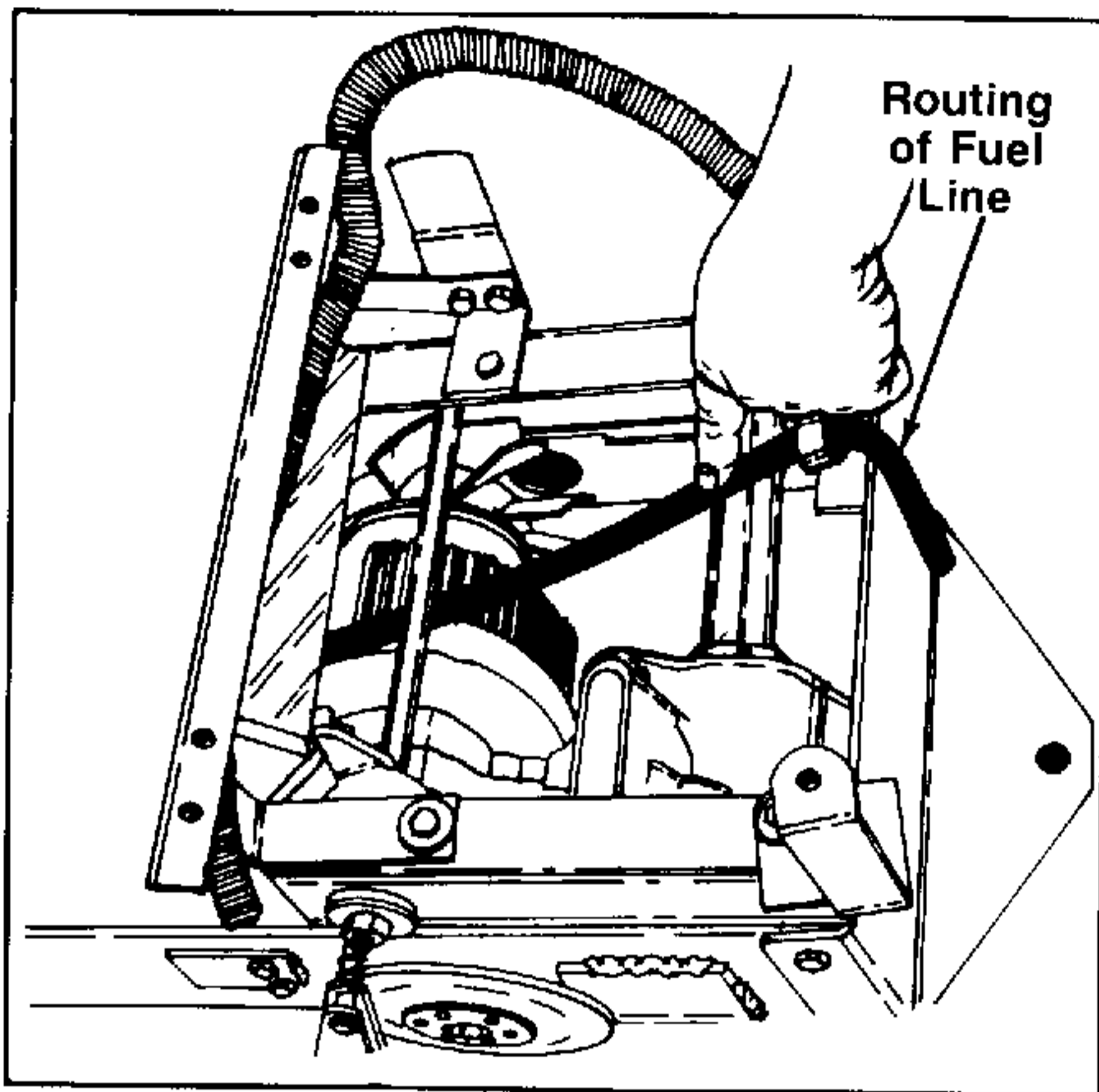

FIGURE 1.

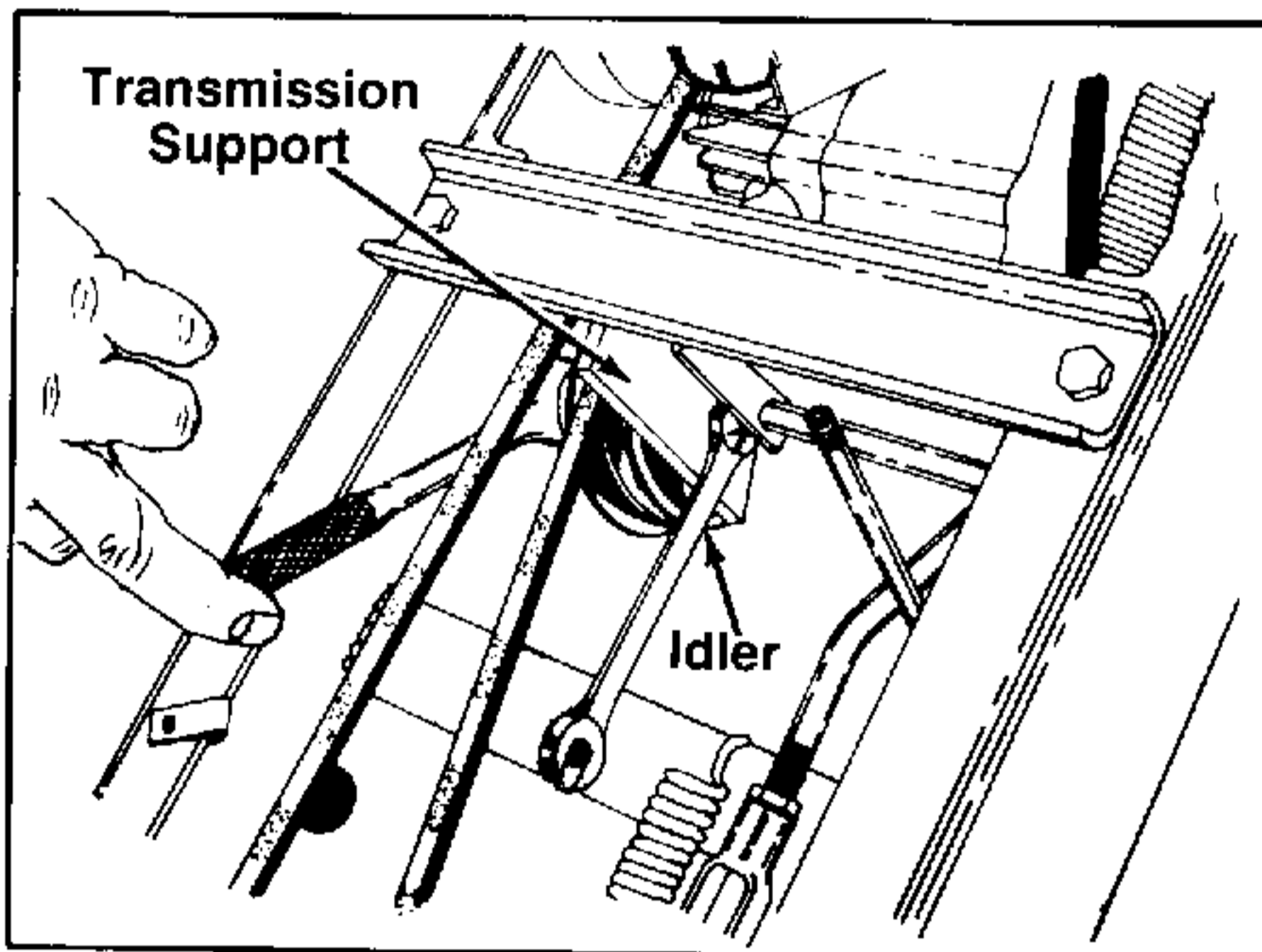

FIGURE 2.

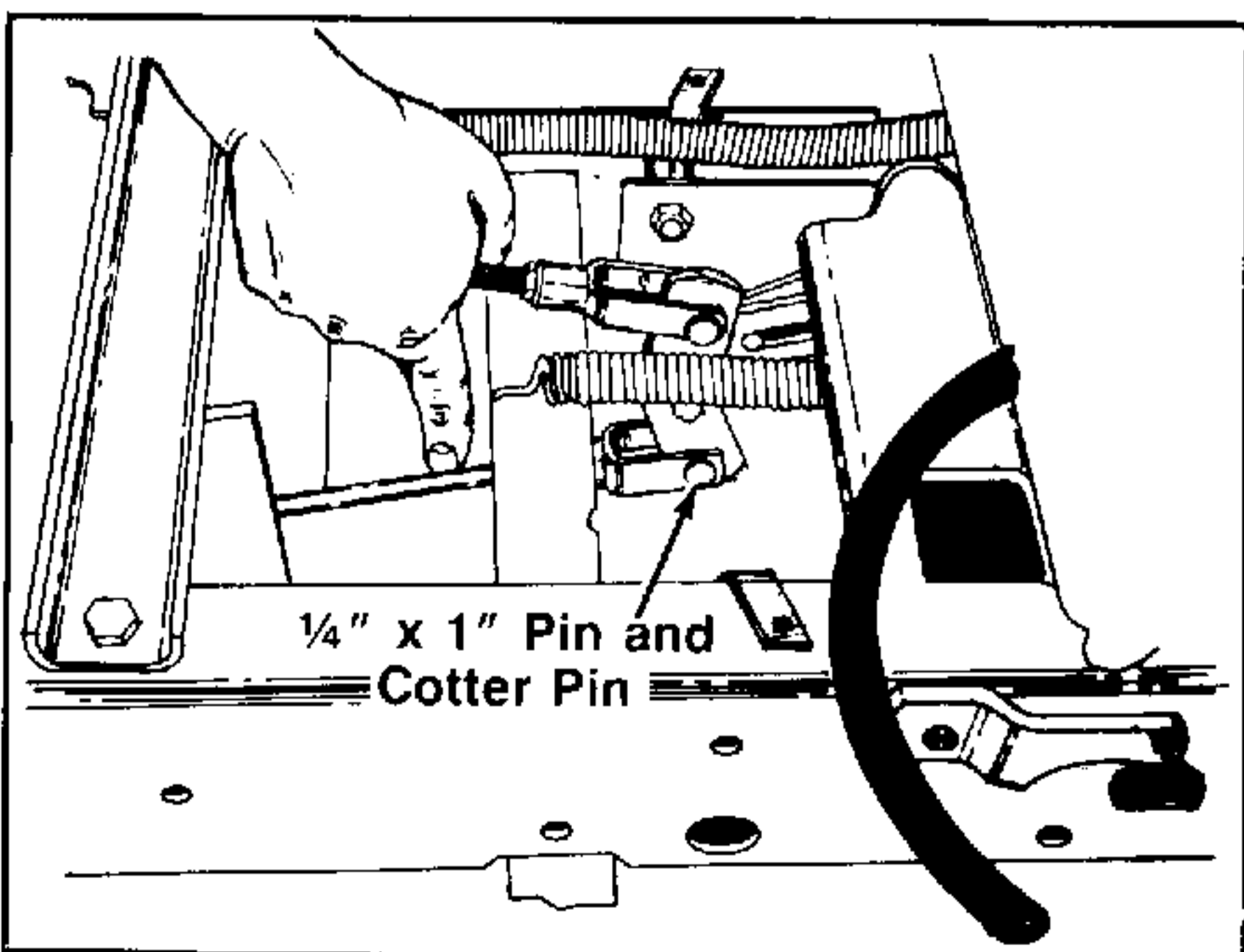

FIGURE 3.

REMOVAL

1. Remove fender and fuel tank. Refer to section 2, page 10, figures 1, 2, 3, 4 and 5.
2. Check the routing of fuel line, take loose back at the steering pedestal and put off to one side for now. See figure 1.

3. Remove the drive belt.

NOTE: Idler is secured to bracket which supports the front of transmission with 3/8" x 1 1/2" bolt and self-locking nut. See figure 2. Remove belt with the transmission, by first removing the P.T.O. drive. Refer to section 1, page 6, figure 15.

4. Remove hydrolinkage at pivot bracket, by removing 1/4" x 1" pin and cotter pin. See figure 3.

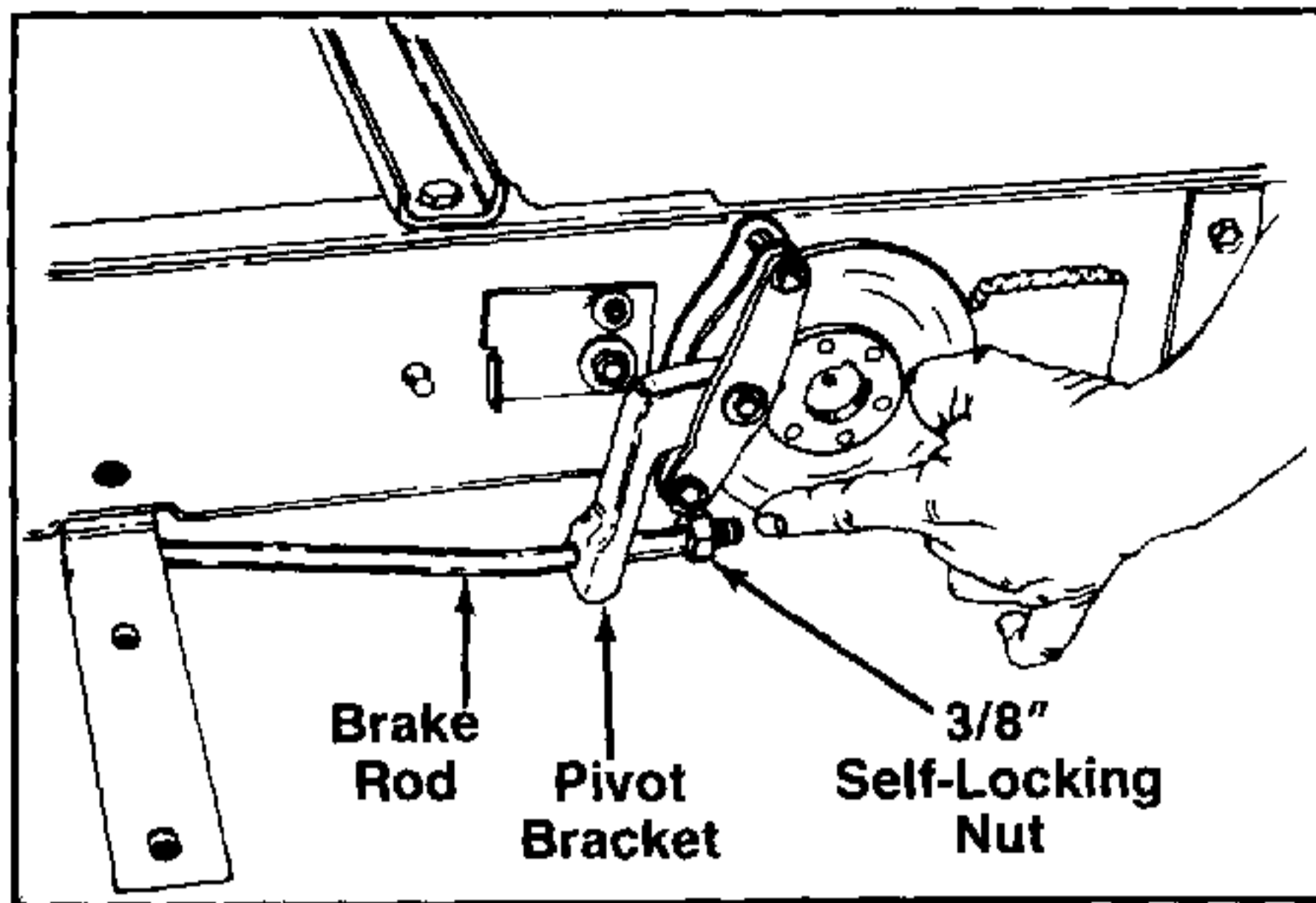

FIGURE 4.

5. Remove brake rod by loosening the 3/8" self-locking nut.

NOTE: The other end of brake rod can remain hooked to the tractor.

NOTE: Rear wheel was removed in figure 4 for clarity, it is not necessary to remove.

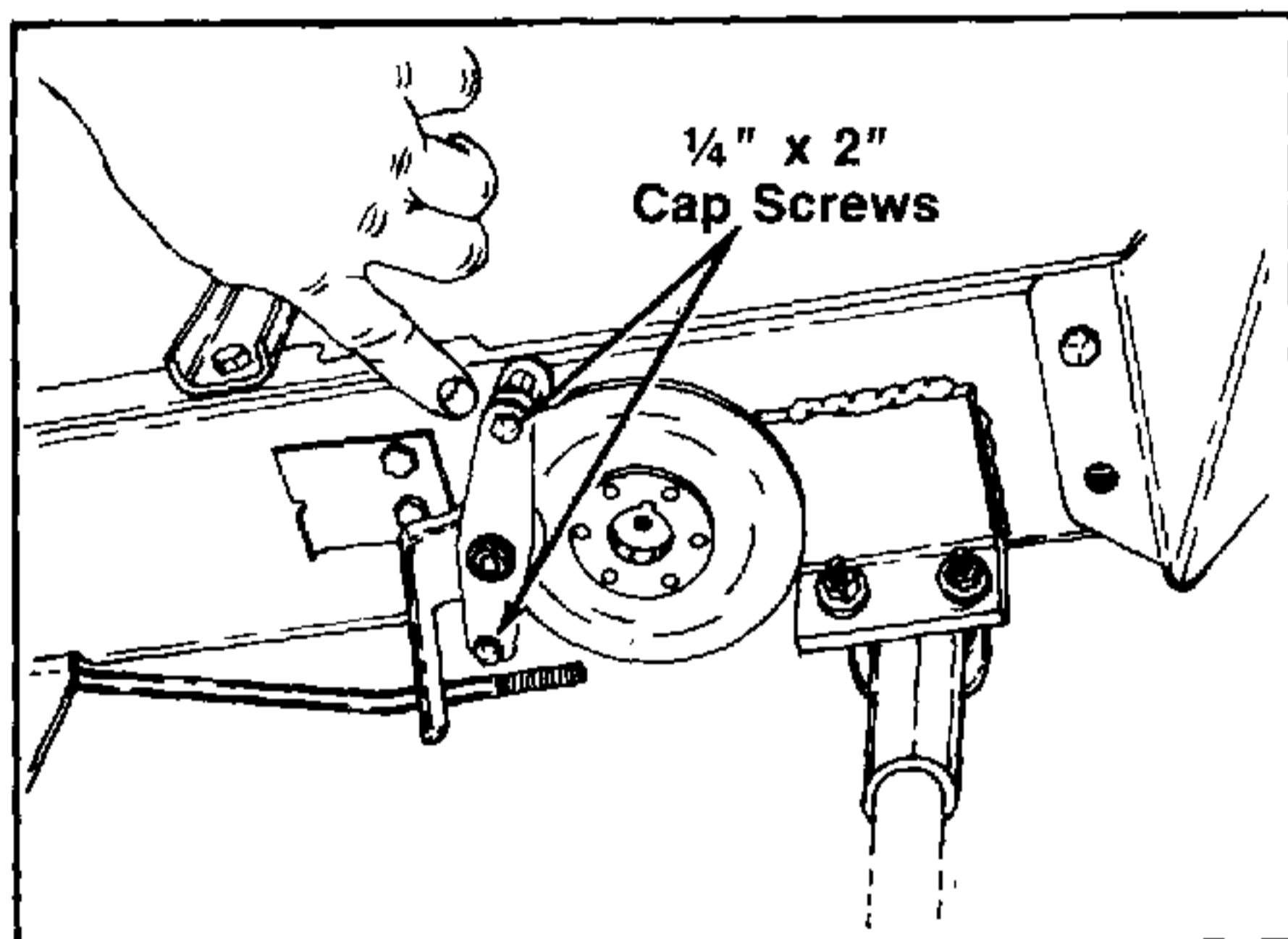

FIGURE 5.

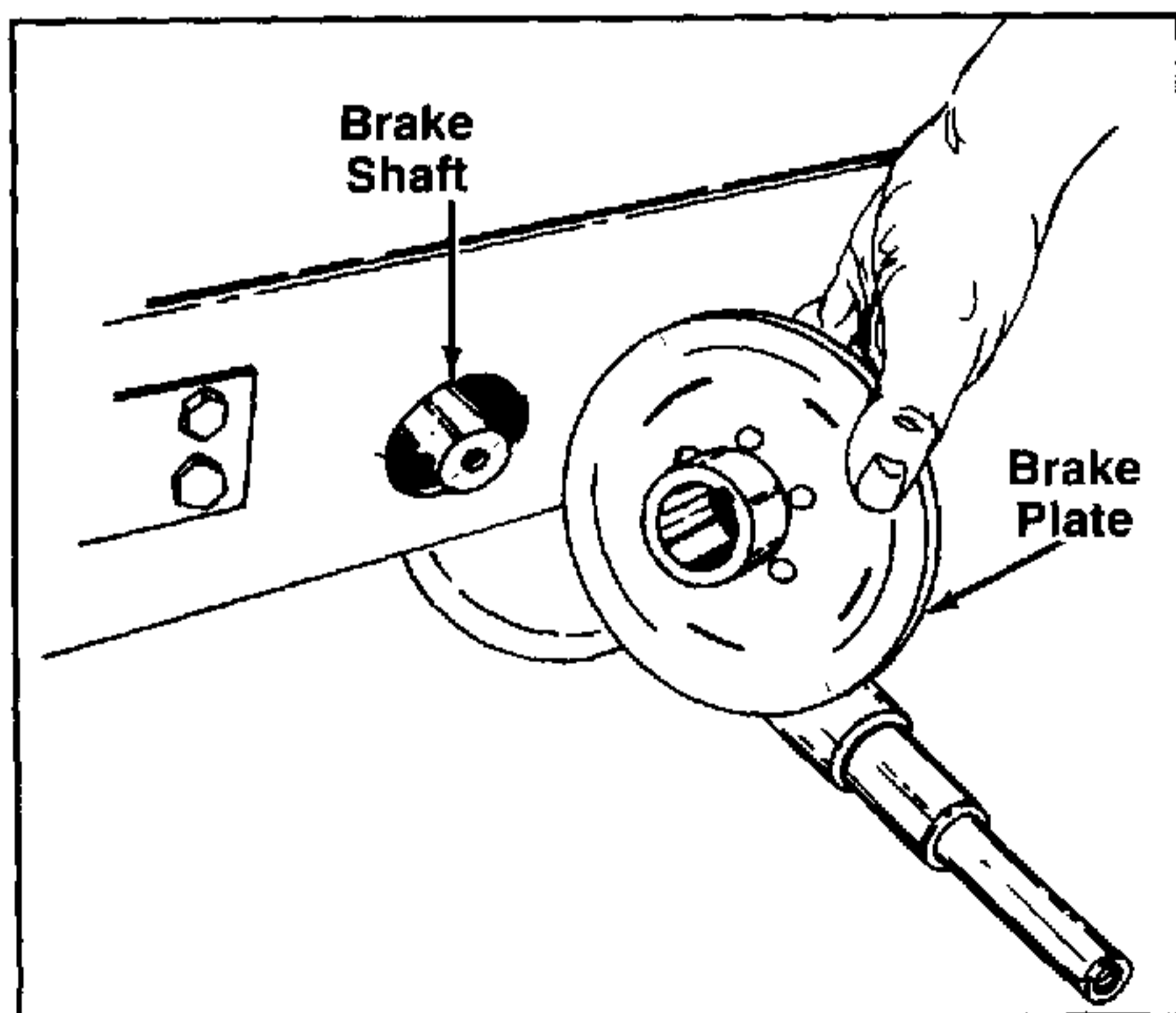

FIGURE 6.

6. Remove brake assembly, by removing two 1/4" x 2" long cap screws and lay off to one side. See figure 5.

NOTE: The brake plate can now be removed by sliding it off of the brake shaft. See figure 6.

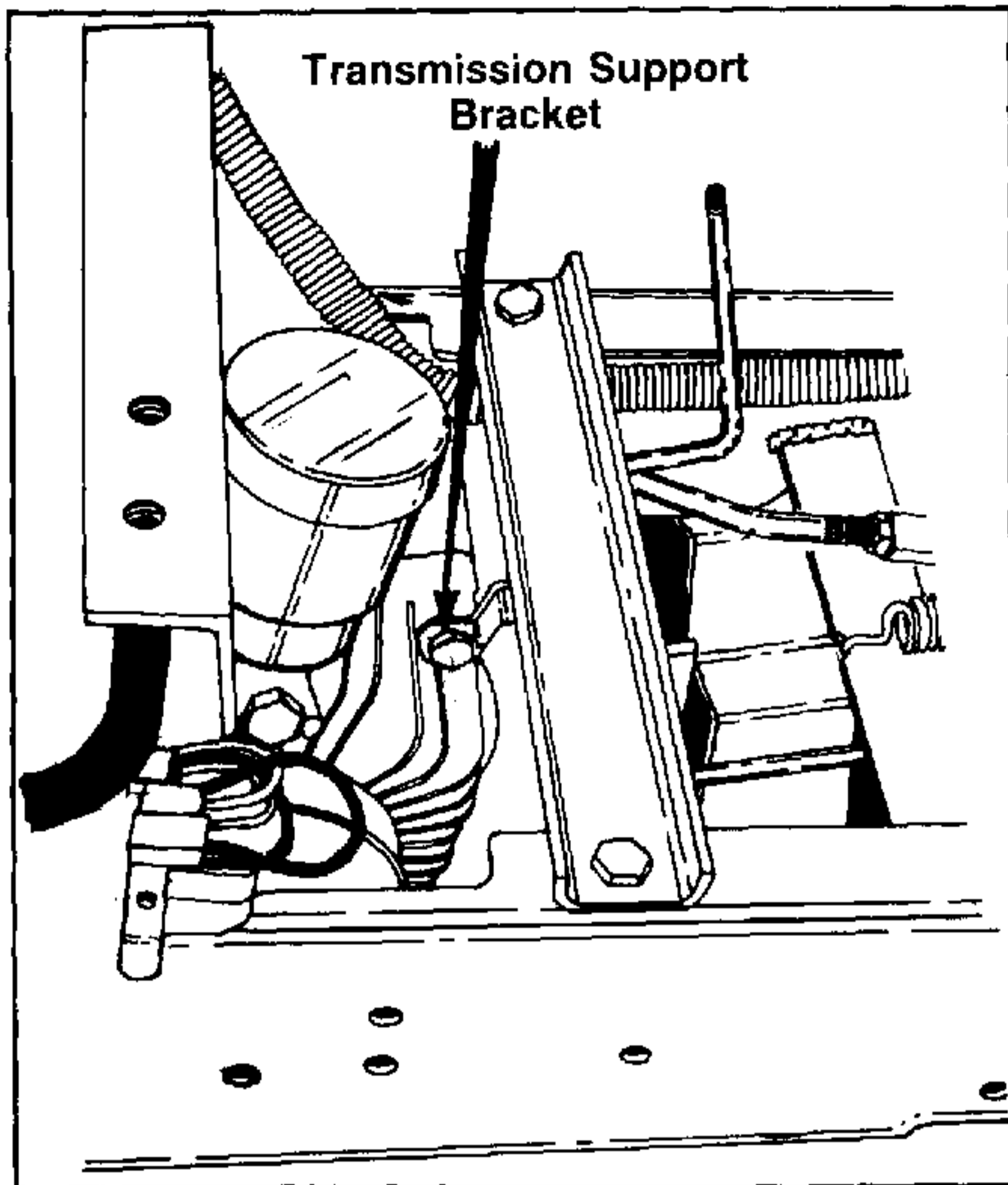

FIGURE 7.

7. Remove transmission support bracket, by removing two 3/8" x 1" cap screws and nuts. See figure 7.

NOTE: This bracket supports the front of the transmission. You will need to remove the two front transmission bolts to take the bracket completely off. See figure 7.

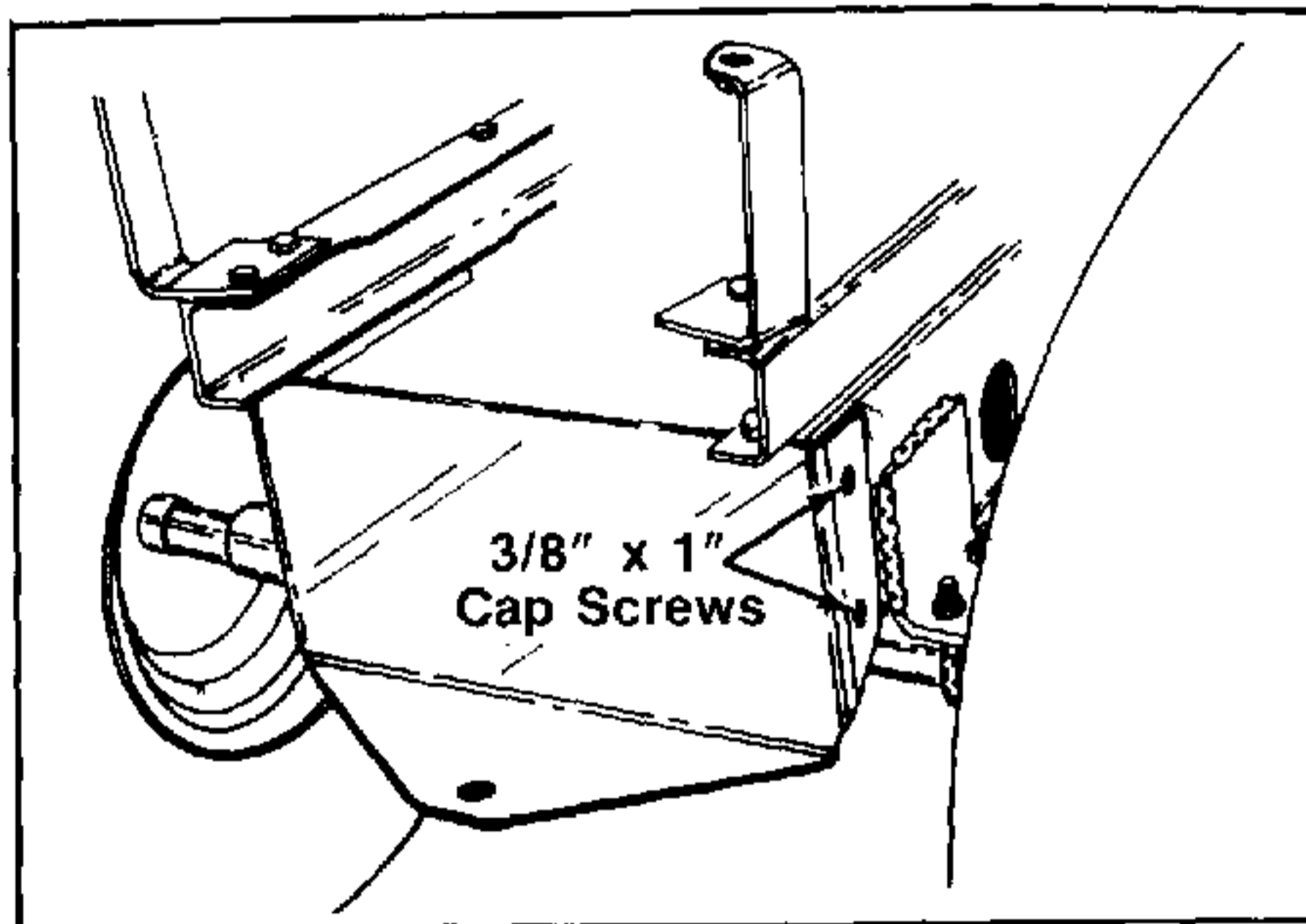

FIGURE 8.

8. Remove the rear hitch plate by removing the four 3/8" x 1" cap screws and lock washers. See figure 8.

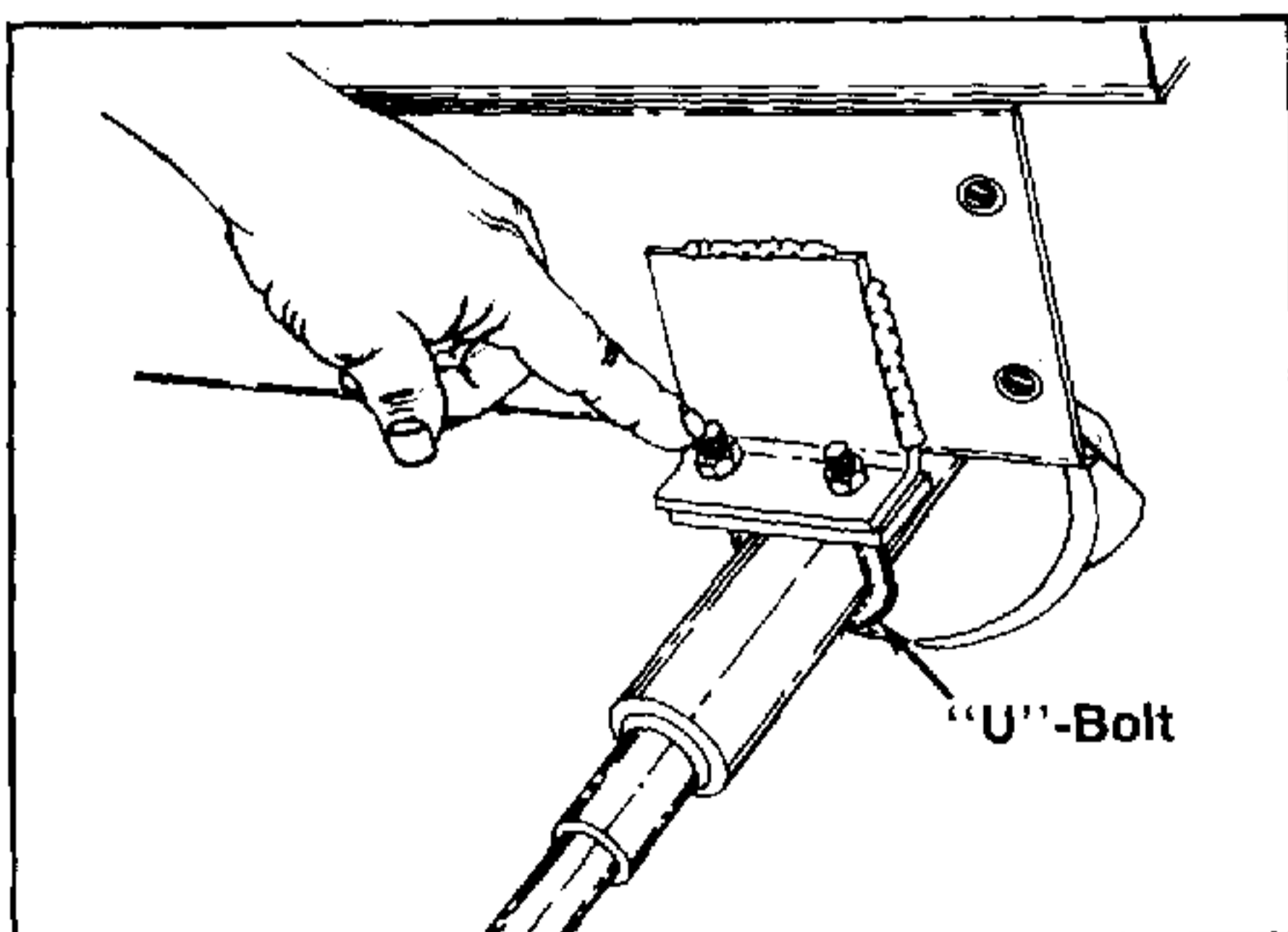

FIGURE 9.

9. Lift the rear of tractor so the rear wheels clear the ground and support the tractor with jackstands.
10. Remove the two "U"-Bolts that retain the final drive housing to the frame of the tractor. See figure 9.

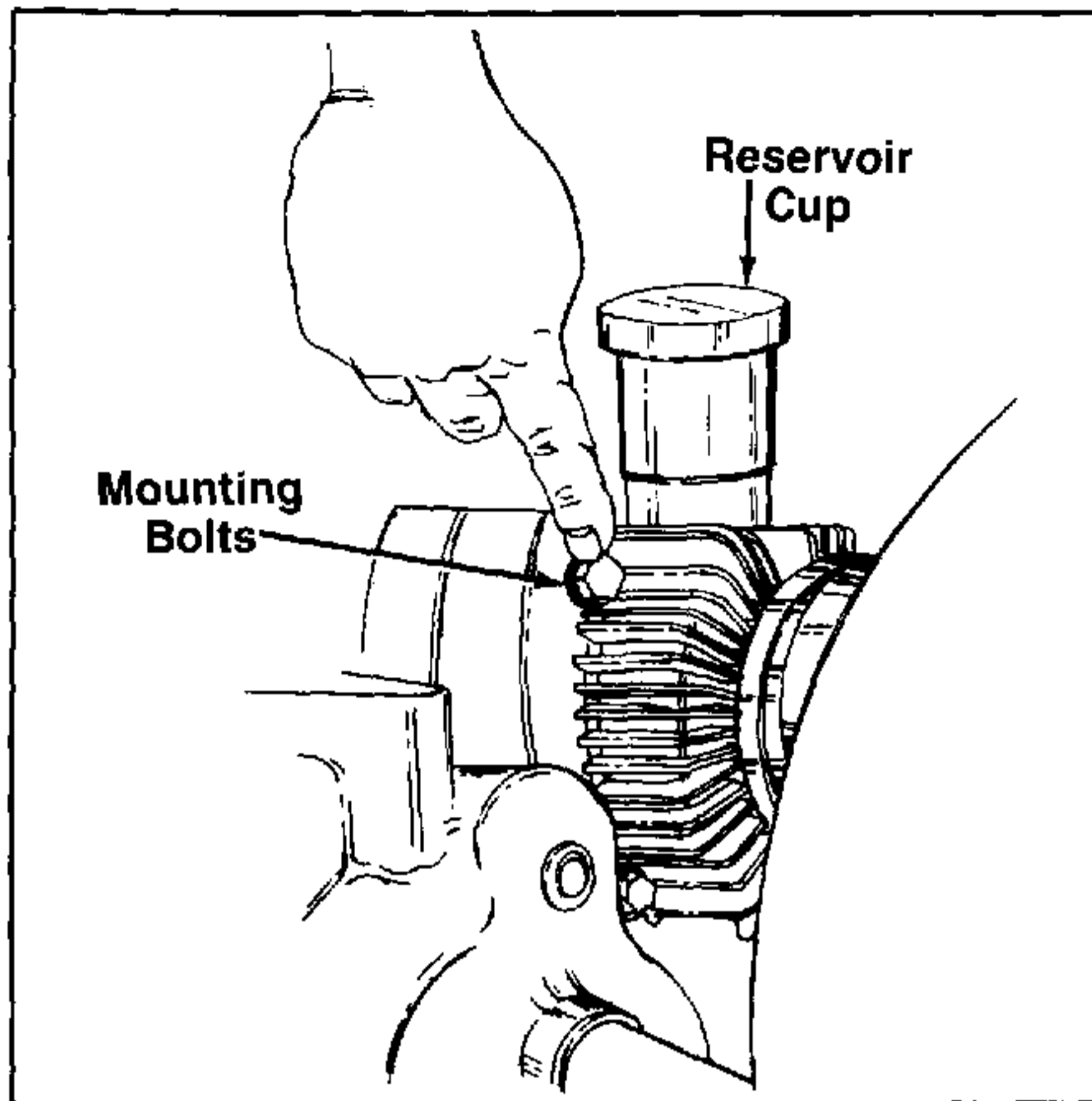

FIGURE 10.

11. Back final drive housing out from under frame of tractor.

NOTE: BE CAREFUL NOT TO DAMAGE TRANSMISSION RESERVOIR CUP. See figure 10.

12. Remove the transmission from the final drive housing, by removing the two remaining mounting bolts. See figure 10.

INSTALLATION

1. Install transmission by reversing the removal procedure.
2. Make sure drive belts and any parts removed are correctly adjusted and tightened.

EATON HYDROSTATIC TRANSMISSION ADJUSTMENTS

1. Jack up rear of tractor to bring drive tires off of ground. **NOTE:** Be sure and block tractor with jack stands.
2. Start engine and move *S/R lever back and forth until true neutral is obtained. When true neutral has been determined, leave S/R lever at that point and turn off engine.
3. Remove the cotter pin and headed pin that retains transmission linkage to pivot arm. See figure 1. **NOTE:** Be sure transmission lever, attached to hydrostatic transmission, does not move.

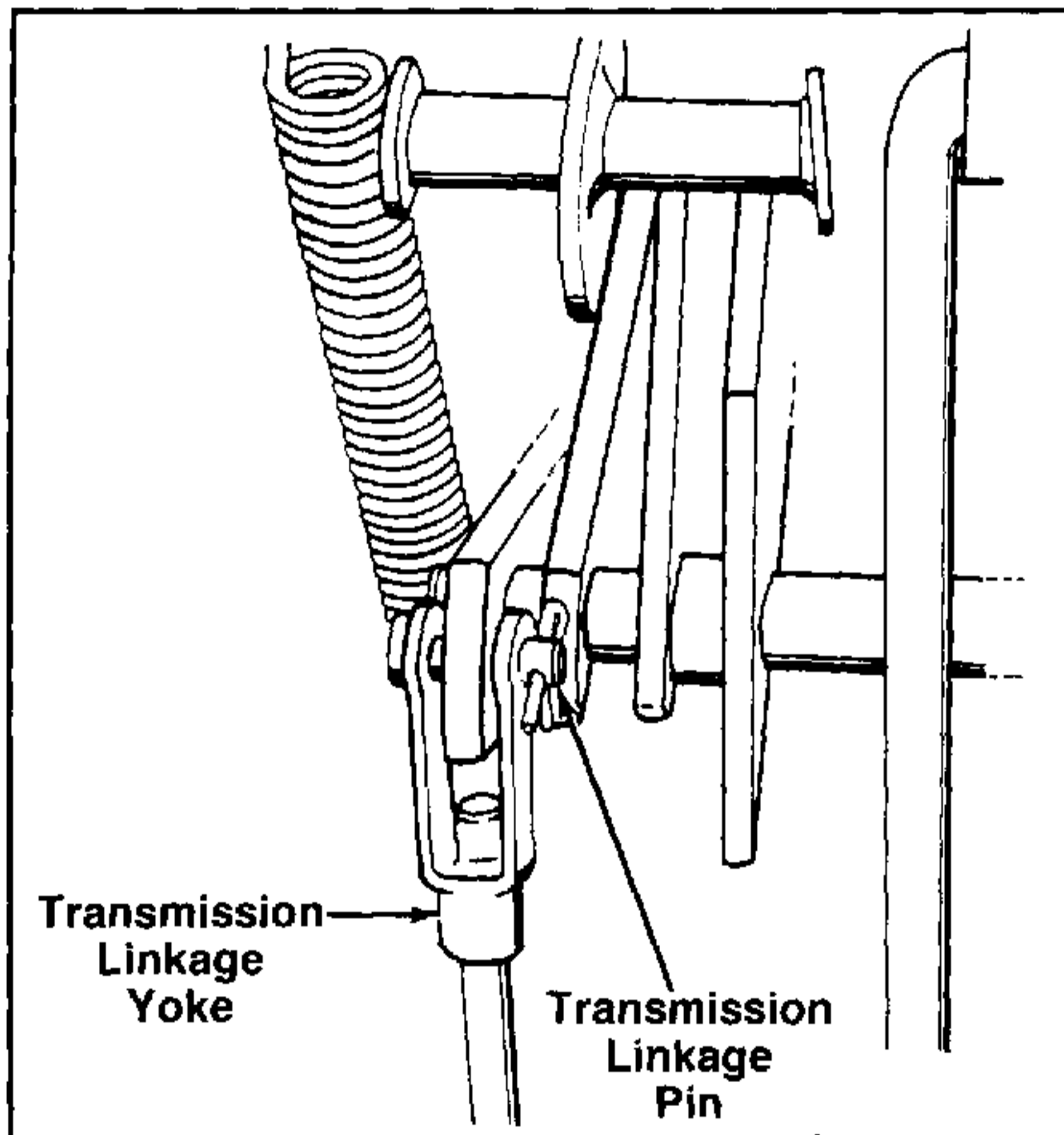

FIGURE 1.

4. Move S/R lever to forward position. Push down on brake pedal to bring S/R lever back to neutral. If it does not return to neutral, proceed as follows. **NOTE:** If S/R lever tries to move into reverse proceed to step 9.
5. Remove cotter pin and headed pin that retains S/R lever linkage to pivot arm. See figure 2.
6. Lengthen S/R lever linkage by adjusting yoke on end of linkage.
7. Reattach S/R lever linkage to pivot arm. **NOTE:** Do not install cotter pin at this time.
8. Move S/R lever to forward position and push down on brake pedal to bring S/R lever back to neutral. If S/R lever does not return to neutral continue to lengthen S/R lever linkage until neutral can be obtained when stepping down on brake pedal.
9. Move S/R lever to reverse and push down on brake pedal. S/R lever should go to neutral. If S/R lever does not return to neutral, proceed as follows:

10. Remove headed pin that retains S/R lever linkage to pivot arm. See figure 2.

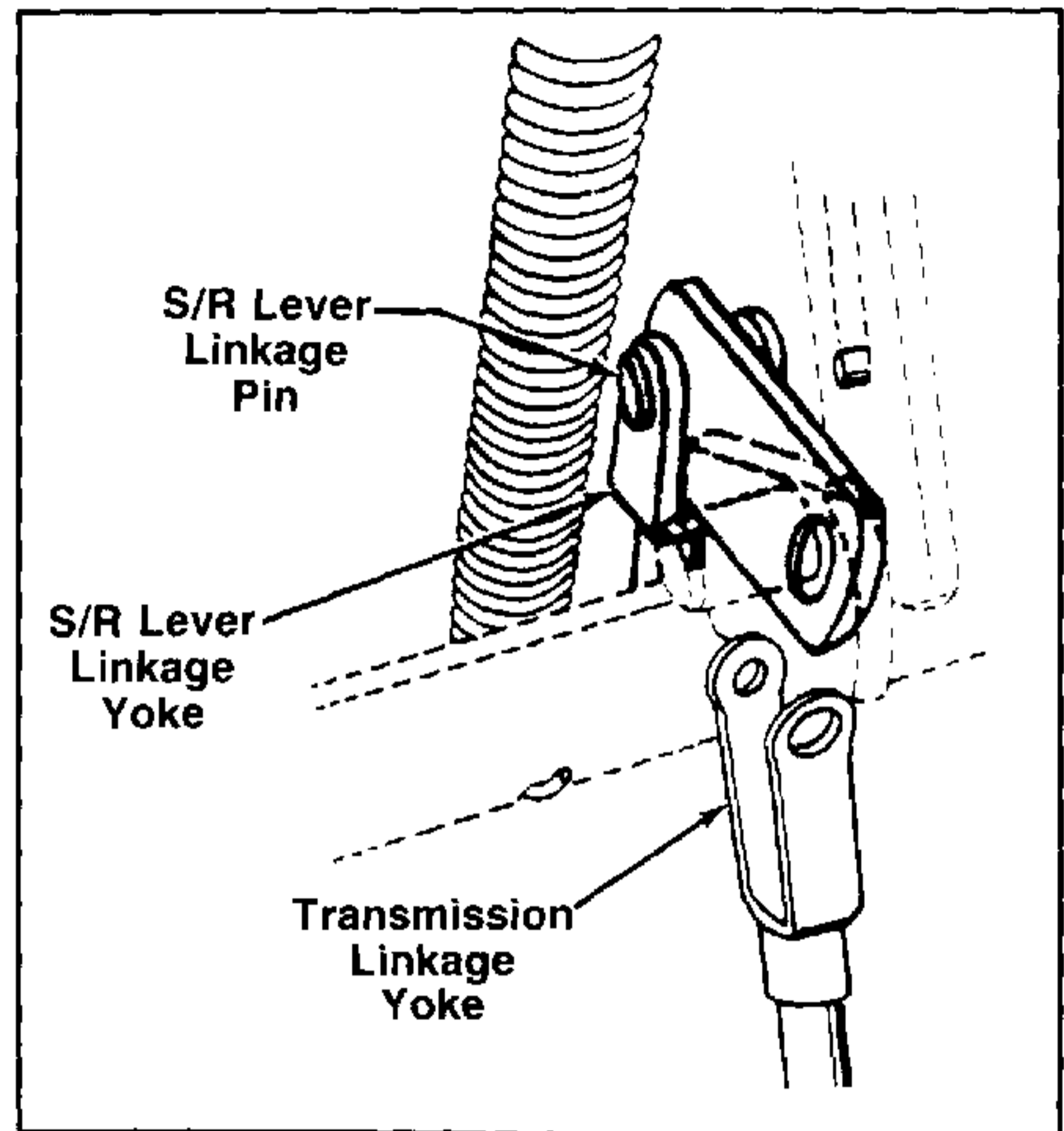

FIGURE 2.

11. Shorten S/R lever linkage by turning adjusting yoke on end of linkage.
12. Reattach S/R lever linkage to pivot arm. **NOTE:** Do not install cotter pin at this time.
13. Move S/R lever to reverse and push on brake pedal. S/R lever should return to neutral.
14. Recheck to be sure S/R lever returns to neutral when placed in forward position and the brake pedal pushed down. If S/R lever does not return to neutral, you should adjust accordingly. **NOTE:** At this time the cotter pin should be installed to retain the headed pin in the S/R lever linkage.
15. Making sure S/R lever is in neutral and transmission lever has not moved, adjust the yoke on the transmission lever linkage, see figure 1, until pin can be installed in transmission lever yoke and transmission lever without interference.
16. Install cotter pin in headed pin that retains transmission linkage to the pivot bracket.
17. Remove tractor from safety stands and drive tractor. Make sure that S/R lever returns to neutral, when brake pedal is pushed down, and tractor does not move forward or reverse. **NOTE:** If tractor still moves, when brake pedal is pushed down, recheck all adjustments.
18. Be sure all linkage is retained properly with cotter pins or quick pins.

*S/R same as control lever.

DISASSEMBLY/REASSEMBLY

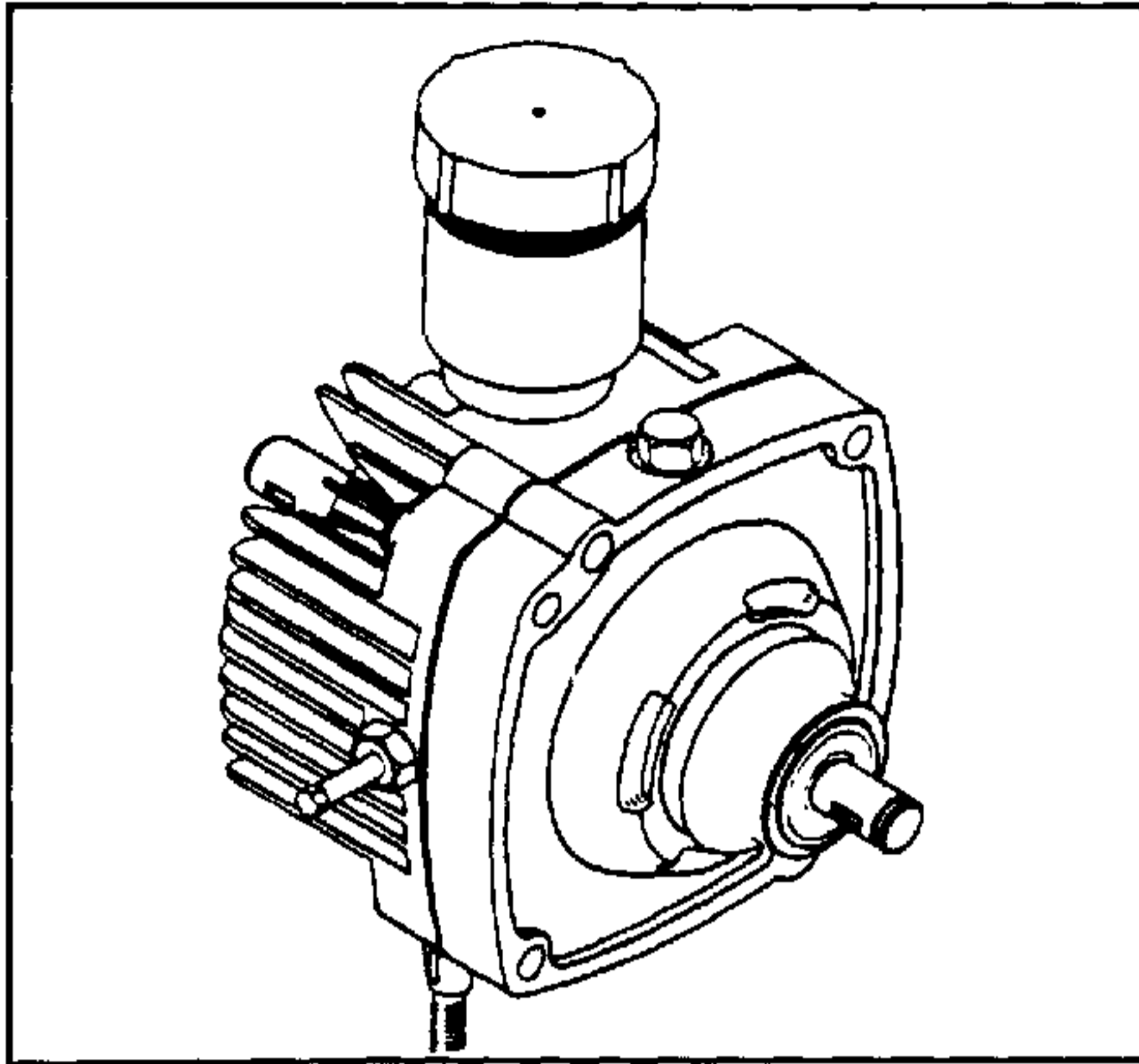

FIGURE 1.

Clean the transmission exterior thoroughly before repairs are begun. Use a cleaning solution that will not affect paint, gaskets, rubber seals, and plastic.

Important: When compressed air is used in cleaning, do not expose lip seals or bearing surfaces to high pressure.

Drain fluid from transmission.

Note: A 2" x 6" x 10" wooden block with a 3/4 inch hole in the center is recommended for a suitable bench fixture.

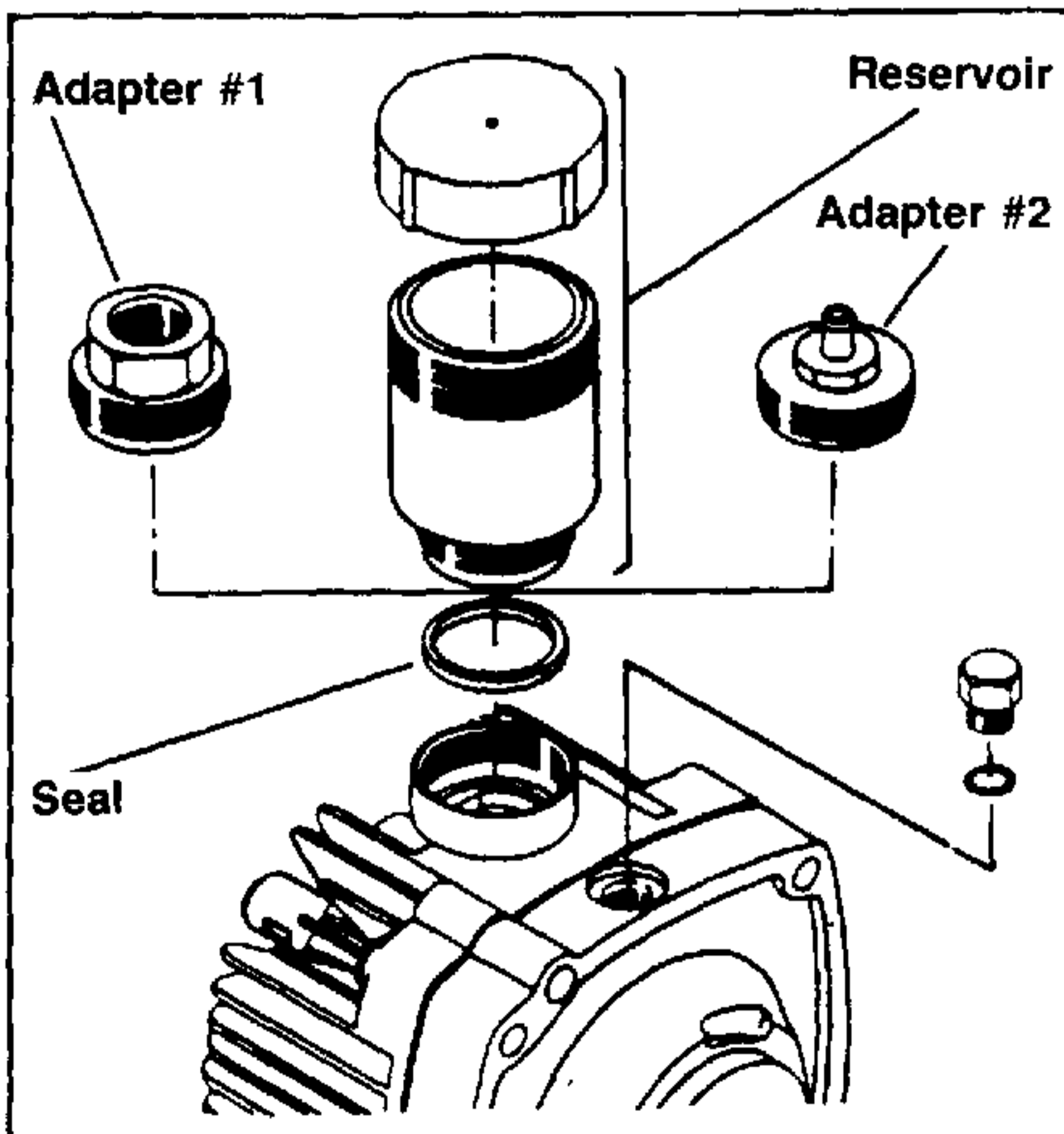

FIGURE 2.

RESERVOIR/ADAPTER—DISASSEMBLY

Eaton light duty transmissions are equipped with one of two adapters or a reservoir as shown in figure 2.

1. Remove the adapter or reservoir by rotating clockwise.

Important: The adapters and reservoir have left hand threads. To remove turn clockwise.

To remove adapter #1 use a six point 1 1/2" hex wrench or socket.

To remove adapter #2 use a six point 1" hex wrench or socket.

To remove the reservoir use a small filter or web wrench.

2. Remove the seal ring from the cover and discard.

Note: We recommend that all seals be replaced with new ones whenever the transmission is disassembled and reassembled.

BODY/COVER—DISASSEMBLY

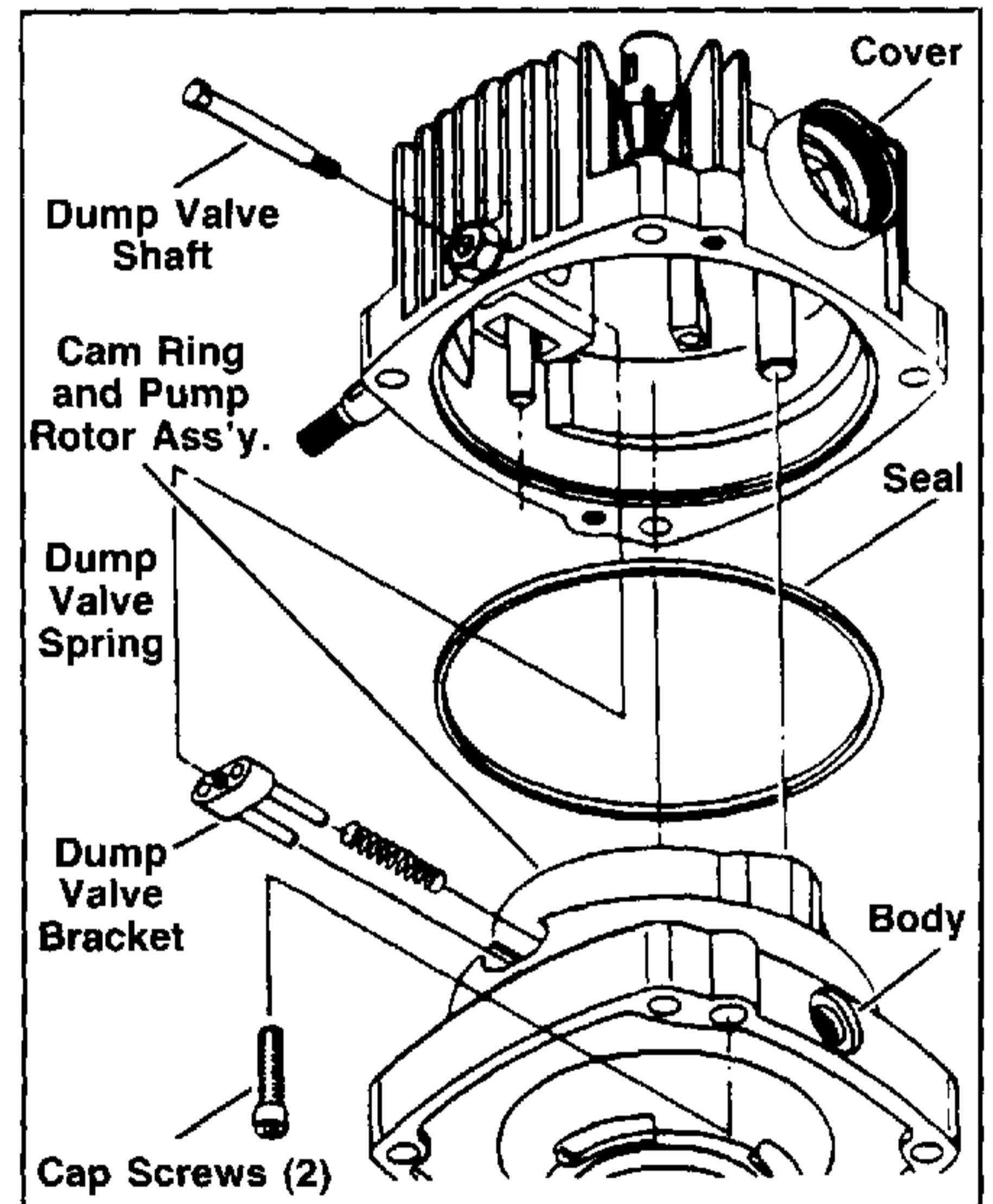

FIGURE 3.

Important: Before disassembling the transmission, scribe a line across the cover and body to ensure correct reassembly. Incorrect assembly will change output shaft rotation.

3. Use 1/4 inch Allen wrench to remove the (2) 5/16 cap screws. Where applicable, remove the dump valve shaft.
4. Lift the cover to separate from the body.

Important: Do not allow the cam ring, pintle, or pump rotor assembly to lift the cover. The pump ball piston assembly must remain intact as the ball pistons are matched to the pump rotor bores.

If the cover does not separate easily from the body because of fluid seal, tap the body and/or cover with plastic hammer to break the seal.

5. Remove the dump valve bracket, and springs, when used.
6. Remove the seal ring and discard.

COVER—DISASSEMBLY

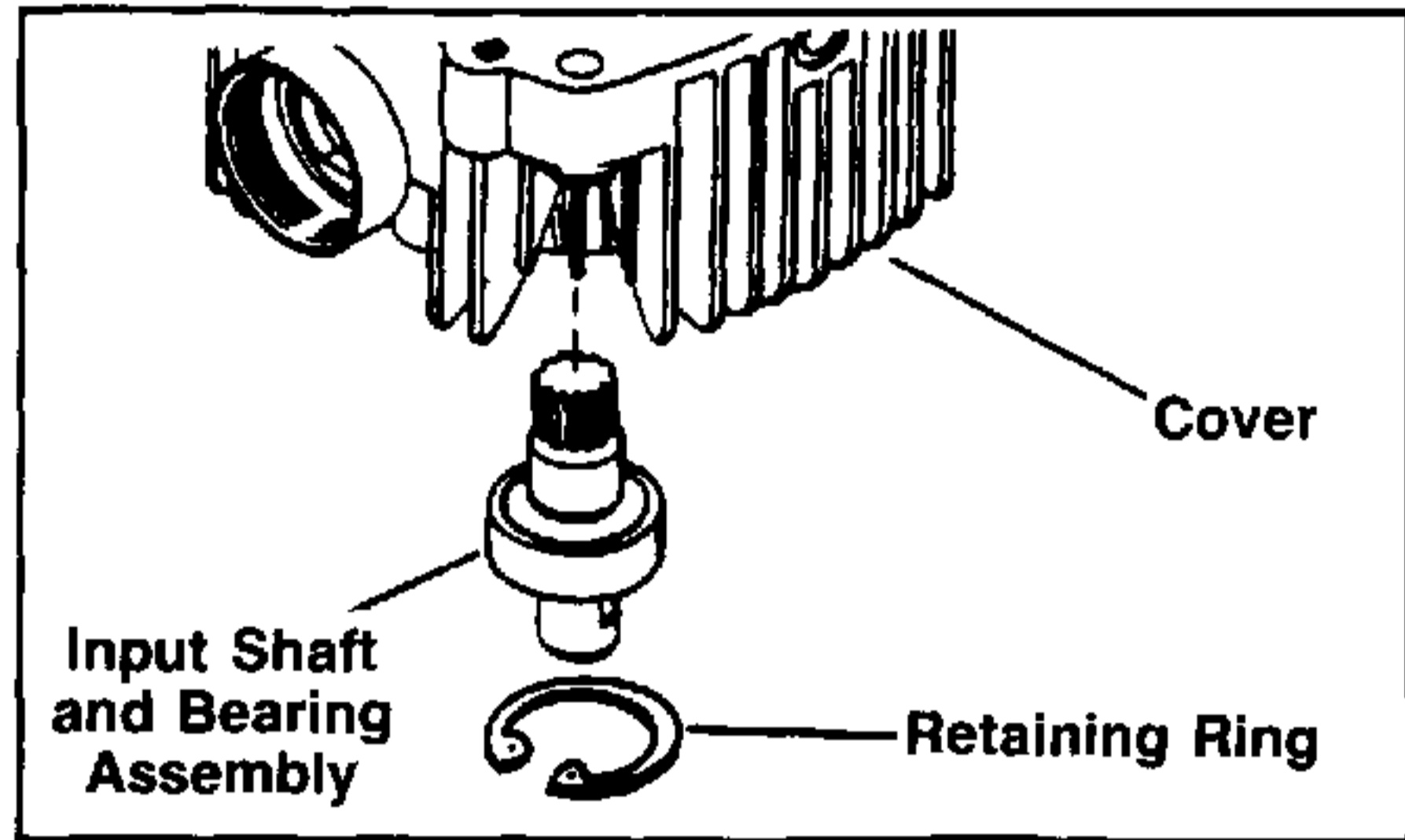

FIGURE 4.

7. Remove input shaft retaining ring. Press or drive the input shaft and bearing assembly from the cover.

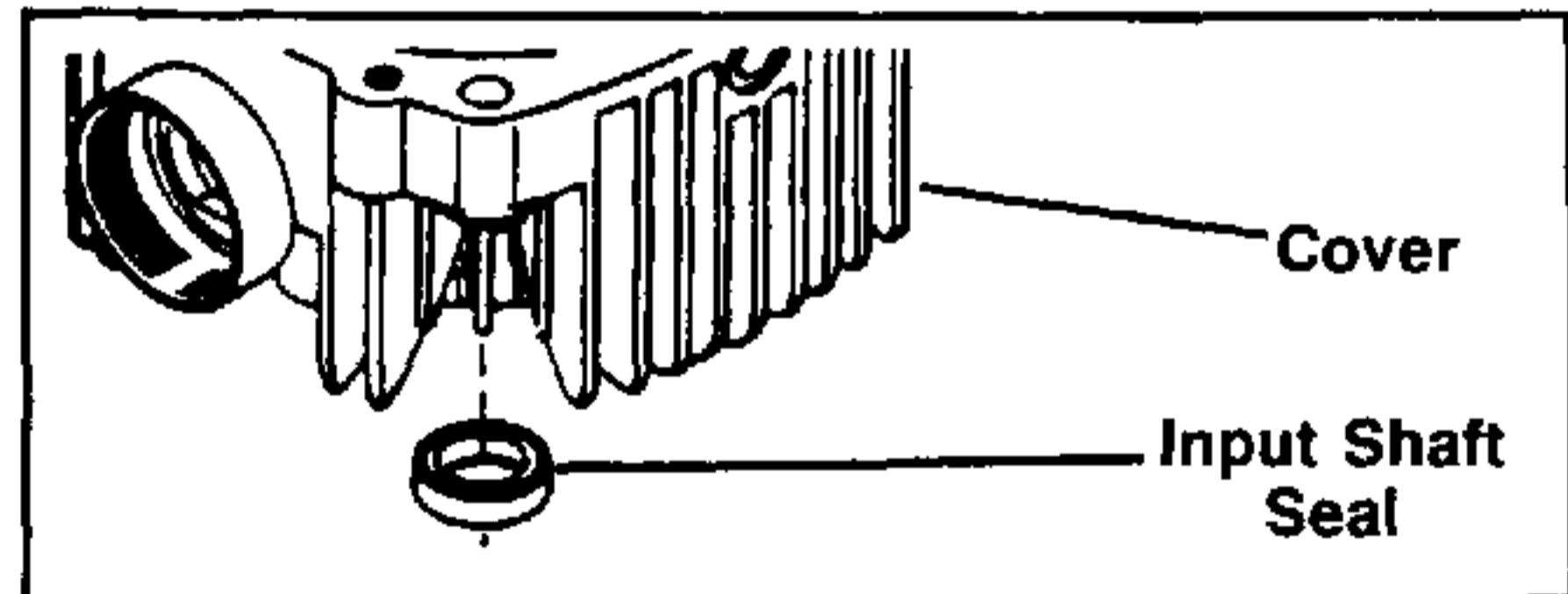

FIGURE 5.

8. Press or drive the input shaft seal from the cover.

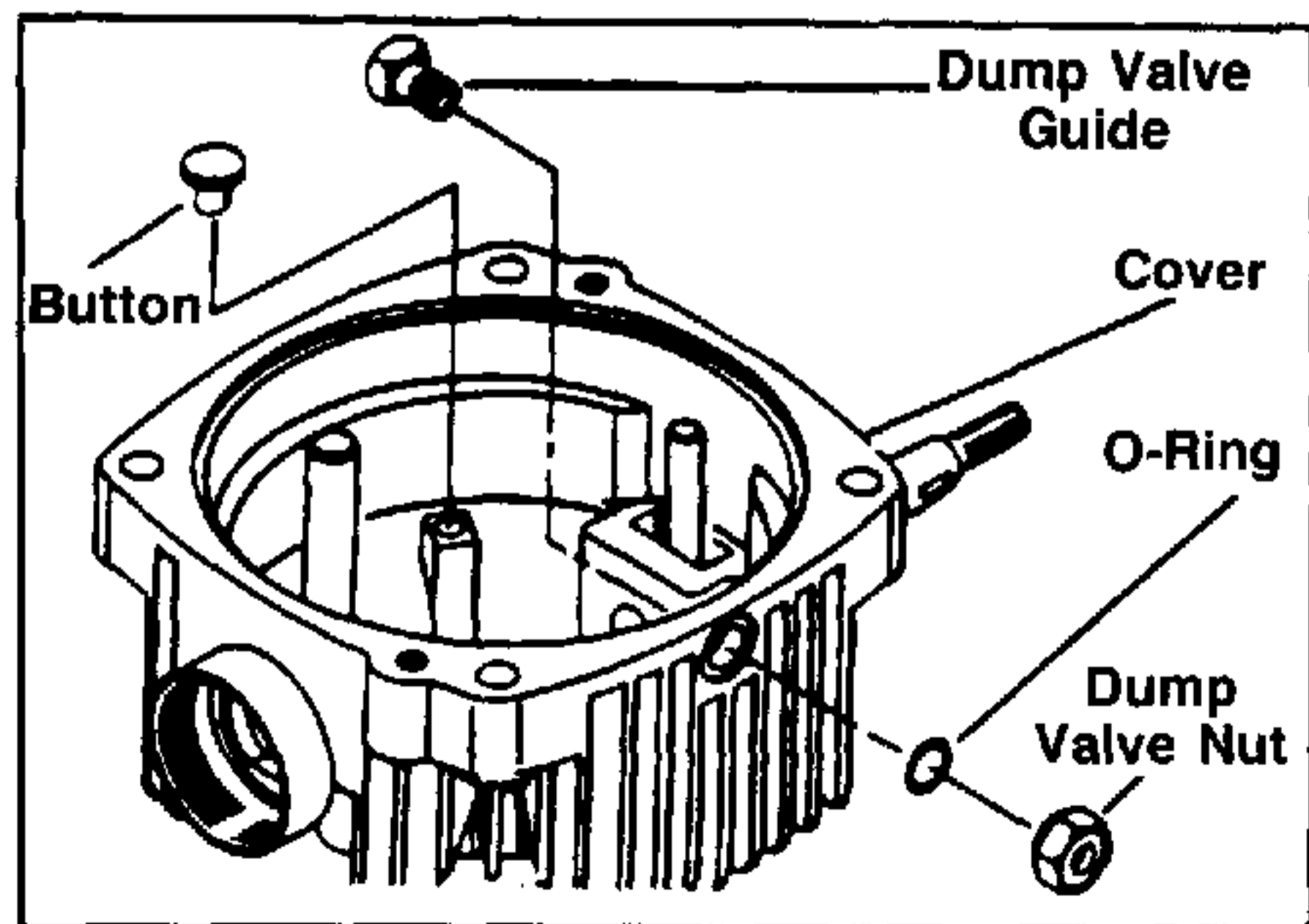

FIGURE 6.

9. Remove the bottom from the cover (Model 7 only). Where applicable, remove the dump valve guide, nut, and O-ring. Discard the O-ring.

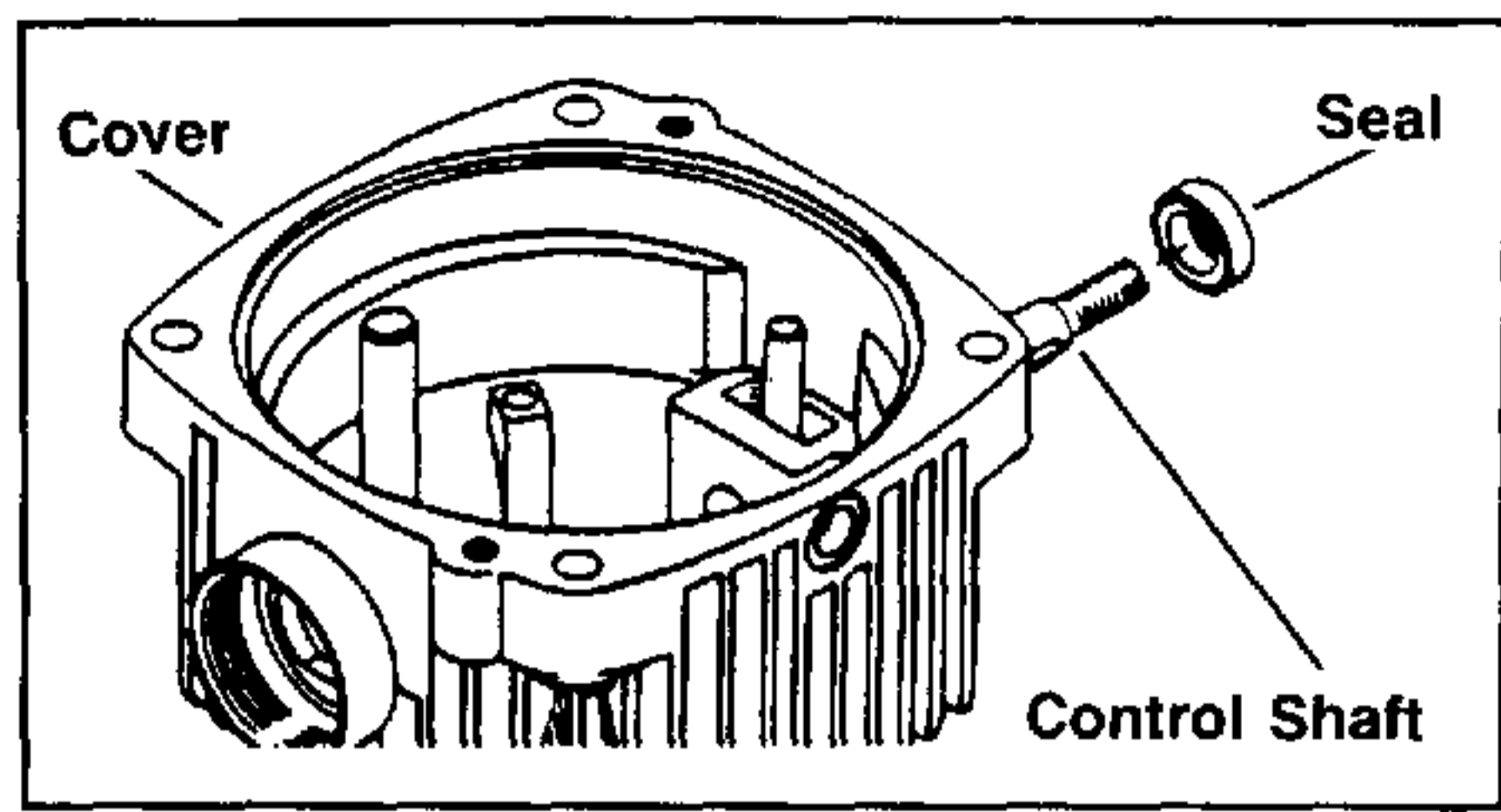

FIGURE 7.

10. Use a sharp, narrow tool to pierce the top metal part of the oil seal and remove seal from the cover.

Important: Do not scratch the control shaft or distort the seal counter bore when removing seal.

CAM RING—DISASSEMBLY/INSPECTION

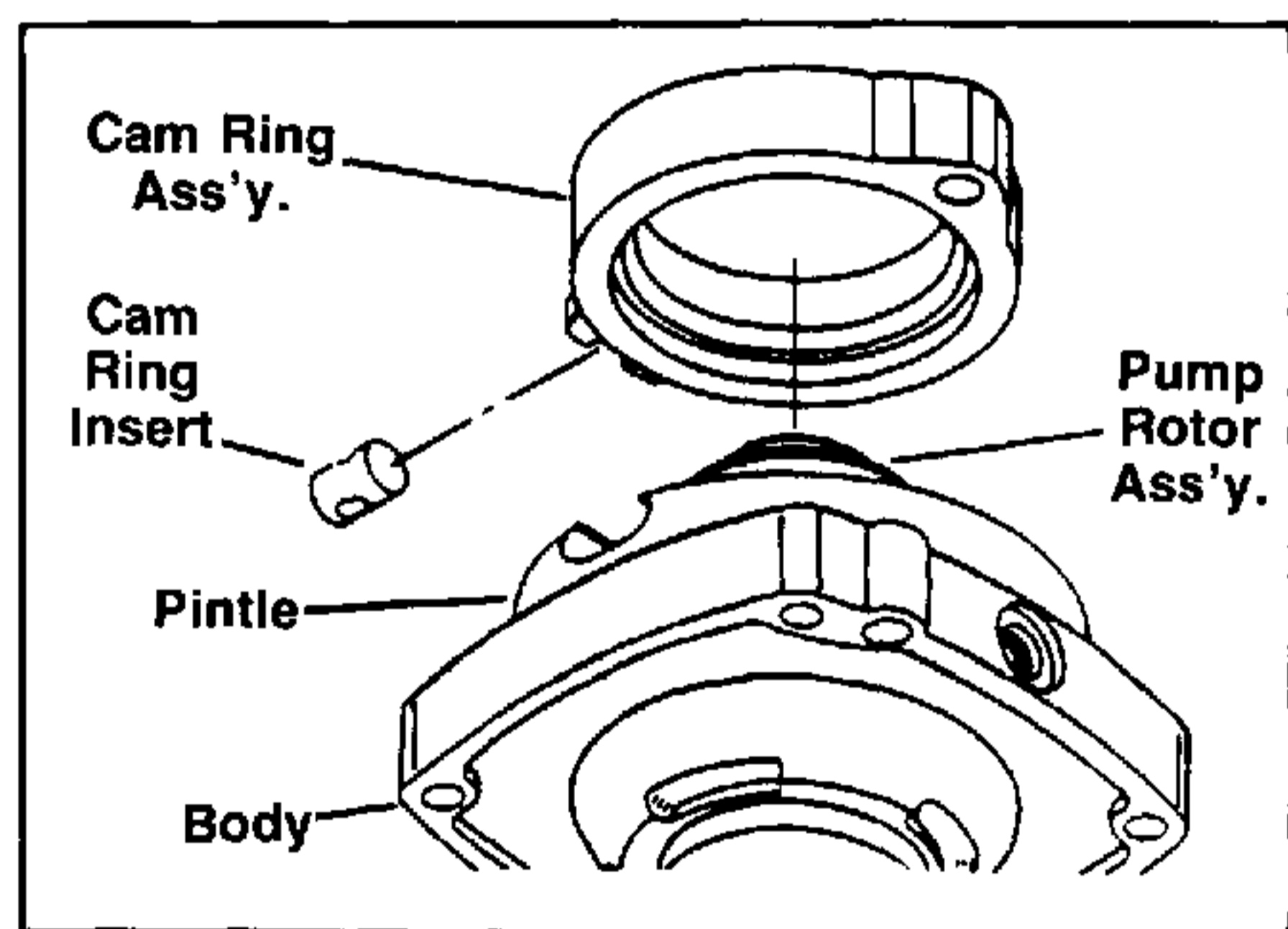

FIGURE 8.

11. Remove the cam ring assembly from the pintle. Remove the cam ring insert.

Important: Use special care when removing the cam ring from the pump rotor assembly. The ball pistons must remain in place as they are matched to the rotor bores. Use a wide rubber band to hold the ball pistons in place.

12. Inspect area where the ball pistons contact the pump race. This area must be smooth and completely free of irregularities. If it is not, replace the pump race.

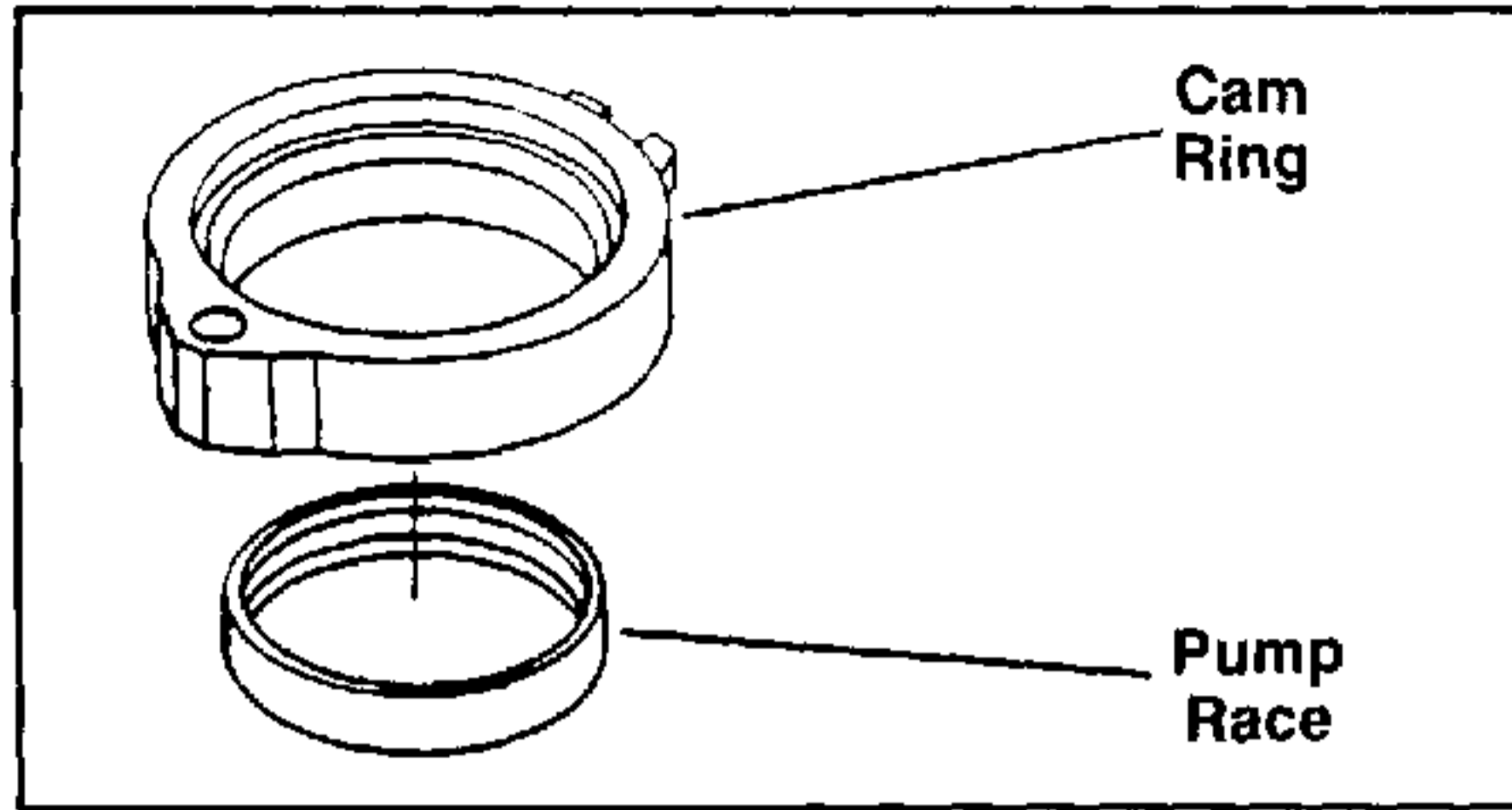

FIGURE 9.

Note: The pump race is press fit in the cam ring and will require a press to remove it. The cam ring and pump race are available as an assembly.

Note: If irregularities are noted in the pump race, it is reasonable to assume that one or more ball pistons and rotor bores will also be damaged.

PUMP ROTOR—REMOVAL

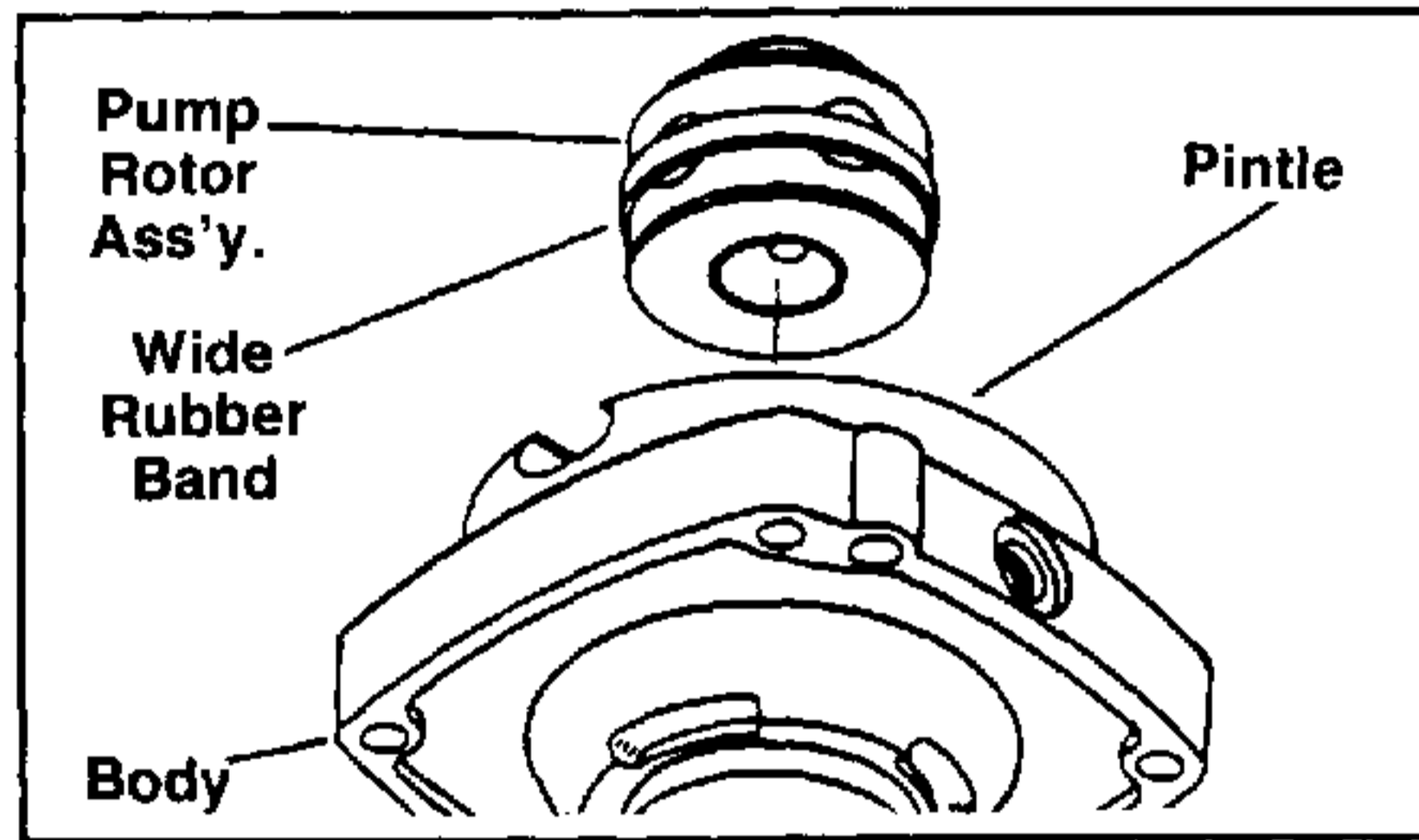

FIGURE 10.

13. Hold the pintle assembly in position against the body and remove the pump rotor assembly intact.

PINTLE ASSEMBLY—REMOVAL

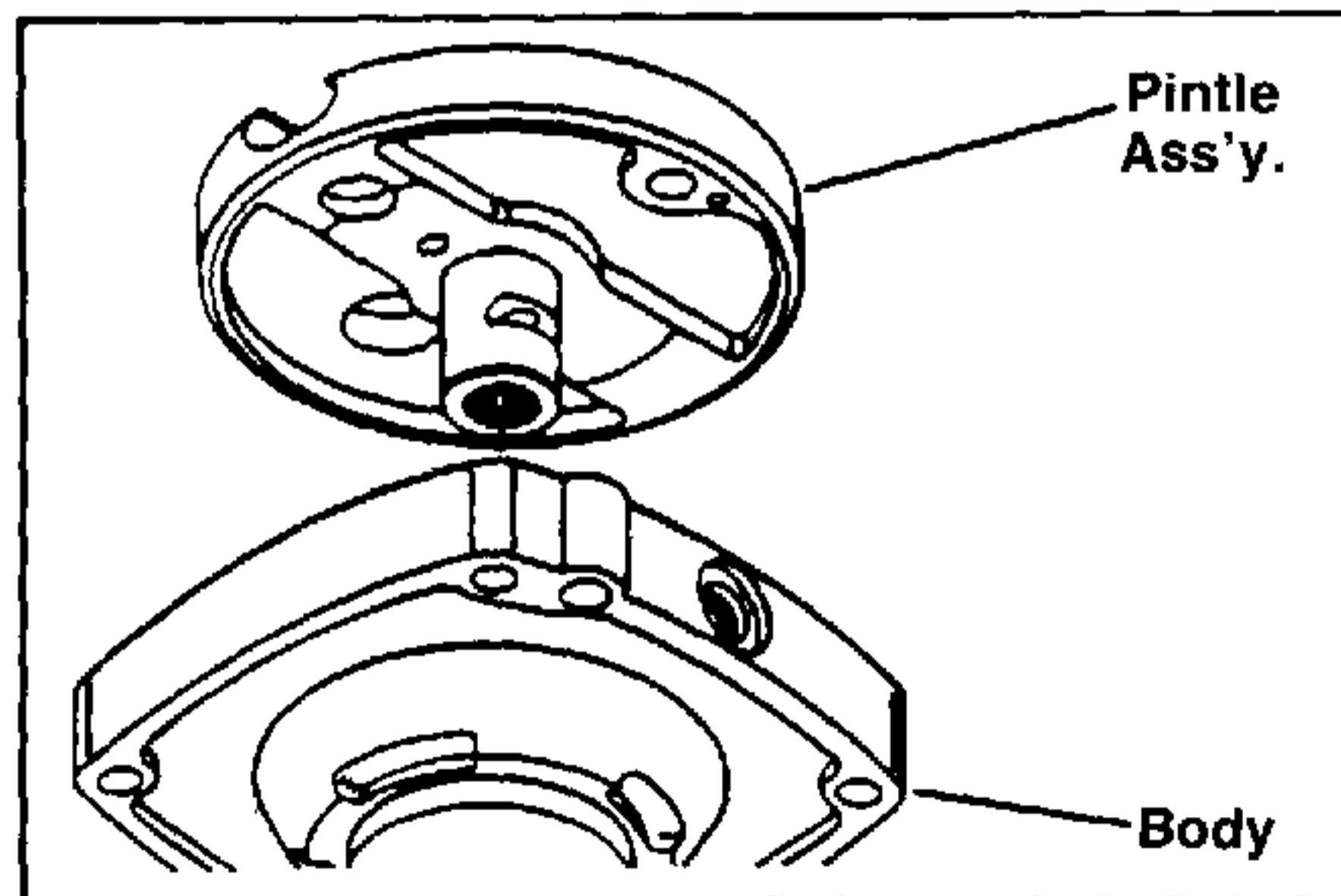

FIGURE 11.

14. Hold the motor rotor assembly in the bottom position and tap lightly on the body. Lift the pintle assembly out of the body.

PINTLE ASSEMBLY—DISASSEMBLY INSPECTION

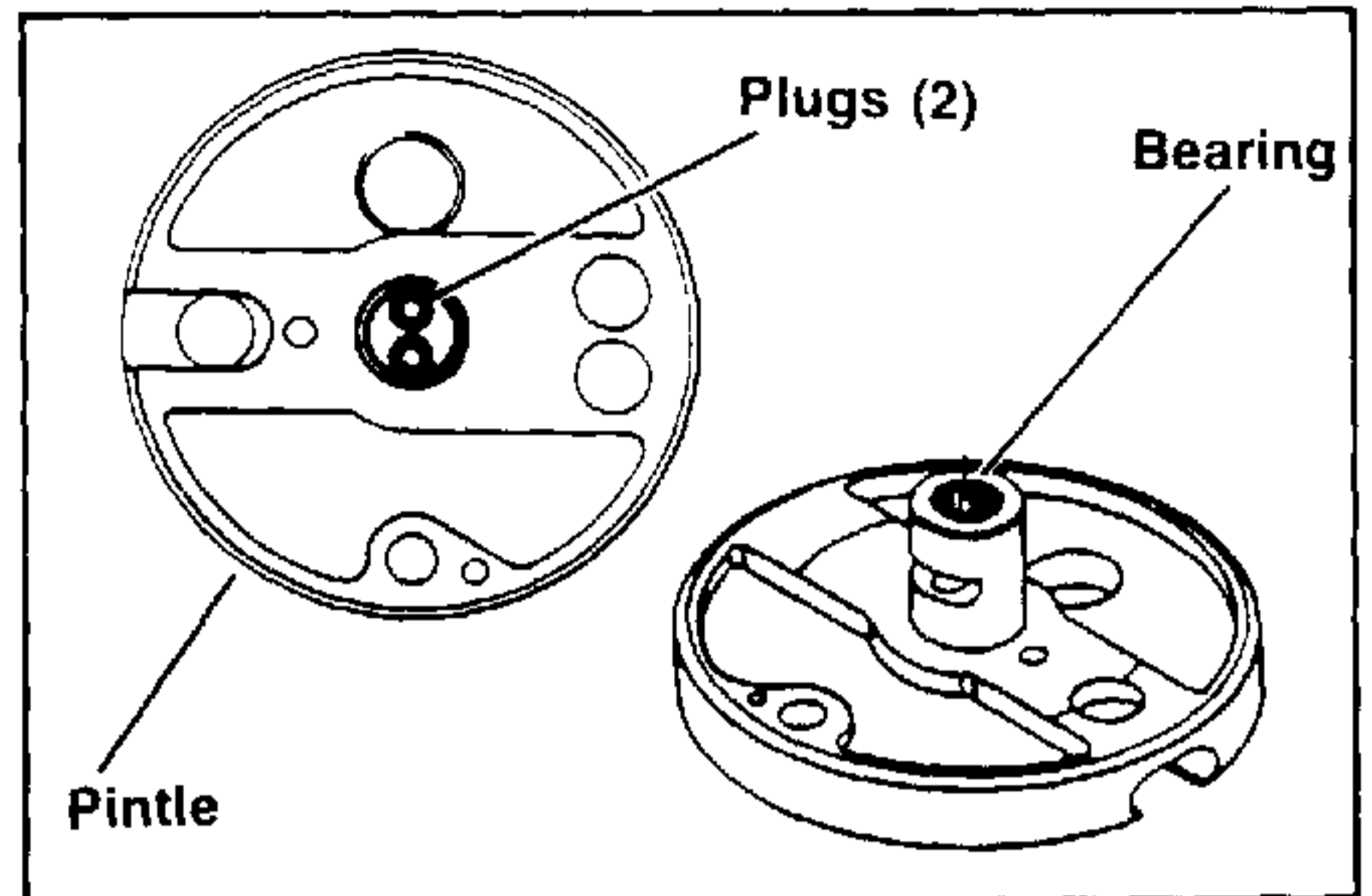

FIGURE 12.

15. We do not recommend complete disassembly of the pintle assembly for cleaning. Normal flushing should be all that is required. However, if complete disassembly is required, use the following procedures:

Note: Do not remove the two large plugs located on pintle journal.

16. Inspect the pintle journals, particularly in the porting area for any irregularities such as scoring or grooves cut between ports.

If any irregularities are noted: Replace the pintle assembly.

CHECK VALVE—REMOVAL

Note: Removal of check valves is not necessary if check valve balls move freely and seat properly.

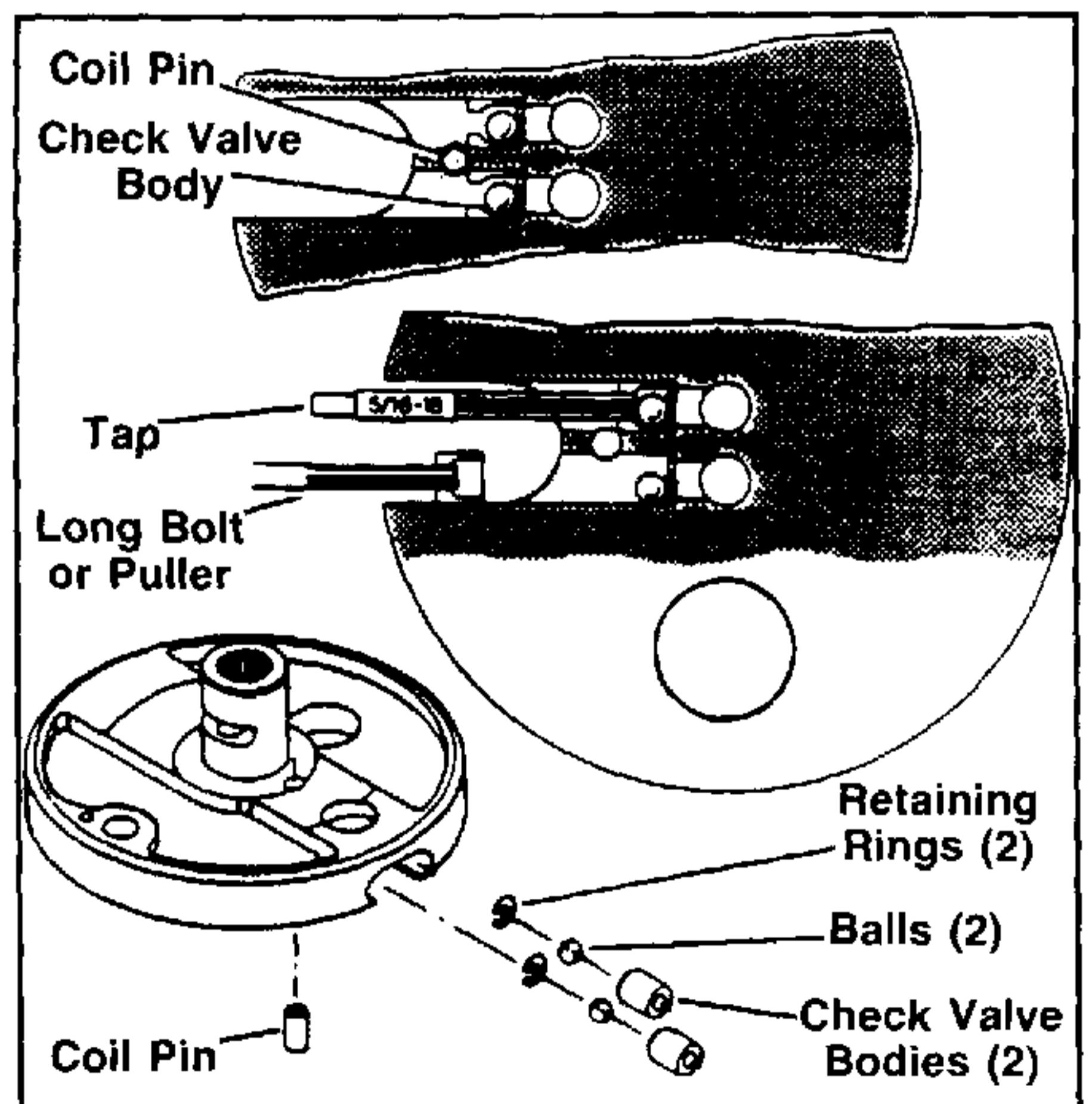

FIGURE 13.

17. Press or drive out the coil pin that retains the two check valve bodies. Use a four blade 5/16-18 tap to tap holes in check valve bodies. Insert a long bolt or a threaded puller, pull the check valve bodies from the pintle housing and discard them.
18. Remove check balls and retaining ring.
19. Inspect check valve balls and retaining rings. Replace any defective parts.

CHECK VALVE—INSTALLATION

20. Install retaining rings and check valve balls in bores of pintle. Press new check valve bodies in bores. Press far enough for coil pin clearance.

Important: To prevent dislodging of retaining rings do not drive check valve bodies into bores.

21. Press coil pin into pintle until flush with or slightly below surface.

DAMPENING PISTON—REMOVAL

(Model 7 Only)

Note: Remove only if surface is scored.

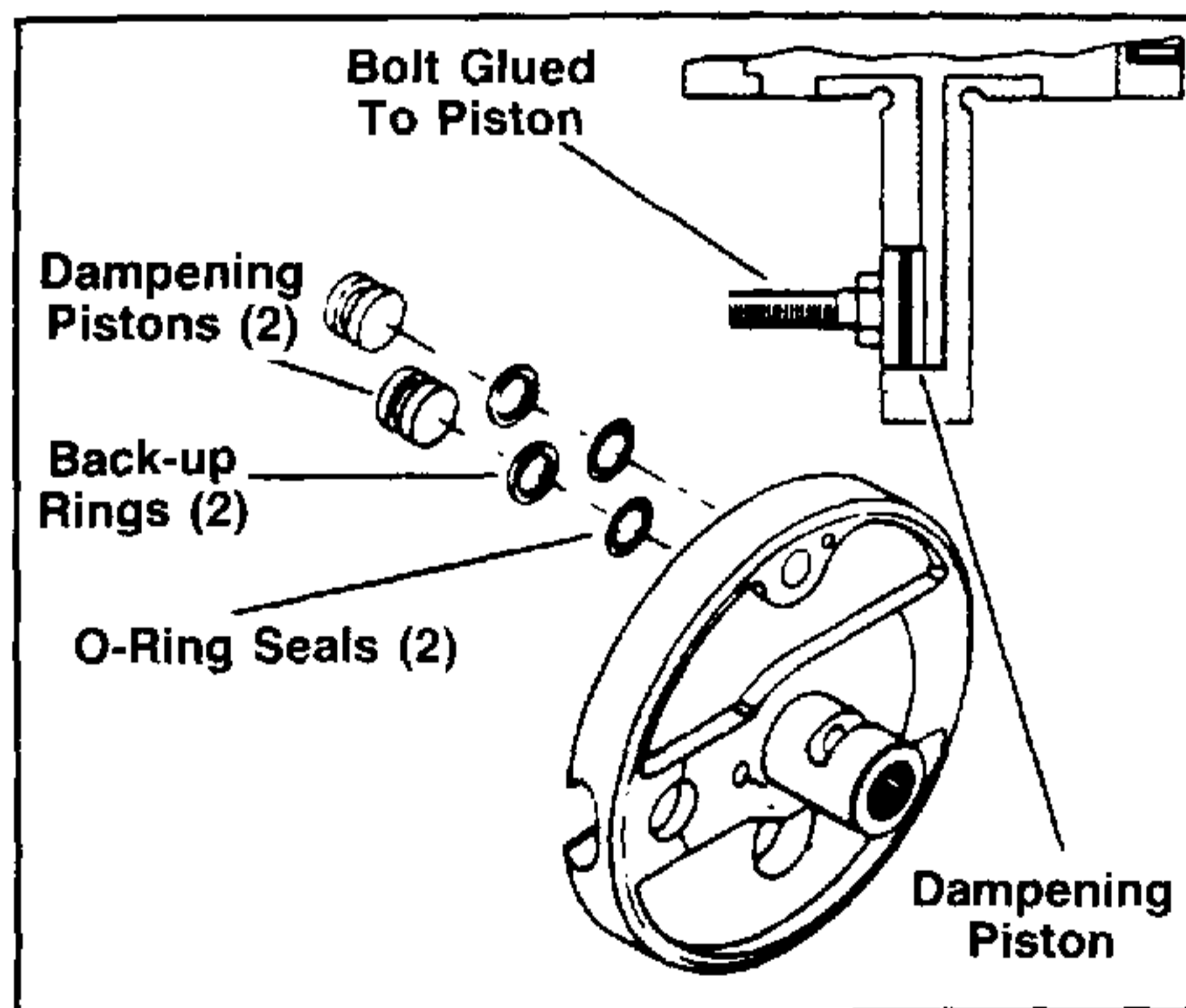

FIGURE 14.

22. To remove pistons, firmly tap the outside edge of pintle on a work surface. Remove back-up ring and O-ring from pistons.

Important: When dislodging dampening pistons, do not hit pintle journals or the pintle housing will be ruined.

Note: If tapping of pintle does not dislodge the pistons, use adhesive to cement a bolt or similar object to the pistons and pull them from the bore.

DAMPENING PISTON—INSTALLATION

23. Install new back-up rings nearest to the smooth piston face and O-rings in groove on a new piston.
24. Lubricate outer surface of the pistons. Press pistons (smooth face up) in bores in pintle to the bottom position.

MOTOR ROTOR—REMOVAL

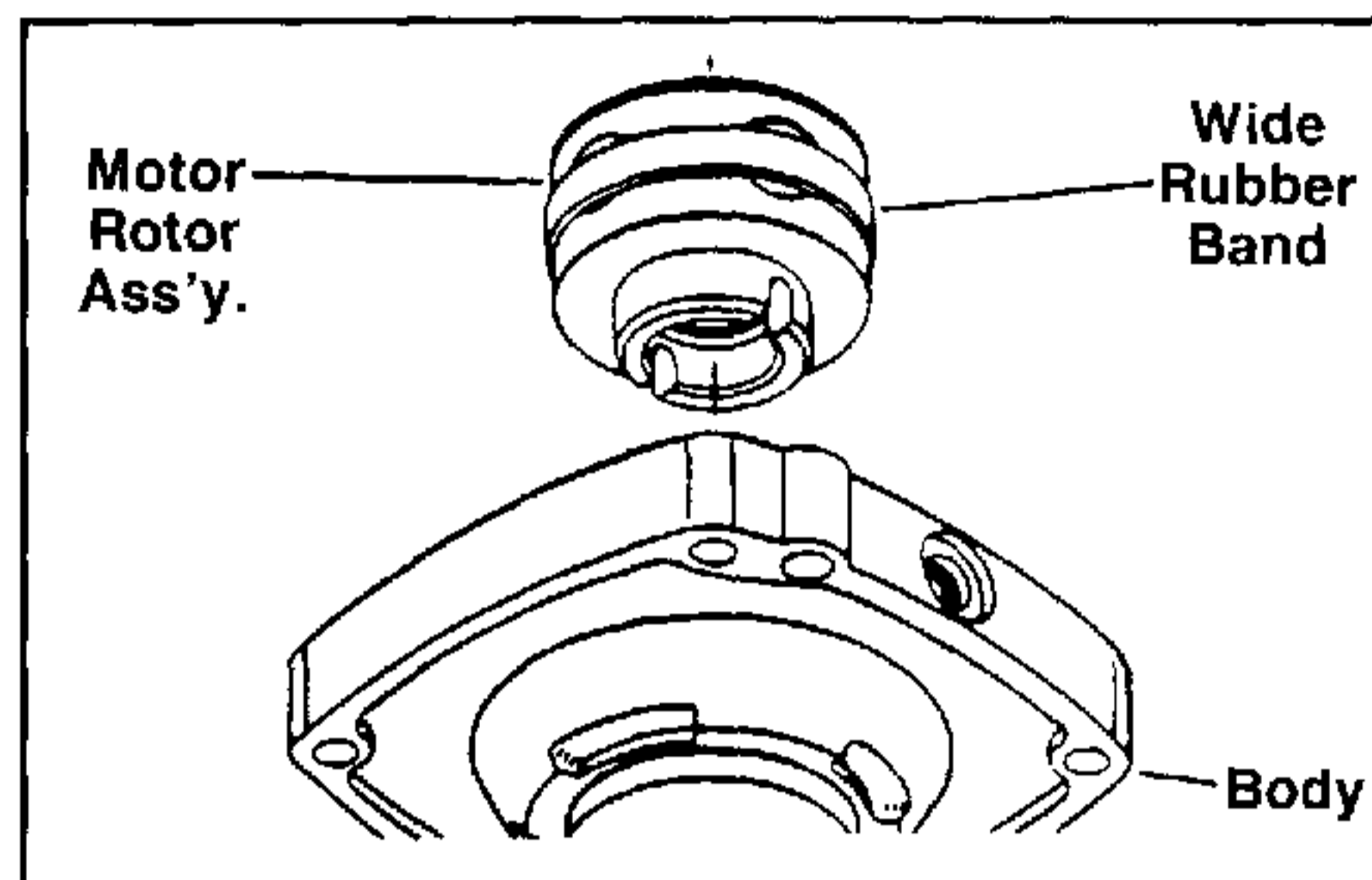

FIGURE 15.

25. Remove the motor assembly intact from the body.

Important: Use special care when removing the motor rotor from the body. The ball pistons MUST remain in place as they are matched to the motor bores. Use a wide rubber band to hold the ball pistons in place.

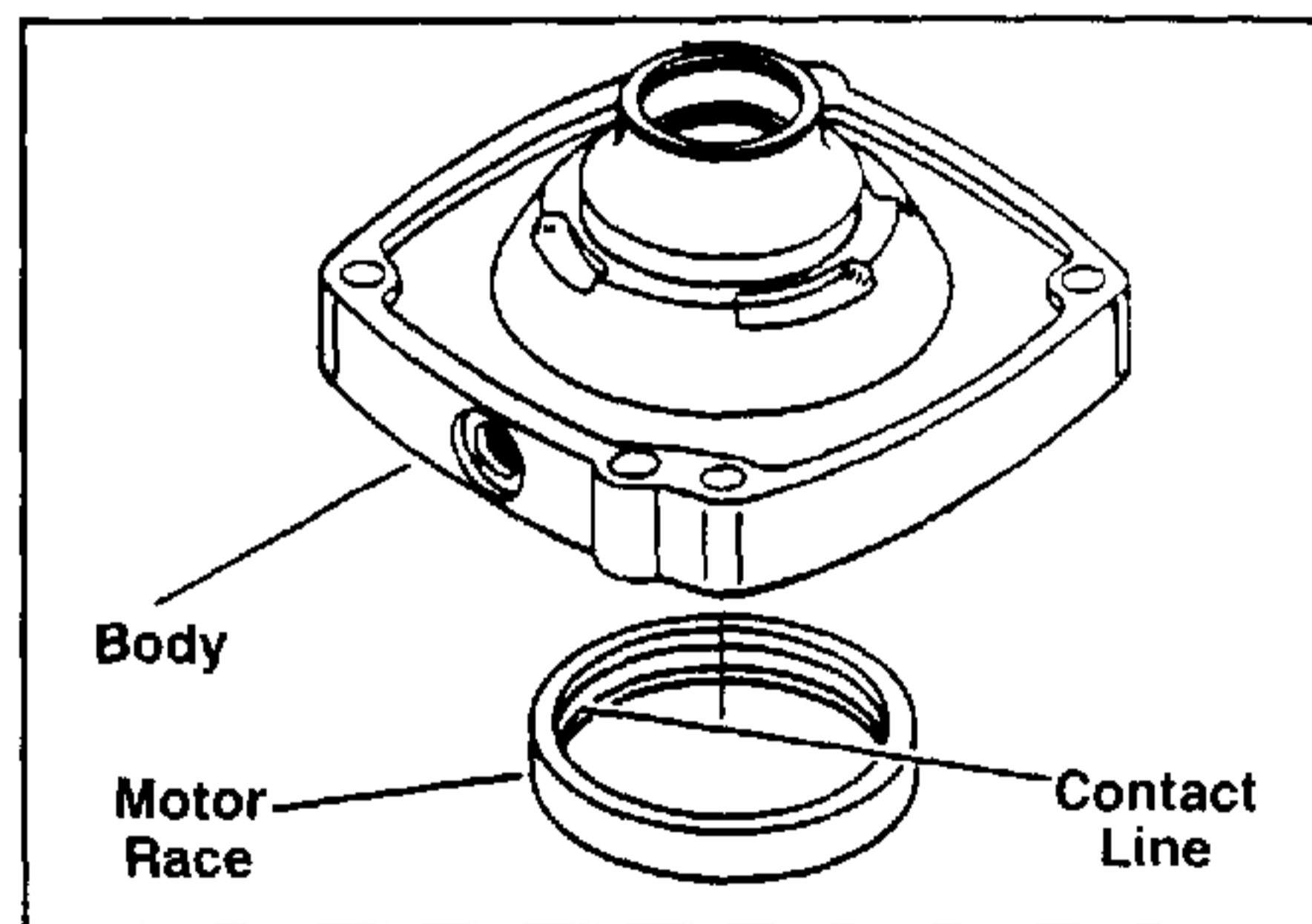

FIGURE 16.

26. Inspect the contact line of the motor ball pistons on the motor race located in body. This contact area must be smooth and completely free of any irregularities. If any irregularities are noted, replace the motor race.

Note: If irregularities are noted in the motor race, it is reasonable to assume that one or more ball pistons and rotor bores will also be damaged.

ROTOR ASSEMBLIES—DISASSEMBLY INSPECTION

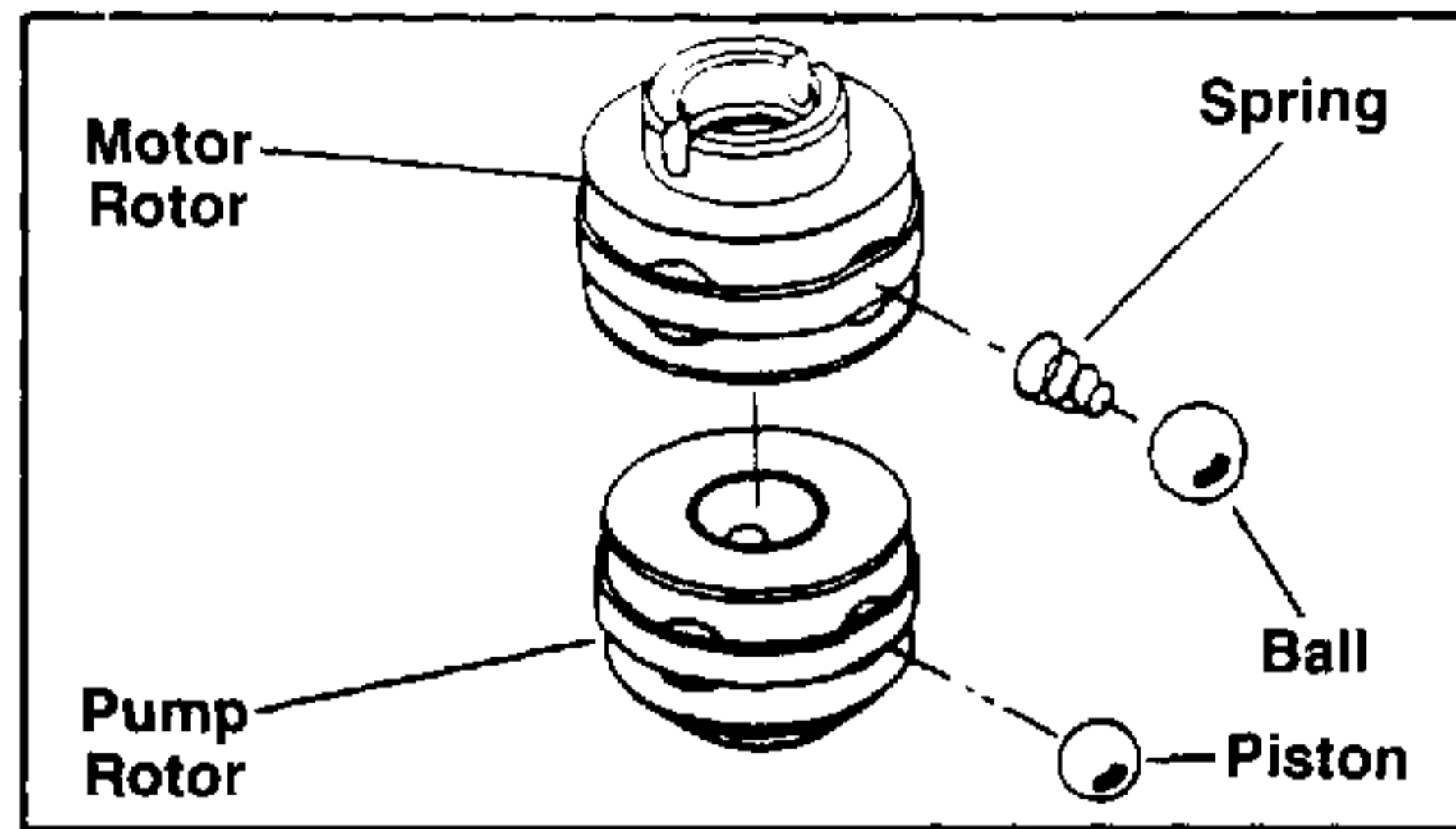

FIGURE 17.

27. Inspect the rotor assemblies. Remove the piston balls from the rotor, one at a time, by working clockwise from the letter stamped in the face of the rotor and placing in a prepared container.

Note: Each ball must be replaced in the same bore from which it was removed. Use a suitable container for piston ball storage such as an egg carton or ice cube tray.

28. Inspect for broken or collapsed springs in the motor rotor assembly.

Note: When broken or collapsed springs are found with no other irregularities, the springs may be replaced individually without replacing the complete motor rotor assembly.

29. Inspect the piston balls. They must be smooth and completely free of any irregularities.

30. Inspect the rotor bores, rotor bushing and pintle journals for irregularities or excessive clearance. The ball piston to rotor bore clearance is select fit electronically to .0002 to .0006 of an inch. When irregularities or excessive clearance are noted, replace the complete rotor assembly.

BODY—DISASSEMBLY

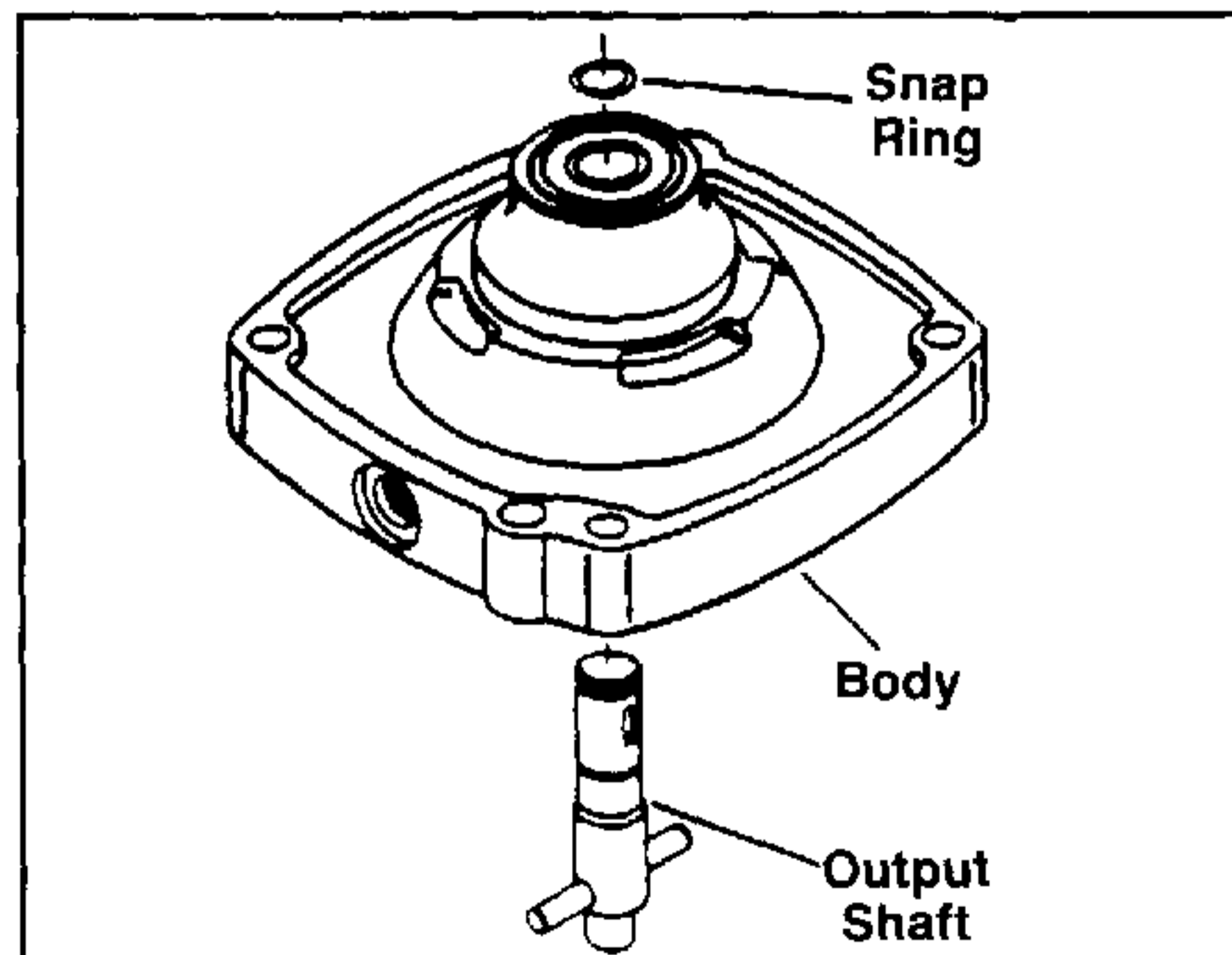

FIGURE 18.

Install ball pistons in their matching bores. Hold them in place with a rubber band.

31. Remove the snap ring that retains the output shaft and tap or press the shaft from the body.

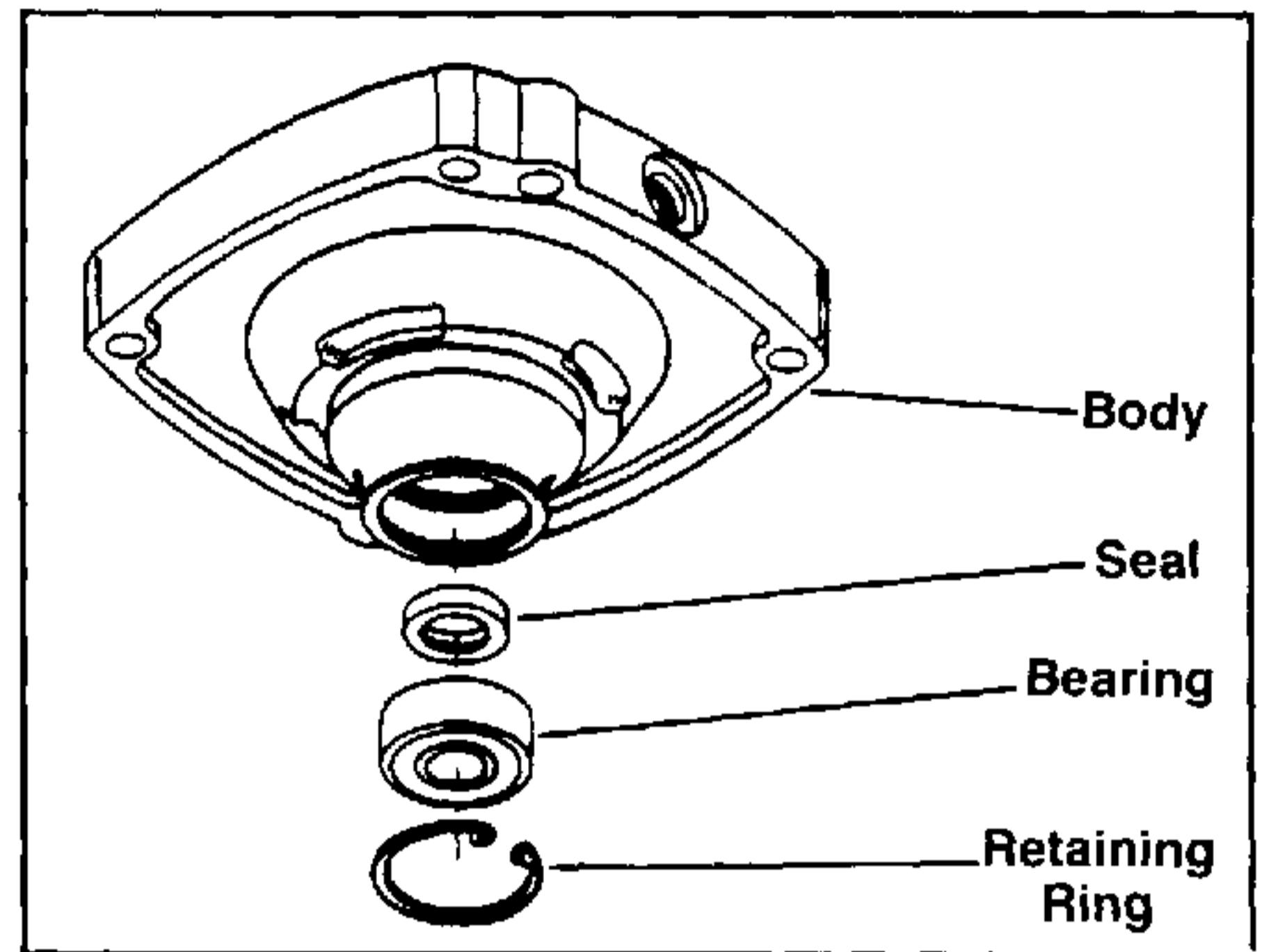

FIGURE 19.

32. Remove the large retaining ring that retains the output bearing to body. Drive or press the output bearing and seal from the motor body.

COVER—REASSEMBLY

33. Inspect cover assembly, especially around the control shaft area. Replace the cover assembly if it is broken, cracked or if side clearance between control shaft and cover exceeds .006".

34. In most cases, it will not be necessary to remove the control shaft from the cover. If the dowel is loose or broken in the control shaft, remove the shaft using the following procedures.

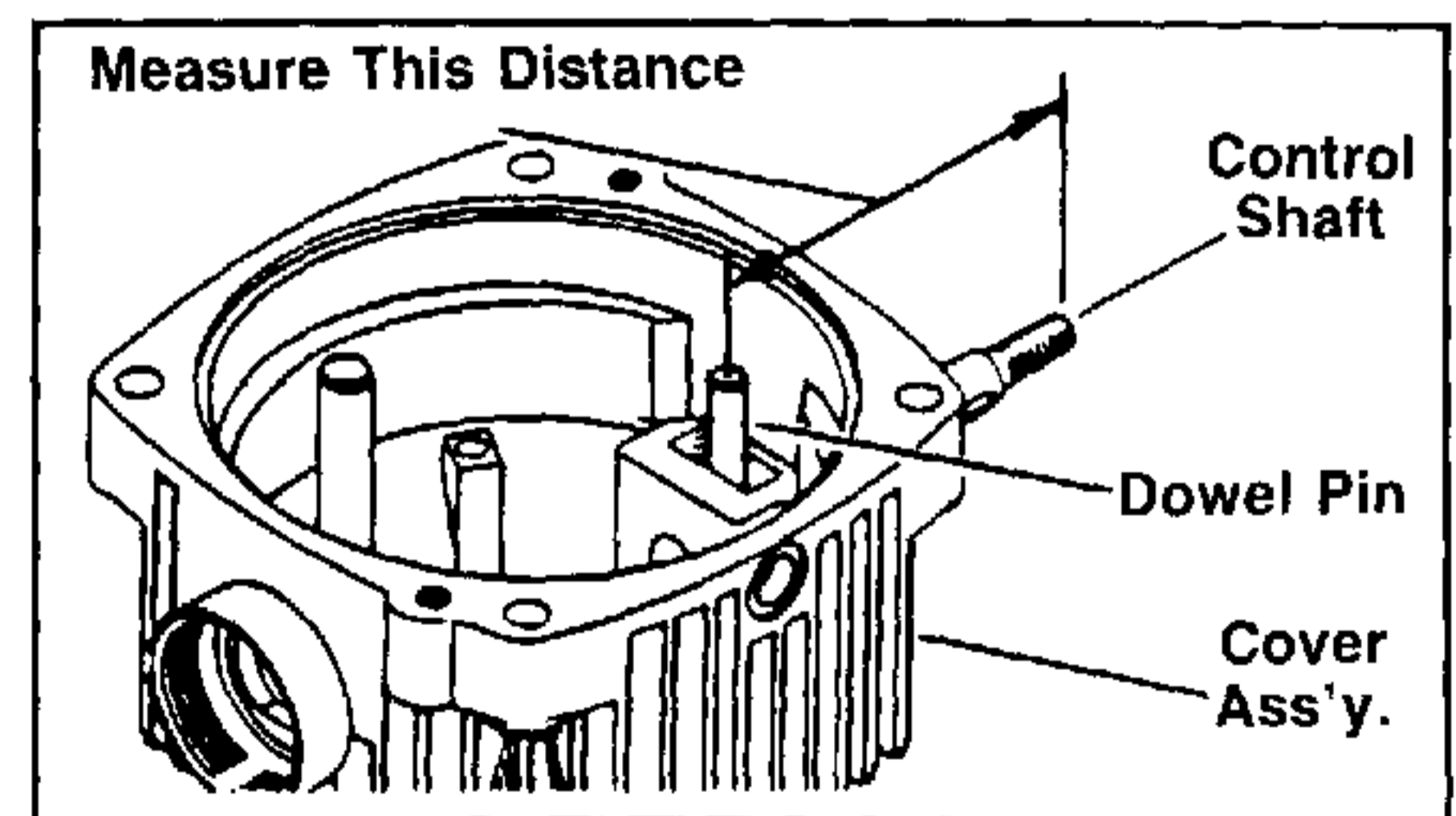

FIGURE 20.

35. Measure the distance between center of dowel pin and the end of the shaft as shown in figure 20.

36. Turn cover over. Use this dimension to locate dowel pin in cover face. Drill 11/32" diameter hole at center point of dowel pin. Drill hole exactly in line with center of shaft.

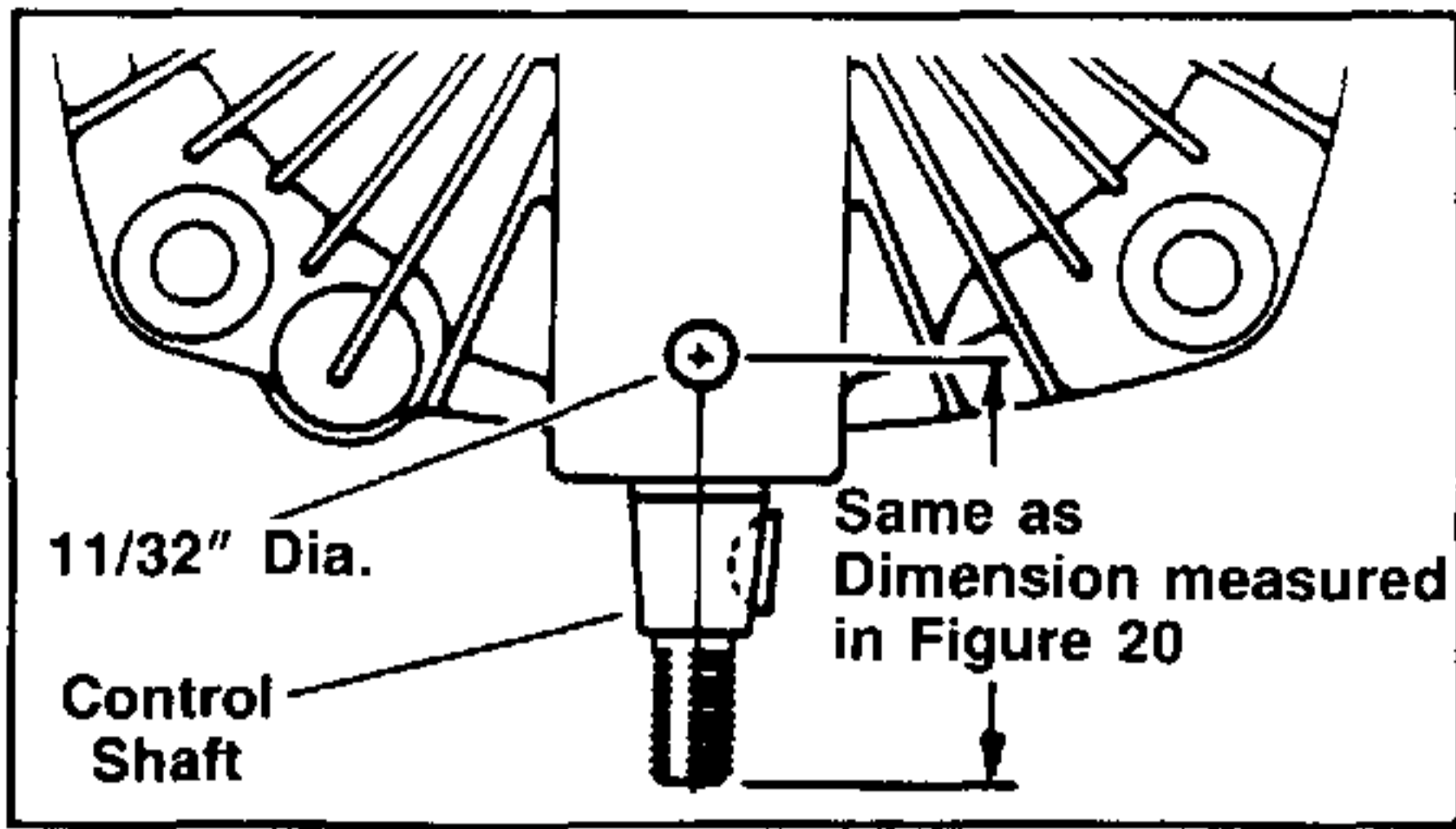

FIGURE 21.

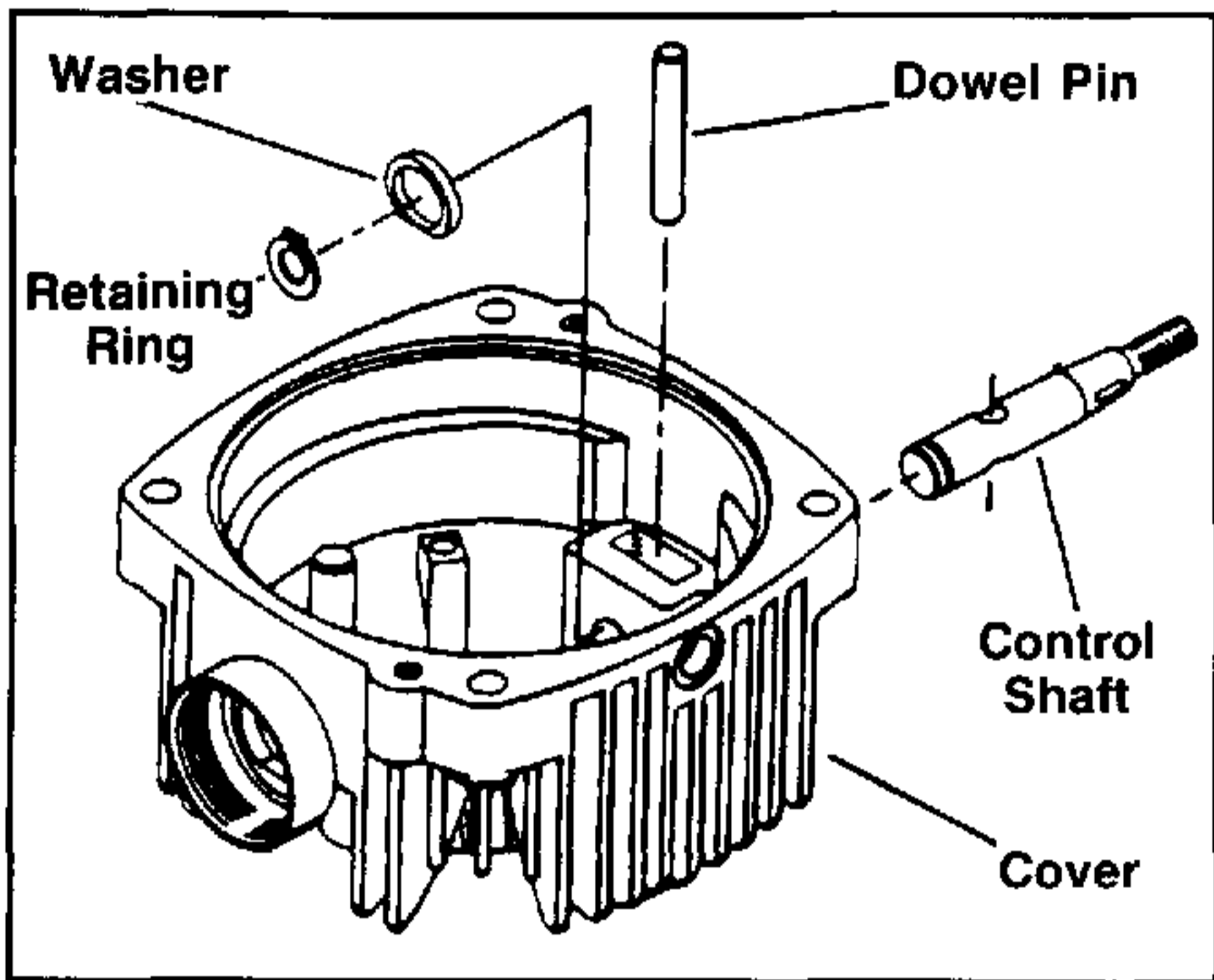

FIGURE 22.

37. Press loose or broken dowel pin out. Remove retaining ring and washer from end of control shaft. Remove control shaft outward from the cover.

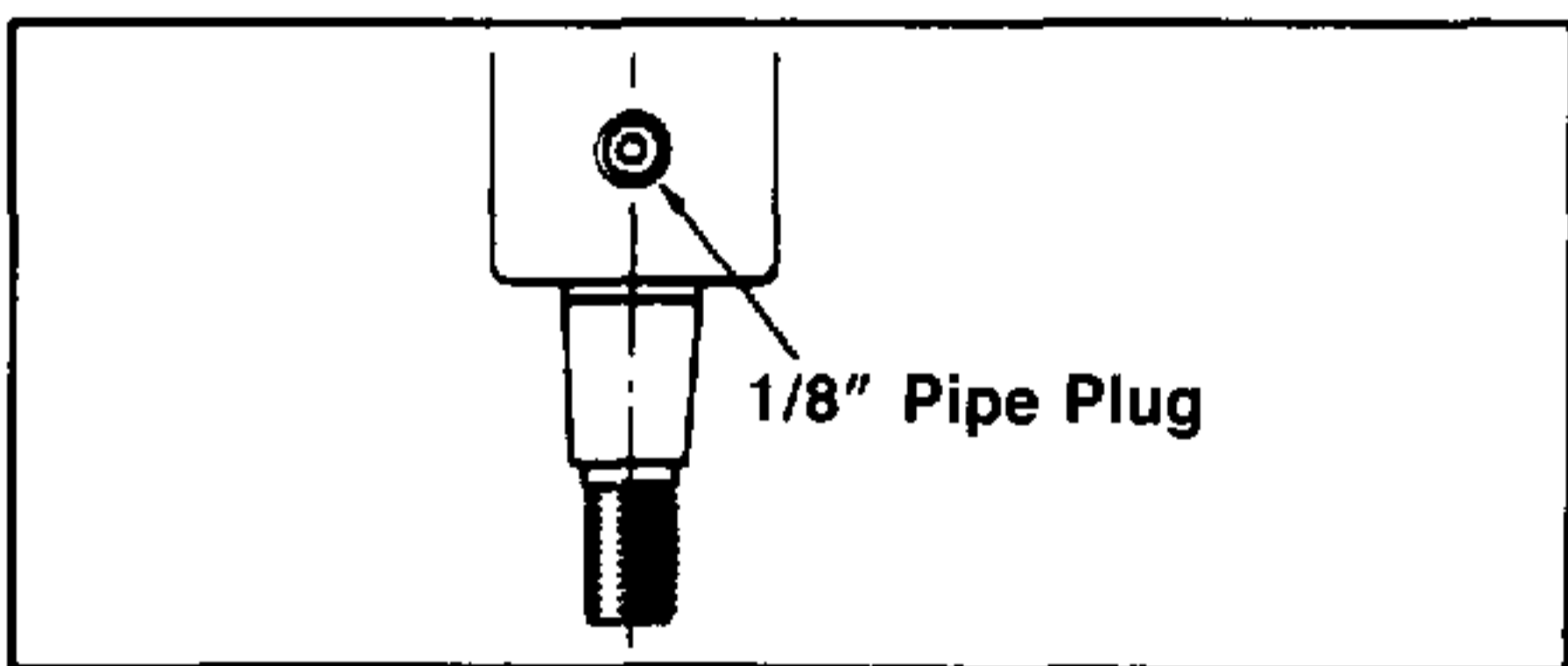

FIGURE 23.

38. Tap hole drilled with 1/8" pipe tap. Install 1/8" flush type pipe plug.

39. Lubricate a new control shaft and install in cover. Replace washer and retaining ring on end of control shaft. Press new dowel pin through shaft leaving 1-1/8 inch of dowel extending from shaft.

Important: When pressing the new dowel pin into the control shaft, the Woodruff key in control shaft must be to the left looking at the threaded end of shaft.

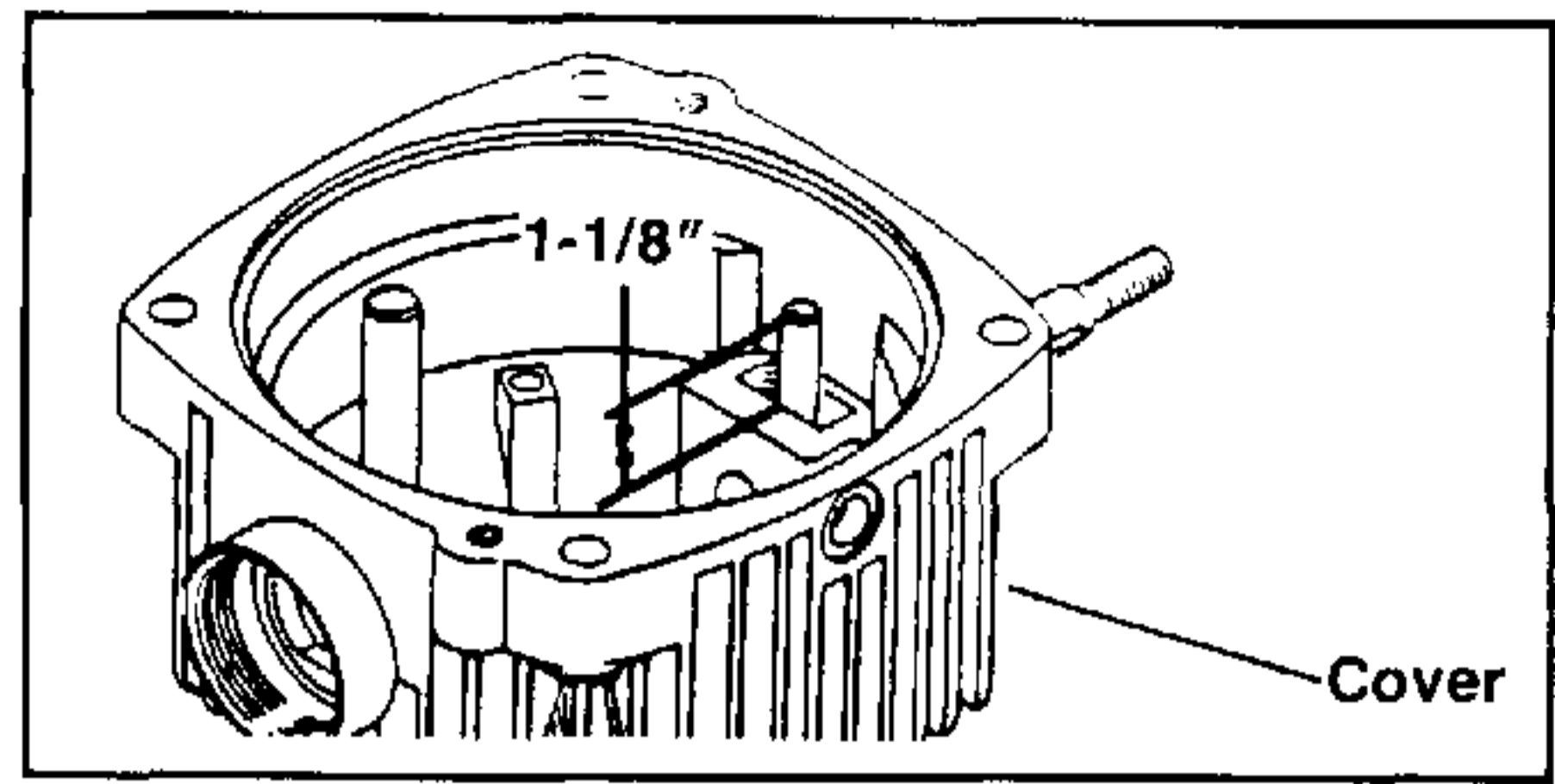

FIGURE 24.

40. Lubricate I.D. of new oil seal with clean lubricant. Then press or tap seal in bore until completely seated.

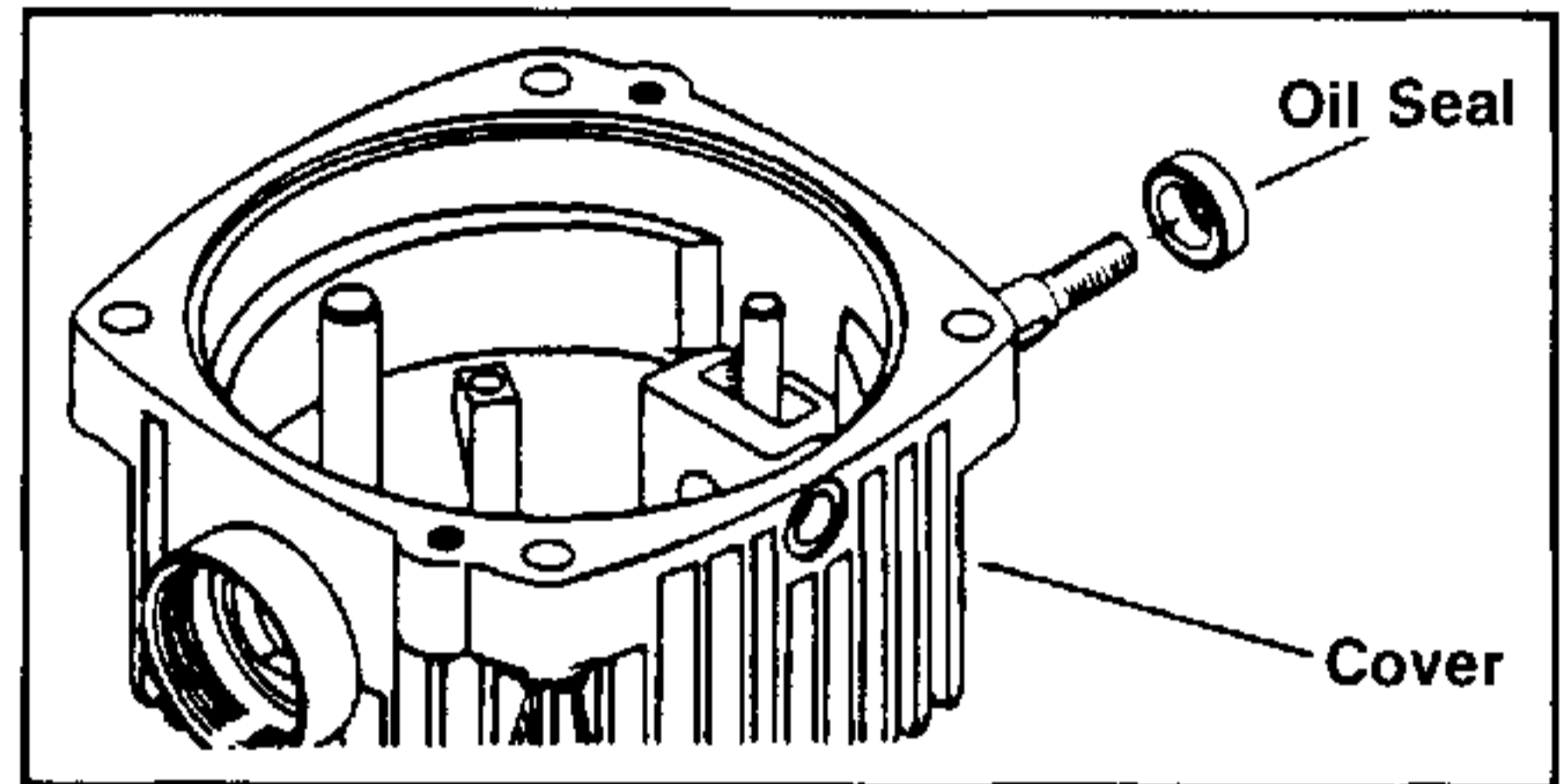

FIGURE 25.

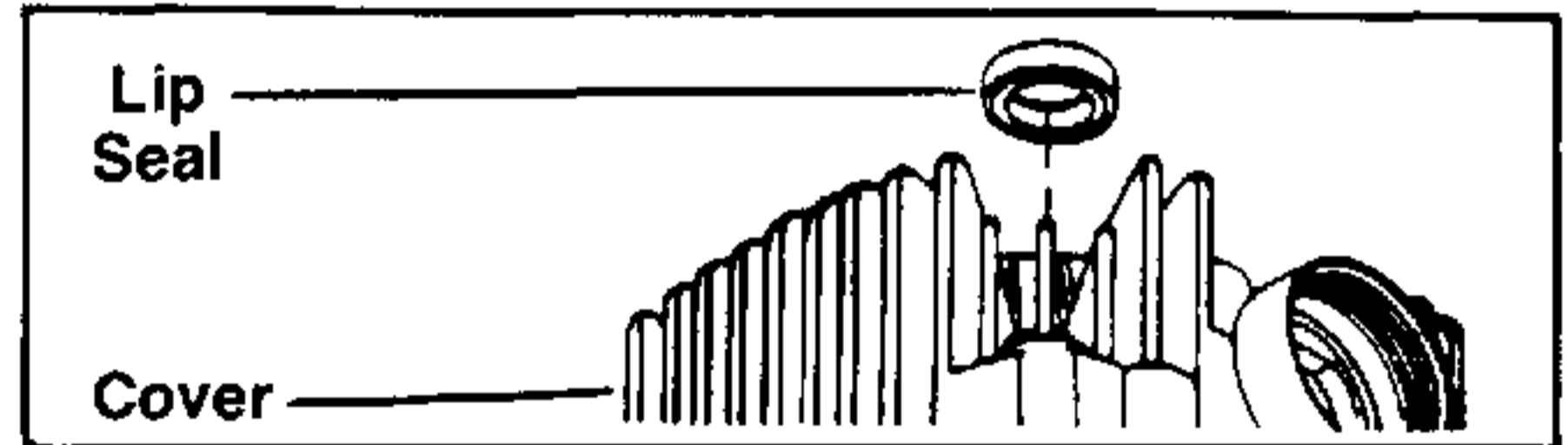

FIGURE 26.

41. Lubricate inner surface of the lip seal with a clean lubricant. Press or tap seal into the bottom position in cover counter bore.

Important: Be careful not to damage the inner portion of the oil seal. Excessive pressing or driving of the oil seal will damage the rubber portion of the seal.

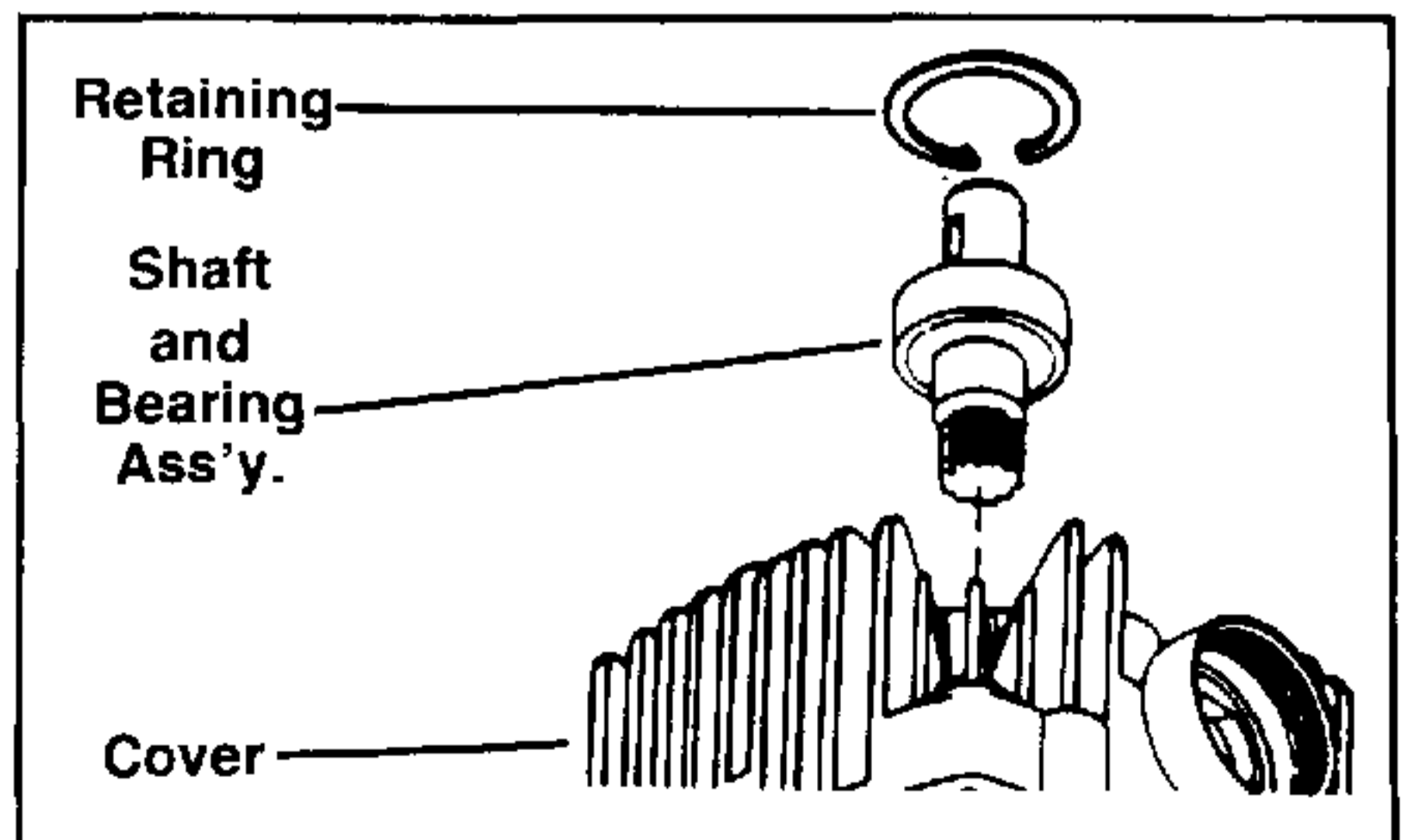

FIGURE 27.

42. Install the input shaft assembly into bottom position in the counter bore in cover. Install the retaining ring in the groove located in front cover.

CAM RING—INSTALLATION

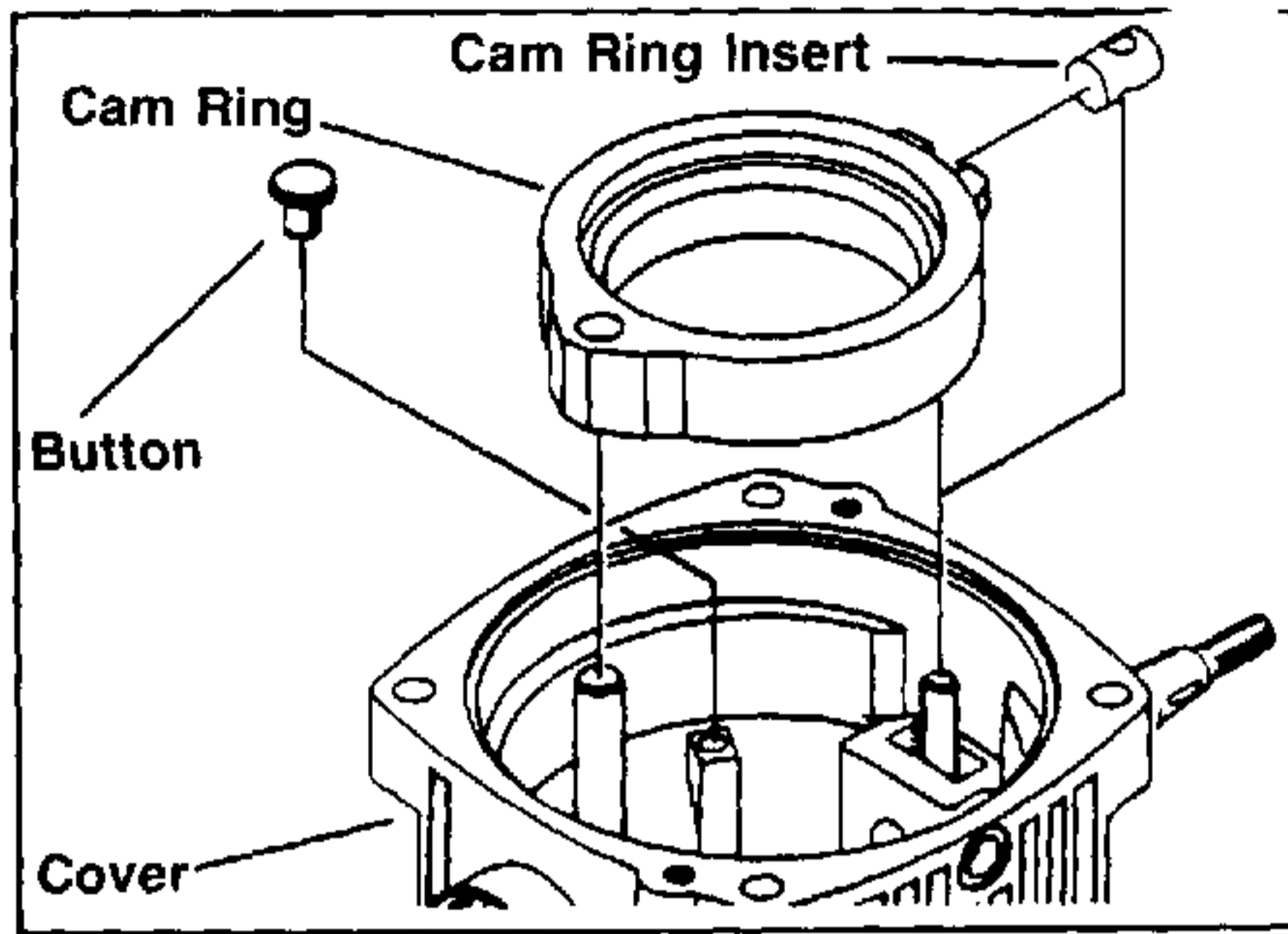

FIGURE 28.

43. Install the button in the hole located in the cover (in Model 7 only).
44. Install the cam ring insert with the hole away from the cam ring as shown in figure 28.
45. Align the cam ring with the control shaft pin and the cam ring pivot pin.

Install the cam ring with the flush side of the bearing race facing the cover. Press in firmly until the cam ring has bottomed in the cover assembly.

Important: Cam ring must move freely from stop to stop. If binding occurs at either stop rotate the cam ring insert 180°. Check the cam ring movement again.

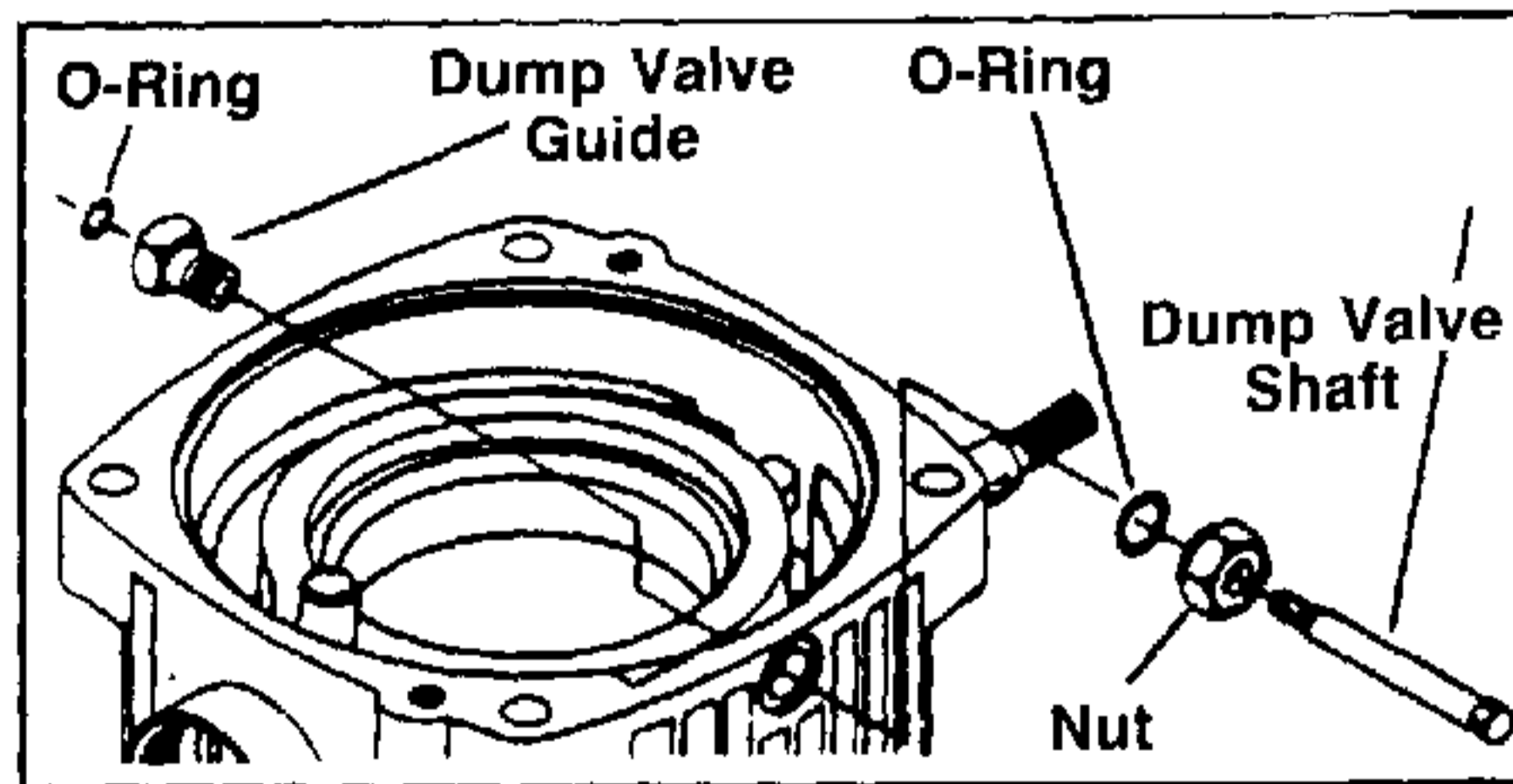

FIGURE 29.

46. Where applicable, lubricate O-ring and install in groove located in dump valve guide. Install guide through cover and install O-ring and nut. Lubricate dump valve, valve shaft and install in guide assembly.

Note: Check dump valve shaft for freedom of movement.

PUMP ROTOR—INSTALLATION

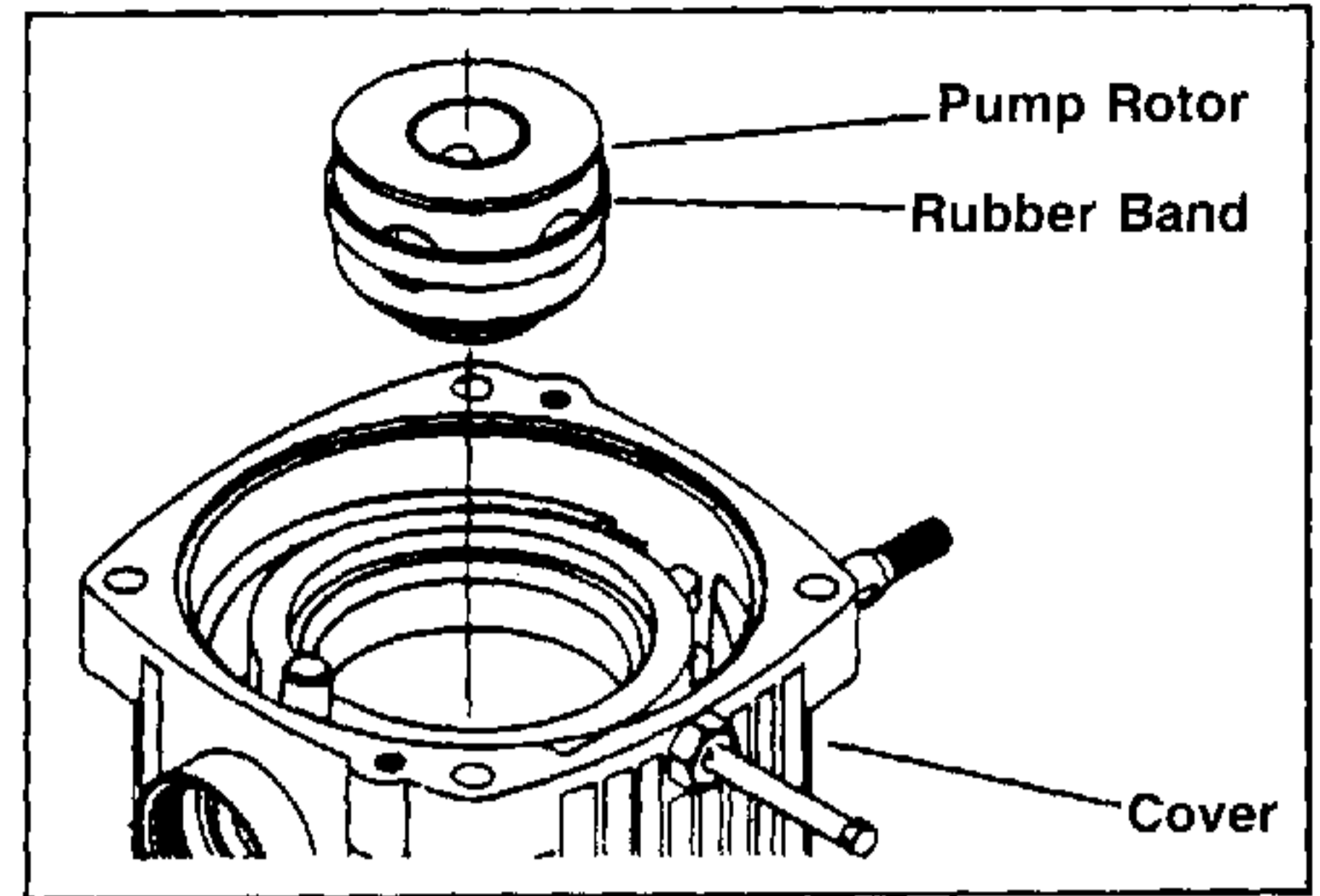

FIGURE 30.

47. Align the internal spline in the pump rotor assembly with the external spline on the input shaft and install the pump rotor in the cover.

Remove the rubber band retaining the ball pistons (if used).

PINTLE—INSTALLATION

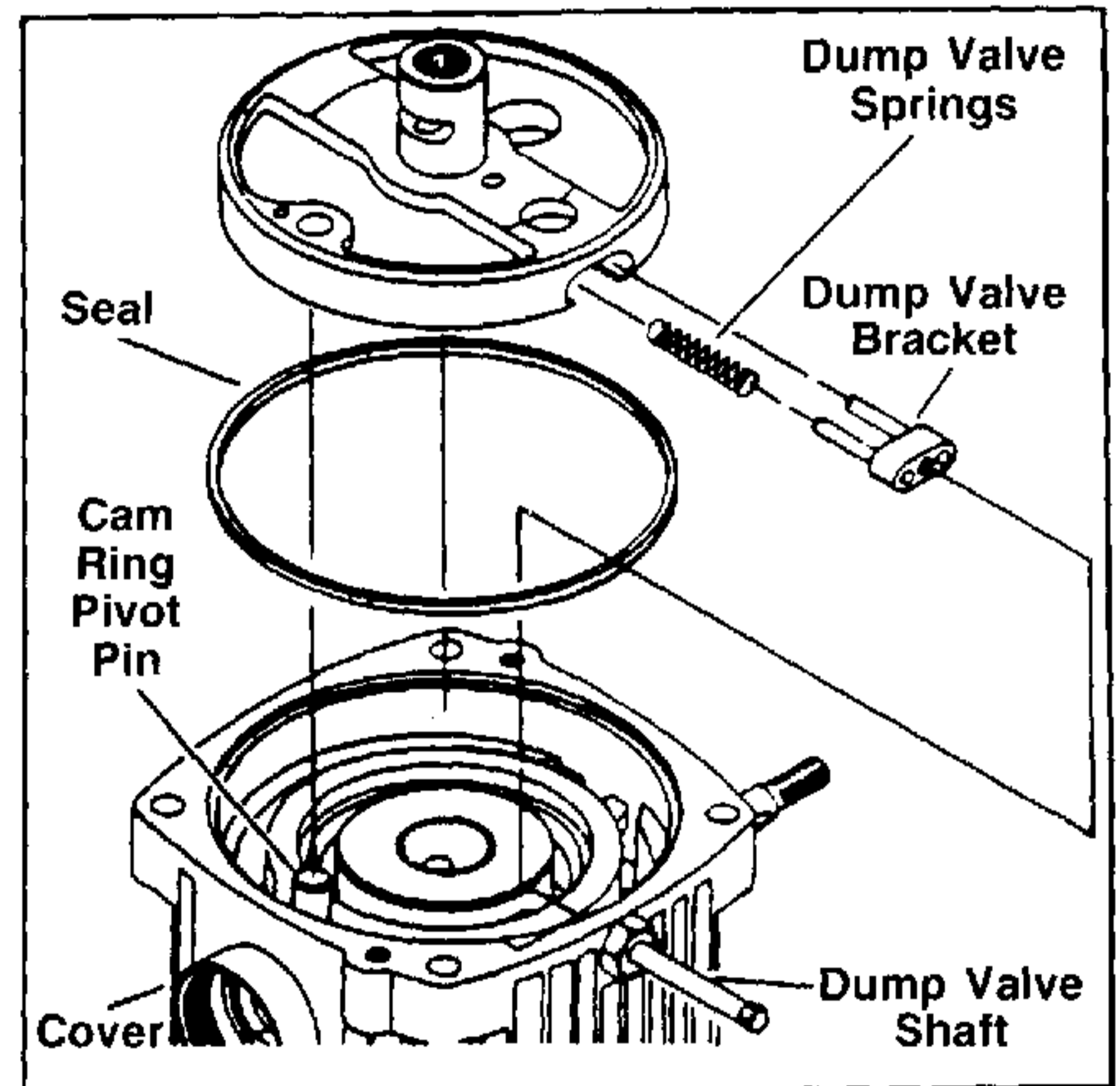

FIGURE 31.

48. Install the two springs and dump valve bracket into pintle assembly.

Use a small screwdriver to compress and hold dump valve bracket into pintle to clear previously installed dump valve guide located in cover.

49. Align pintle assembly with the cam ring pivot pin and guide pintle assembly into pump rotor. Push to bottom position in cover.

Note: Do not force pintle through the pump rotor assembly as it is a slip fit. The pump rotor assembly must turn freely on the pintle by hand. If not, recheck pintle installation.

50. Push dump valve shaft in and thread into dump valve bracket. **Torque to 2-3 Foot Pounds.**

51. Lightly grease new cover sealing ring and install in the groove in the cover.

BODY—REASSEMBLY

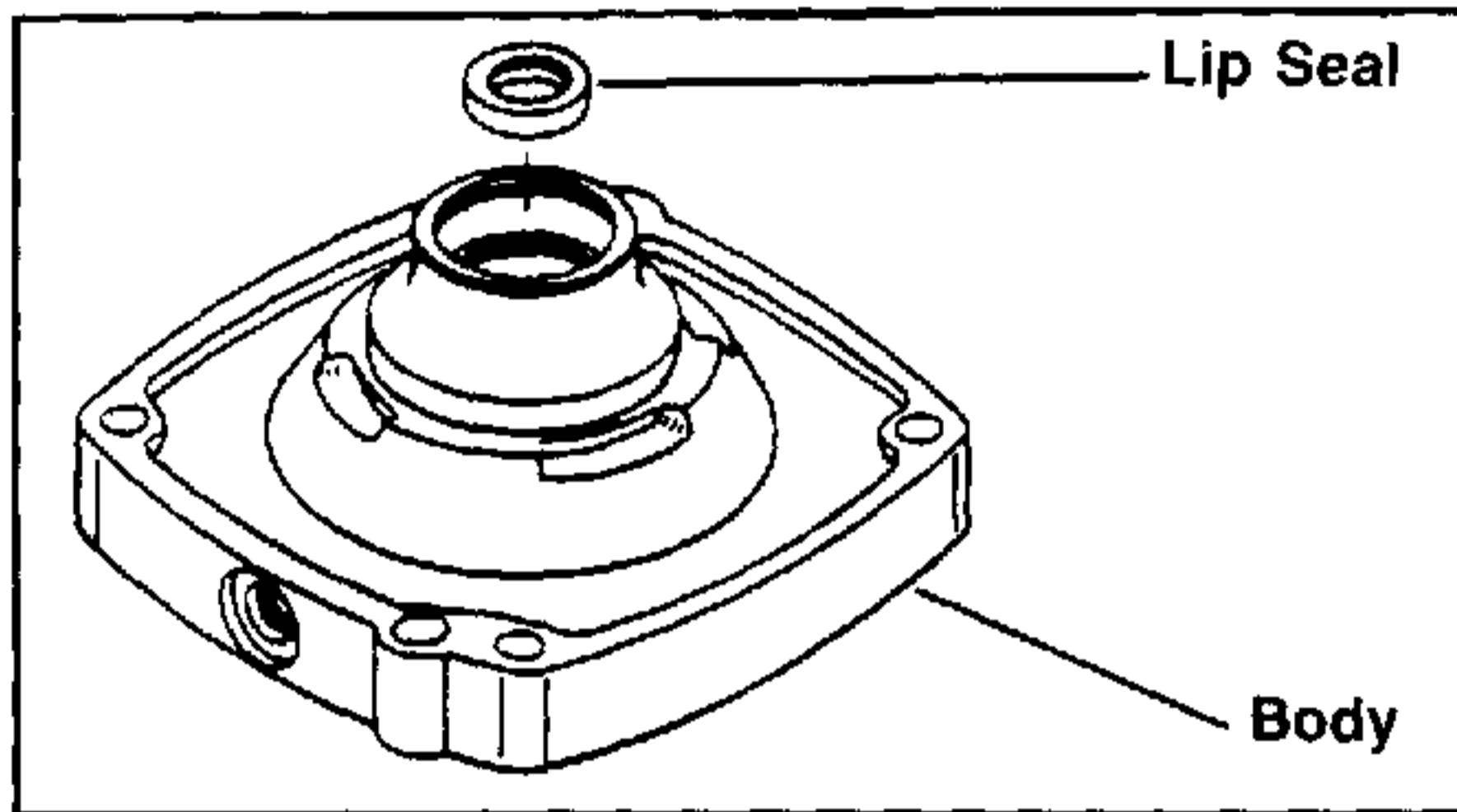

FIGURE 32.

52. Lubricate inner surface of new lip seal and install with the rubber lip of the seal toward the counter bore in body.

Important: Do not over-press or drive the seal; this may damage the rubber sealing portion of the seal or distort counter bore.

53. Install output shaft into body, protecting the shaft seal lip from keyway and snap ring grooves.

Support the output shaft from underneath body so that the cross pin in output shaft is tight against body.

Use a solid block (steel or hardwood) 2 inches in diameter by at least 1½ inches long to support the output shaft.

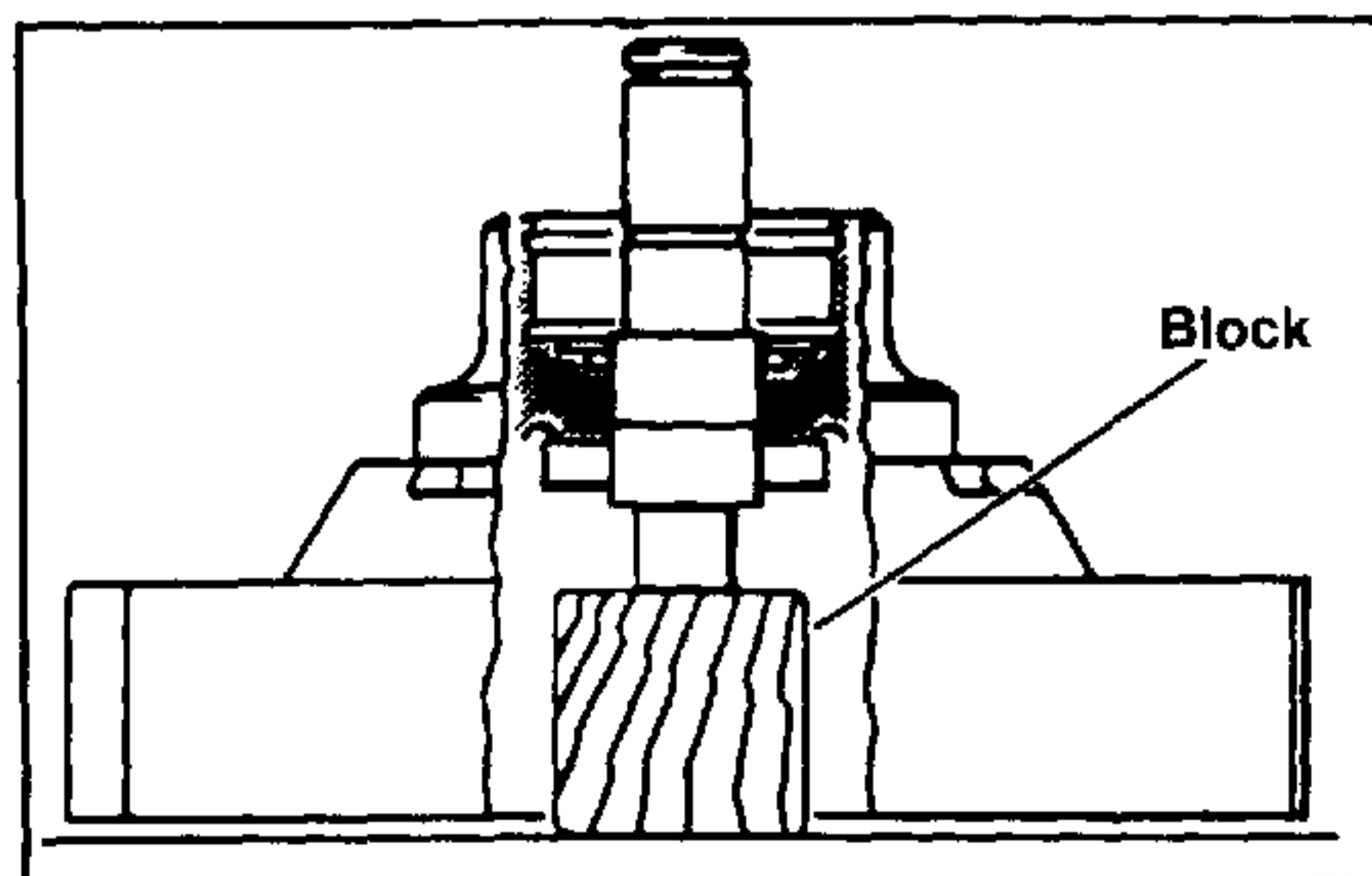

FIGURE 33.

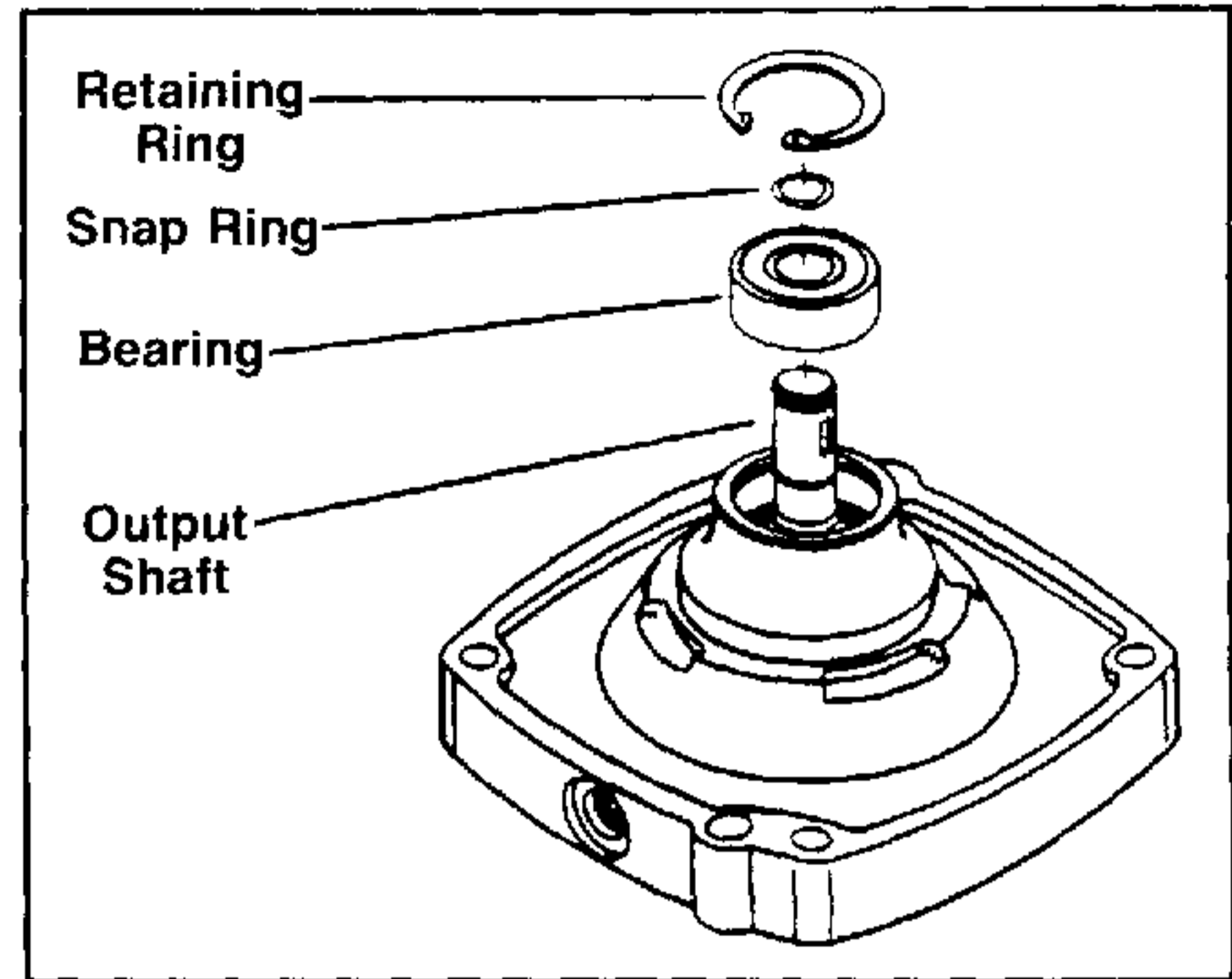

FIGURE 34.

54. Install output shaft bearing by positioning bearing over output shaft and pressing on outer race of ball bearing to the bottom position in body.

55. Install small snap ring on output shaft against inner bearing race.

56. Install the large retaining ring used to retain ball bearing in body.

Note: The output shaft must rotate freely by hand. If it doesn't, recheck bearing installation.

MOTOR ROTOR—INSTALLATION

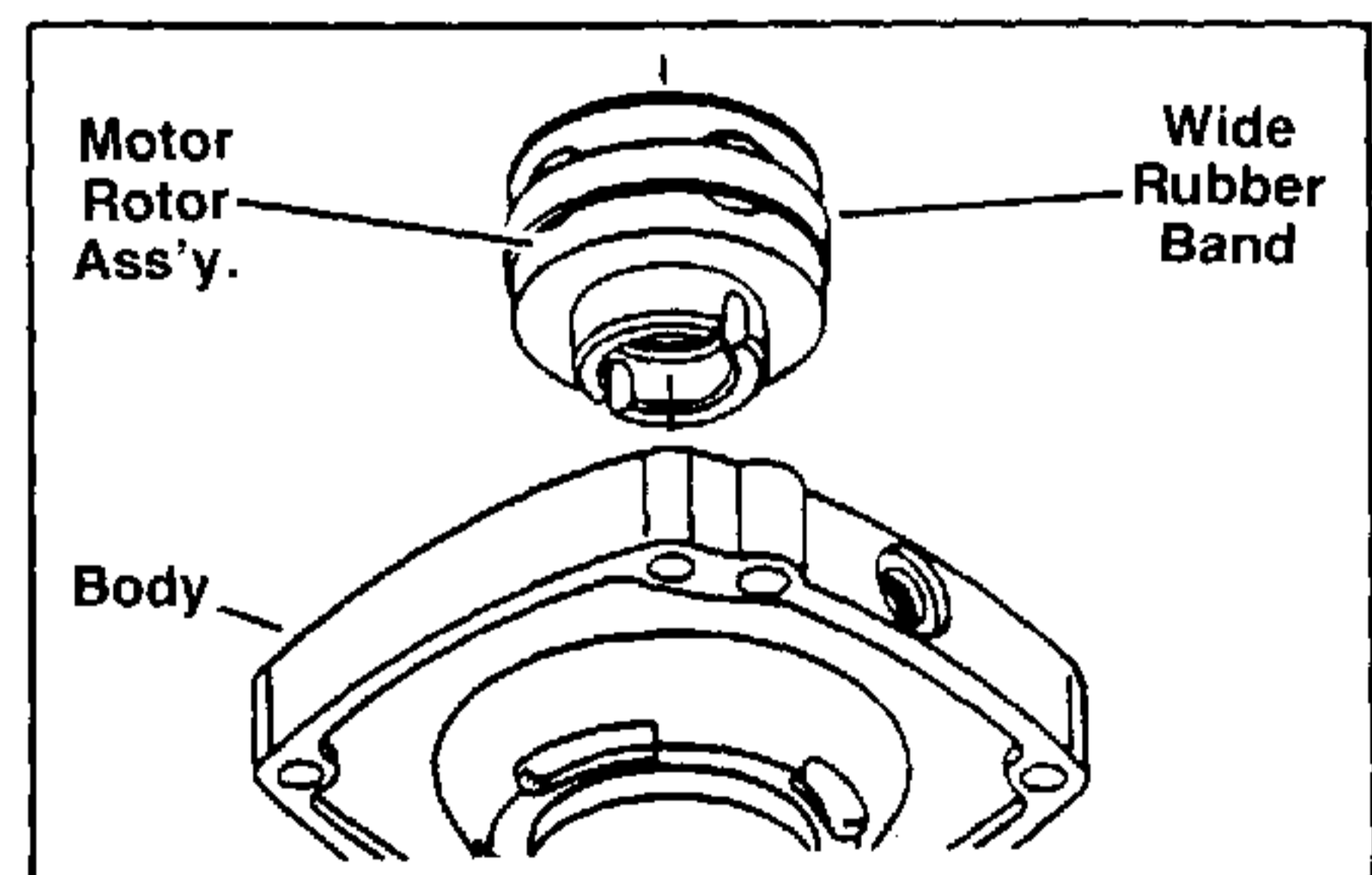

FIGURE 35.

57. Align the slot in the motor rotor assembly with the cross pin on the output shaft and install the motor rotor in body.

58. Remove the rubber band retaining the ball pistons in their respective bores (if used).

COVER/BODY—REASSEMBLY

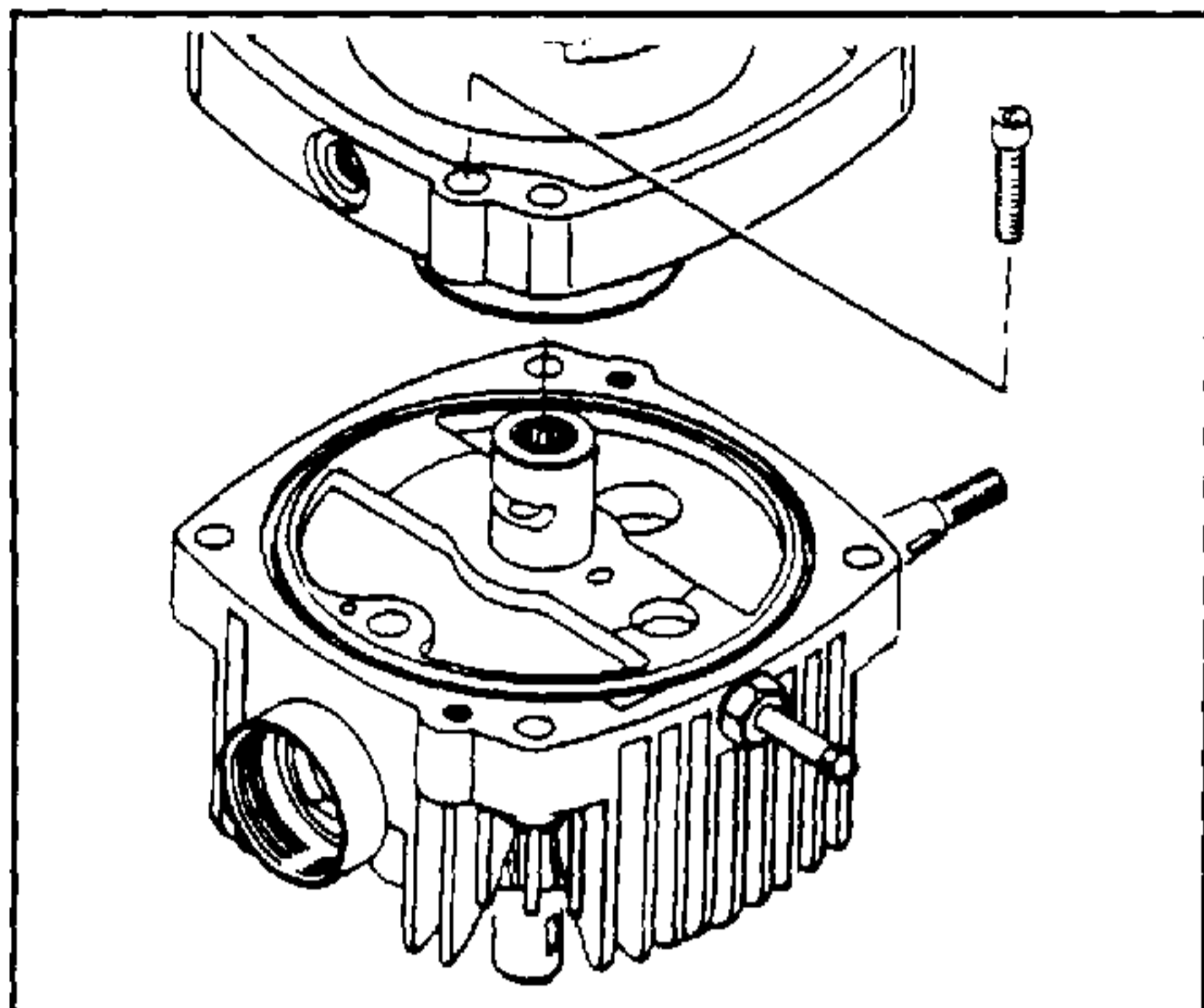

FIGURE 36.

Important: Be sure to realign previous scribed line for correct output rotation. If body assembly is installed 180° as previously assembled, output rotation will be reversed.

59. Hold the motor rotor assembly in position and install body on pintle.

Note: Do not force motor rotor assembly on pintle as it is a slip fit and must turn freely by hand.

60. Install the (2) 5/16 x 1-1/4 socket head cap screws and torque to 15 foot pounds.

RESERVOIR/ADAPTER—REASSEMBLY

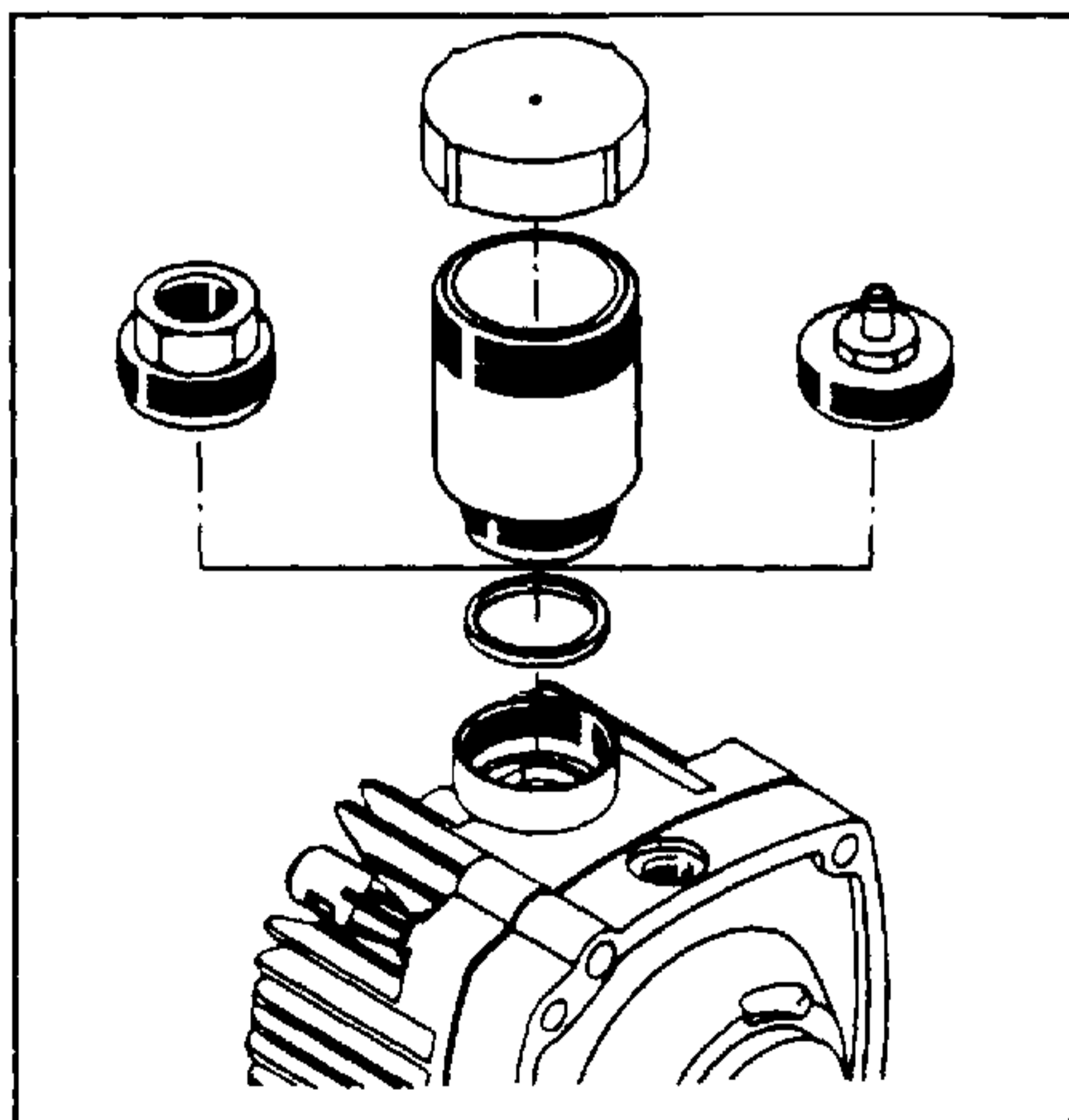

FIGURE 37.

61. Lightly grease sealing ring and install into recess in cover.

62. Install the adapter or reservoir in cover by rotating counterclockwise.

Torque to Approximately 8-12 ft. lbs.

Important: The adapters and reservoir are threaded left hand. To install, turn counterclockwise.

START-UP PROCEDURE

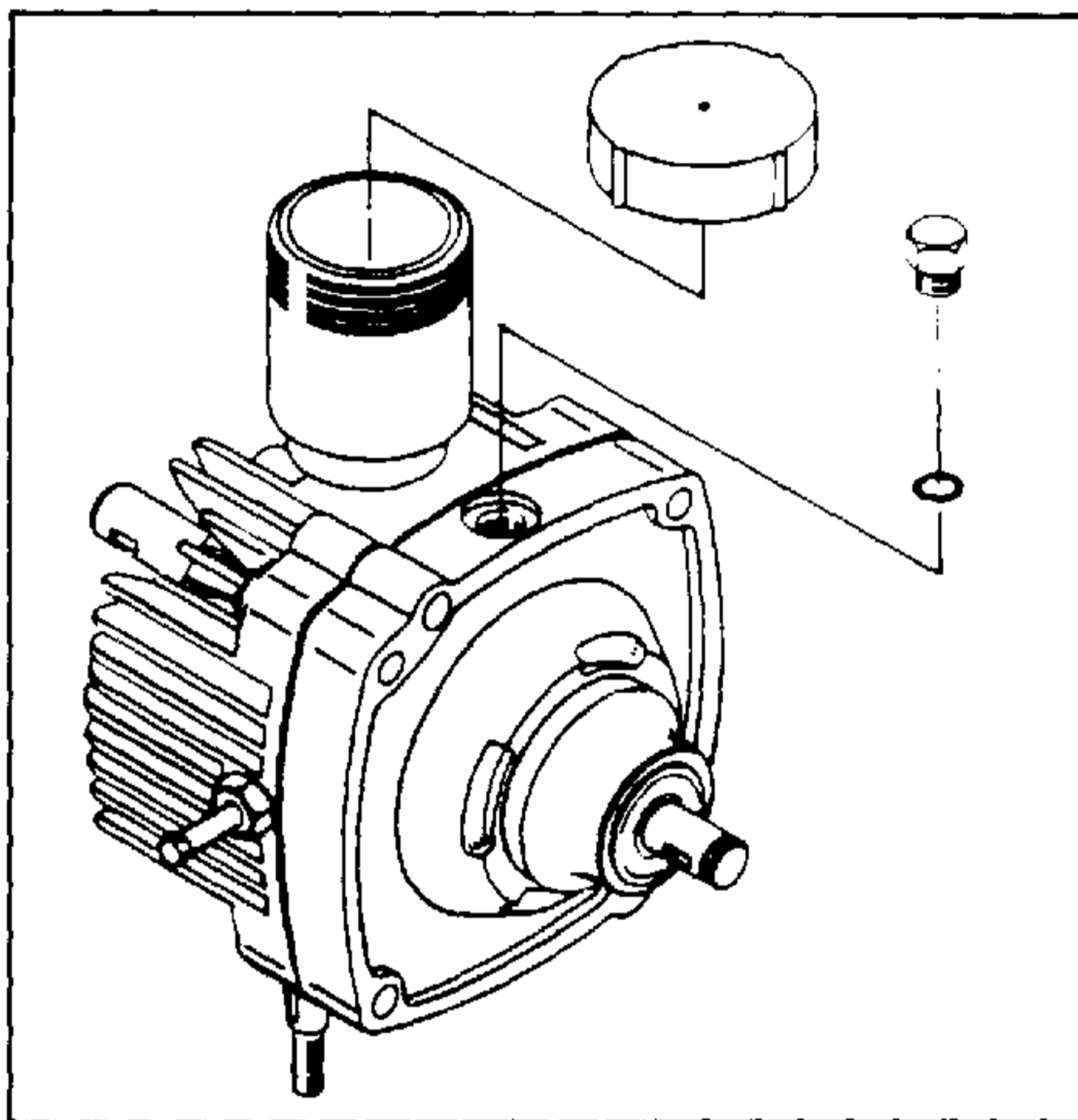

FIGURE 38.

63. Remove the 3/8 hex head plug to vent the transmission. See page 16 for fluid recommendations.

ATTACHED RESERVOIR

Fill the transmission with the proper fluid through reservoir until fluid overflows from opening in body.

Rotate both the input and output shafts to purge any trapped air from transmission. Refill reservoir until fluid reappears and install hex head plug. **Torque to 2-5 Foot Pounds.**

Fill reservoir to oil level cold mark.

SEPARATE RESERVOIR

Fill the transmission with the proper fluid through customer supplied separate reservoir until fluid overflows from opening in body.

Rotate both the input and output shafts to purge any trapped air from transmission. Refill reservoir until fluid reappears and install hex head plug. **Torque to 2-5 Foot Pounds.**

Fill reservoir to proper fluid level shown.

**DISASSEMBLY AND ASSEMBLY
HYDROSTATIC TRANSMISSIONS**

SUNDSTRAND

MODEL

BDU-10S-110

BDU-10S-115

BDU-10S-210

BDU-10S-213

BDU-10S-114

TABLE OF CONTENTS

	PAGE
1. Introduction	2-44
2. Disassembly	2-45
3. Assembly	2-55
4. Repair Parts List	2-69

1. INTRODUCTION

The procedures on the following pages are for disassembly and assembly of the hydrostatic transmission BDU-10S.

Cleanliness is the primary means of insuring satisfactory transmission life.

Take care to clean parts when assembling them.

And, pay attention to protect each part, especially all exposed sealing surfaces, from damage.

DISASSEMBLY

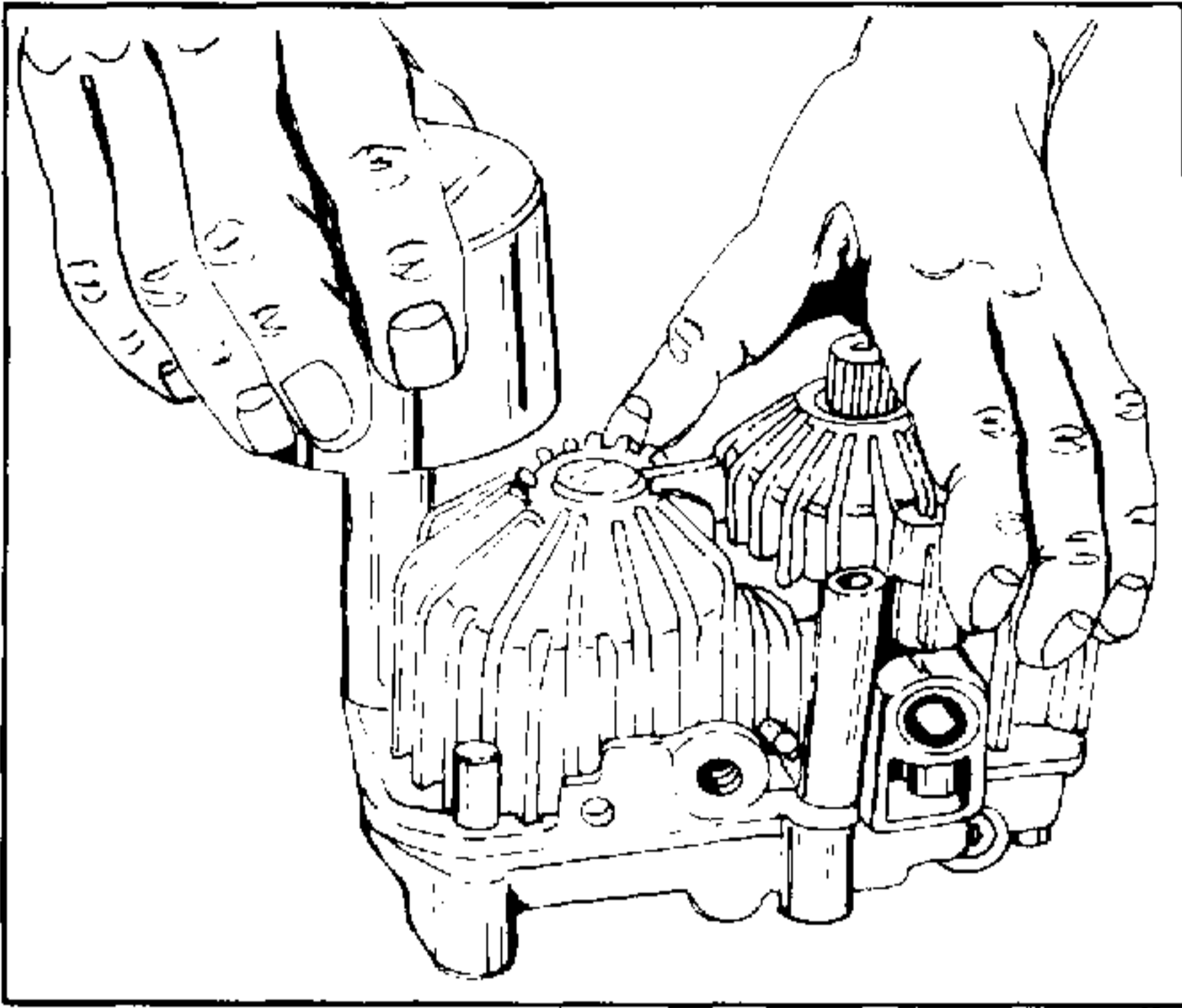

FIGURE 1.

1. Oil tank assembly
 - 1.1 Unscrew the cap.
(This cap has a left-handed thread.)

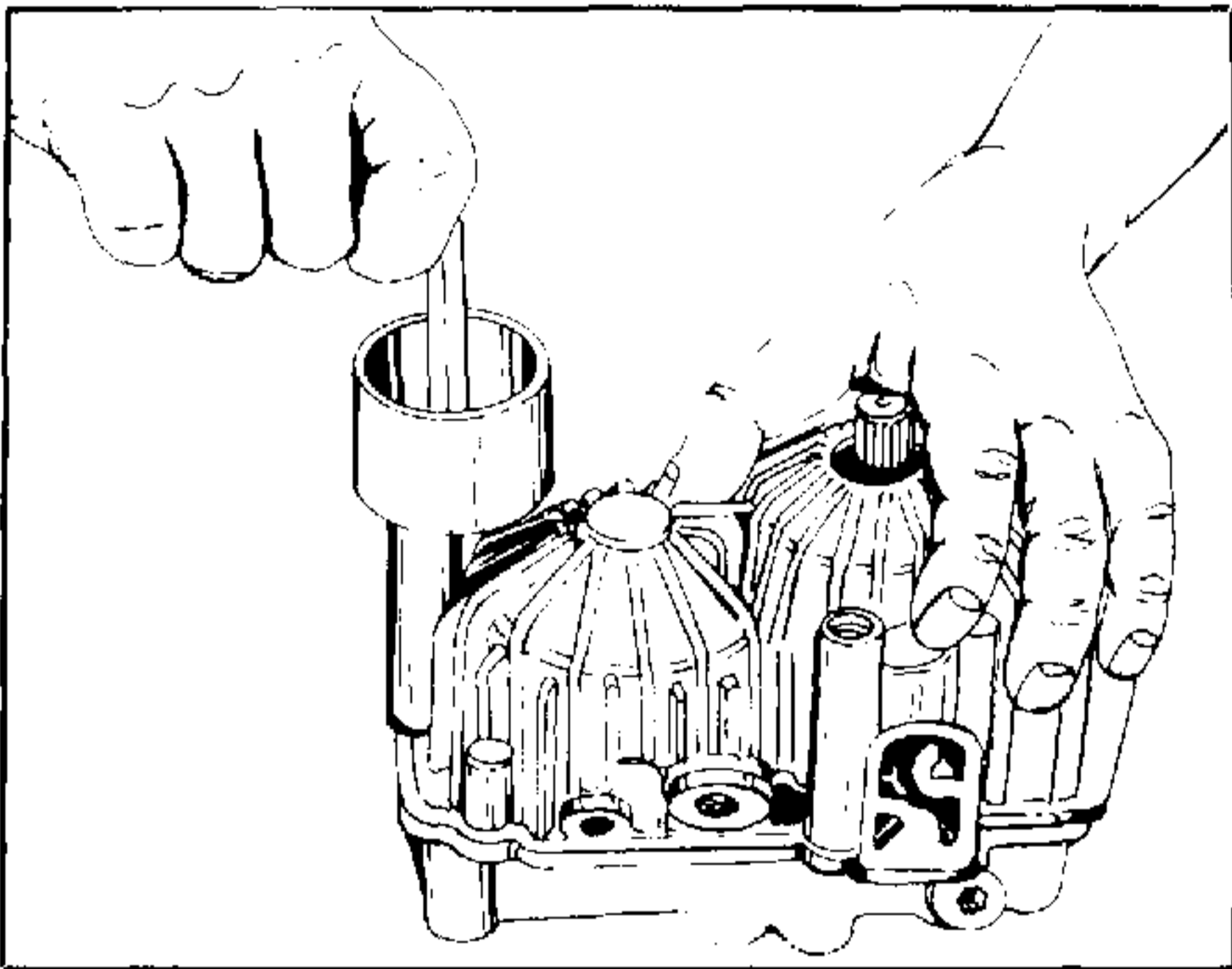

FIGURE 2.

- 1.2 Unscrew the oil tank.
TOOL: HEX SOCKET SCREW KEY

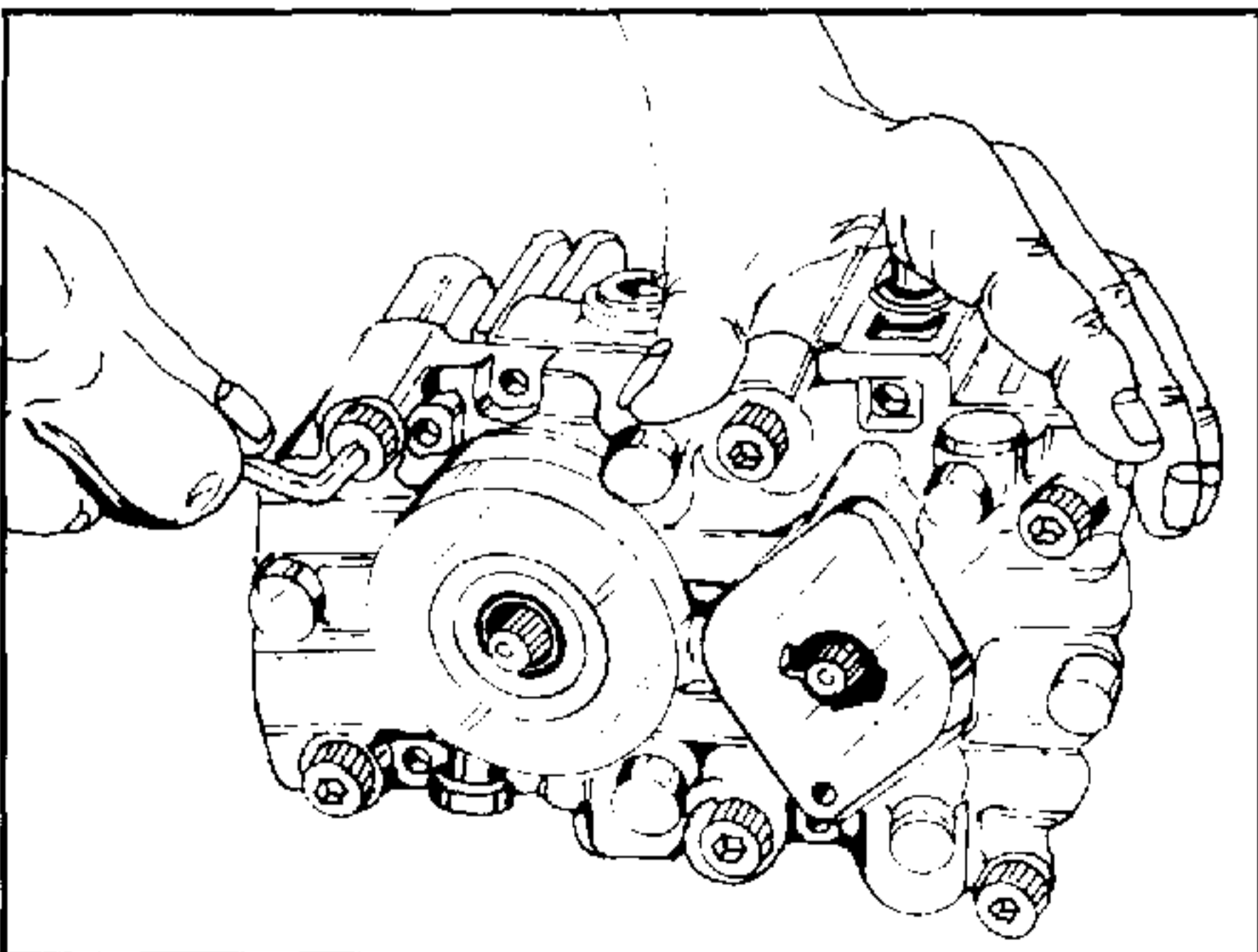

FIGURE 3.

2. Center section
 - 2.1 Remove the flat head screws.
SCREW—FLAT HD. M8 x 35 QTY 4
M8 x 20 QTY 4
TOOL: HEX SOCKET SCREW KEY

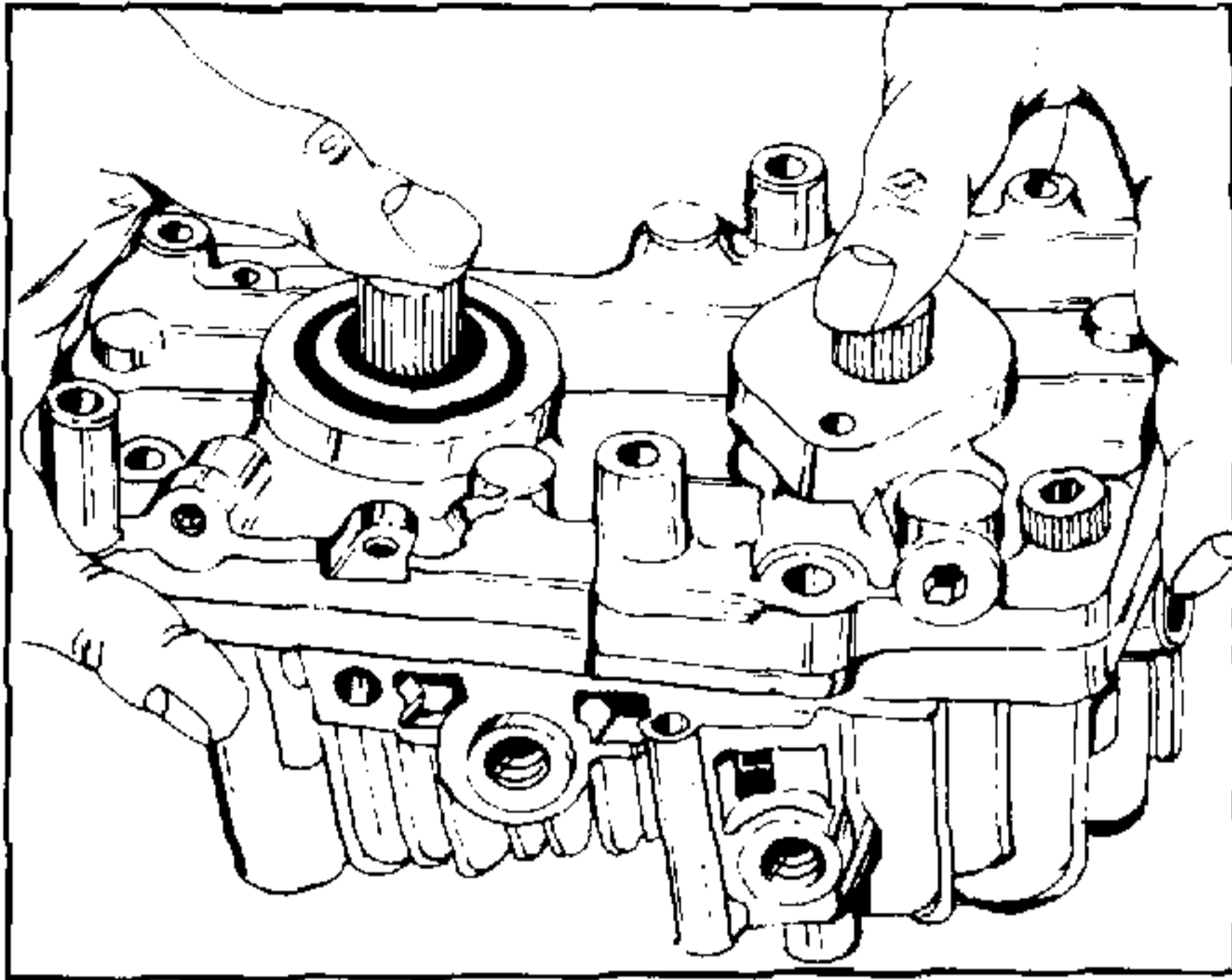

FIGURE 4.

2.2 Lift the center section off the transmission.
Take care not to damage the surface of the
center section and cylinder blocks.

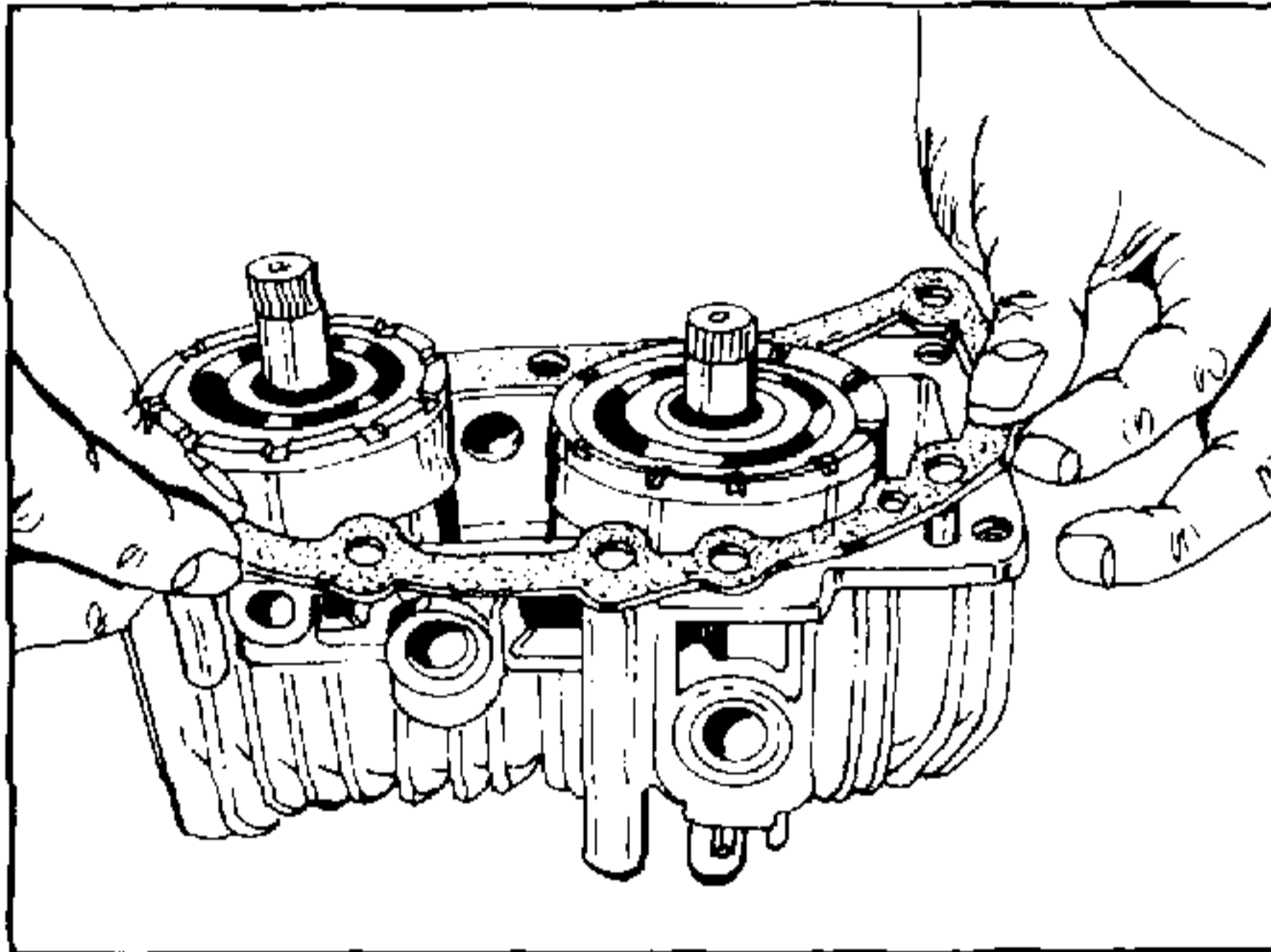

FIGURE 5.

2.3 Remove the gasket.

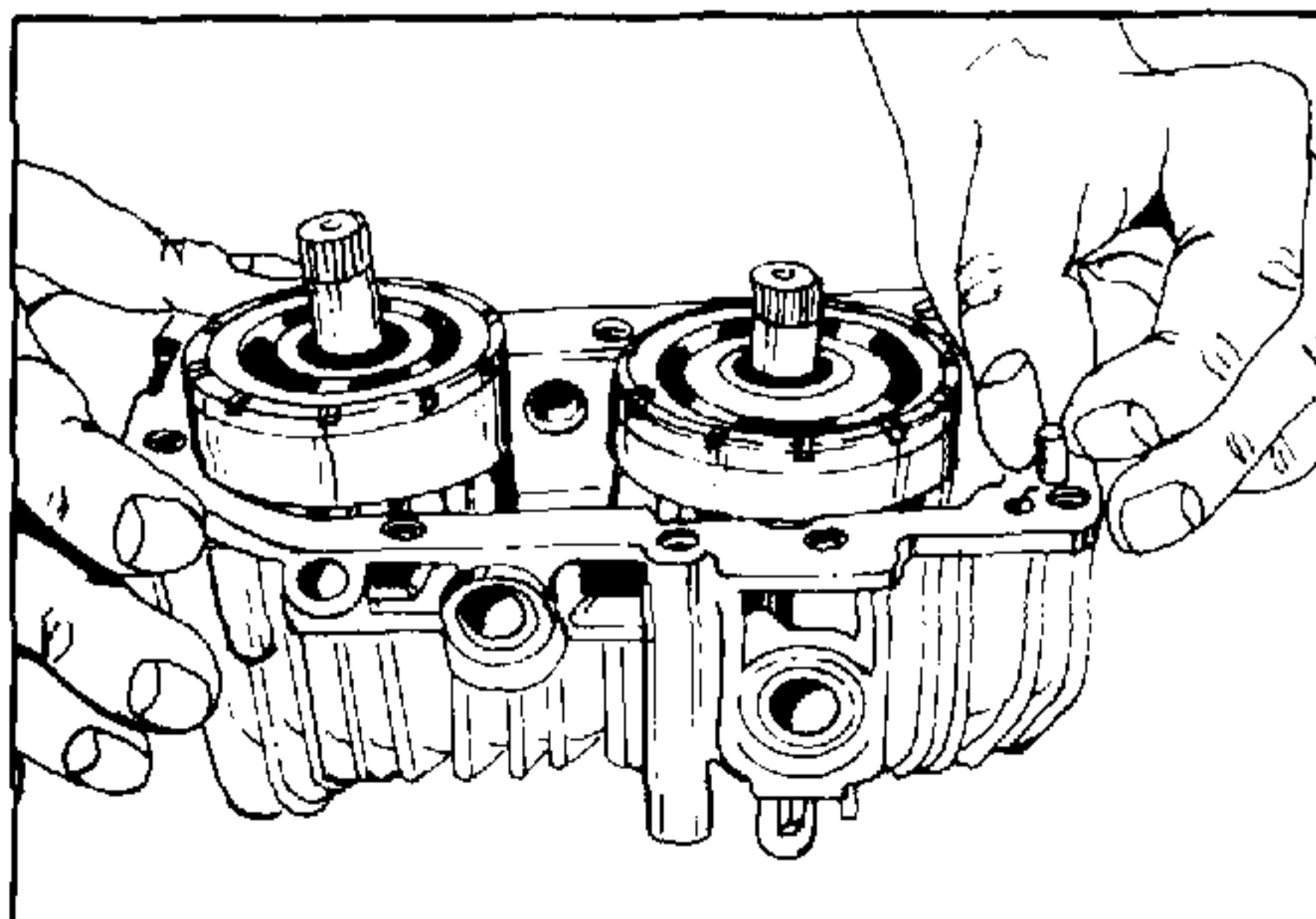

FIGURE 6.

2.4 Remove locating pins.
LOCATING PIN QTY 2

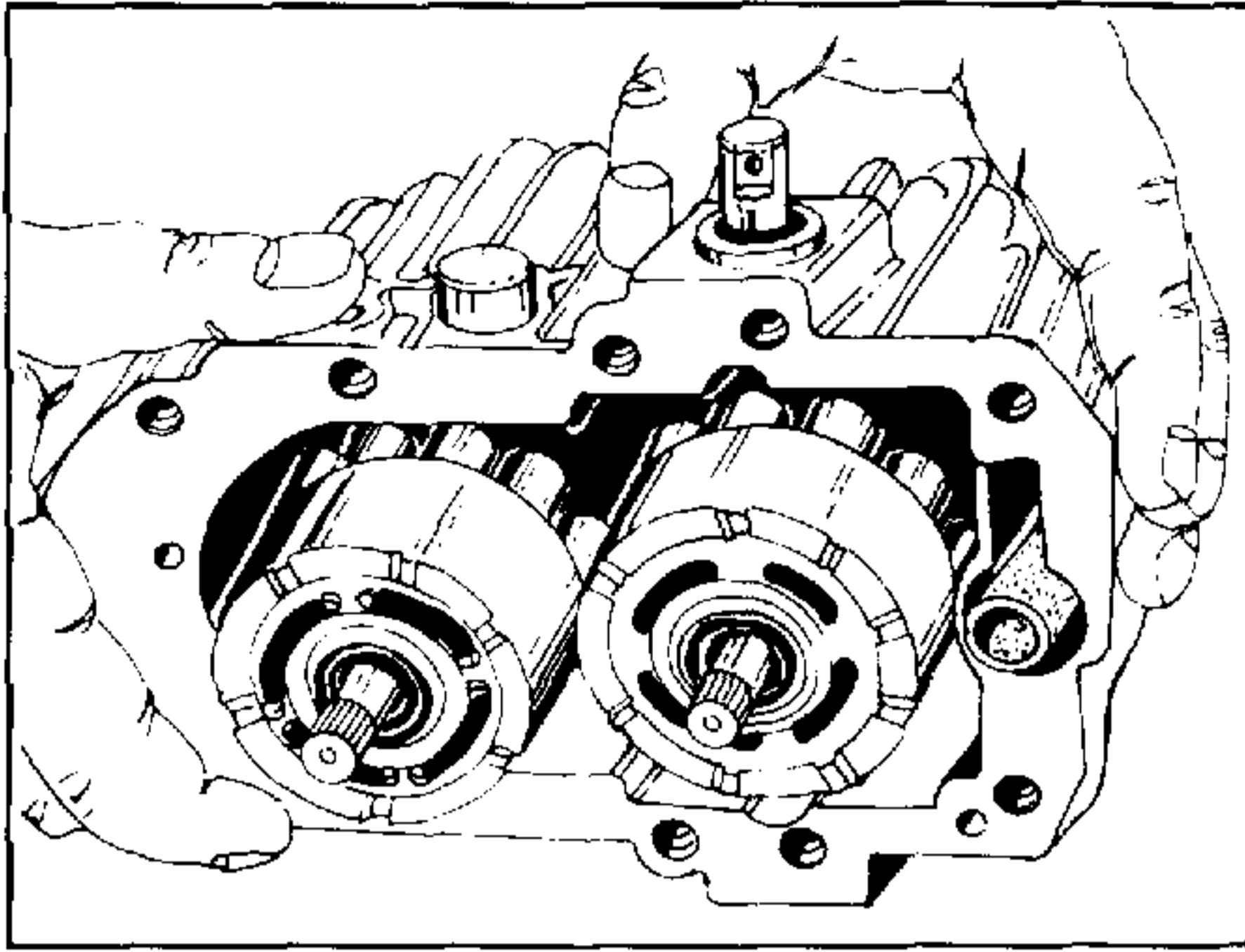

FIGURE 7.

3. Cylinder block kit, Thrust ball bearing.

3.1 Lay the housing on its side.

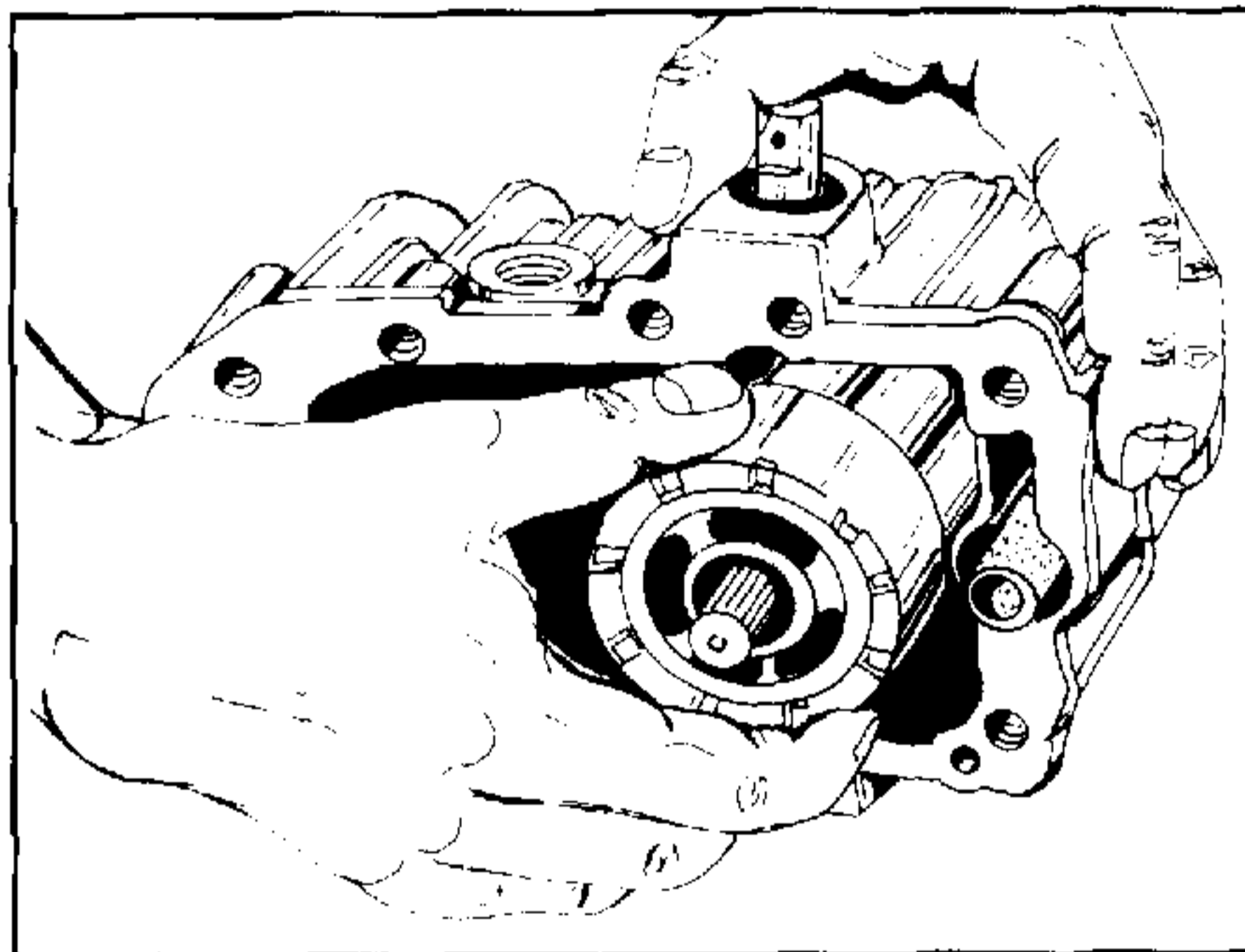

FIGURE 8.

3.2 Slide out cylinder block kits (pump, motor).

The motor shaft is slid out with the cylinder block kit.

Take care not to damage the surface of cylinder blocks.

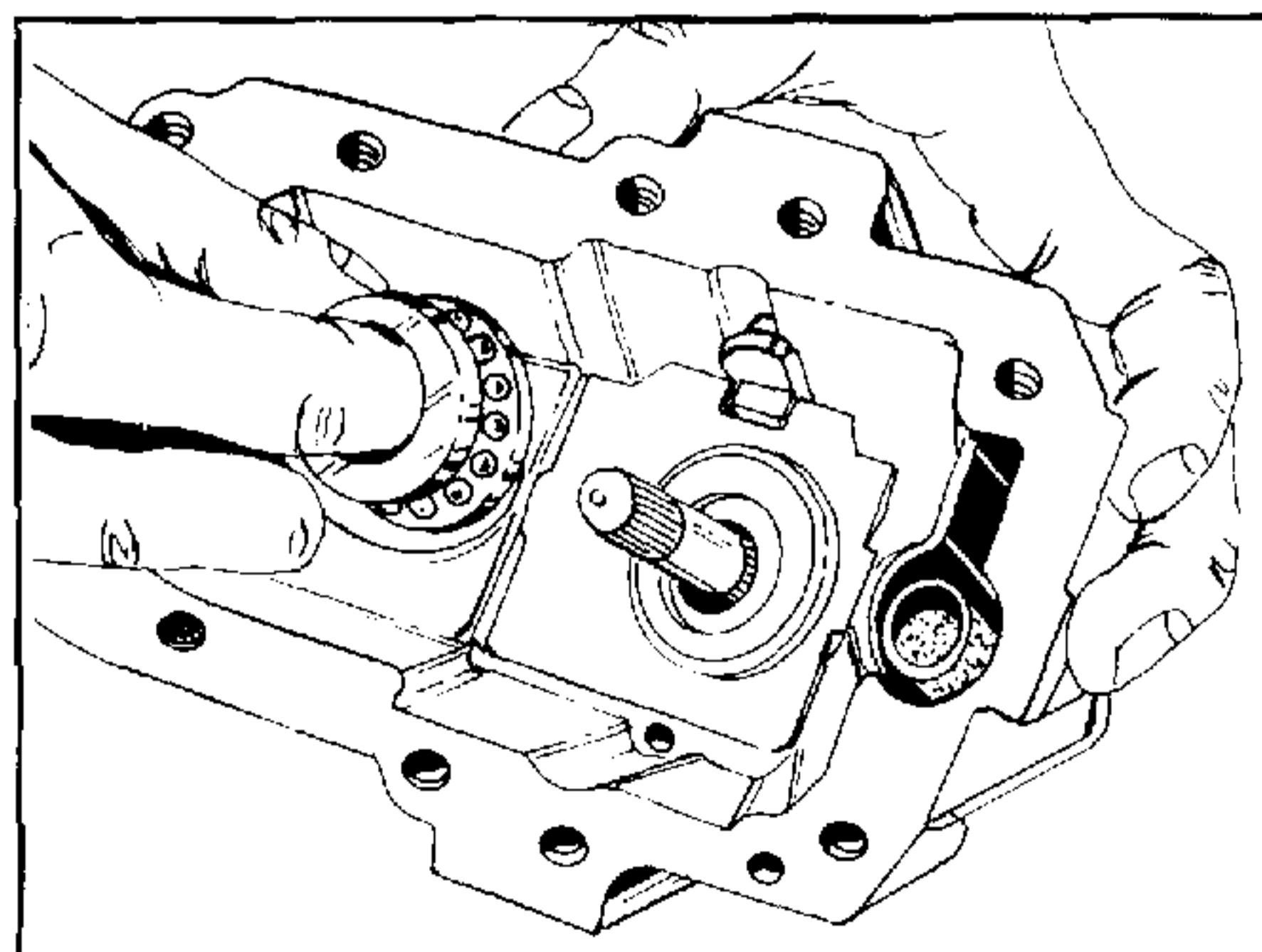

FIGURE 9.

3.3 Remove the thrust ball bearing (motor).

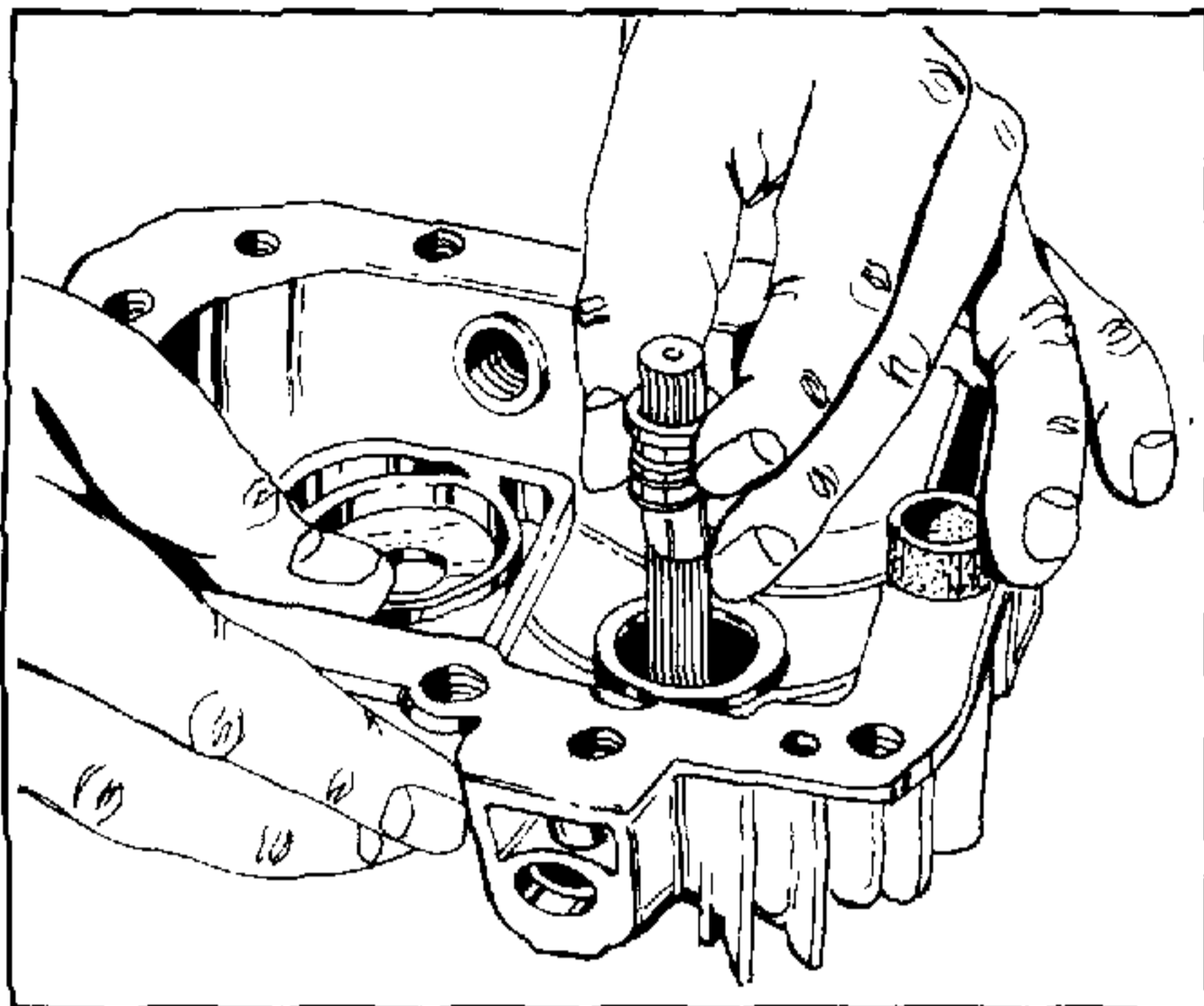

FIGURE 10.

4. Swashplate, Filter

4.1 Remove the spring and the washer.

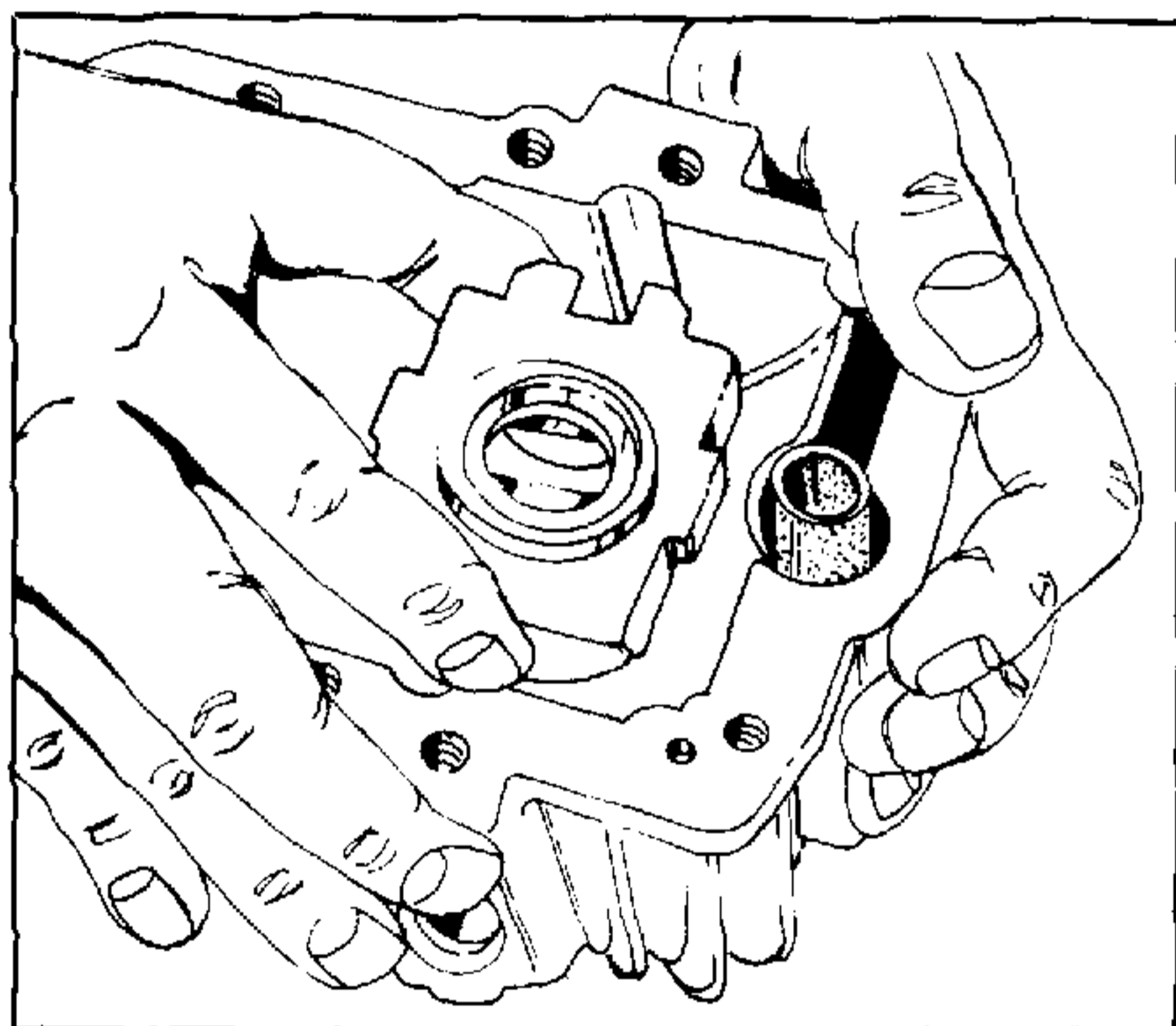

FIGURE 11.

4.2 Remove the swashplate from the housing.

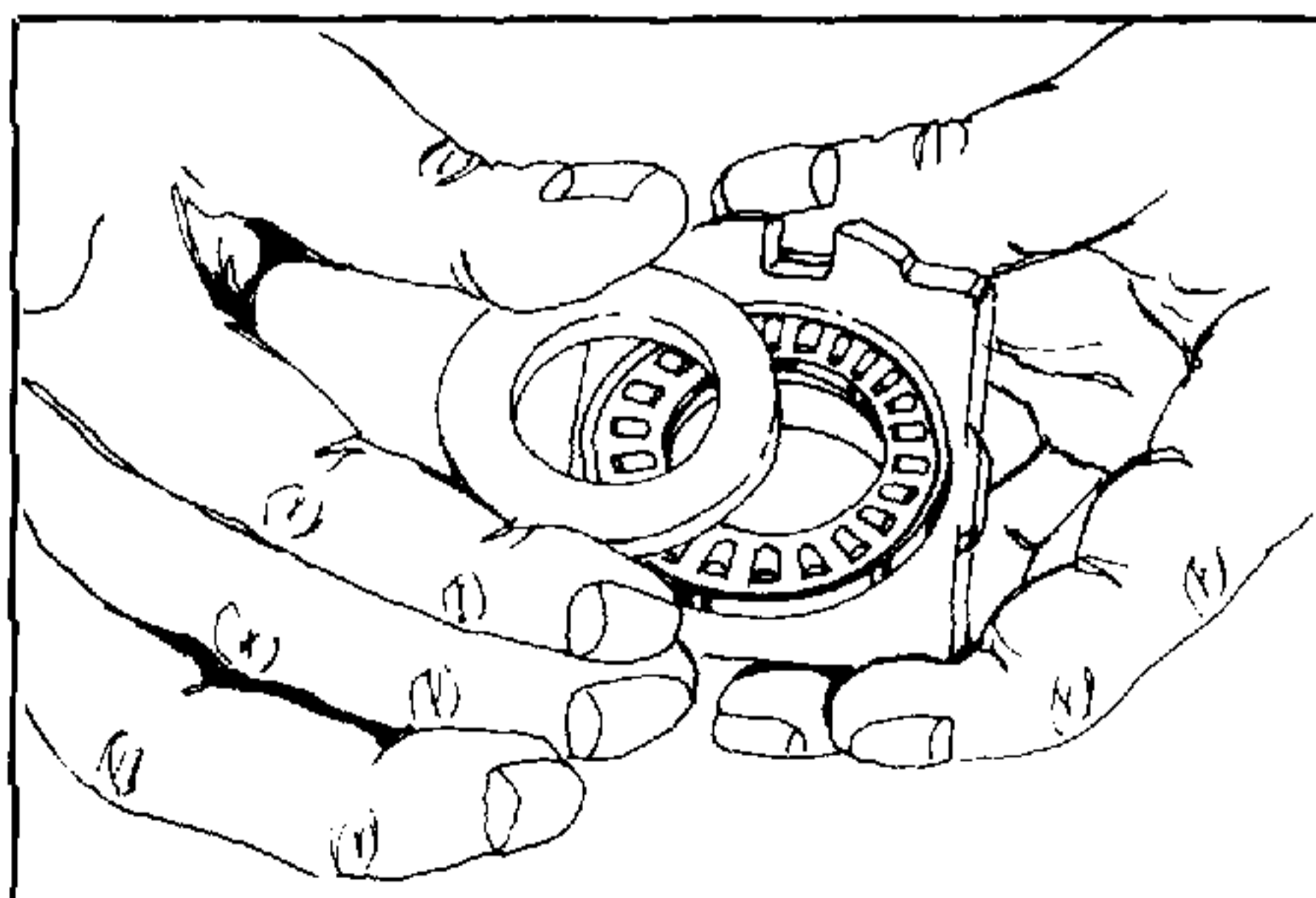

FIGURE 12.

4.3 Remove the thrust plate and the thrust roller from the swashplate.

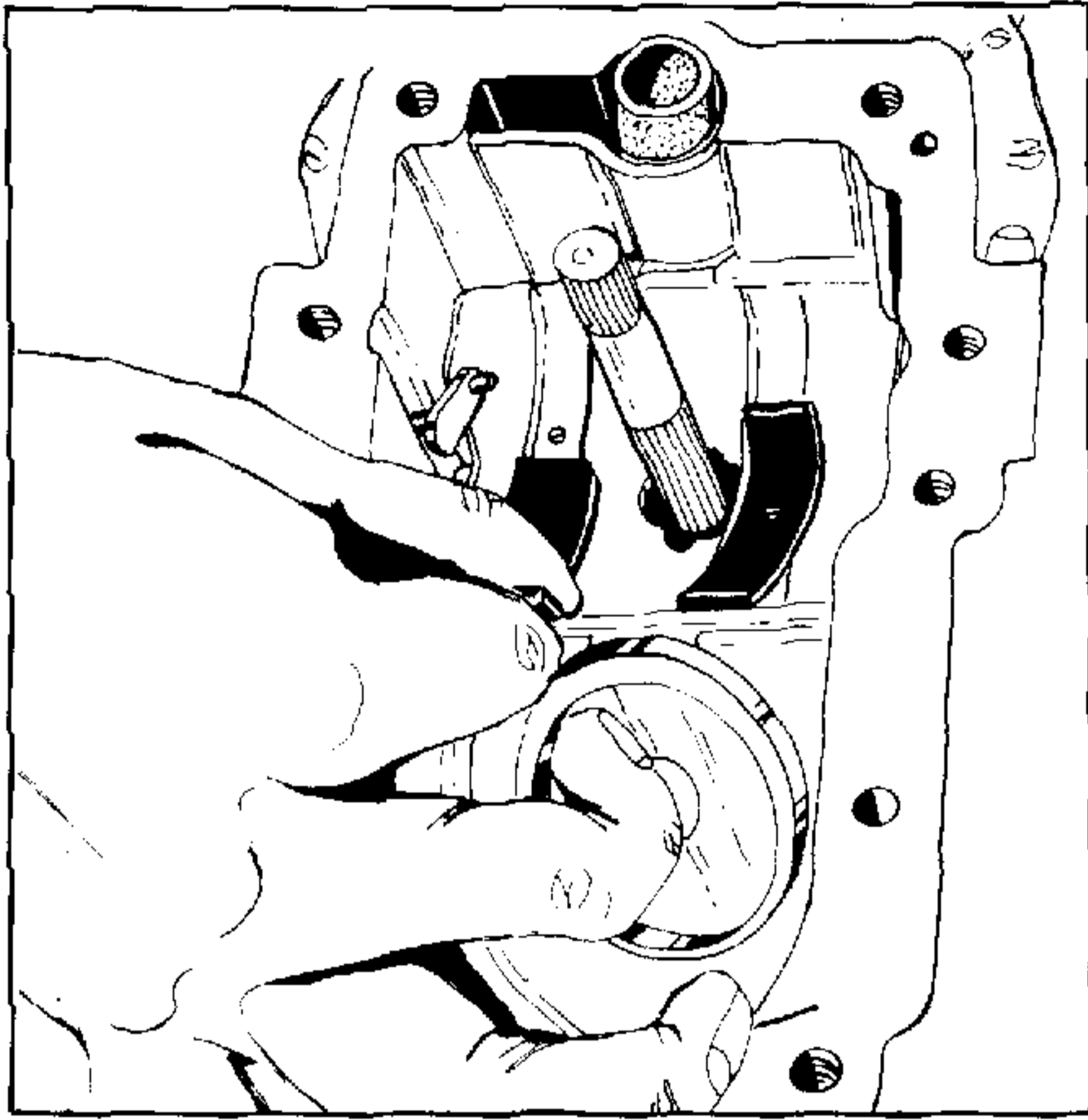

FIGURE 13.

4.4 Remove the slot guide and cradle bearings.

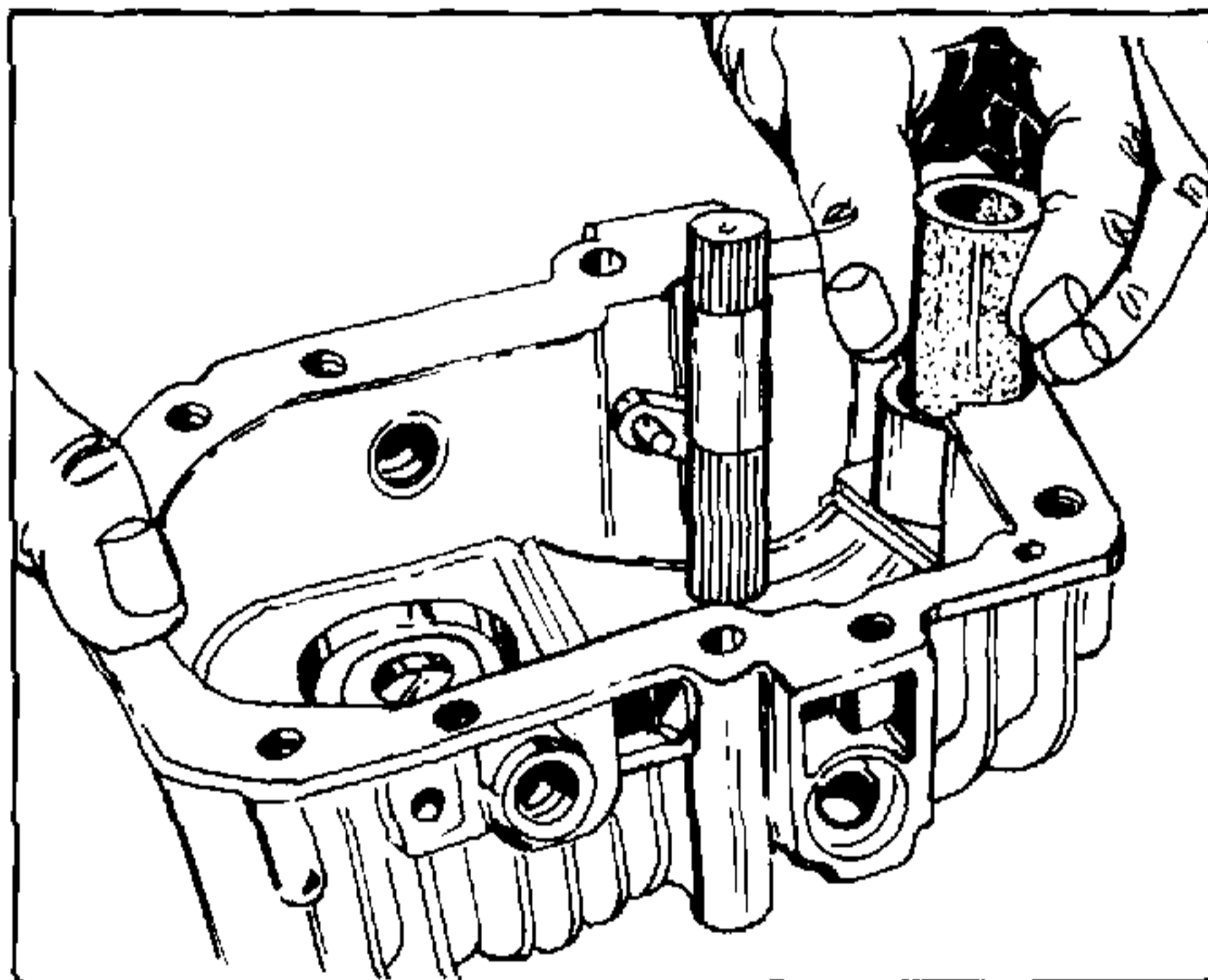

FIGURE 14.

4.5 Remove the filter, washer and the spring.

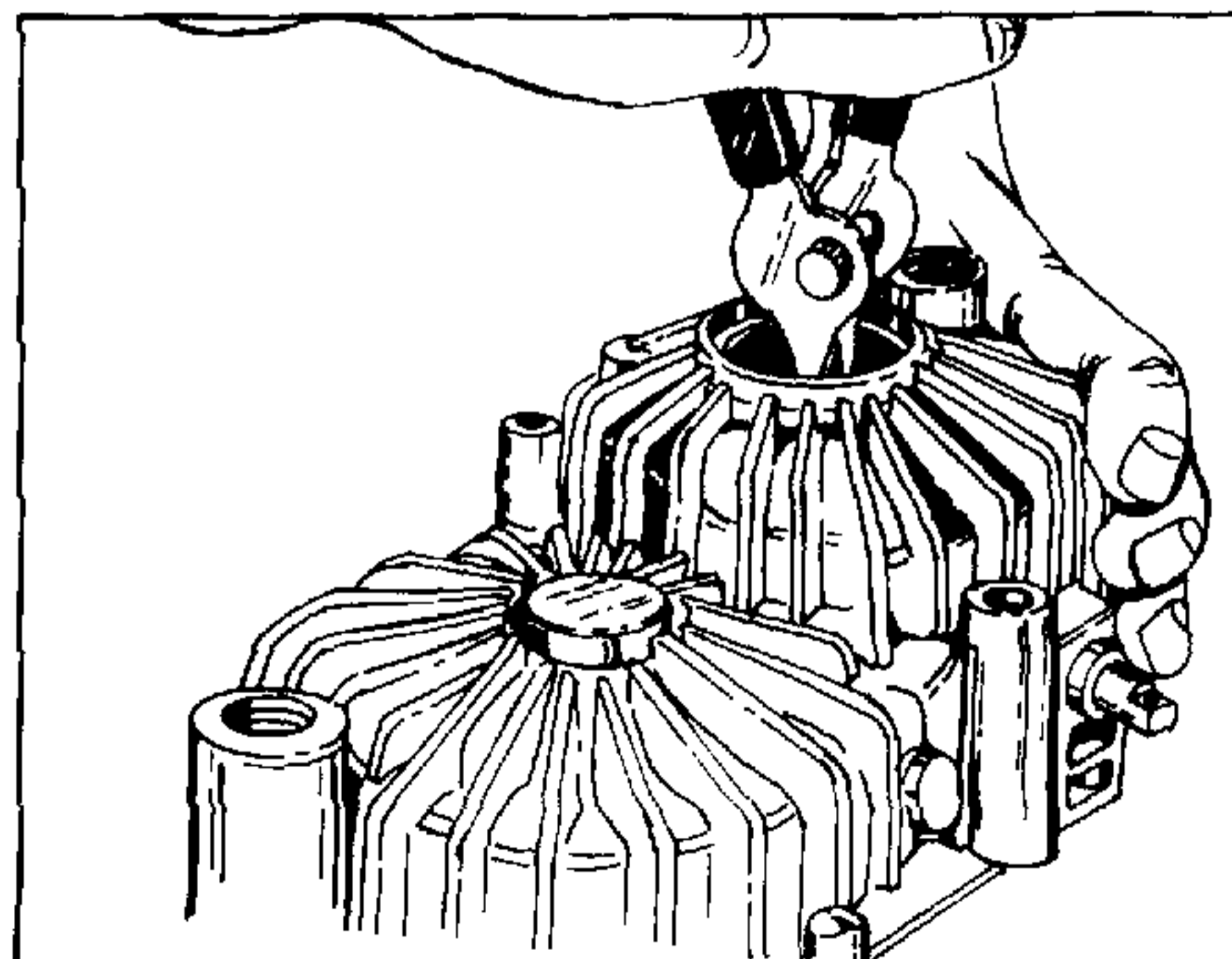

FIGURE 15.

5. Pump shaft, Trunnion arm

5.1 Remove the retaining ring.
 RETAINING RING: FOR HOLE 35
 TOOL: PLIER

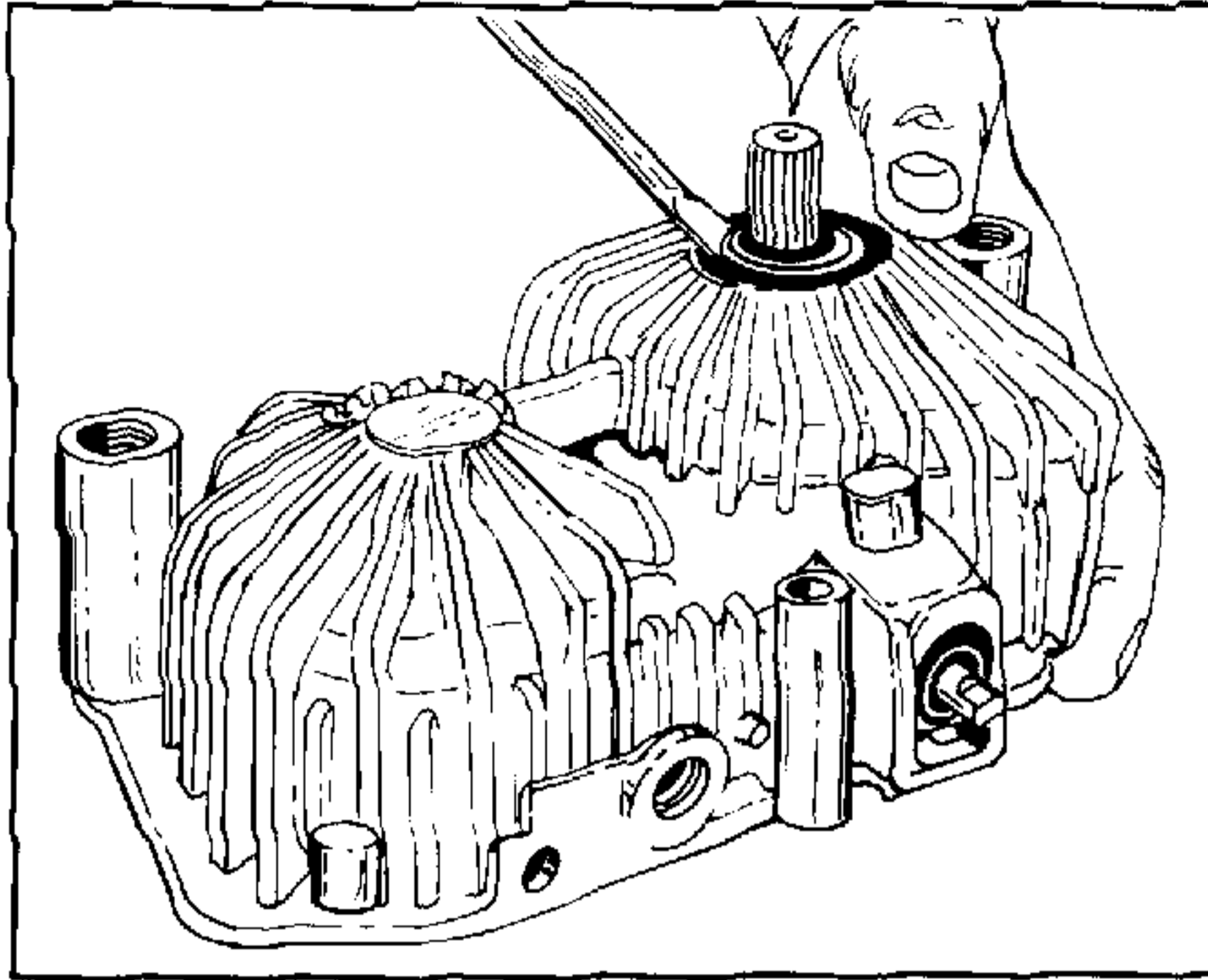

FIGURE 16.

5.2 Puncture the oil seal with a screwdriver, and pry it out with screwdriver.

Take care not to damage the shaft and the housing.

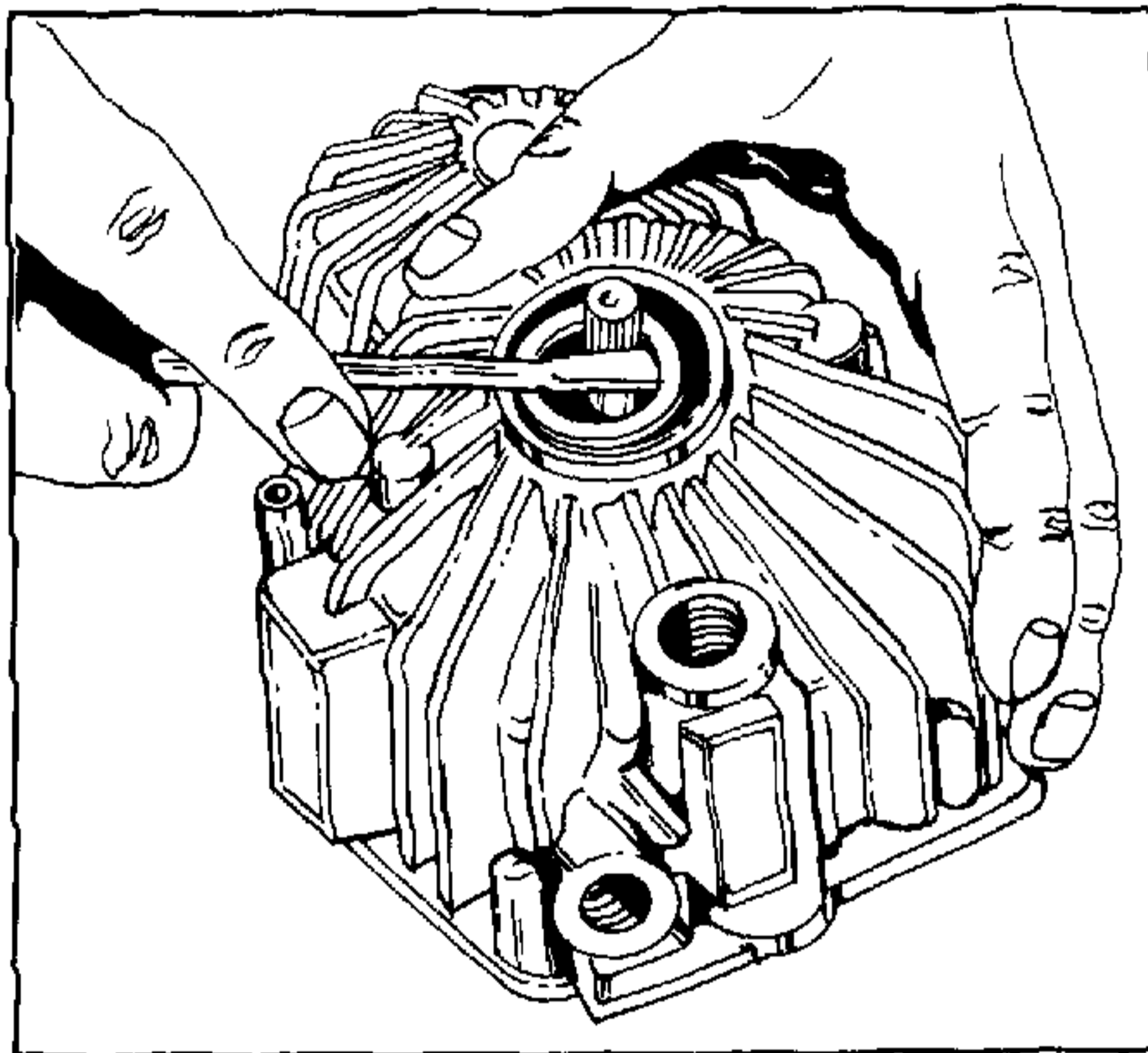

FIGURE 17.

5.3 Remove the spacer.

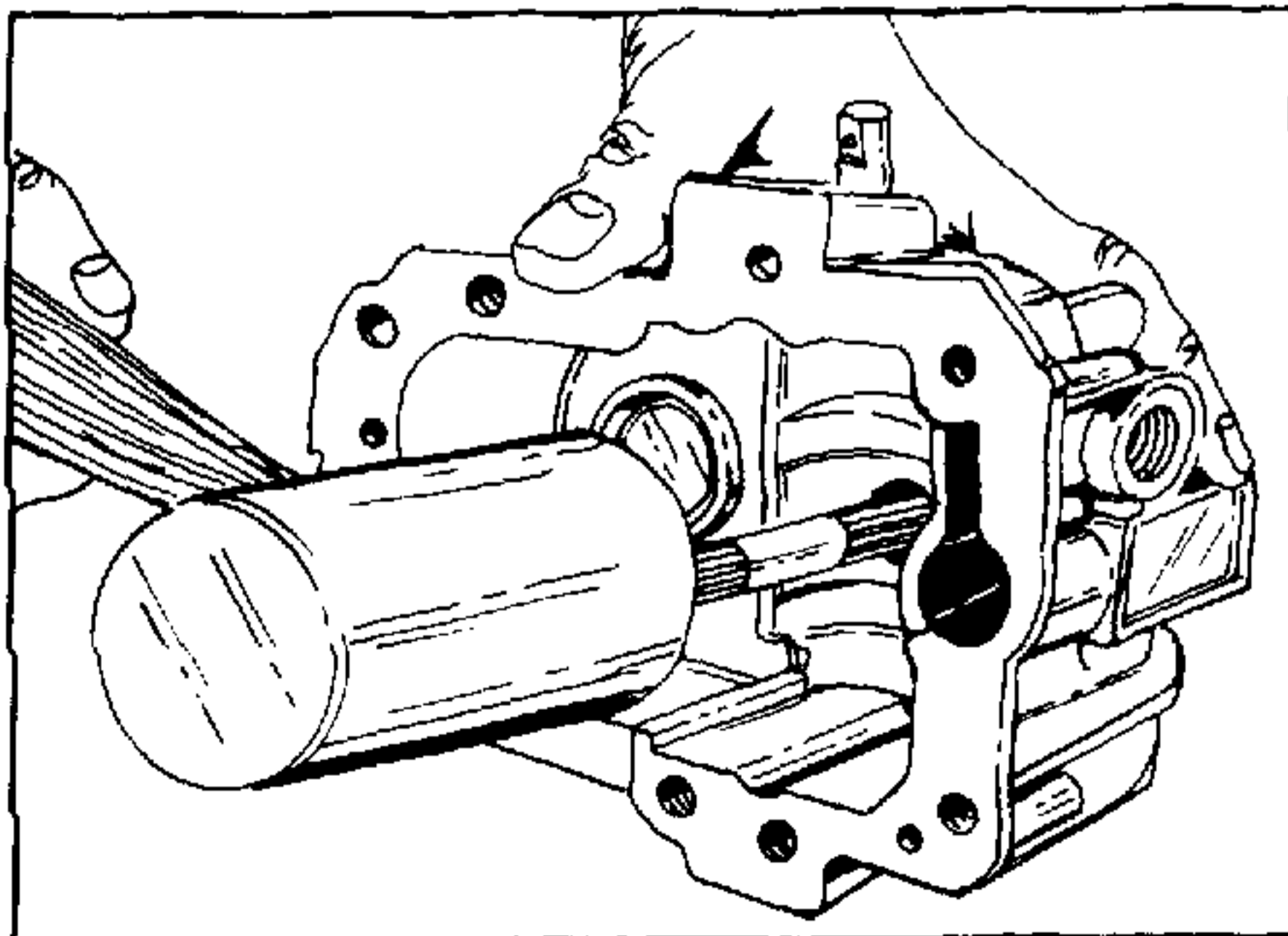

FIGURE 18.

5.4 Tap the end of the pump shaft with a soft hammer lightly to slide it out from the housing.

TOOL: SOFT HAMMER

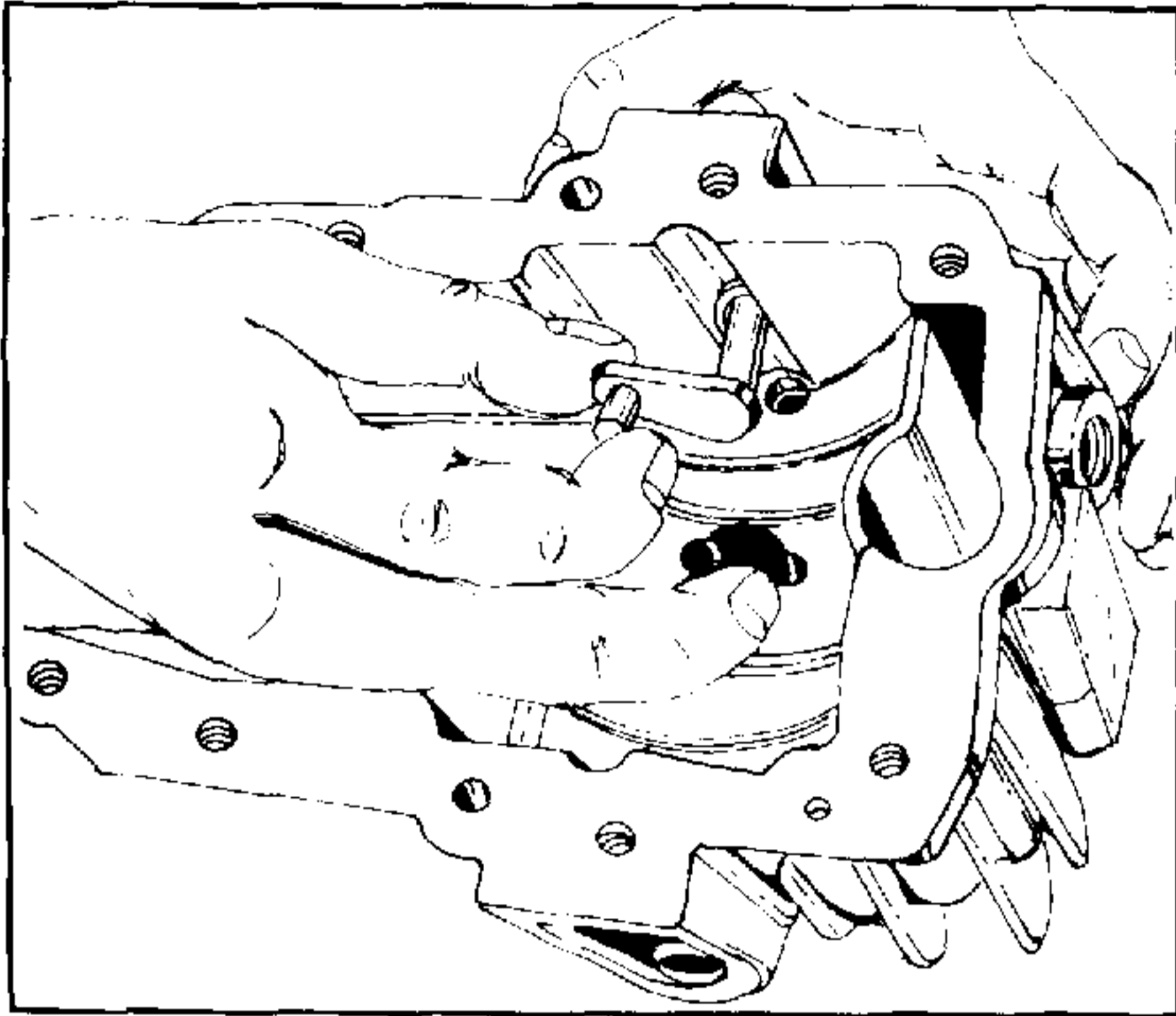

FIGURE 19.

5.5 Remove the trunnion arm.

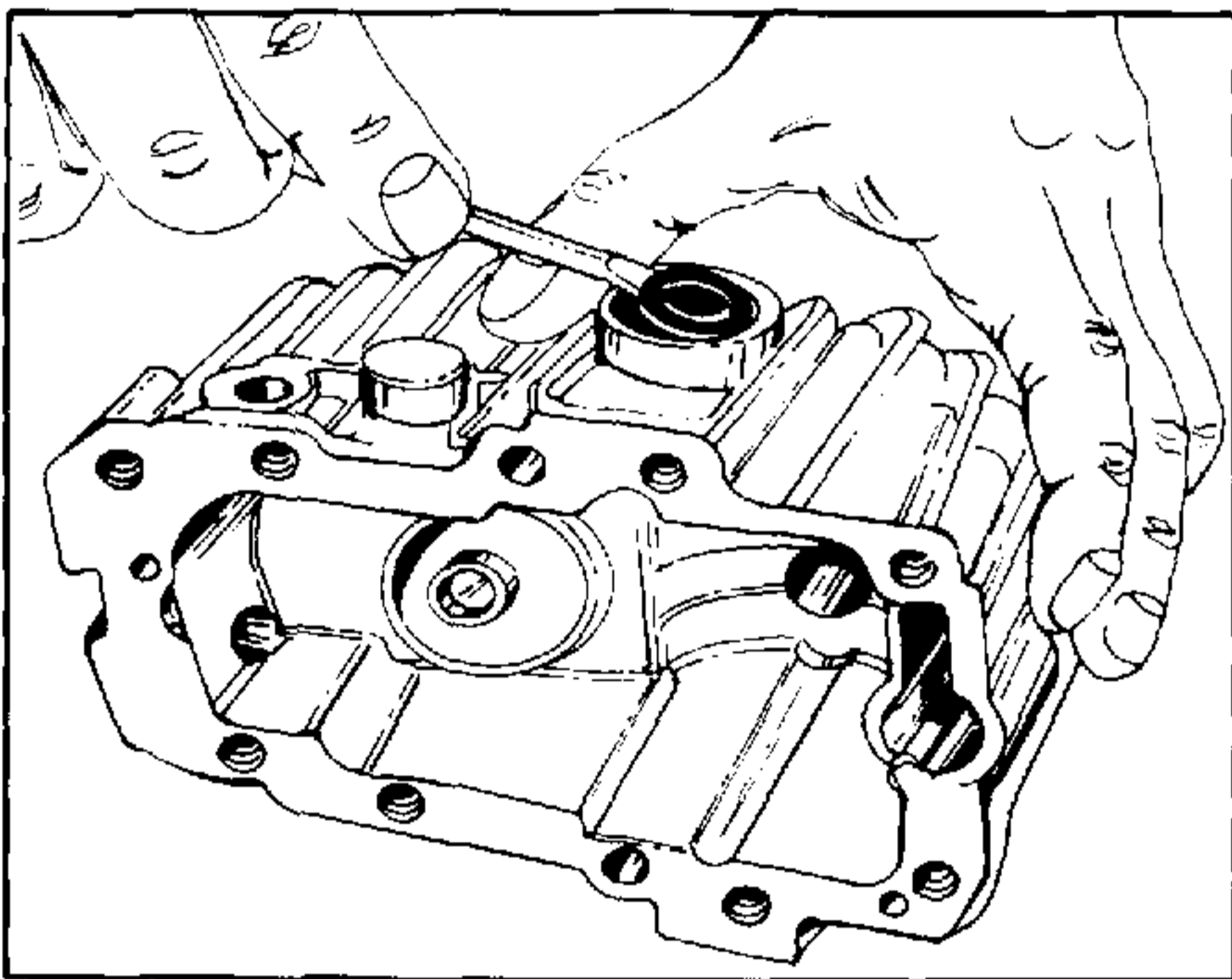

FIGURE 20.

5.6 Pry the oil seal out with screwdriver.
Take care not to damage the housing.

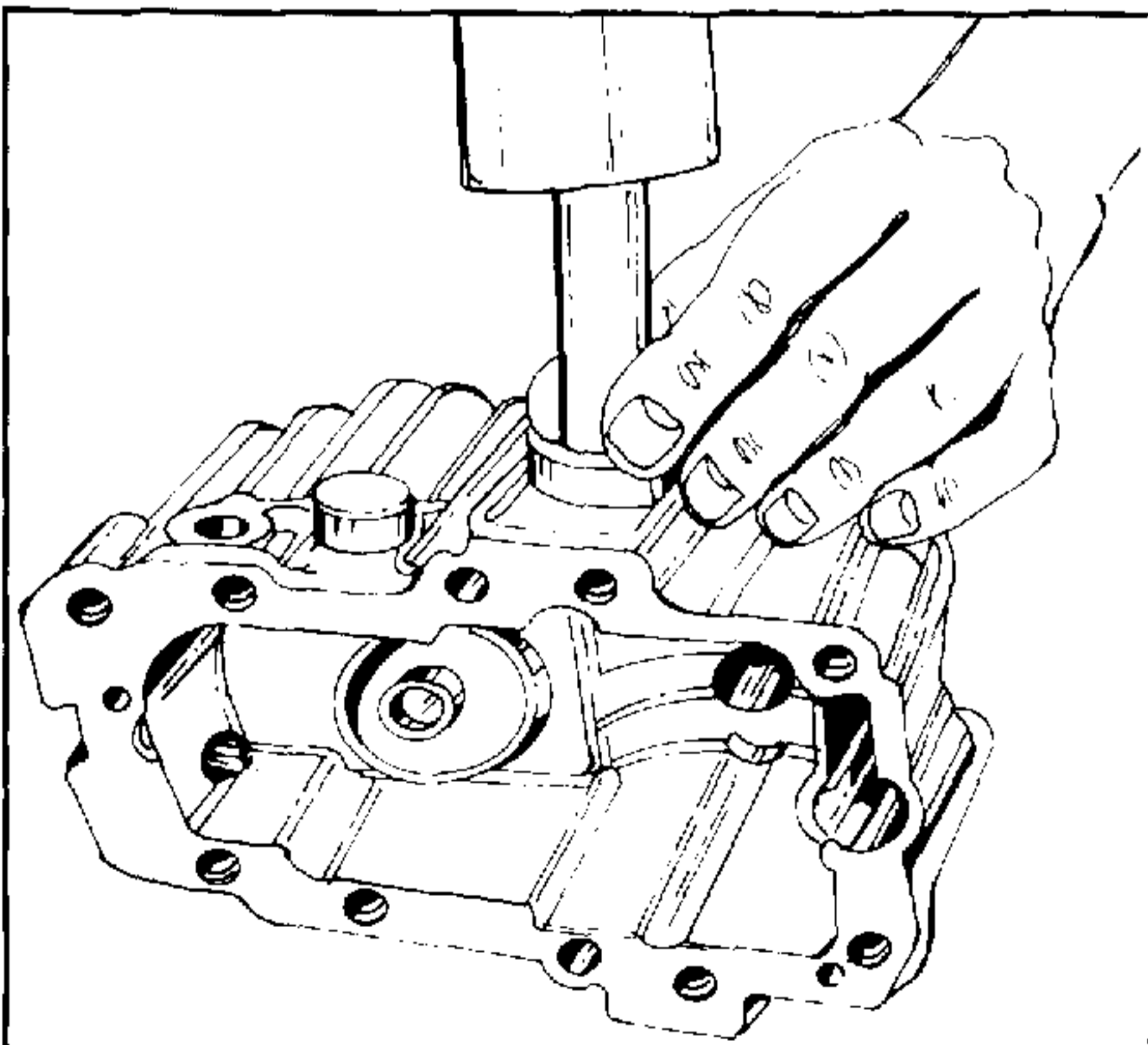

FIGURE 21.

5.7 Press out the journal bearing with soft
hammer.
TOOL: SOFT HAMMER
PRESS TOOL (PIPE etc.)

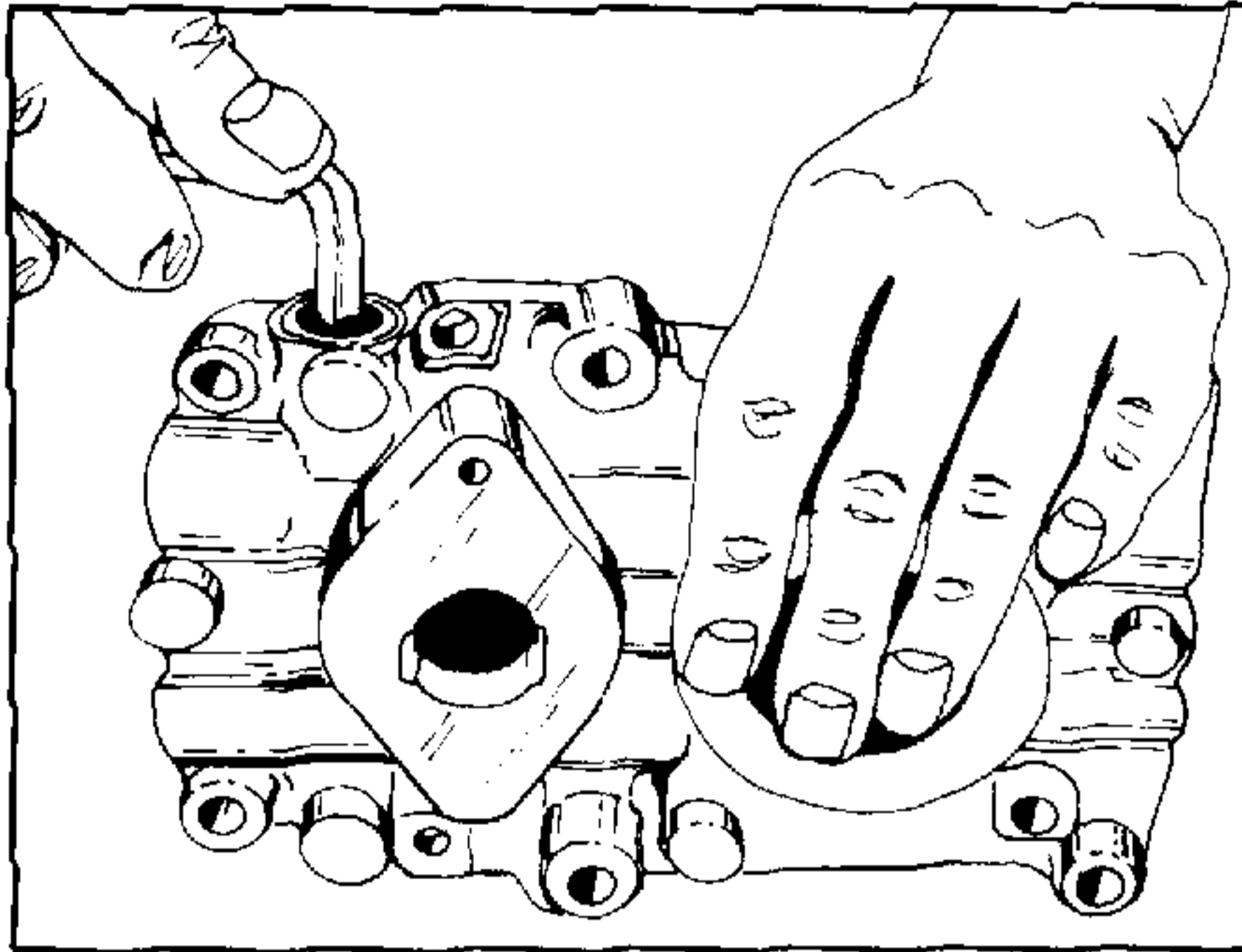

FIGURE 22.

6. Check valve

6.1 Remove the plug.

TOOL: HEX SOCKET SCREW KEY

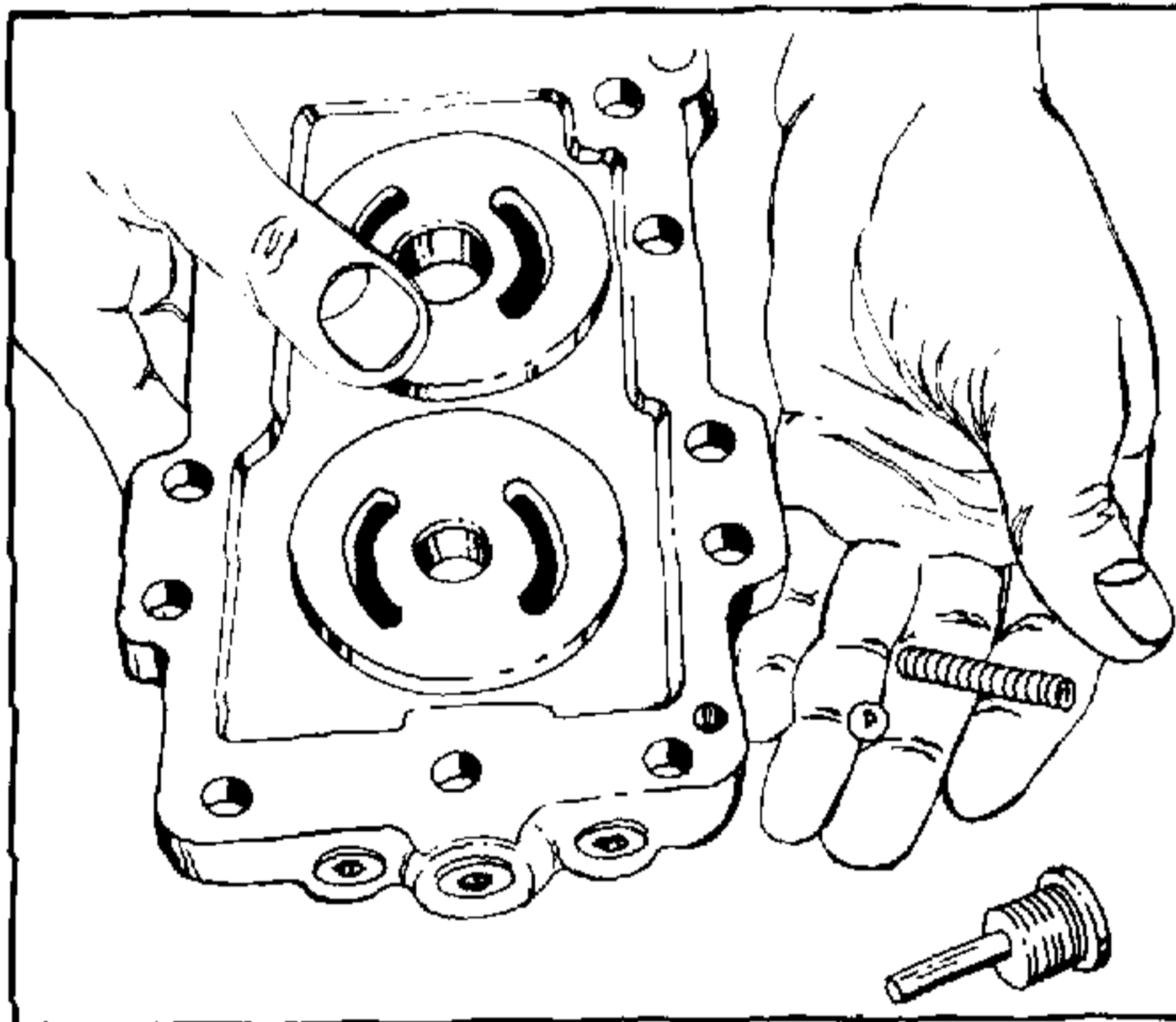

FIGURE 23.

6.2 Remove the spring and the check valve (ball) from bore in the center section.

In removing the check valve (ball), care should be taken that it doesn't fall into the closed loop passage.

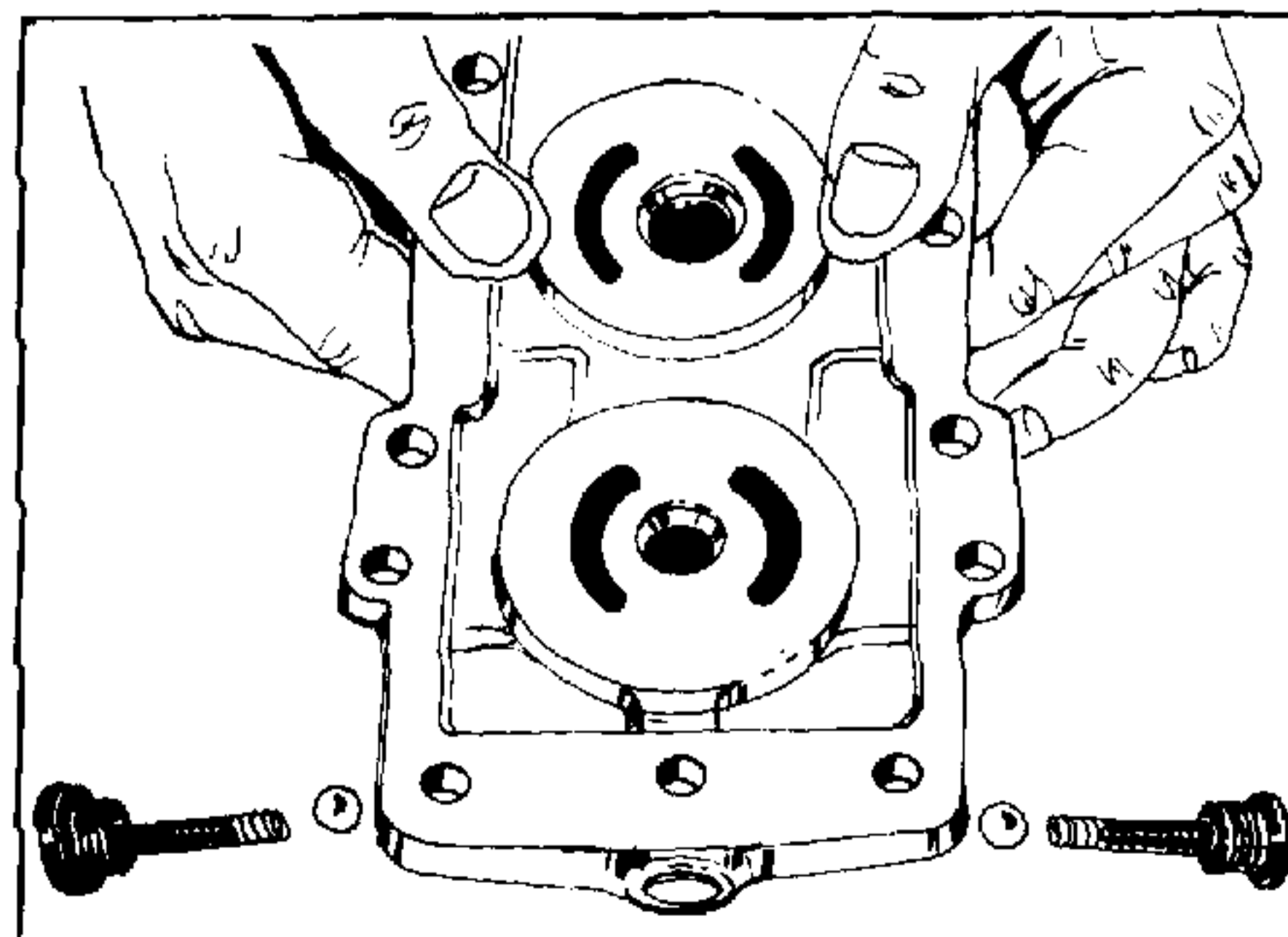

FIGURE 24.

6.3 Remove both sides.

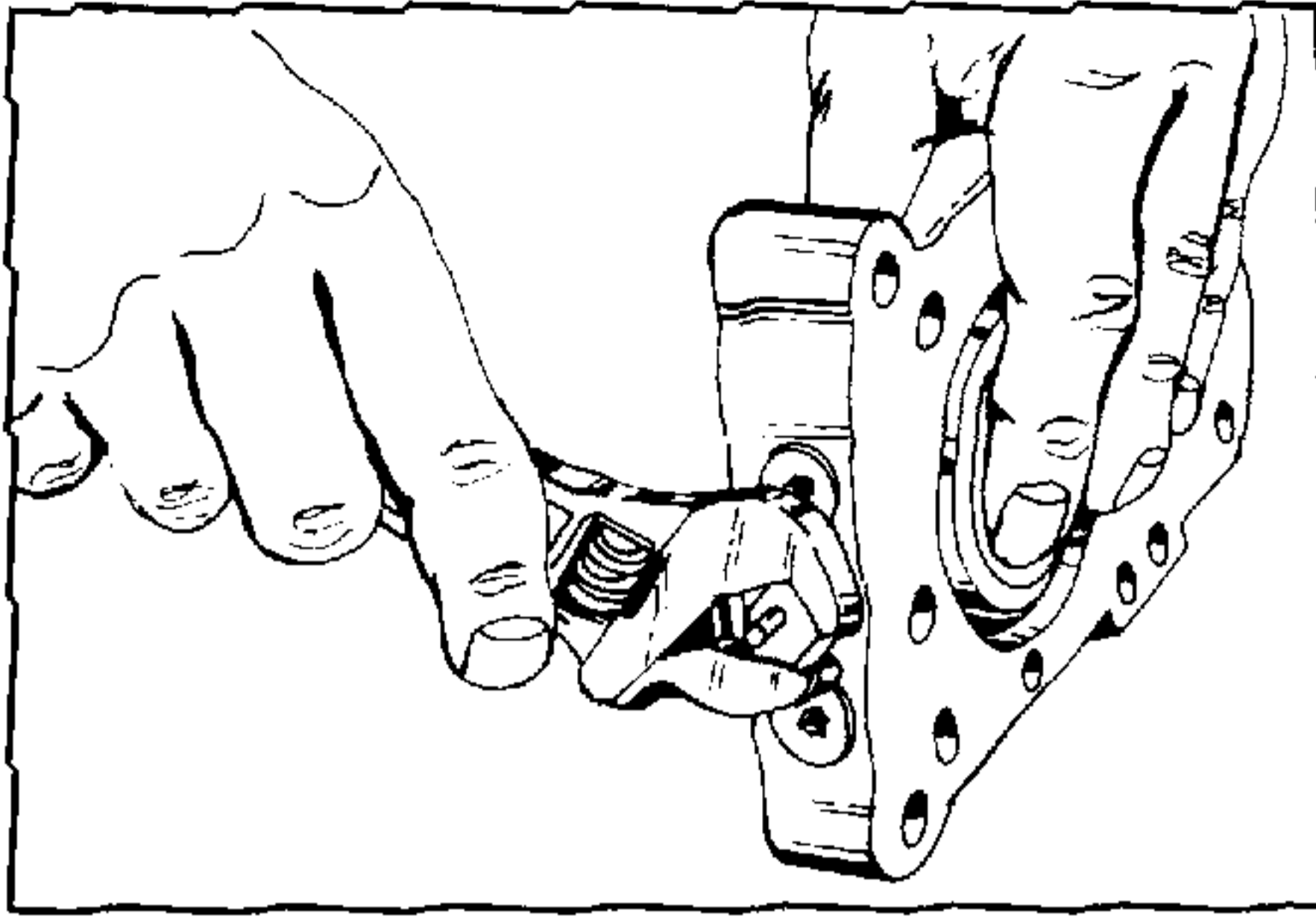

FIGURE 25.

7. By-pass valve.

7.1 Remove the plug and the by-pass spool.

TOOL: SPANNER

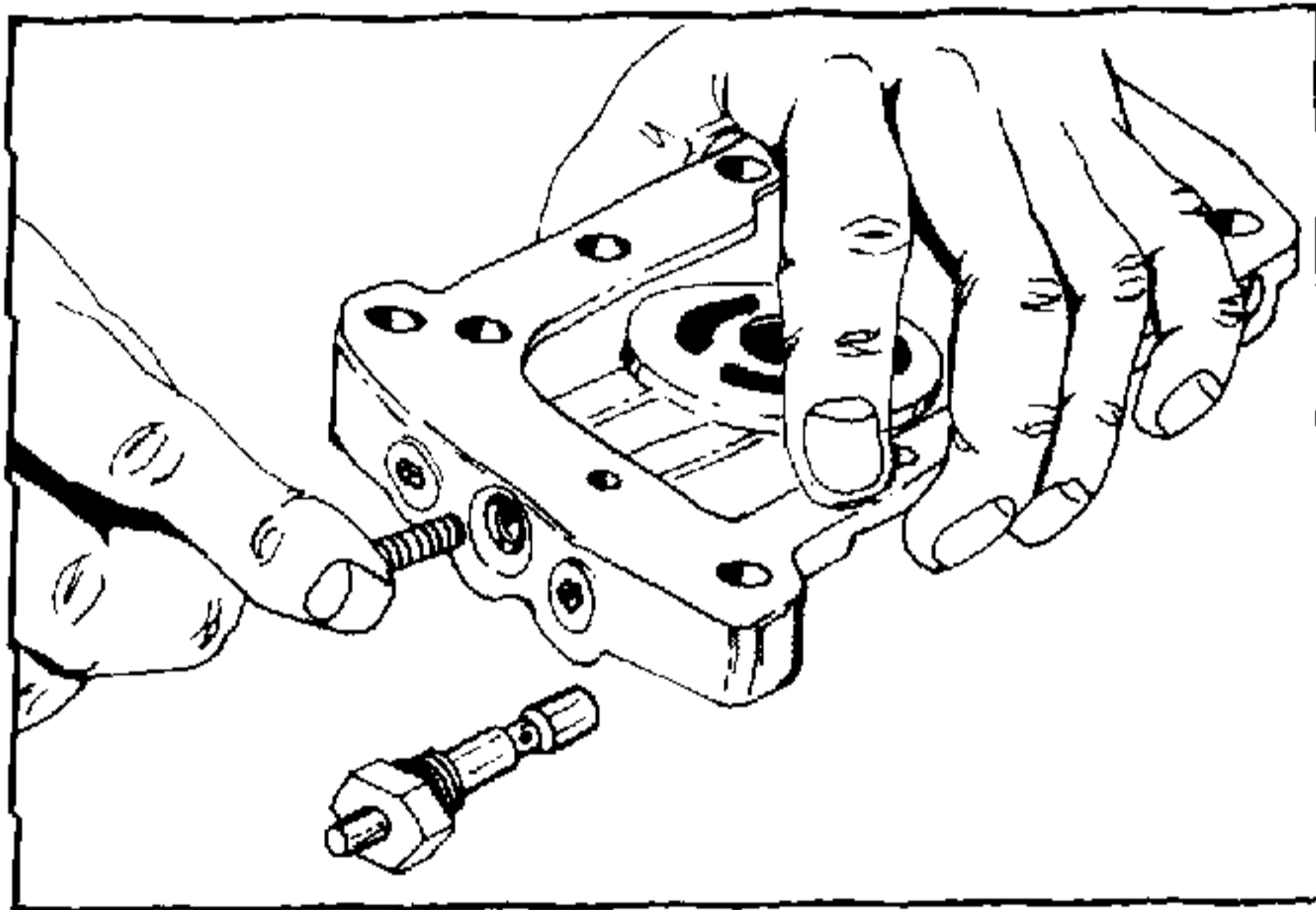

FIGURE 26.

7.2 Remove the spring from the center section.

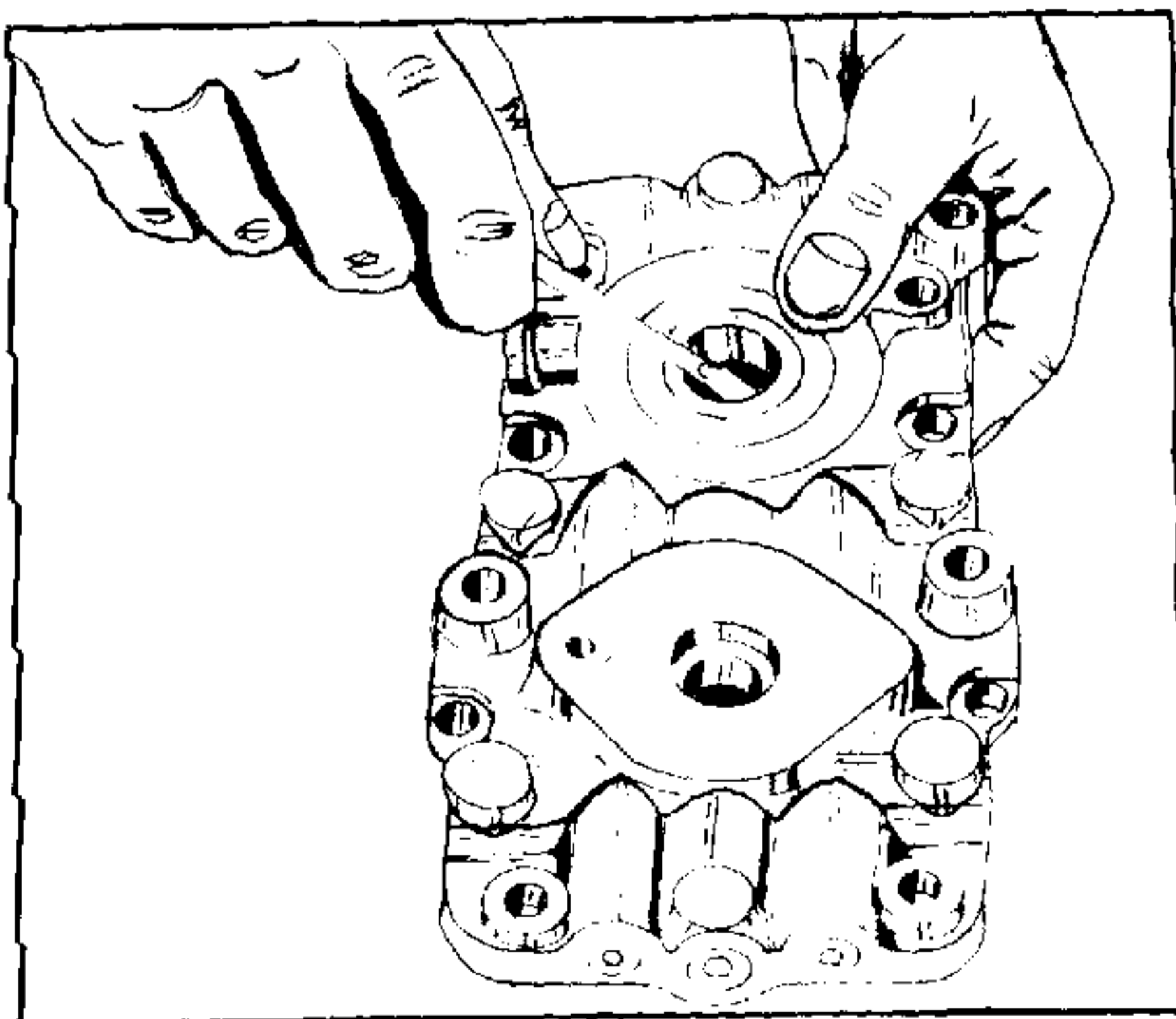

FIGURE 27.

8. Oil seal (center section).

Pry the oil seal out with screwdriver.

Take care not to damage the center section.

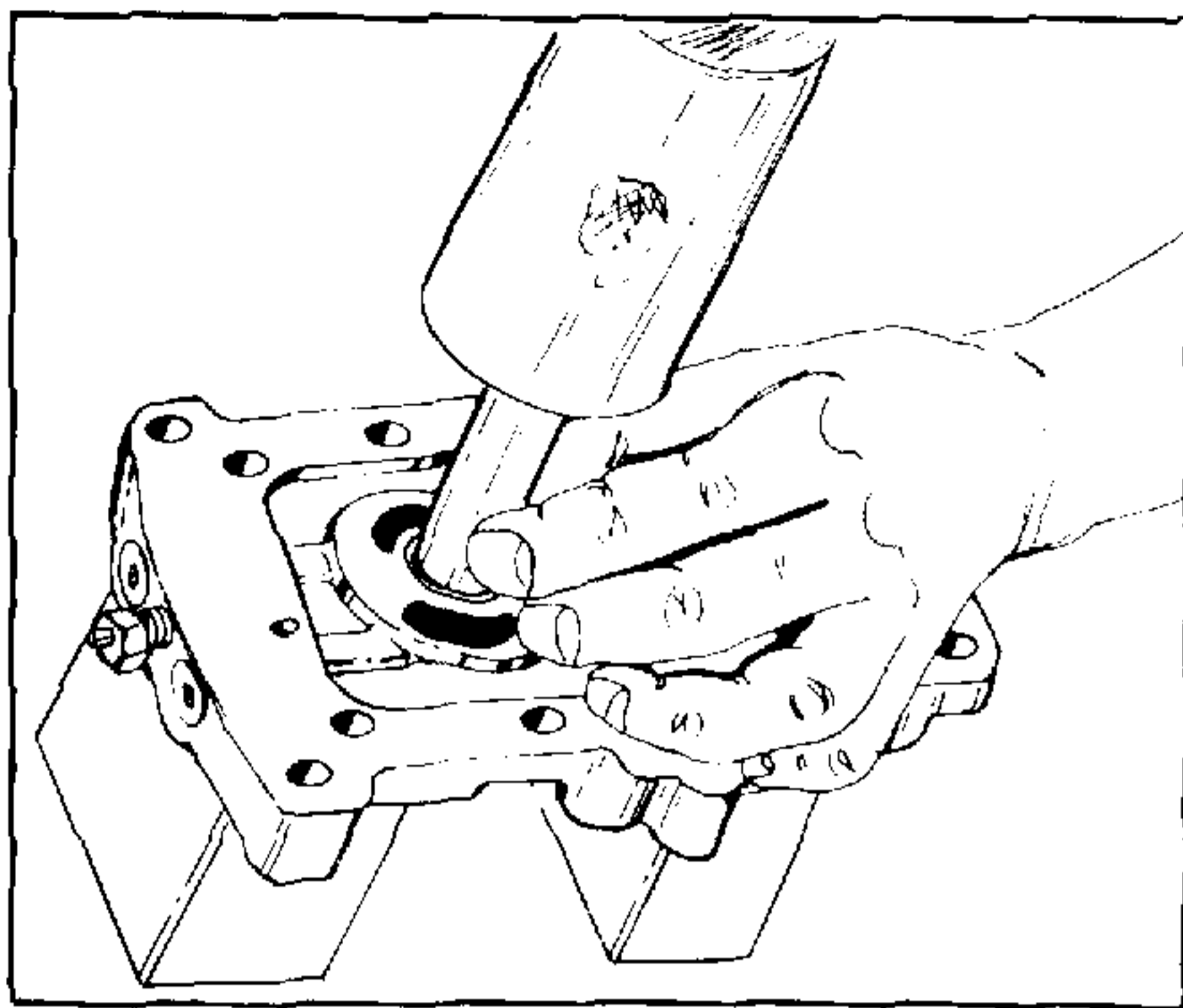

FIGURE 28.

9. Press out the needle bearing.
TOOL: HAMMER, PRESS TOOL (PIPE etc.)

3. ASSEMBLY

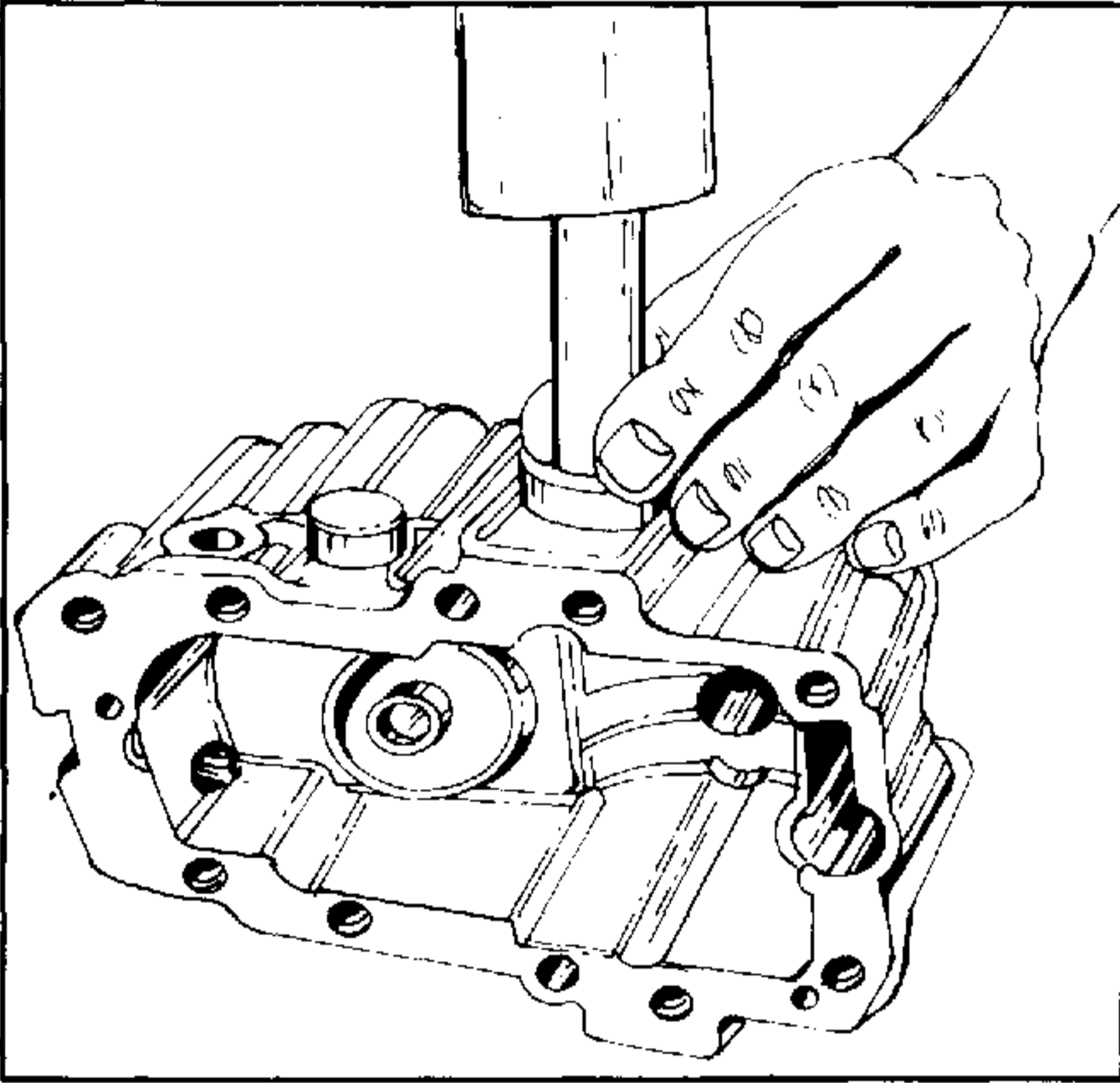

FIGURE 29.

1. Trunnion arm

1.1 Press the journal bearing into the housing.

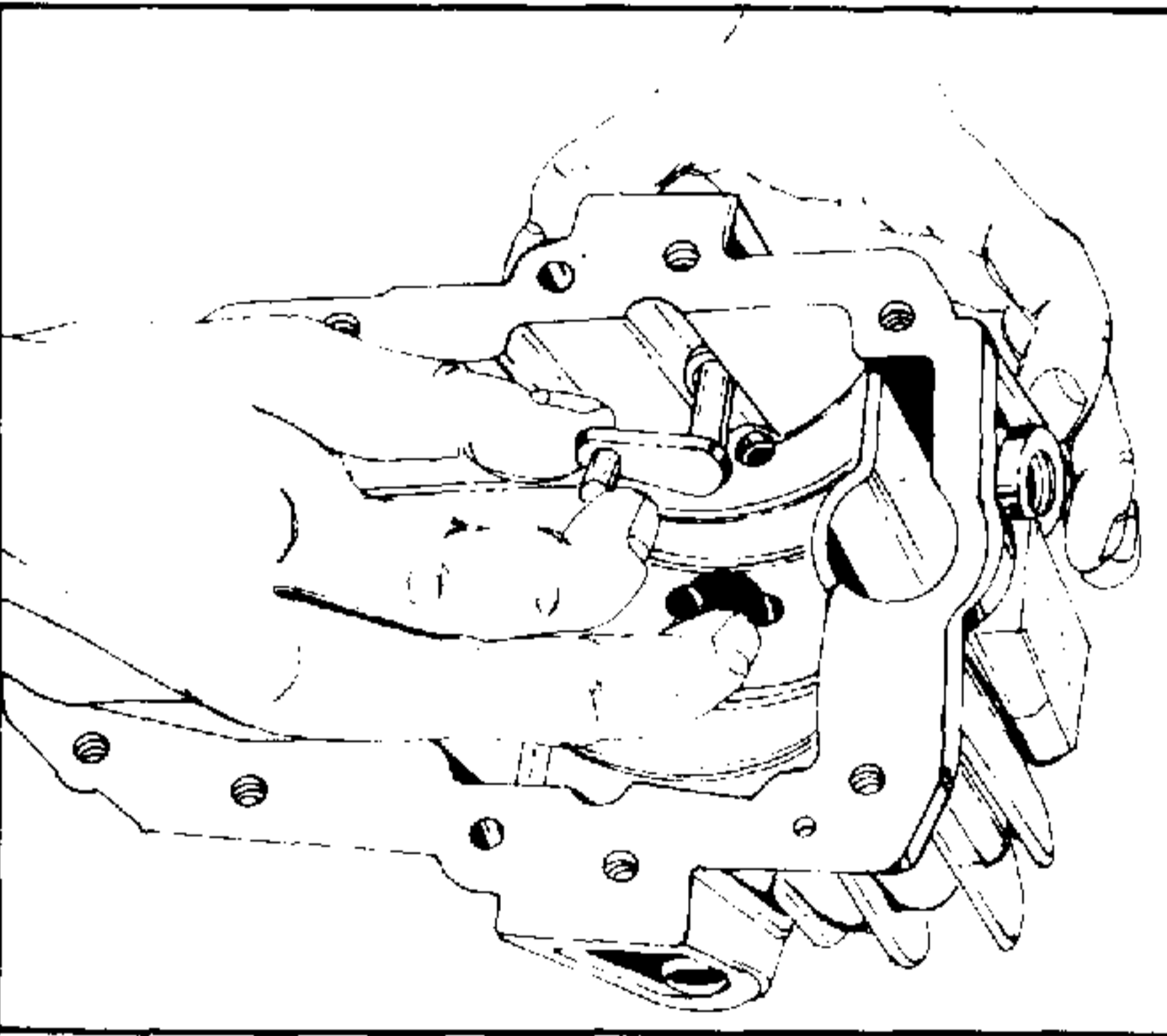

FIGURE 30.

1.2 Install the trunnion arm.

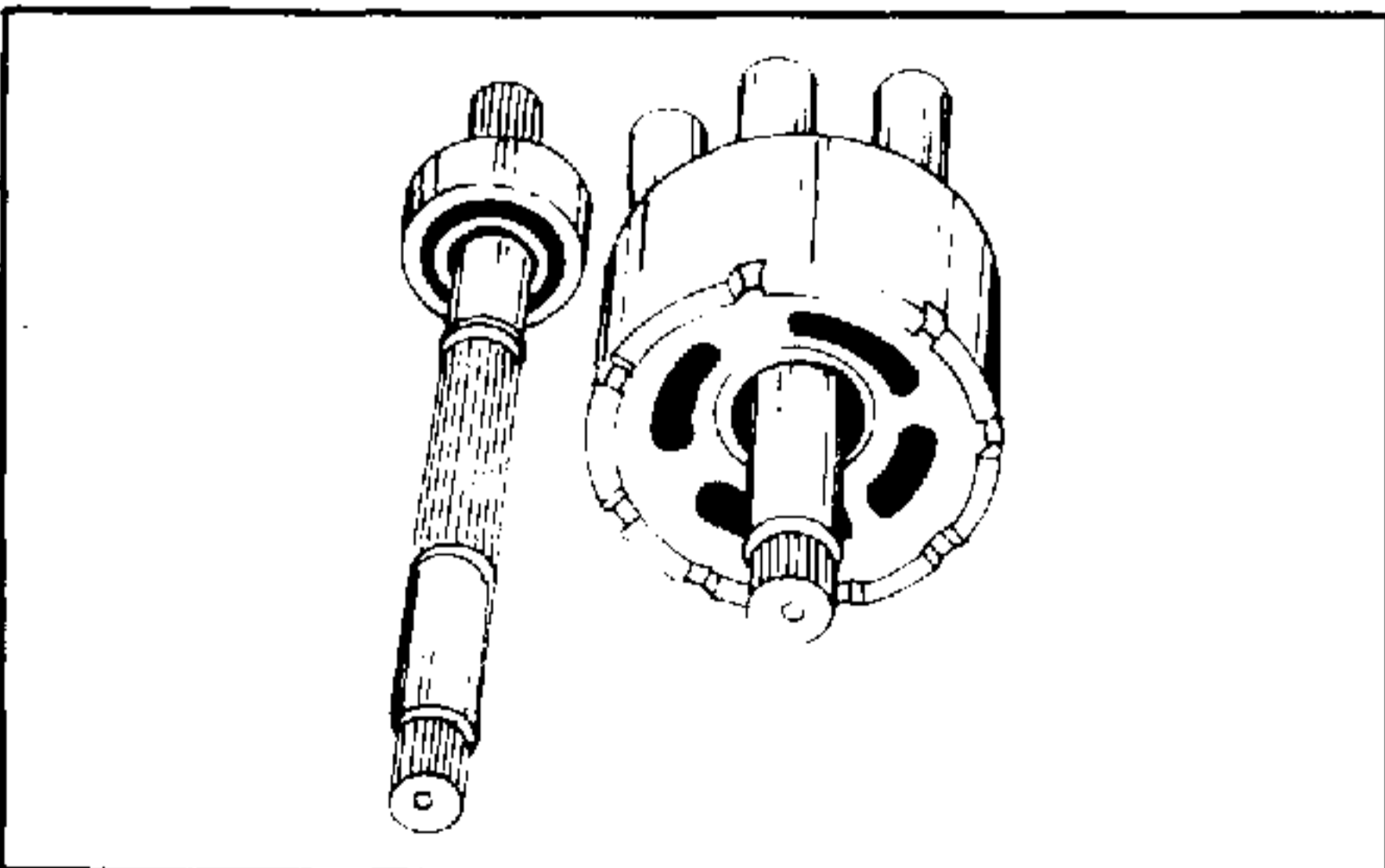

FIGURE 31.

2. Pump shaft

2.1 Check the seal surface, bearing surface, spline and the bearing for damage (pump, motor).

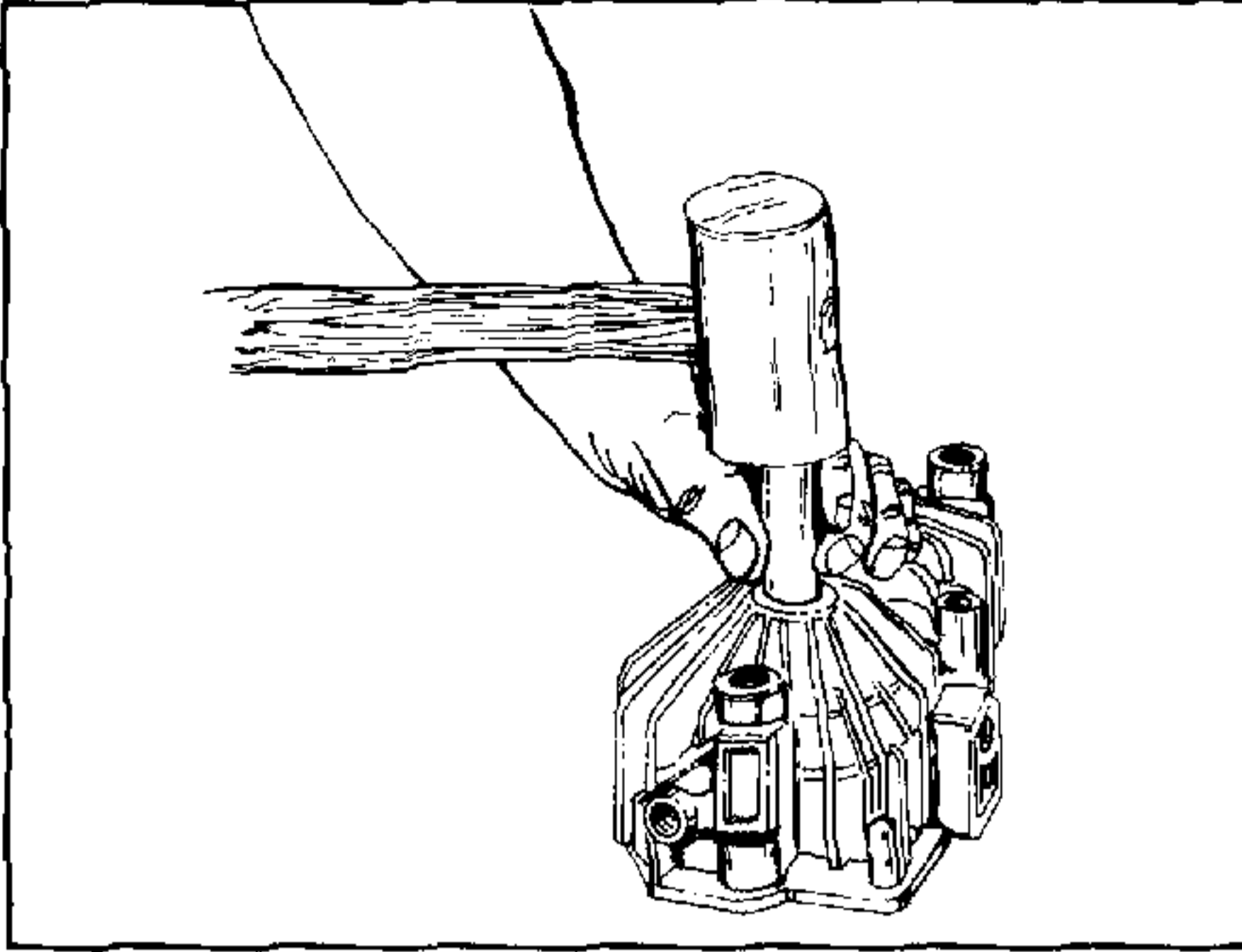

FIGURE 32.

2.2 Press the shaft into the housing.
TOOL: HAMMER, PRESS TOOL (PIPE etc.)

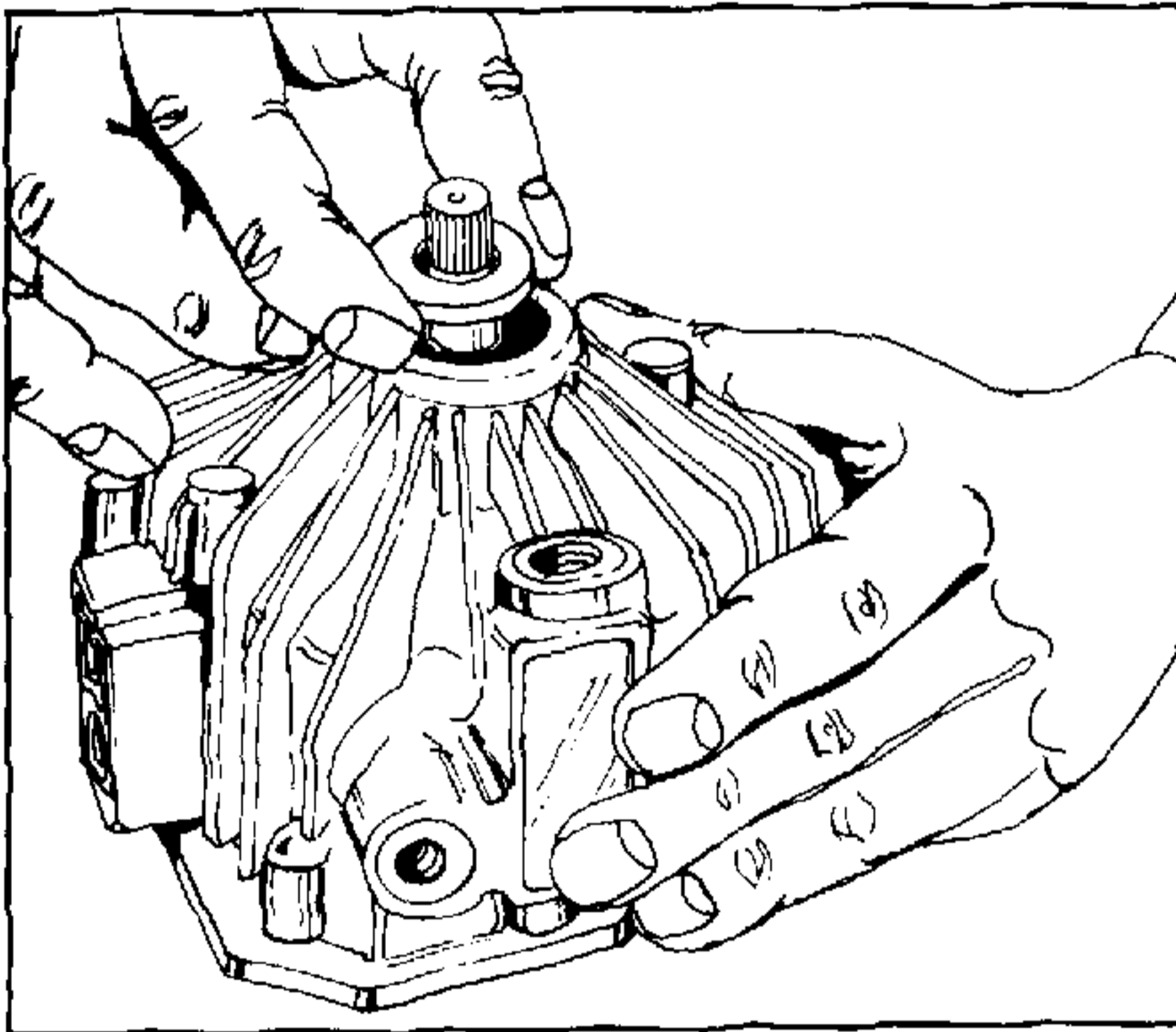

FIGURE 33.

2.3 Place the spacer on the bearing.

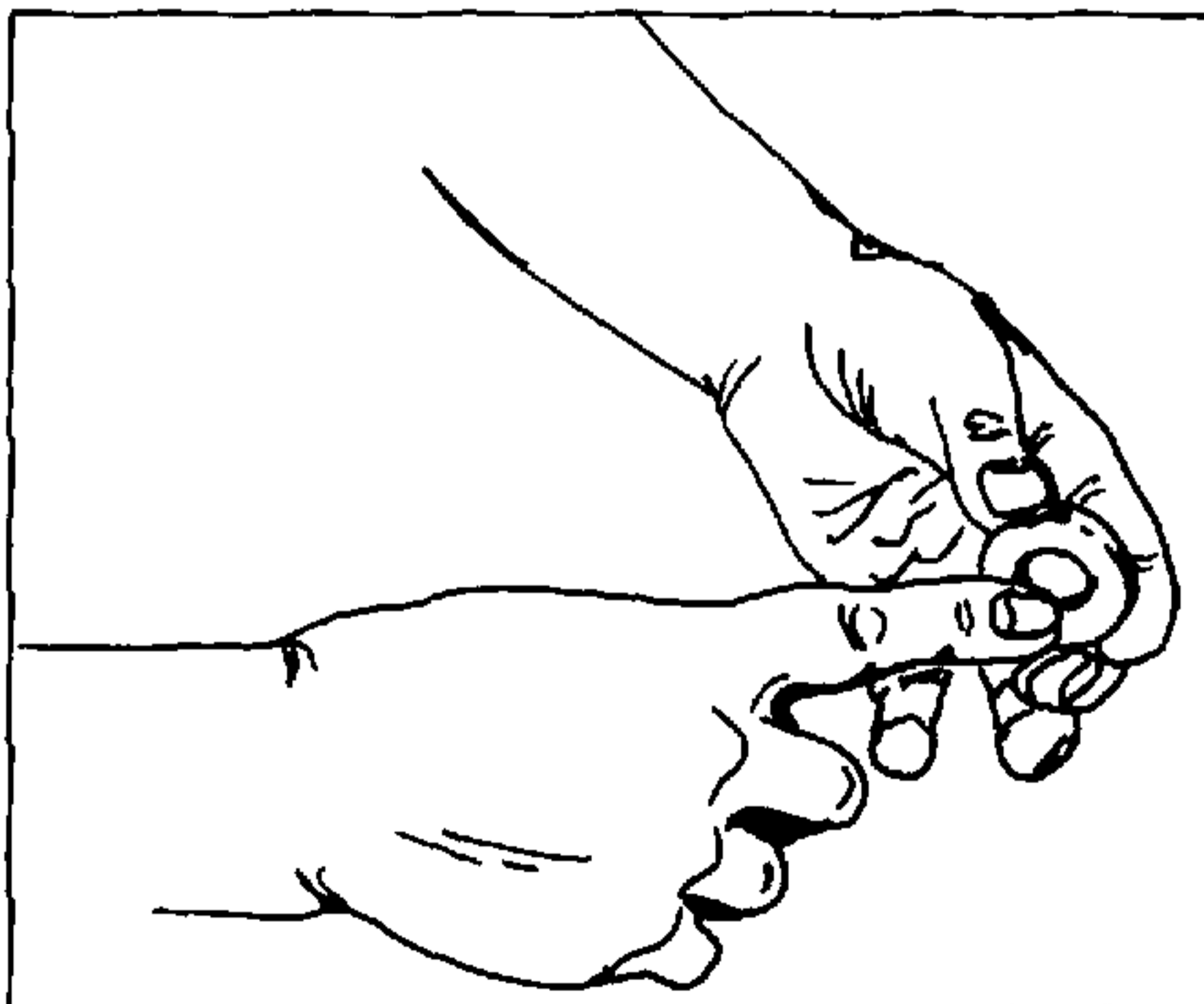
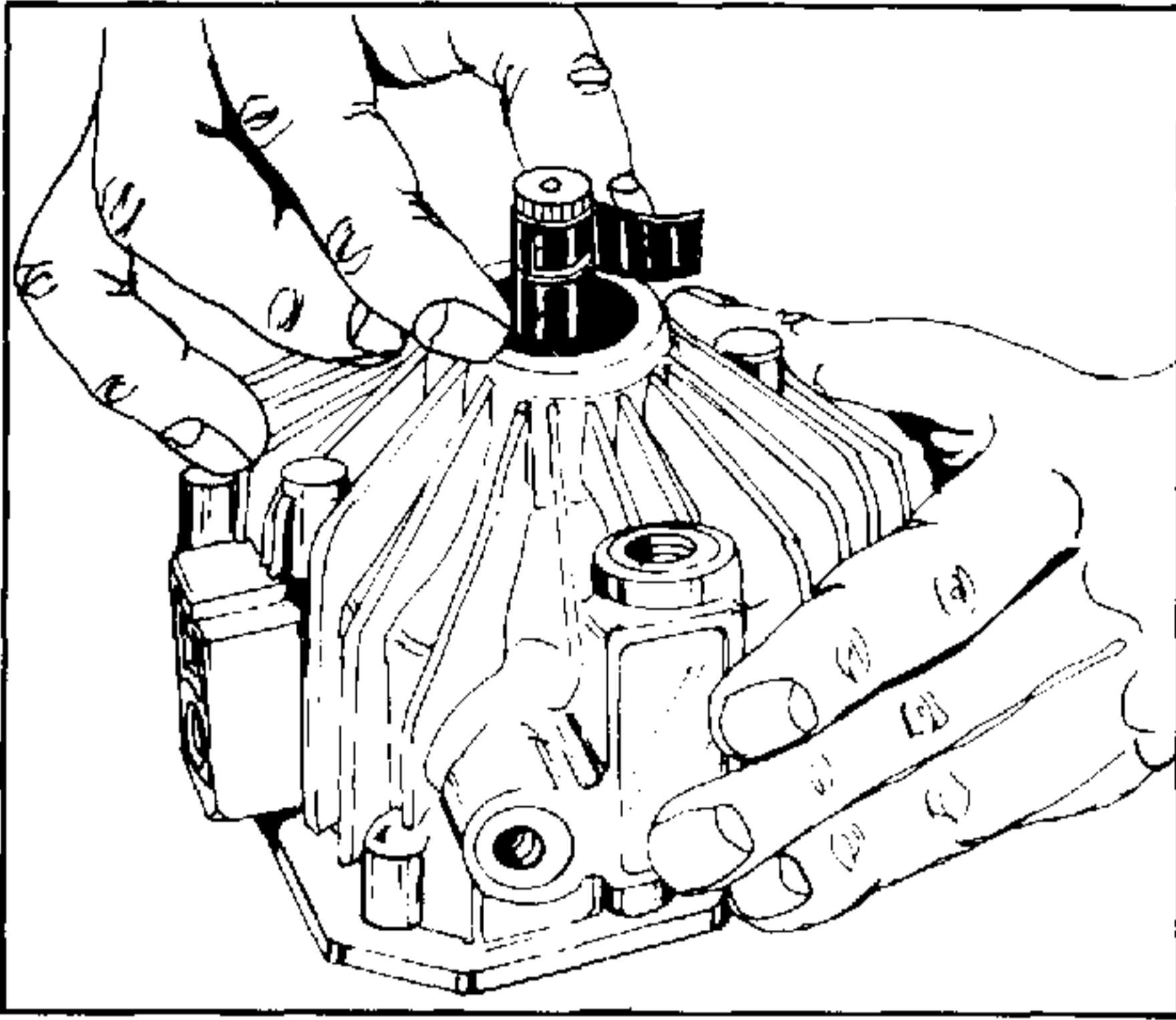

FIGURE 34.

2.4 Coat new oil seal lip with grease.



2.5 Cover the pump shaft with thin tape to protect oil seal lip.

FIGURE 35.

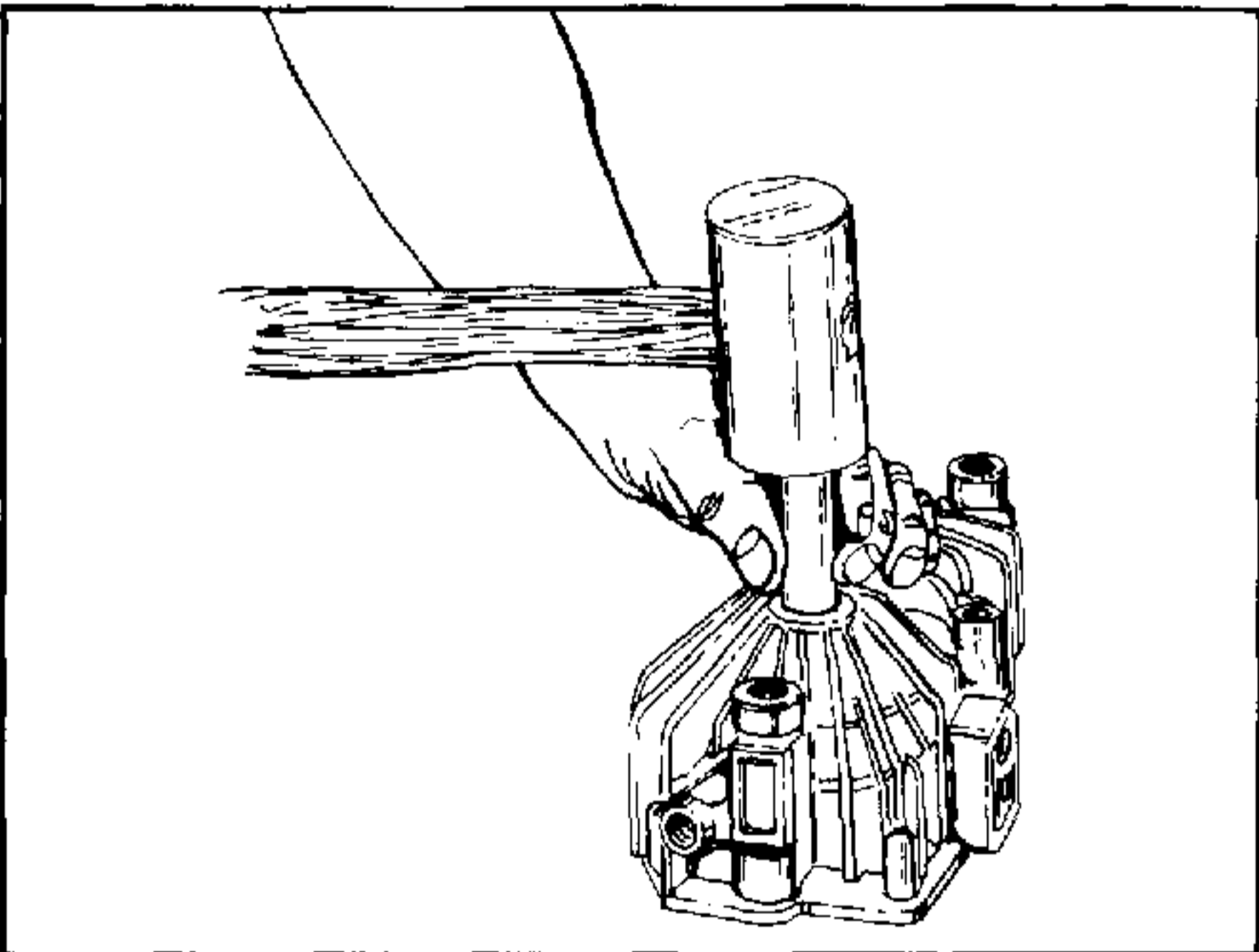

2.6 Press the seal into the housing bore.
TOOL: HAMMER, PRESS TOOL (PIPE etc.)

FIGURE 36.

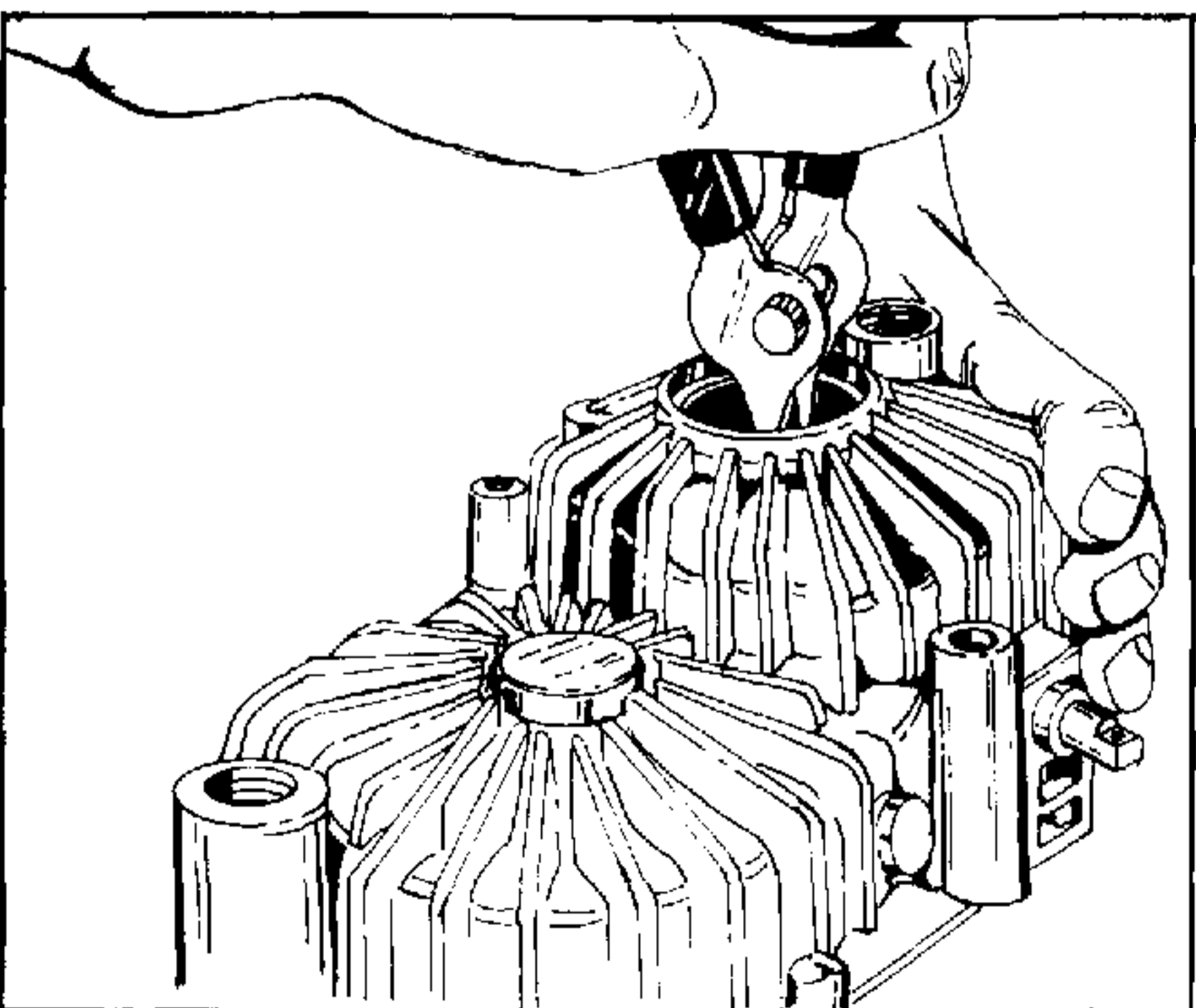

2.7 Install the retaining ring in groove in the housing.
RETAINING RING: FOR HOLE 35
TOOL: PLIER

FIGURE 37.

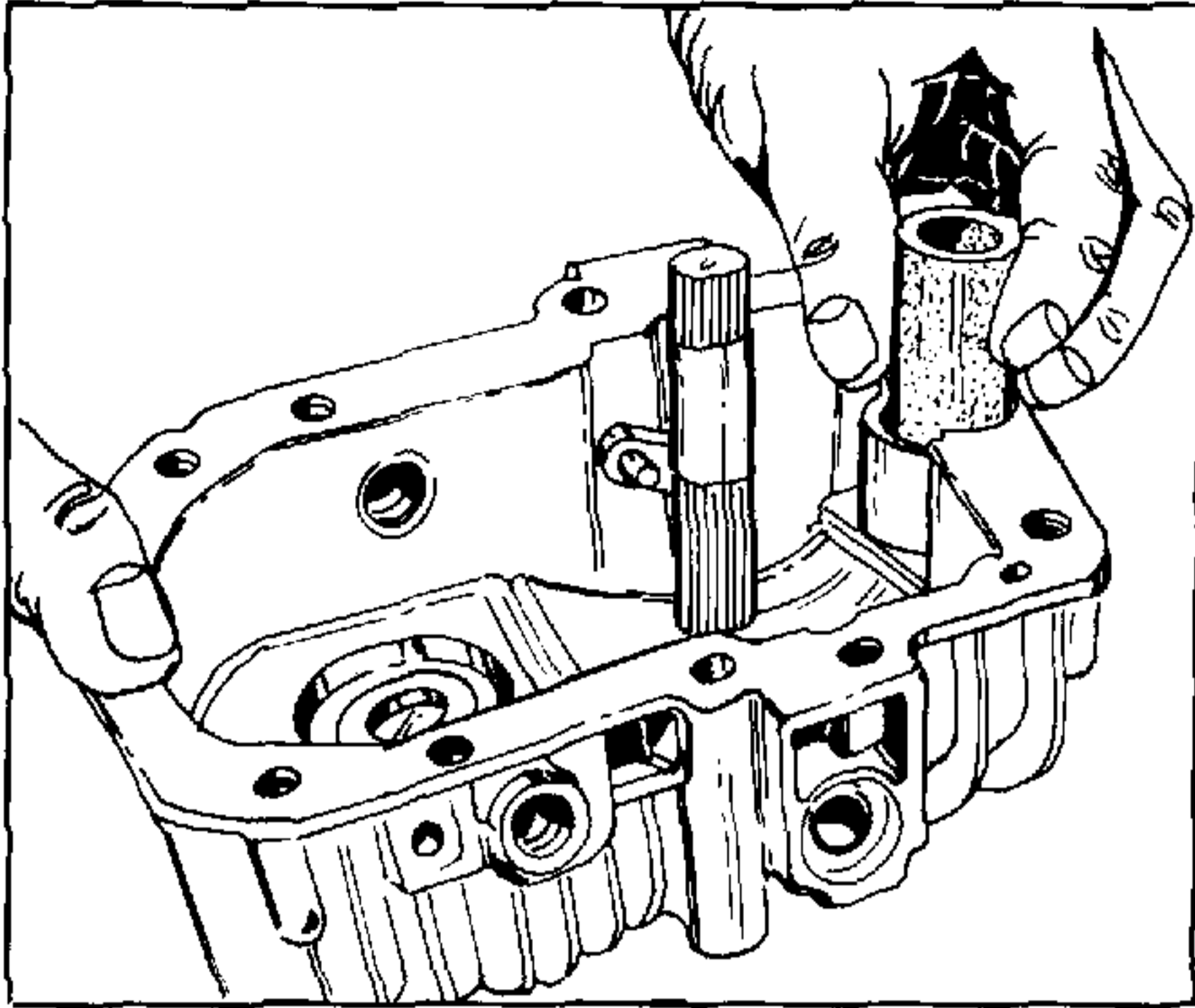

FIGURE 38.

3. Swashplate, Filter

3.1 Check the filter.

Place the spring, washer and the filter.

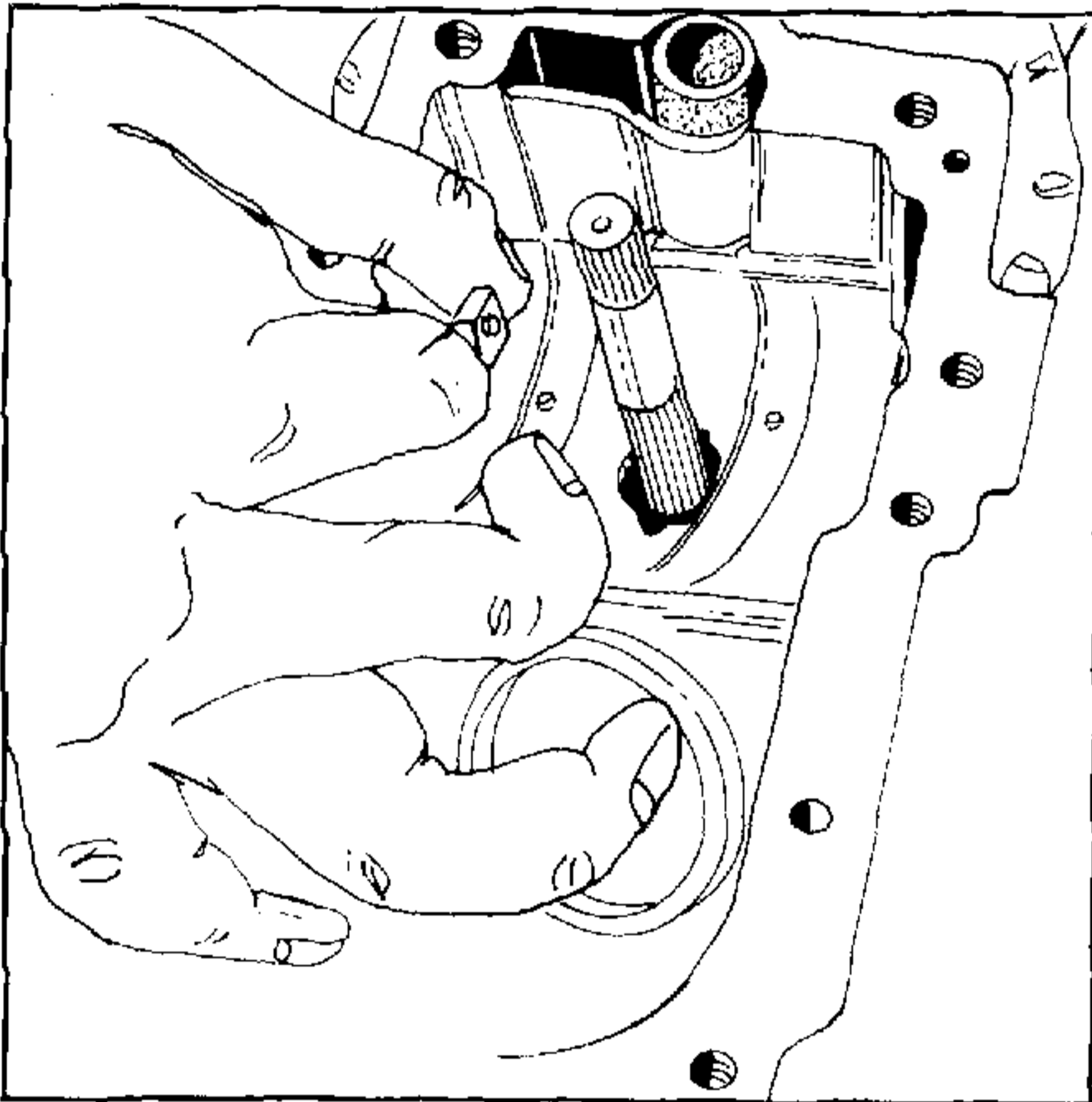

FIGURE 39.

3.2 Slide the slot guide on the trunnion arm.

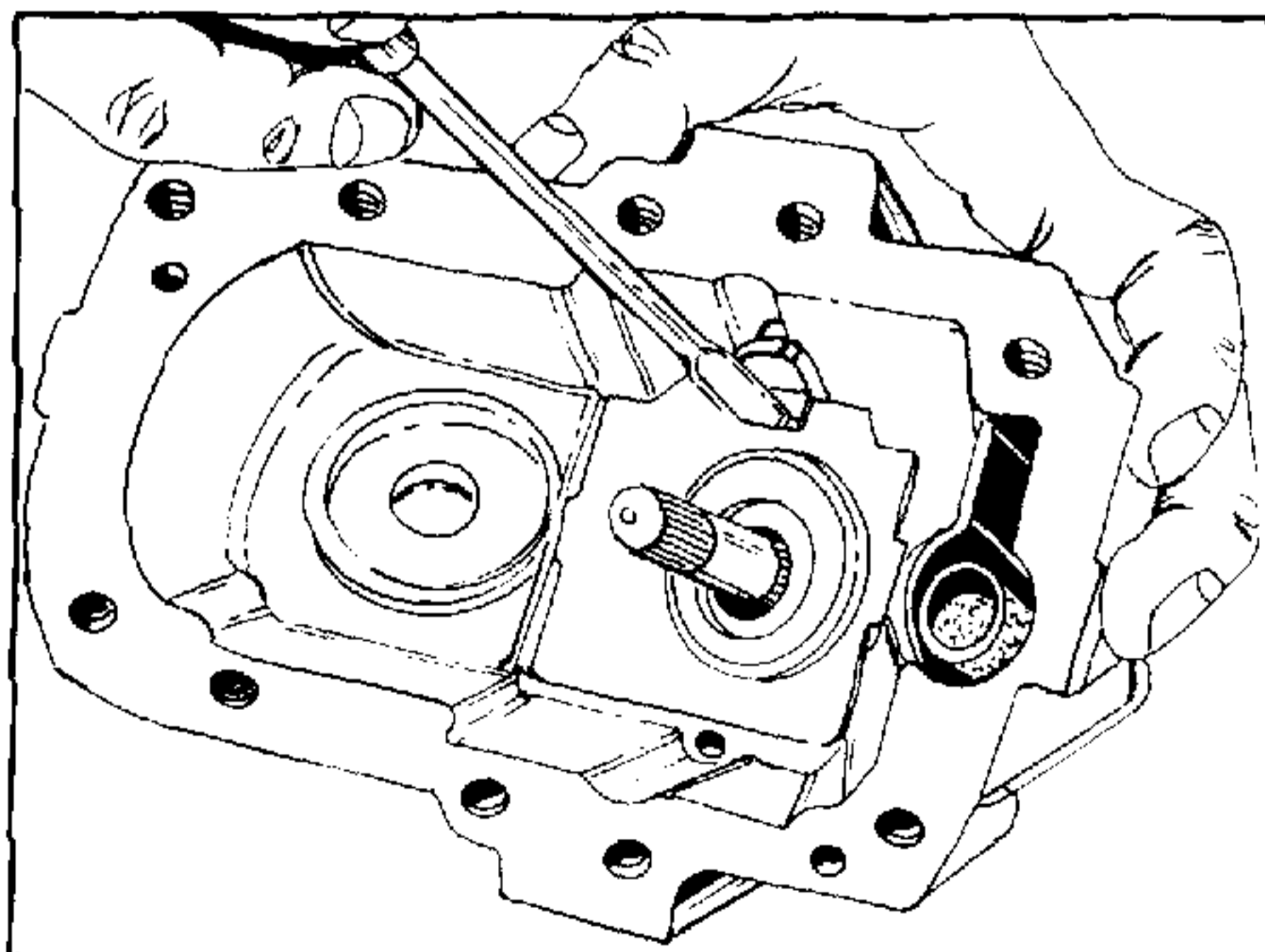

FIGURE 40.

3.3 Place the swashplate into the housing, keeping the slot guide from moving with driver.

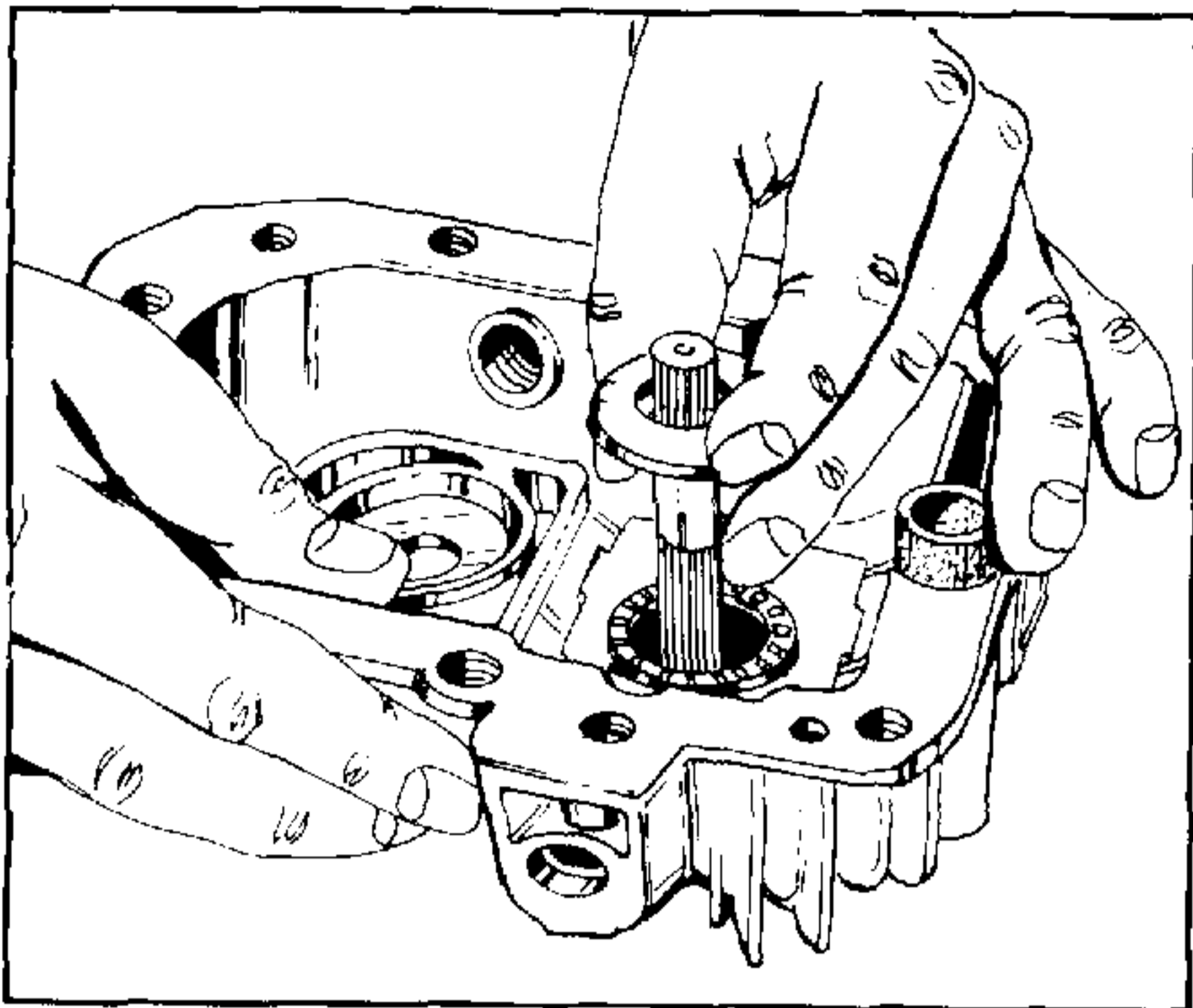
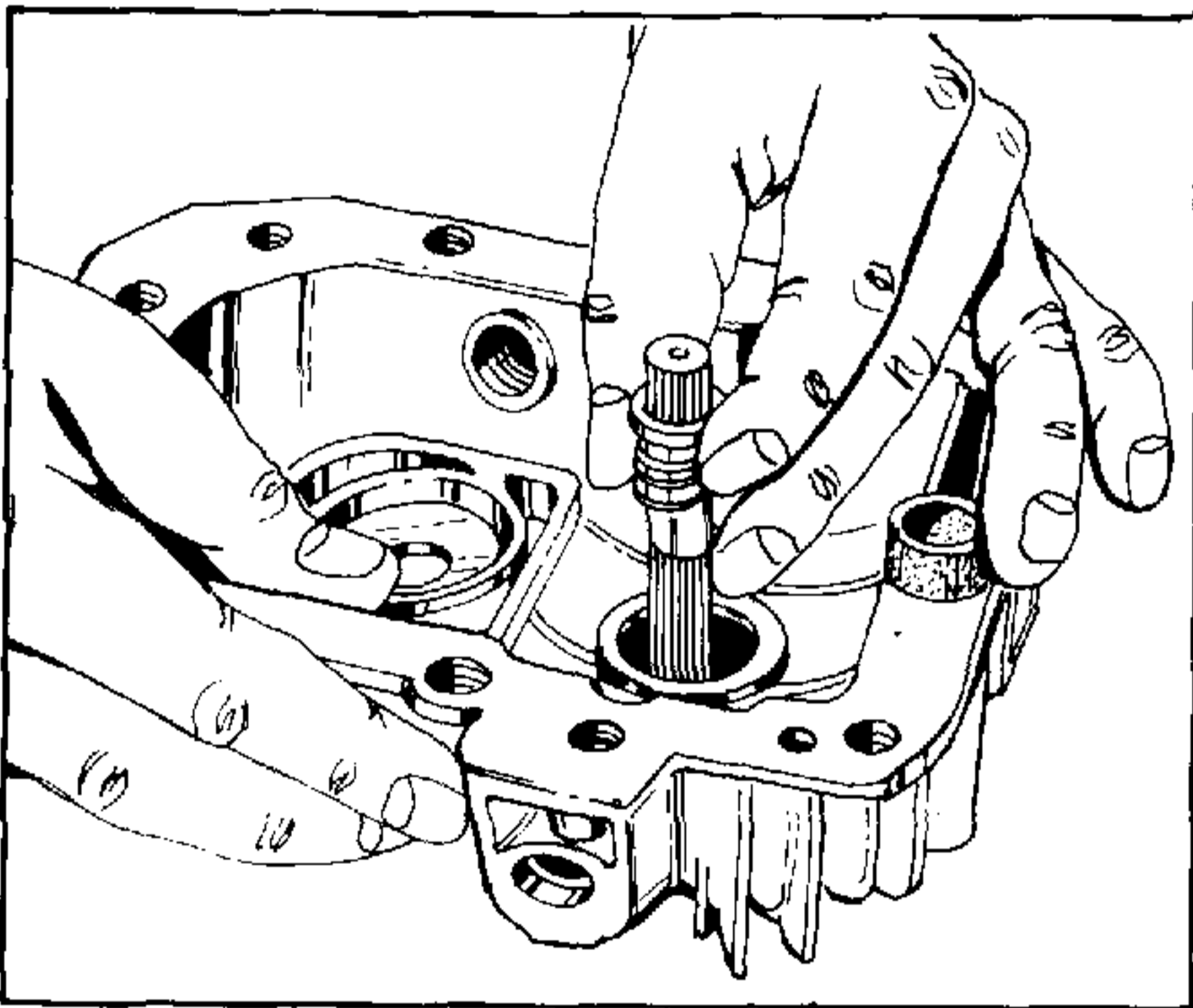

FIGURE 41.

4. Thrust plate, Roller, Bearing

4.1 Place the thrust plate and the thrust roller into the swashplate.



4.2 Place the washer and the spring on the swashplate.

FIGURE 42.

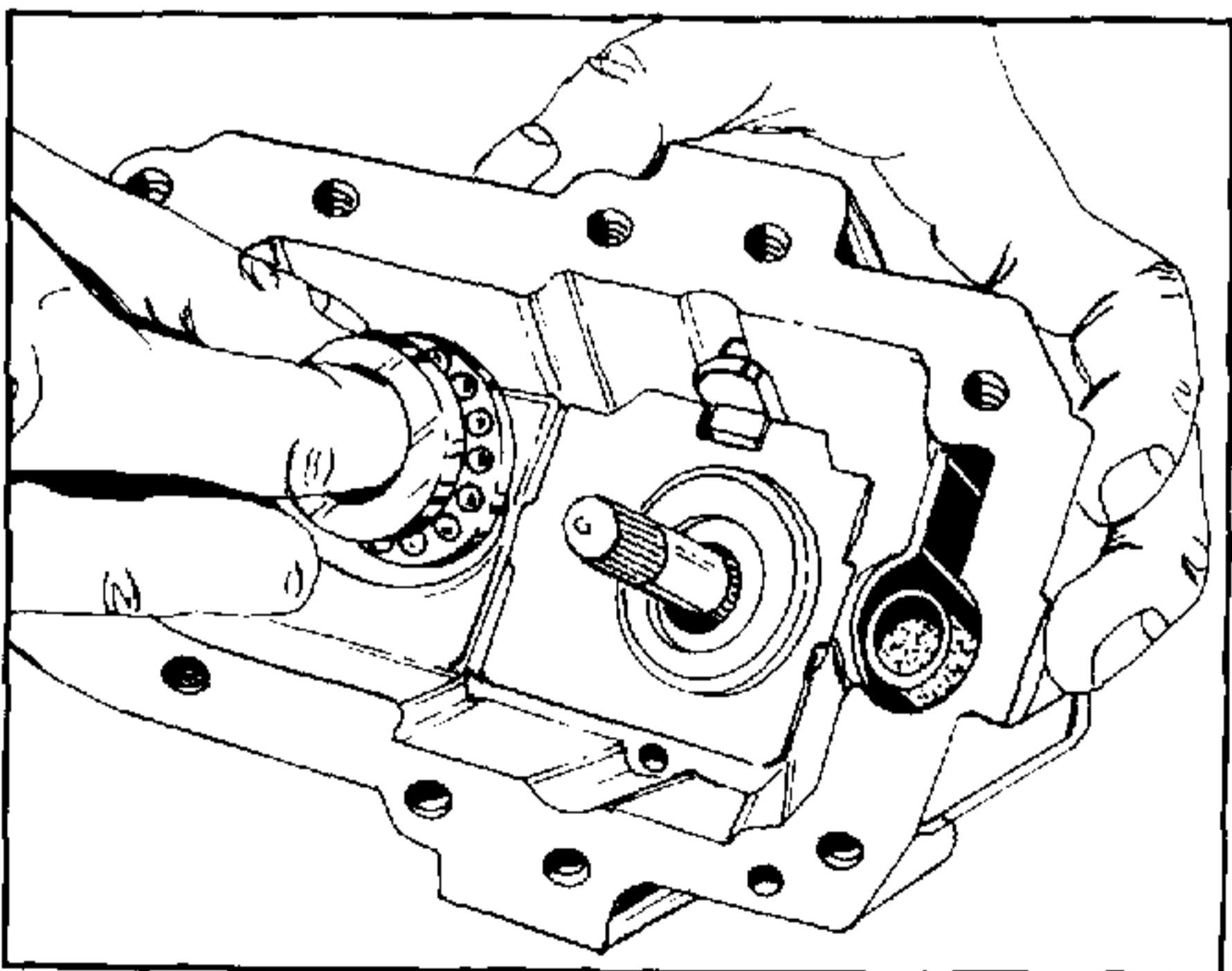

4.3 Place the thrust ball bearing (motor).

FIGURE 43.

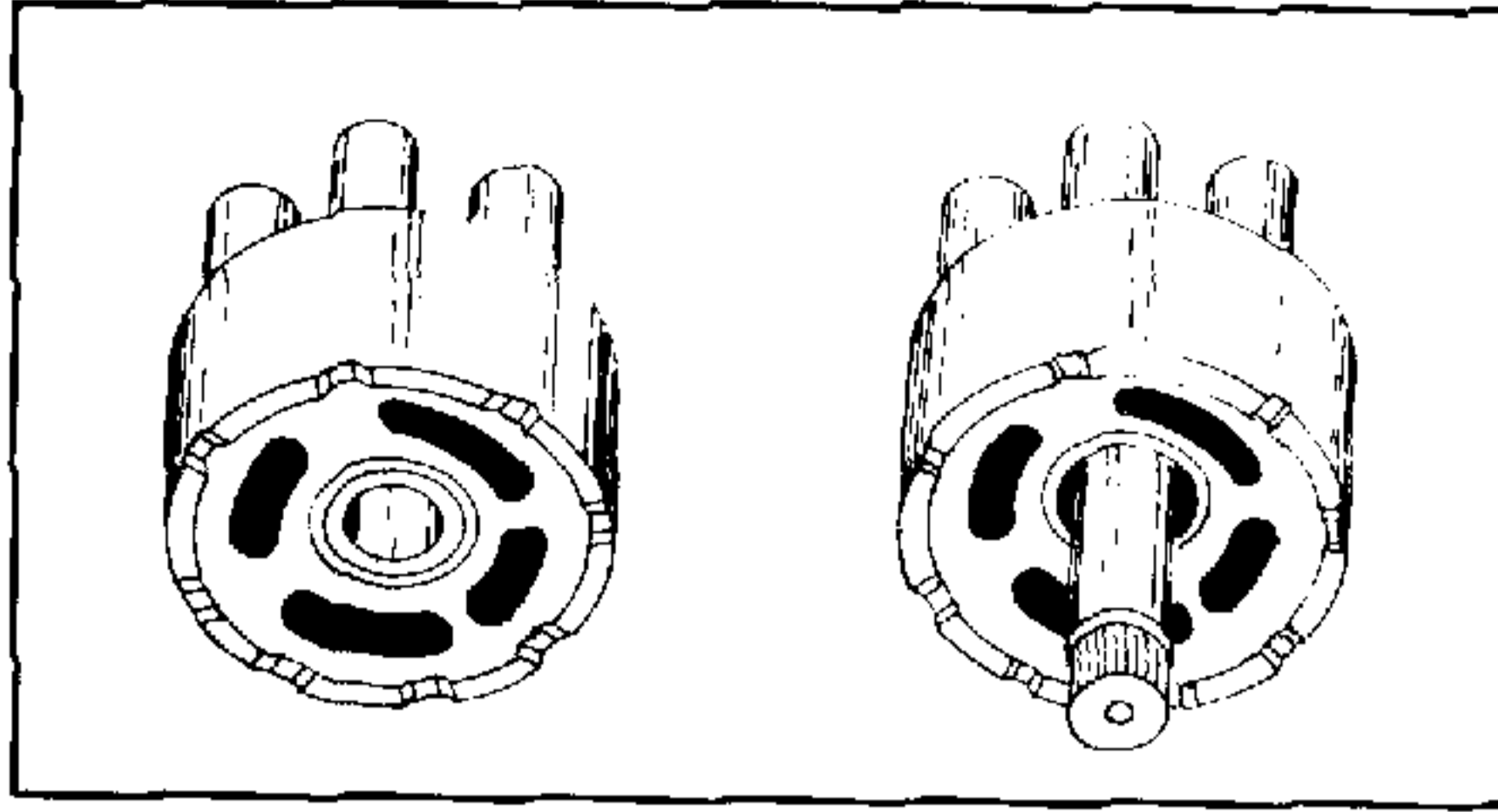

FIGURE 44.

5. Cylinder block kit

5.1 Check cylinder blocks and pistons for scratches and wear.

When the surface of cylinder block is worn down more than 0.01 mm, exchange the cylinder block kit for new one (pump, motor).

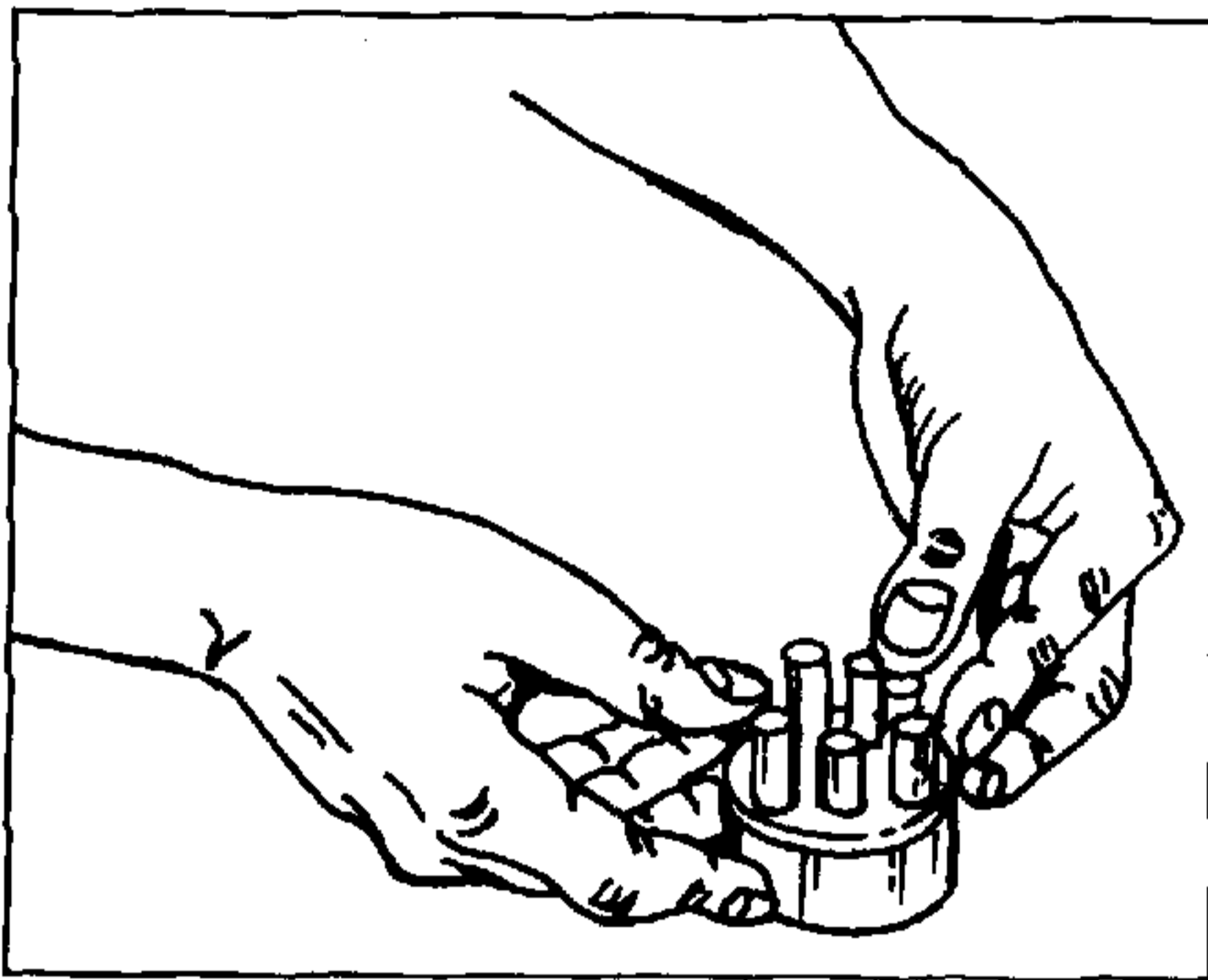

FIGURE 45.

5.2 Check to be sure pistons are free in bores (pump, motor).

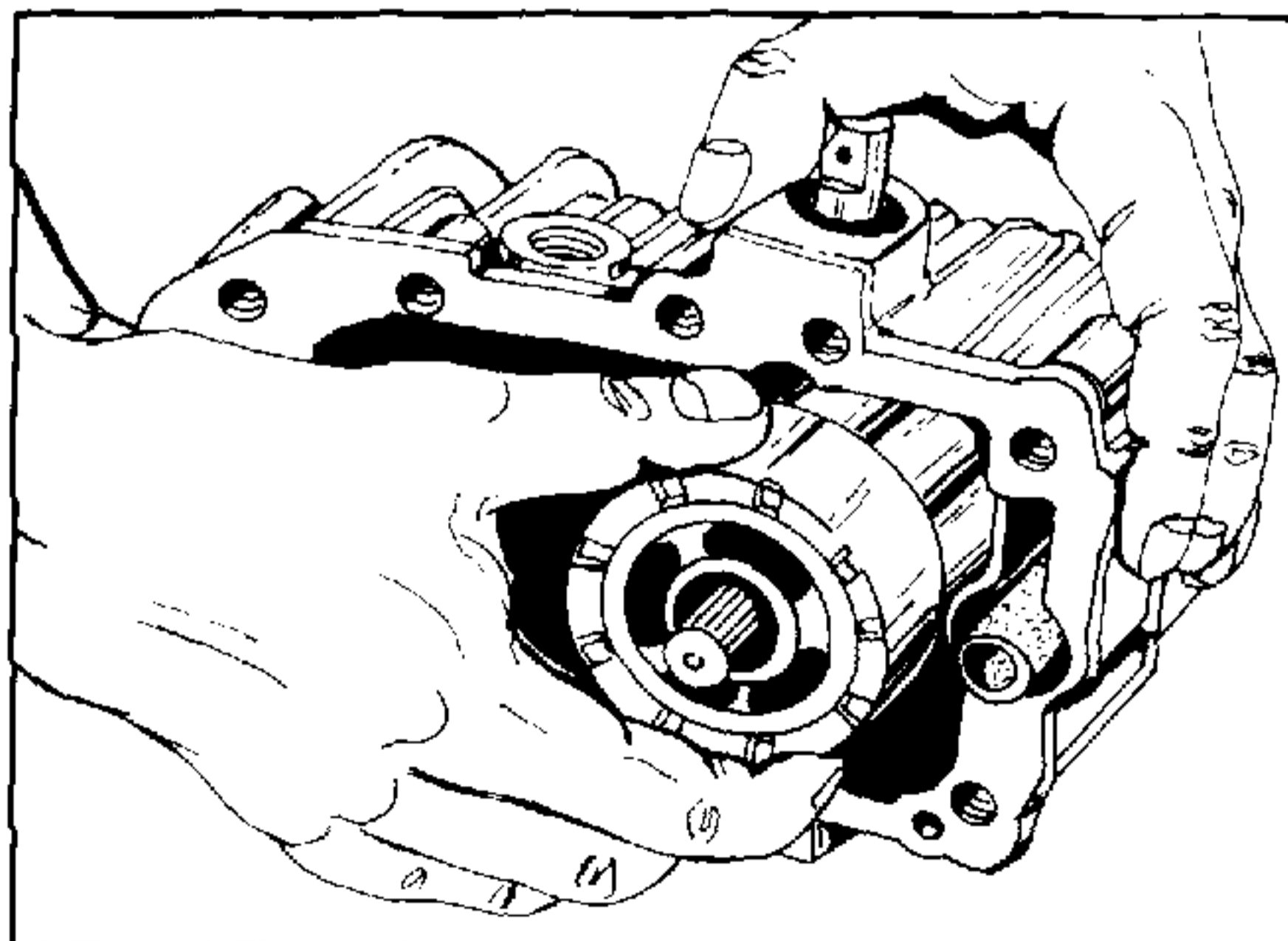

FIGURE 46.

5.3 Lay the housing on its side and slide cylinder block kits into housing (pump, motor).

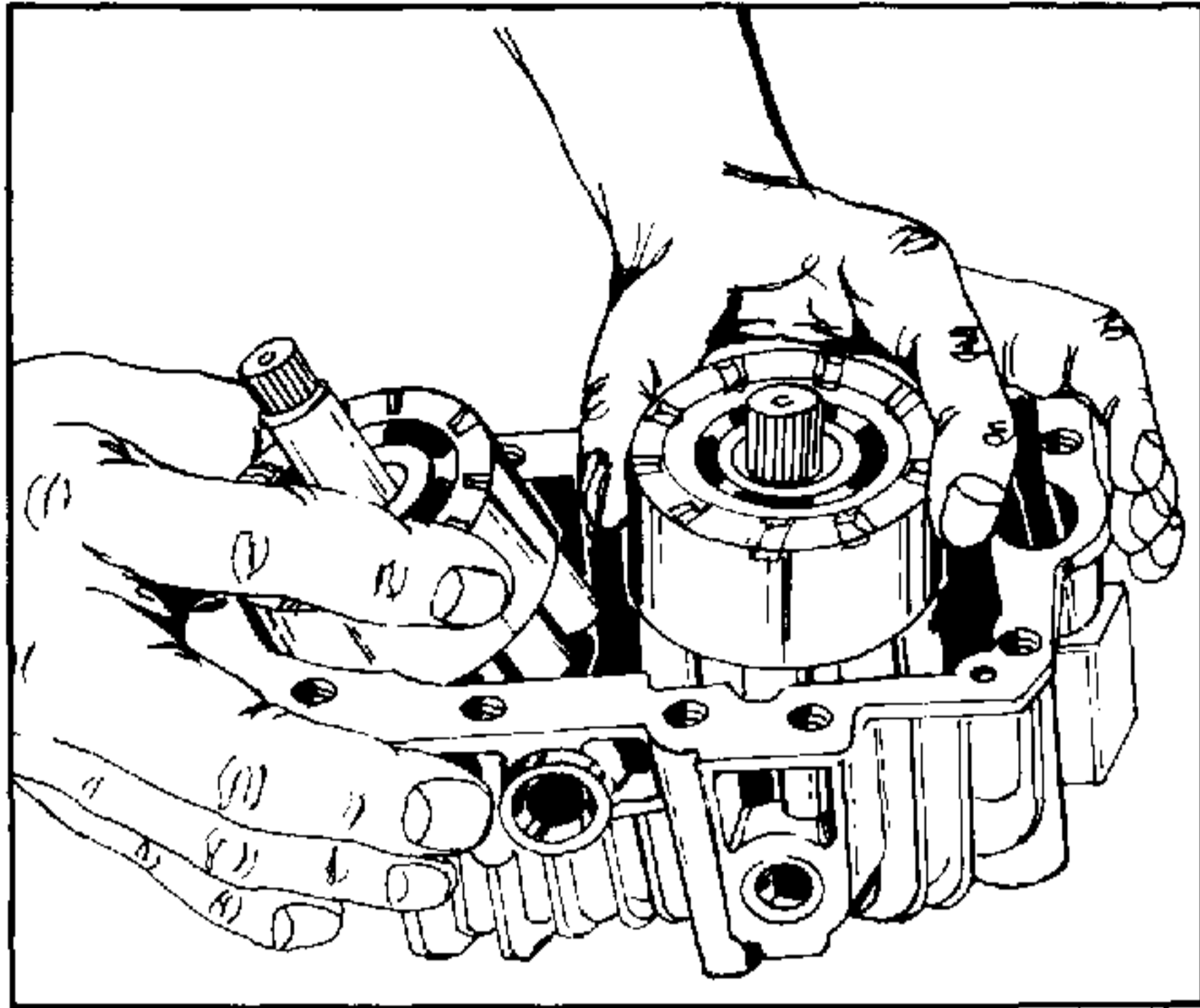

FIGURE 47.

5.4 Check cylinder block kits to rotate lightly.

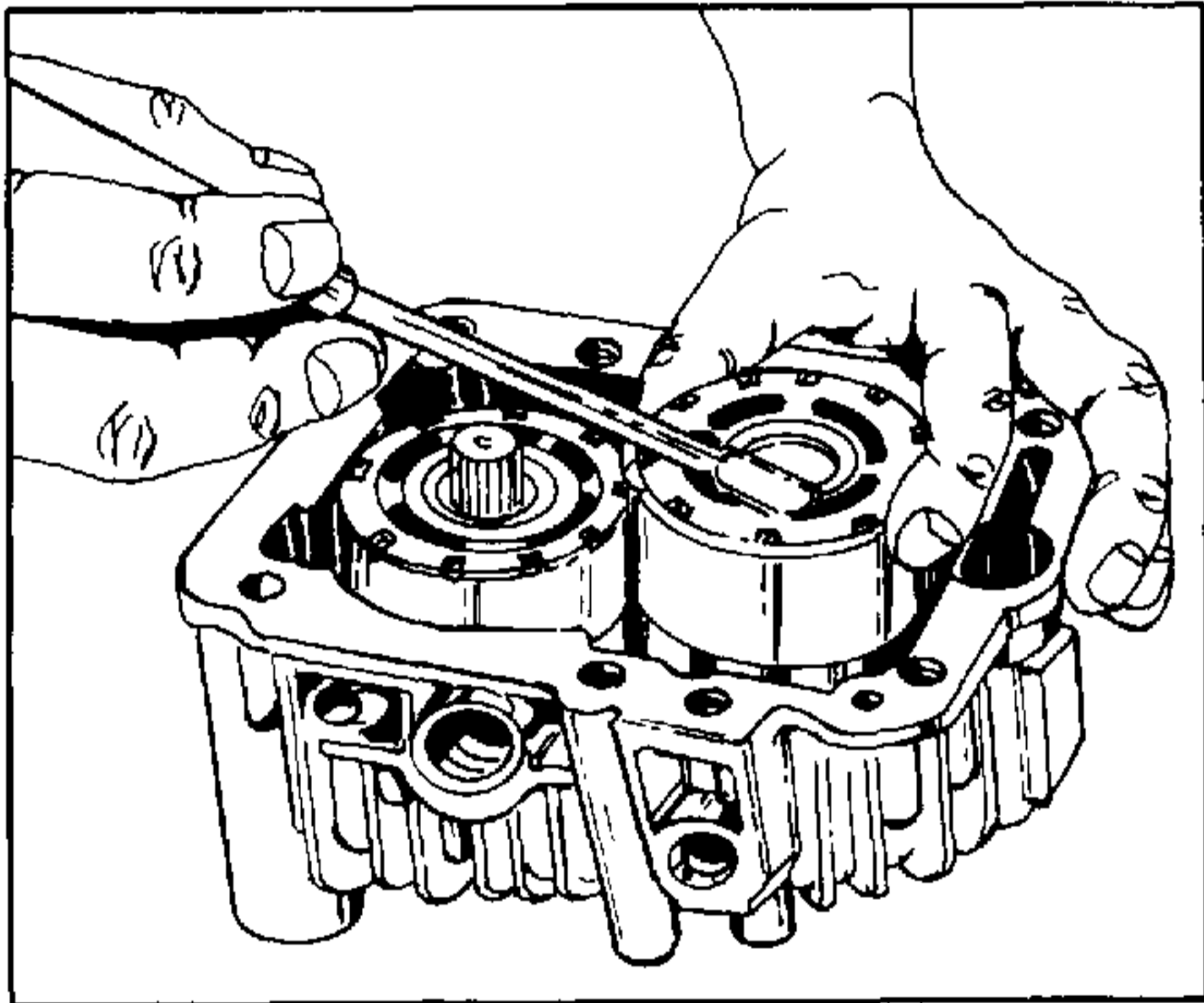

FIGURE 48.

5.5 Check piston springs to be in place. If they are out of place, set them to be in place with small driver.

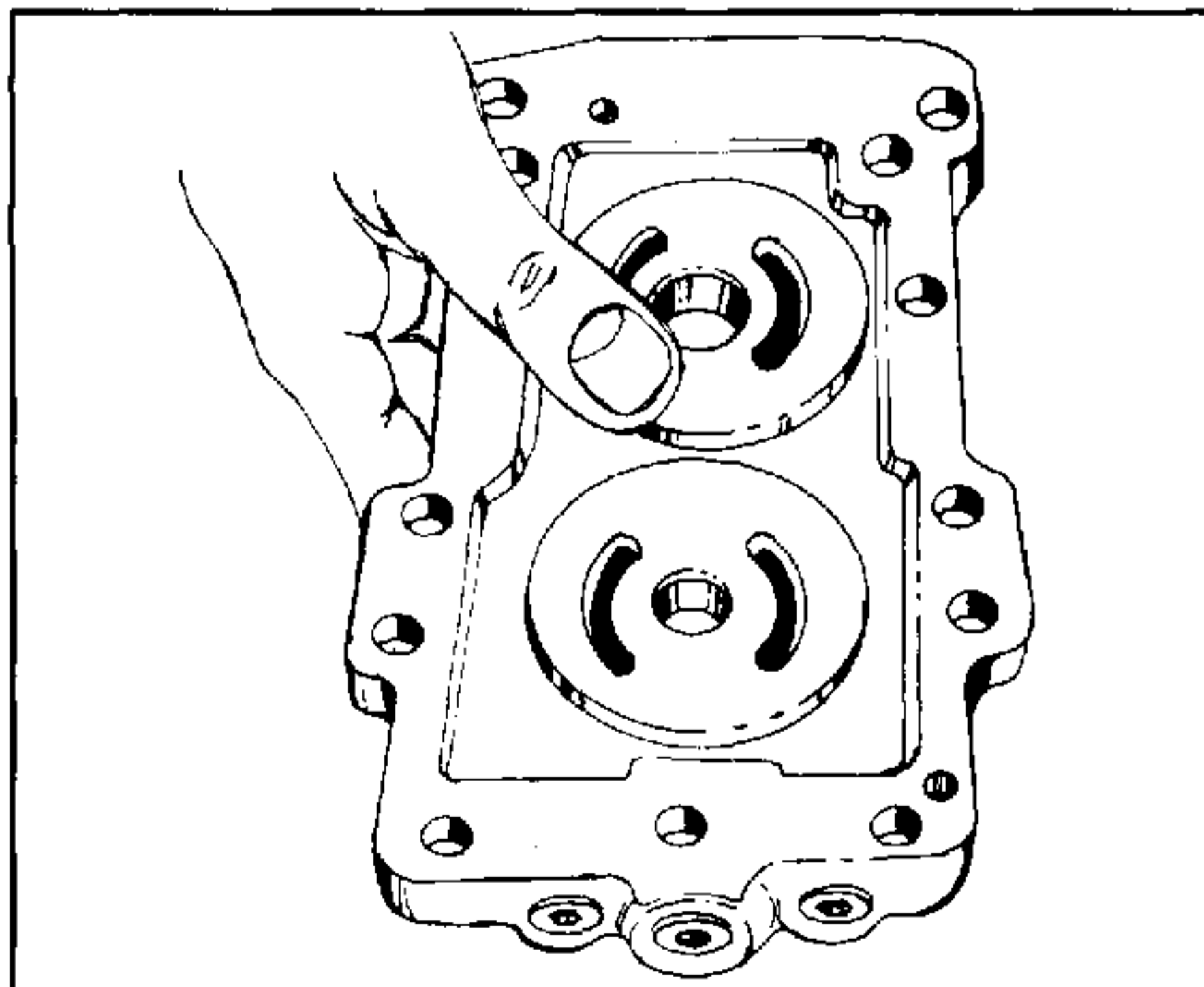

FIGURE 49.

6. Center section

6.1 Examine the wear surface of center section for excessive scratching or heavy wear patterns.

When the surface of center section is worn down more than 0.01 mm, exchange the center section for new one.

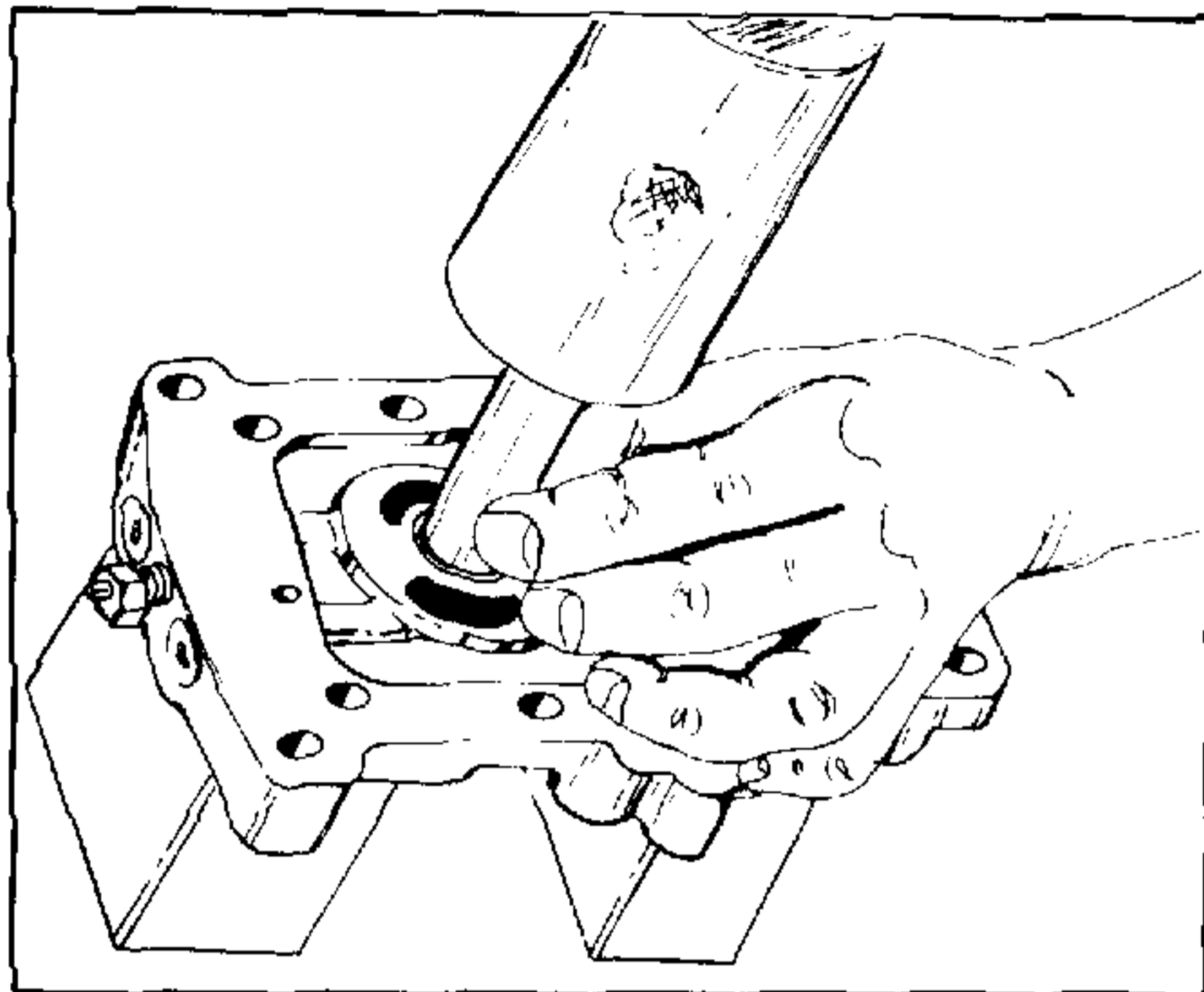

FIGURE 50.

6.2 Press the needle bearing into the center section.

TOOL: HAMMER, PRESS TOOL (PIPE etc.)

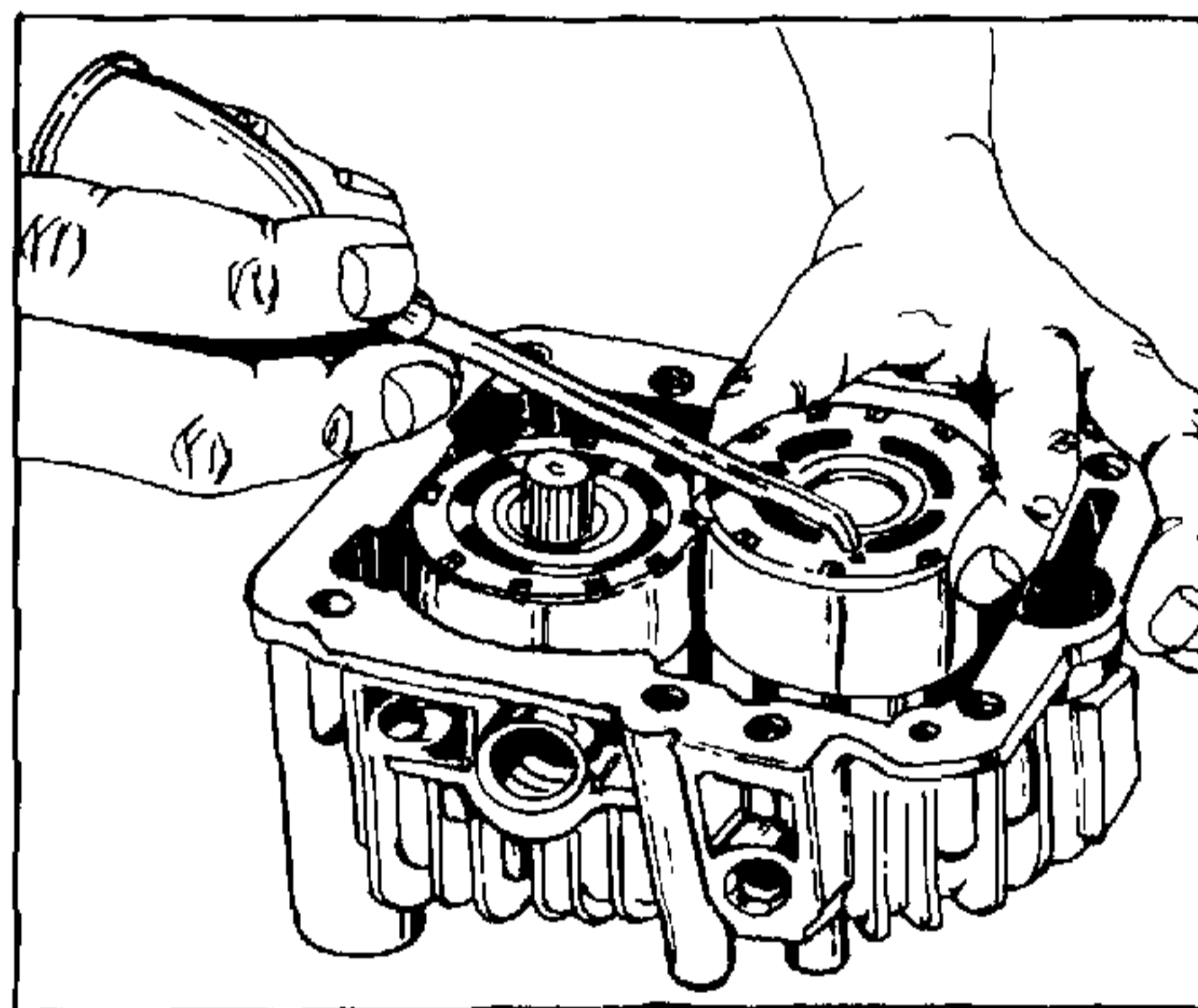

FIGURE 51.

6.3 Lubricate the exposed face of cylinder block with clean hydraulic oil.

Check locating pins (2 places) to place in the housing.

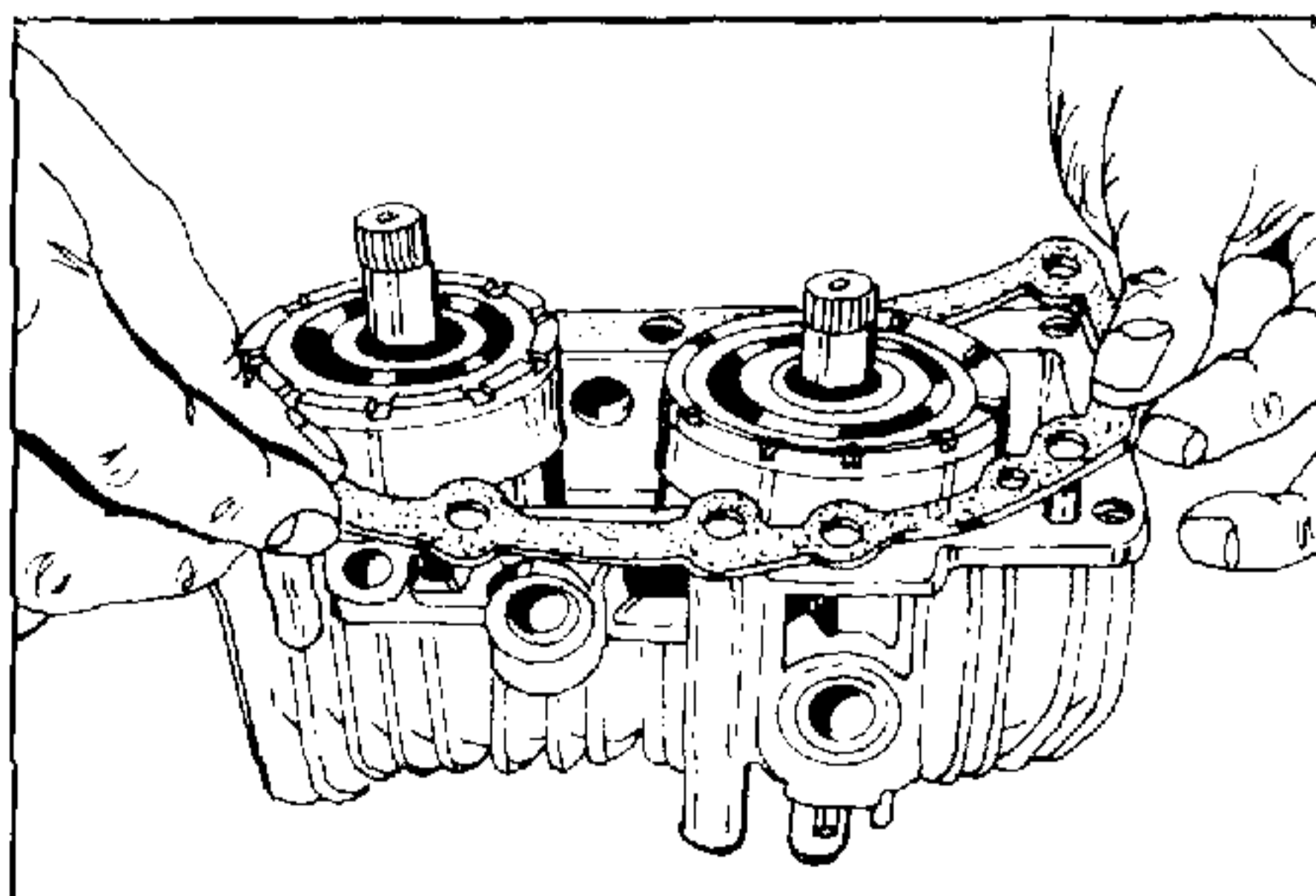

FIGURE 52.

6.4 Place a new gasket on the housing.

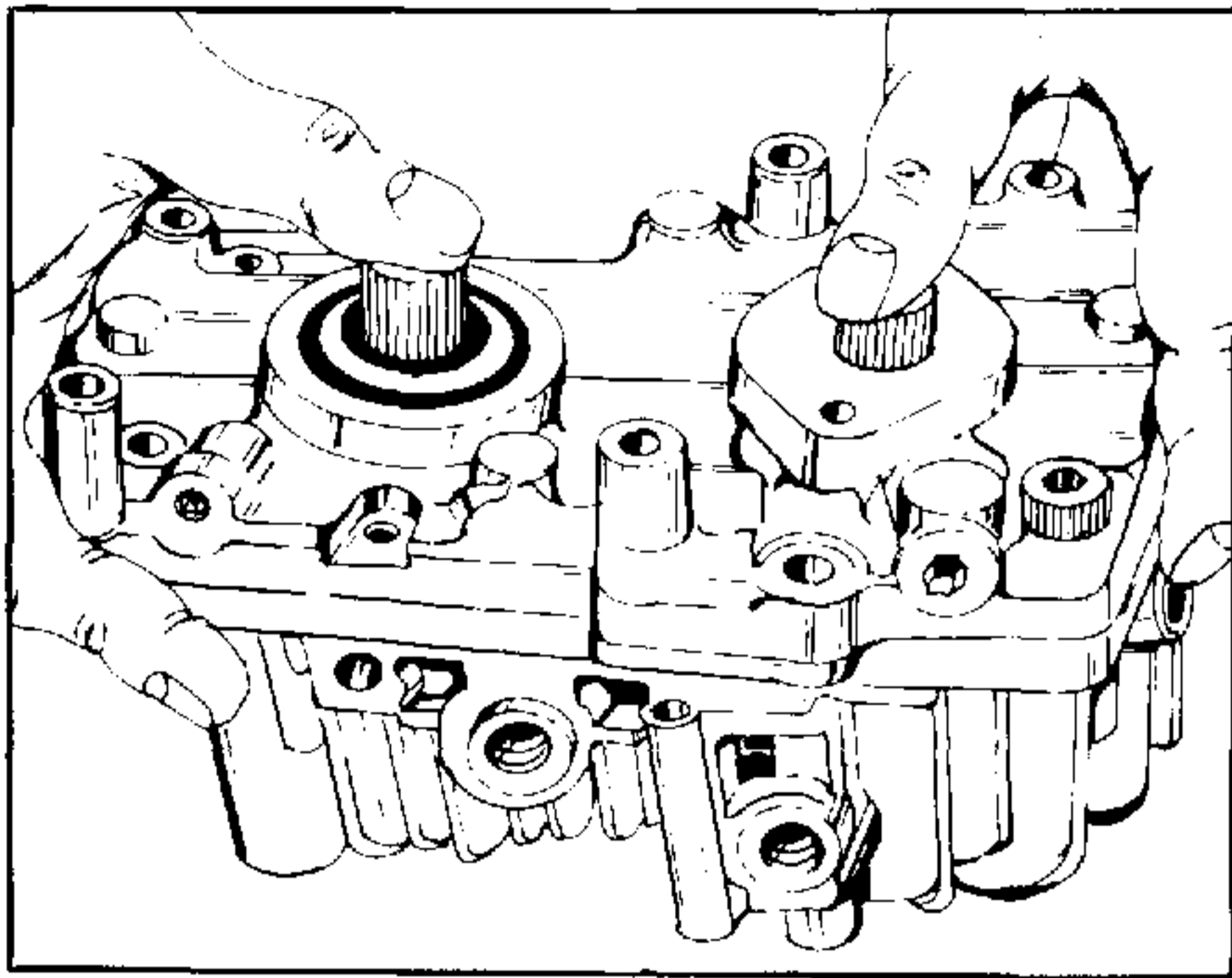

FIGURE 53.

- 6.5 Place the center section onto the housing.
Take care not to damage the center section
and the housing.

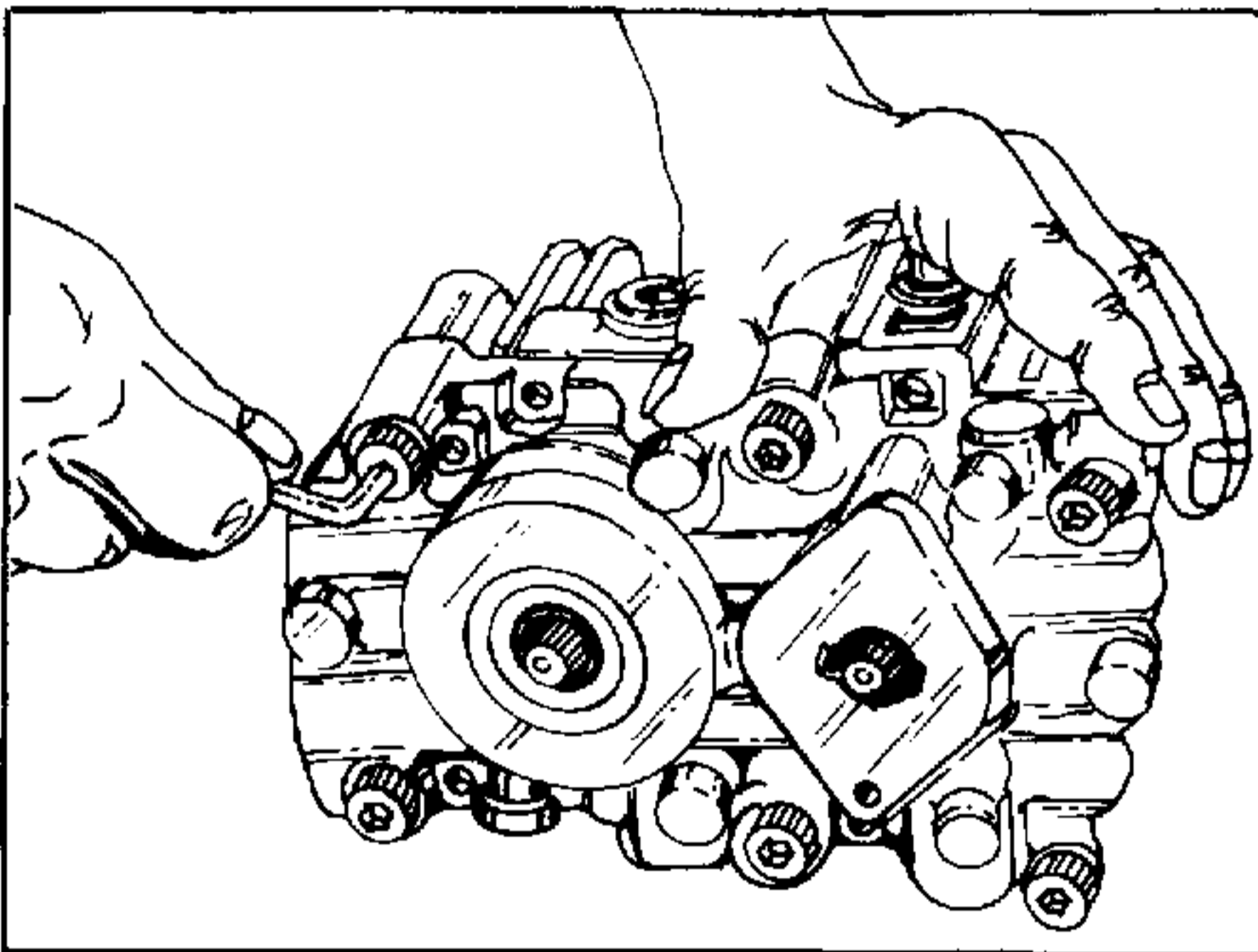

FIGURE 54.

- 6.6 Insert eight flat head screws.
SCREW—FLAT HD.: M8 × 35 QTY 4
M8 × 20 QTY 4
TOOL: HEX SOCKET SCREW KEY
Longer screws are inserted in outer bores of
the center section.

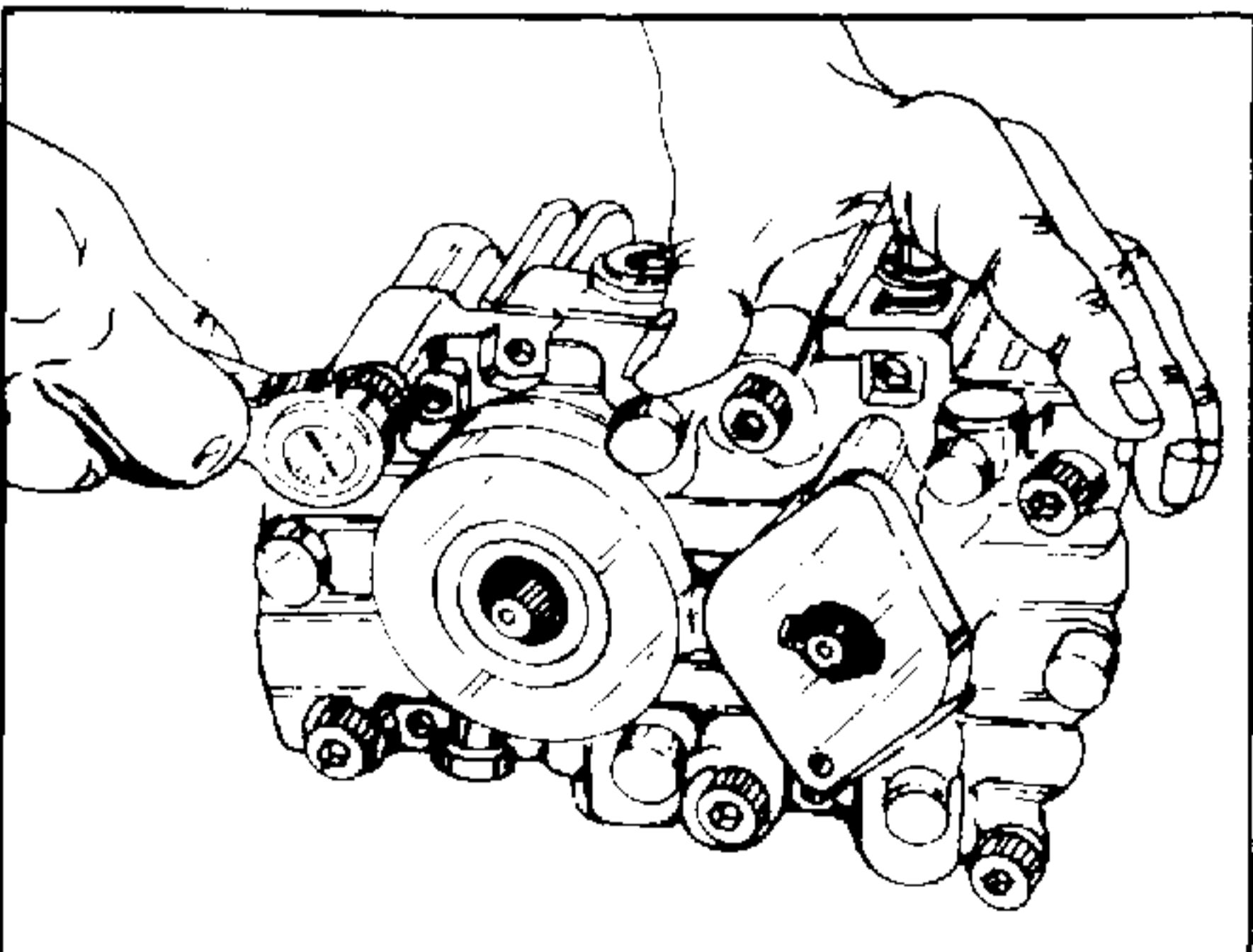

FIGURE 55.

- 6.7 Tighten these screws equally and pull two
sections (housing and center section)
together completely.
TOOL: HEX SOCKET SCREW KEY
TIGHTENING TORQUE: 160-190kgf•cm

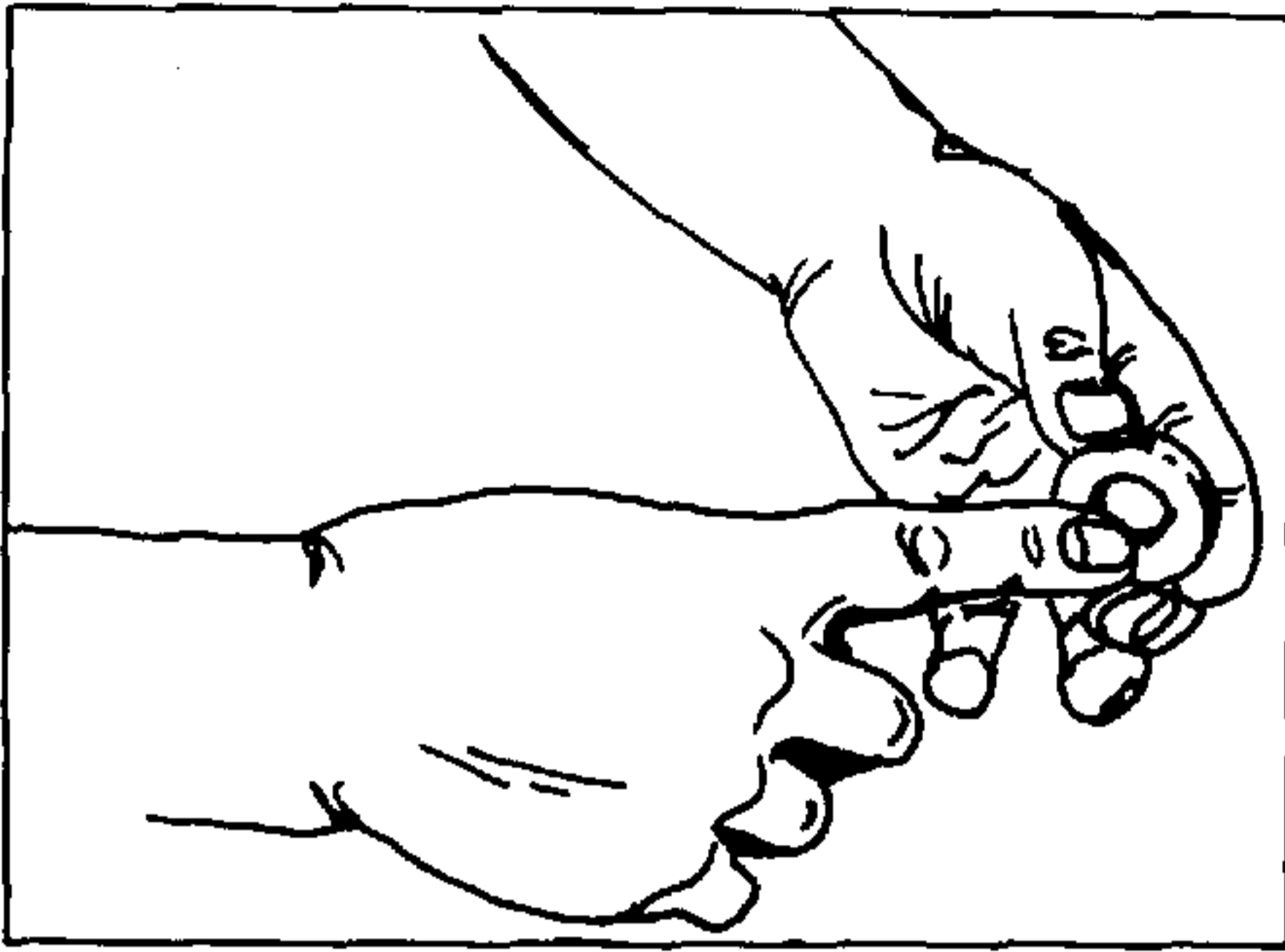

FIGURE 56.

6.8 Coat new oil seal lip with grease.

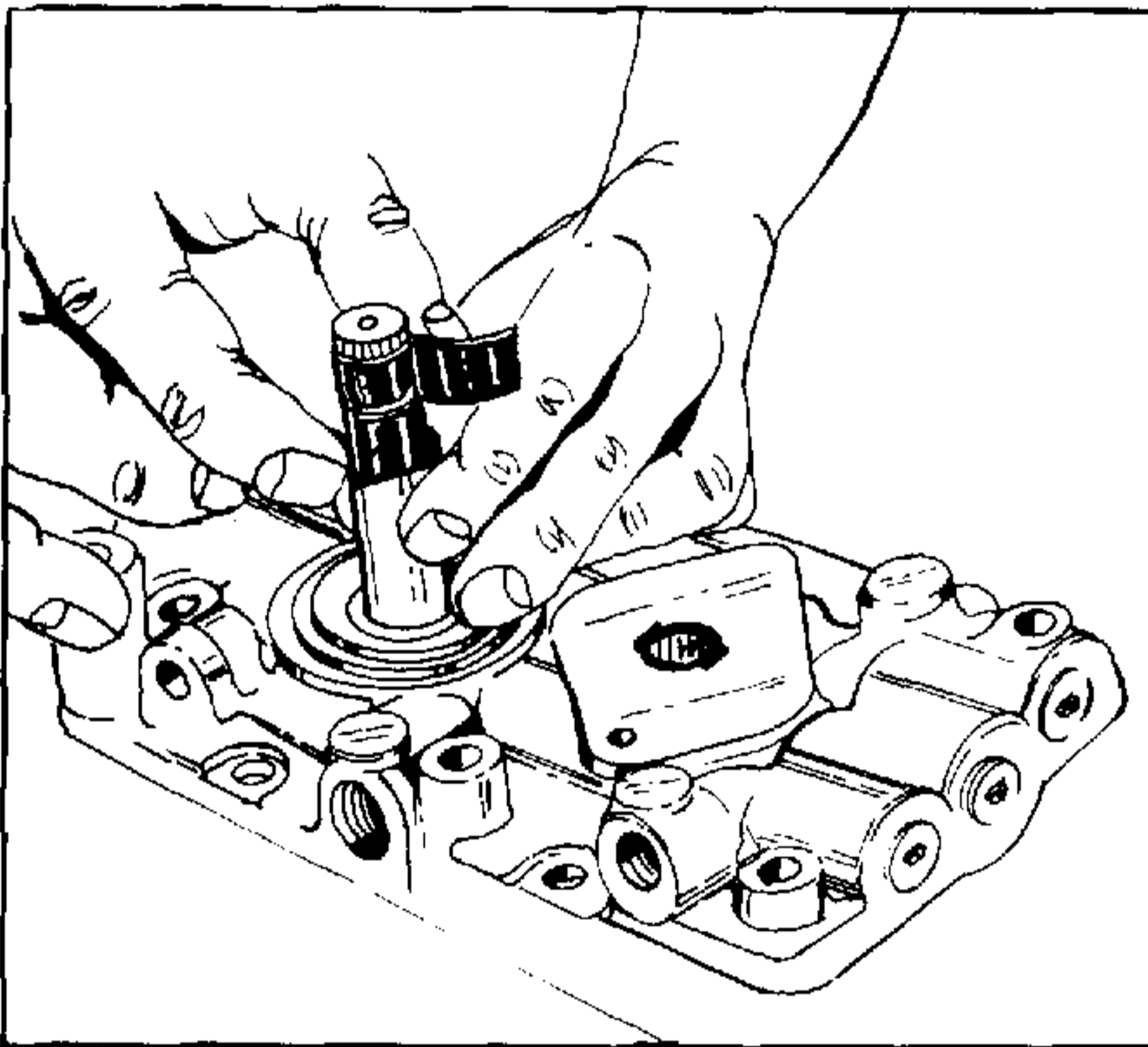

FIGURE 57.

6.9 Cover the shaft with thin tape to protect oil seal lip.

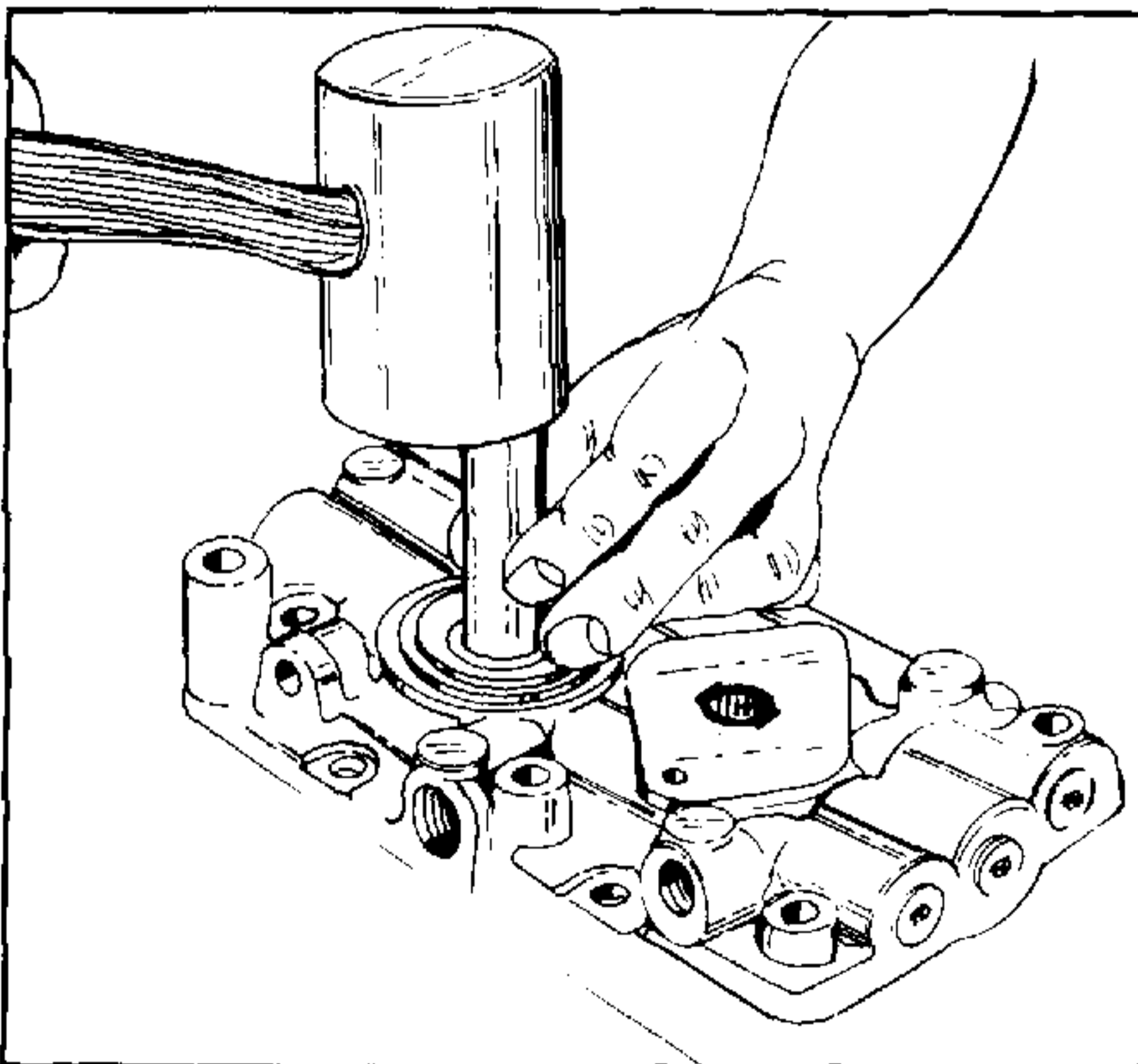

FIGURE 58.

6.10 Press the seal into the center section.
TOOL: HAMMER, PRESS TOOL (PIPE etc.)

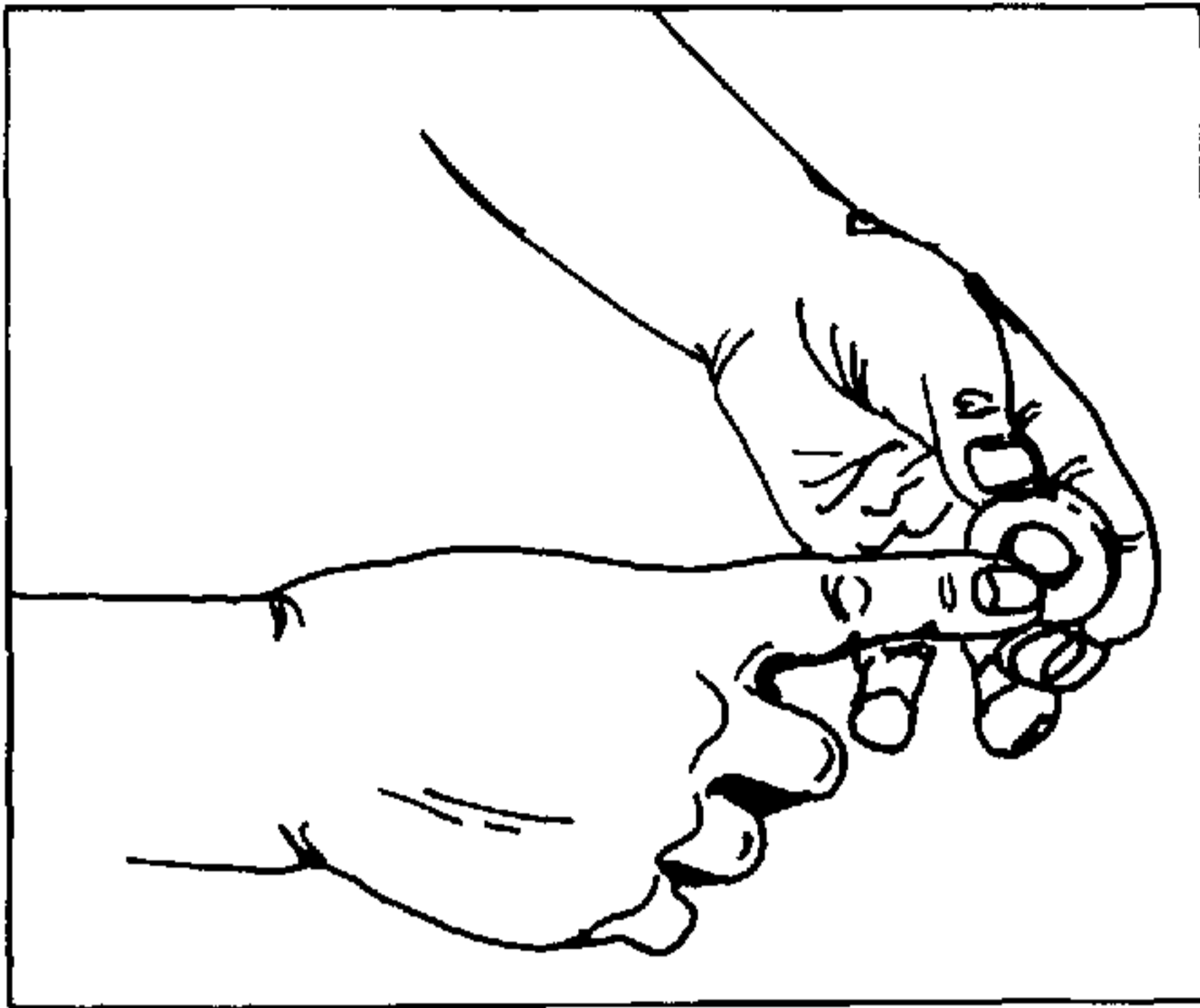

FIGURE 59.

7. Trunnion arm seal

7.1 Coat new oil seal lip with grease.

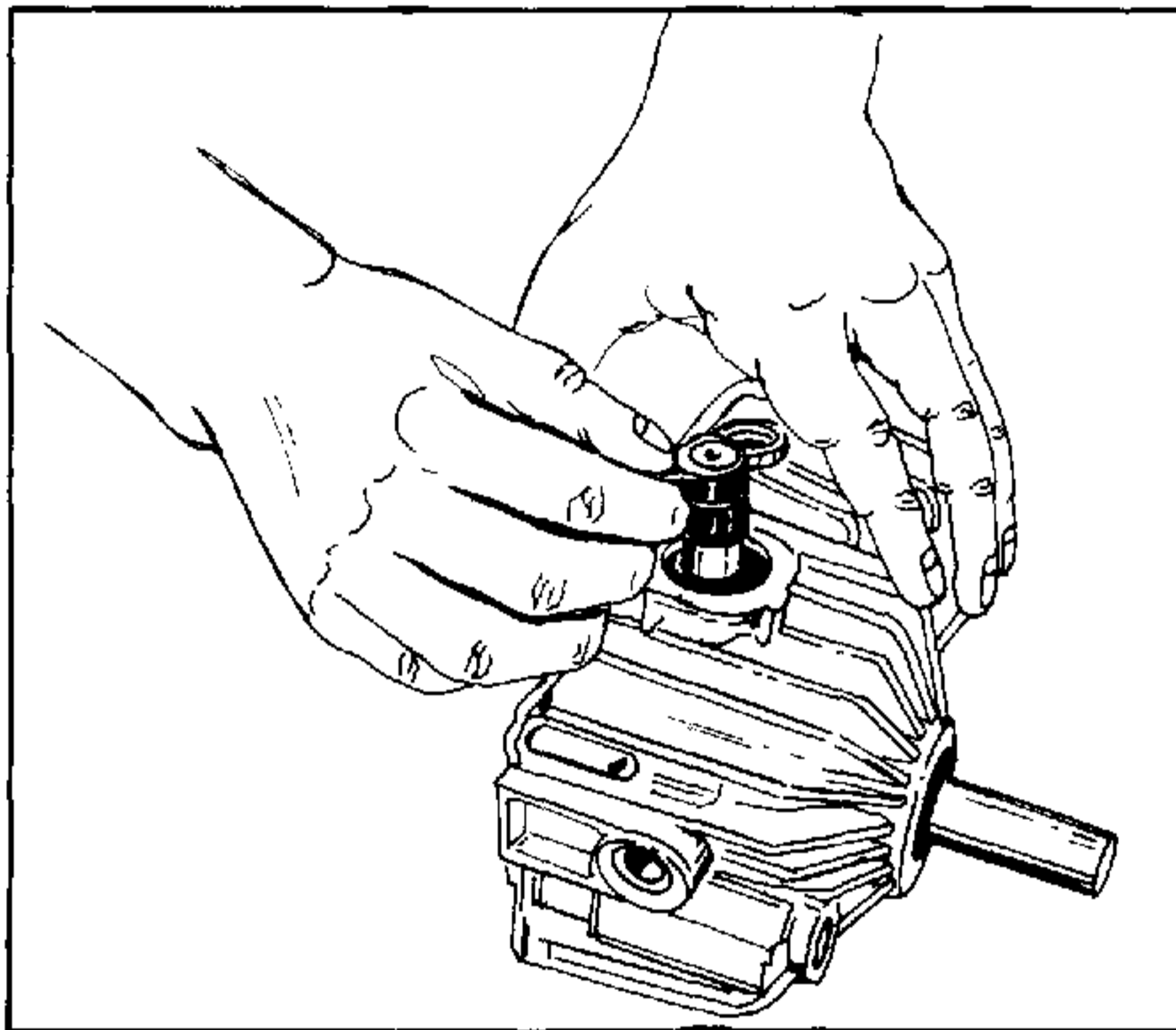

FIGURE 60.

7.2 Cover the trunnion arm with thin tape to protect oil seal lip.

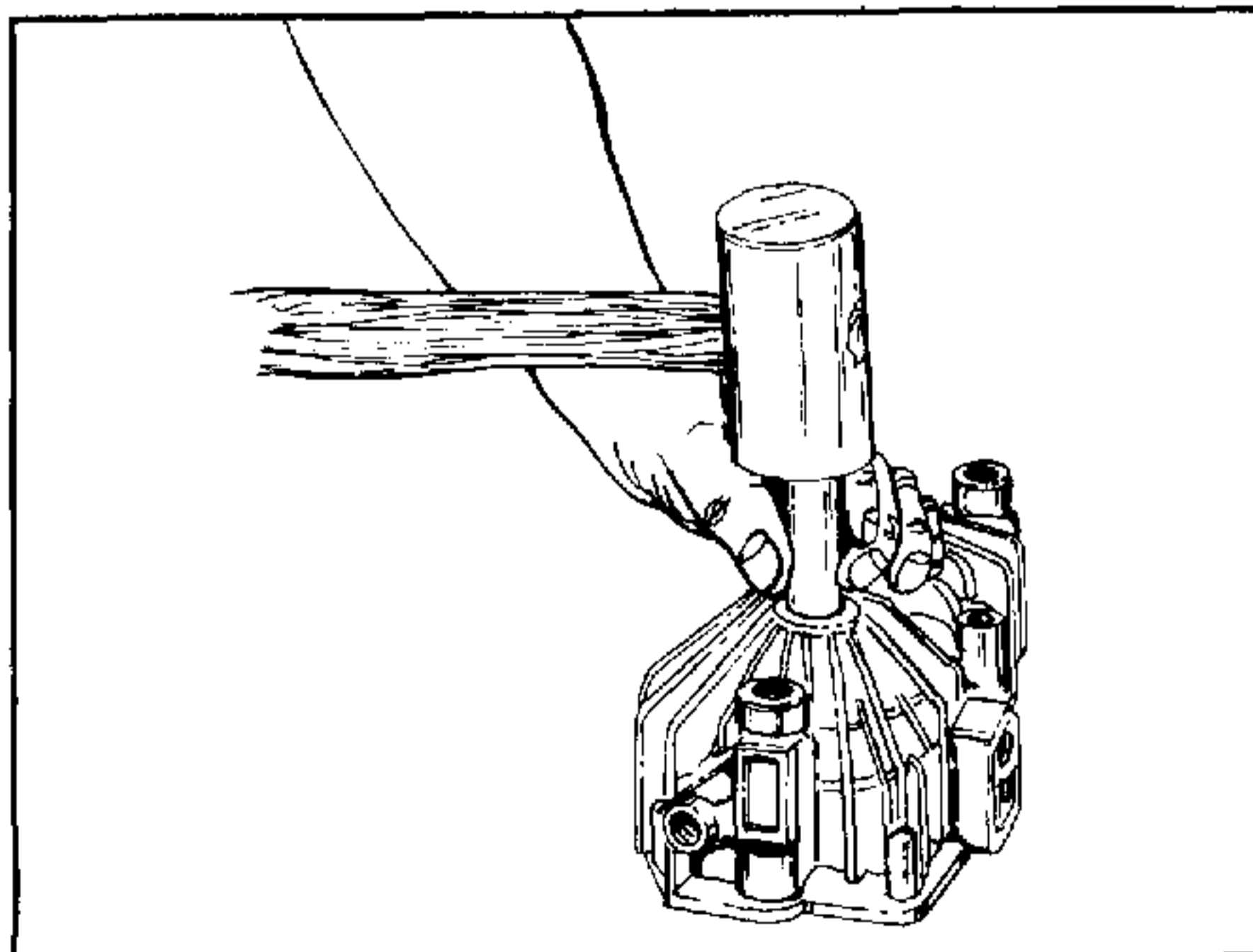

FIGURE 61.

7.3 Press the seal into the housing.
TOOL: HAMMER, PRESS TOOL (PIPE etc.)

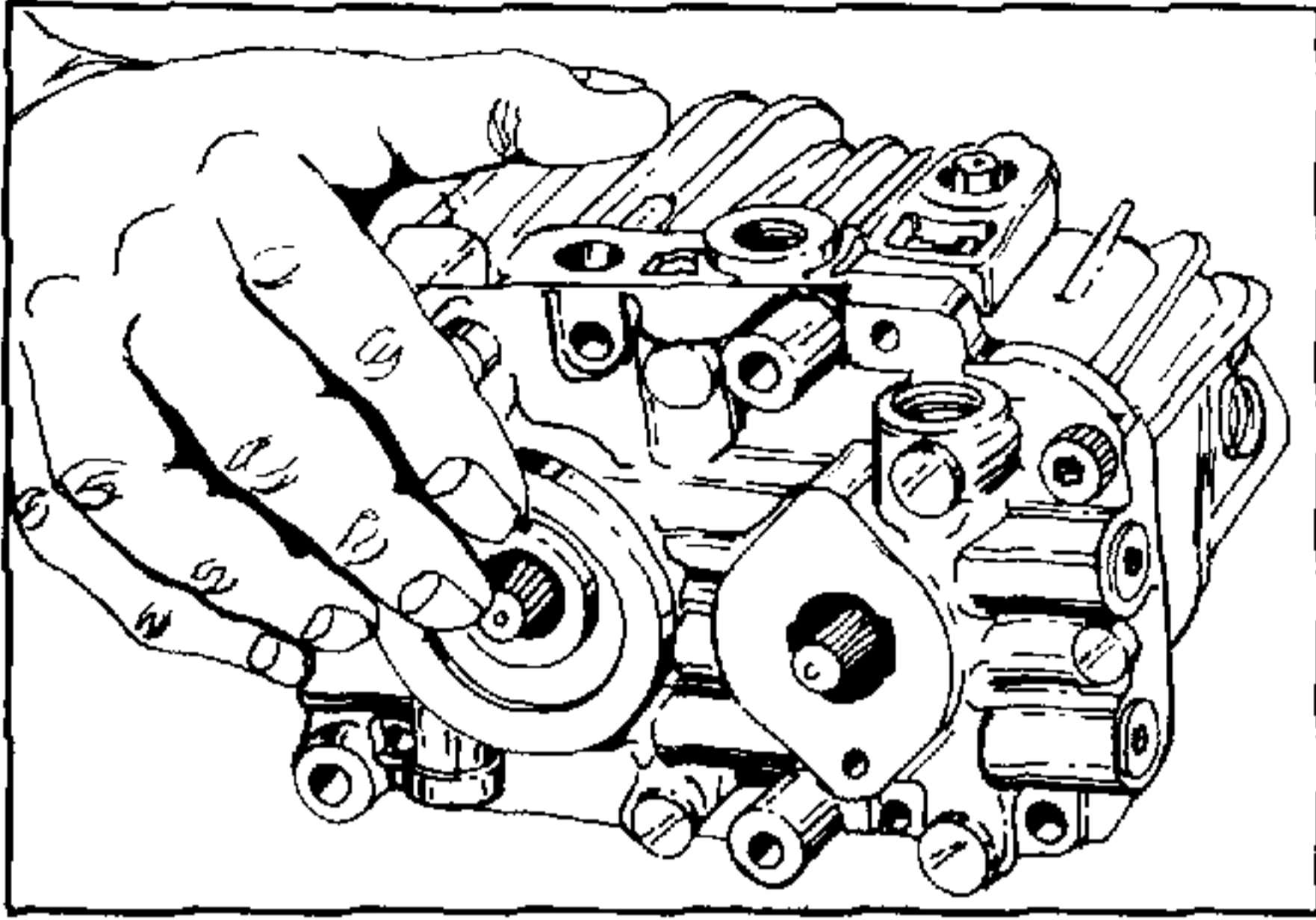

FIGURE 62.

8. Check valve

8.1 Lay the transmission on its side.

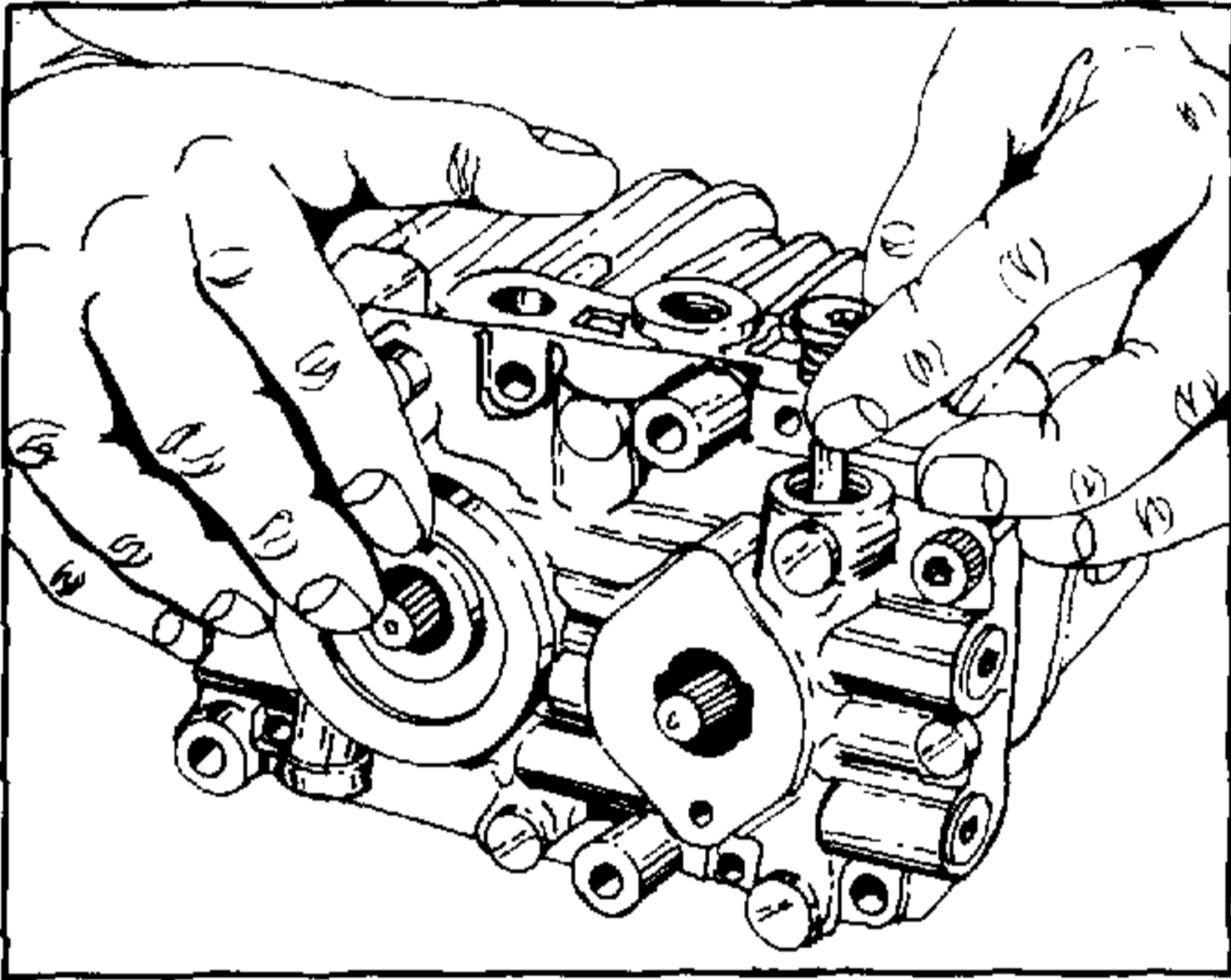

FIGURE 63.

8.2 Install the ball, the spring and the plug.

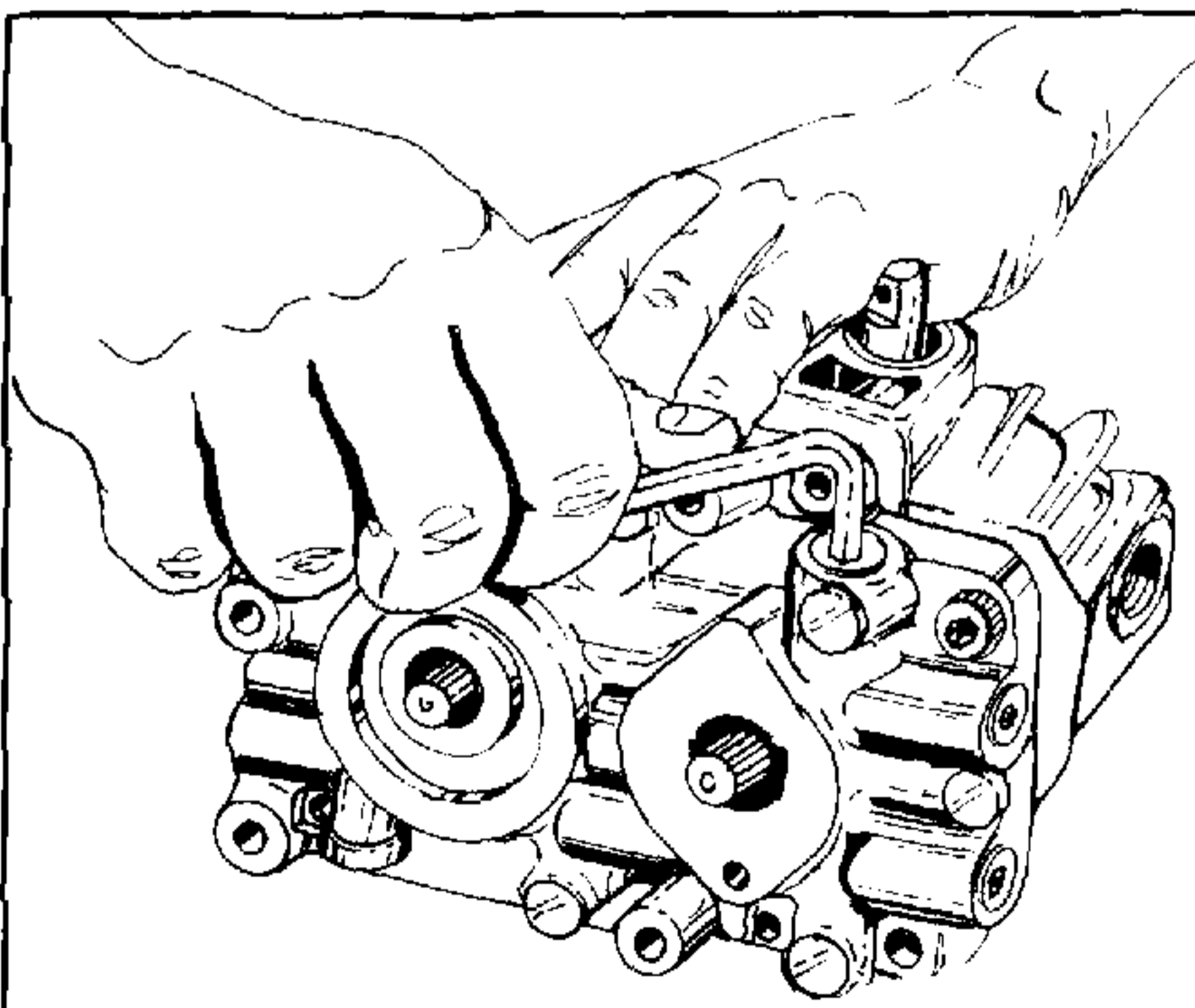

FIGURE 64.

8.3 Tighten the plug.

PLUG: 9/16-18

TOOL: HEX SOCKET SCREW KEY

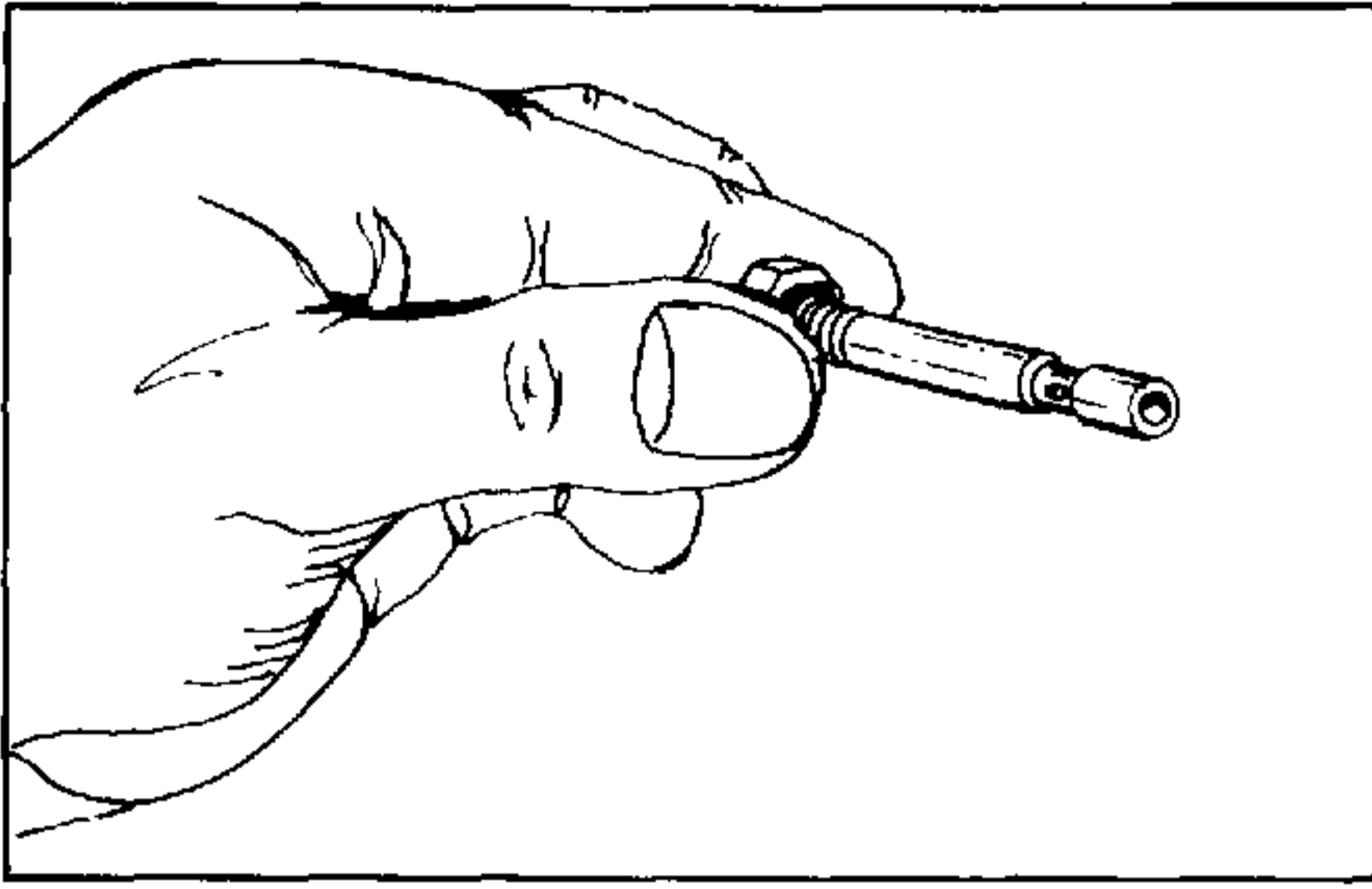

FIGURE 65.

9. By-pass valve

- 9.1 Exchange the o-ring if necessary.
O-RING: 1A-P3

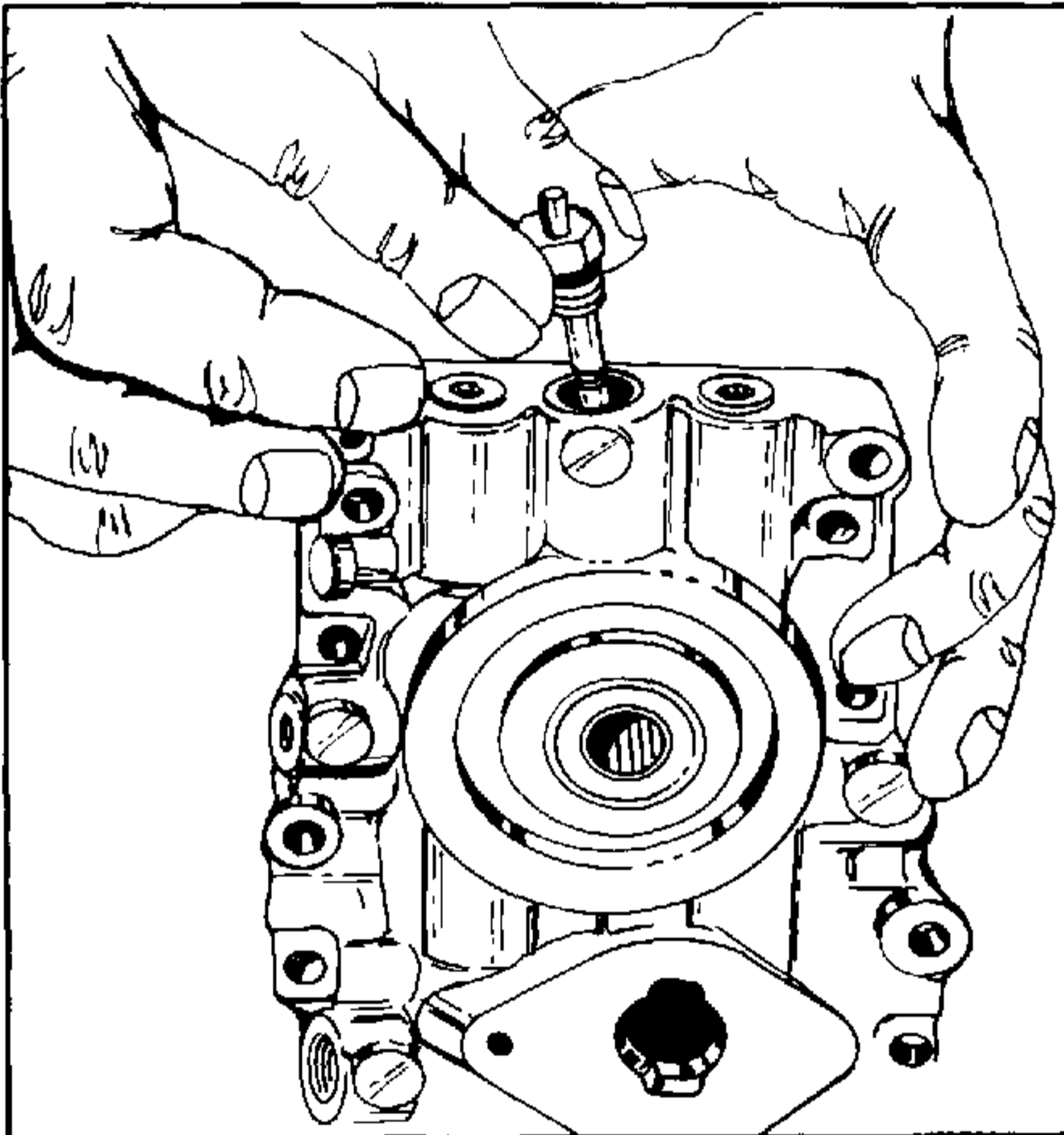

FIGURE 66.

- 9.2 Install the spring, by-pass spool and plug in that order.

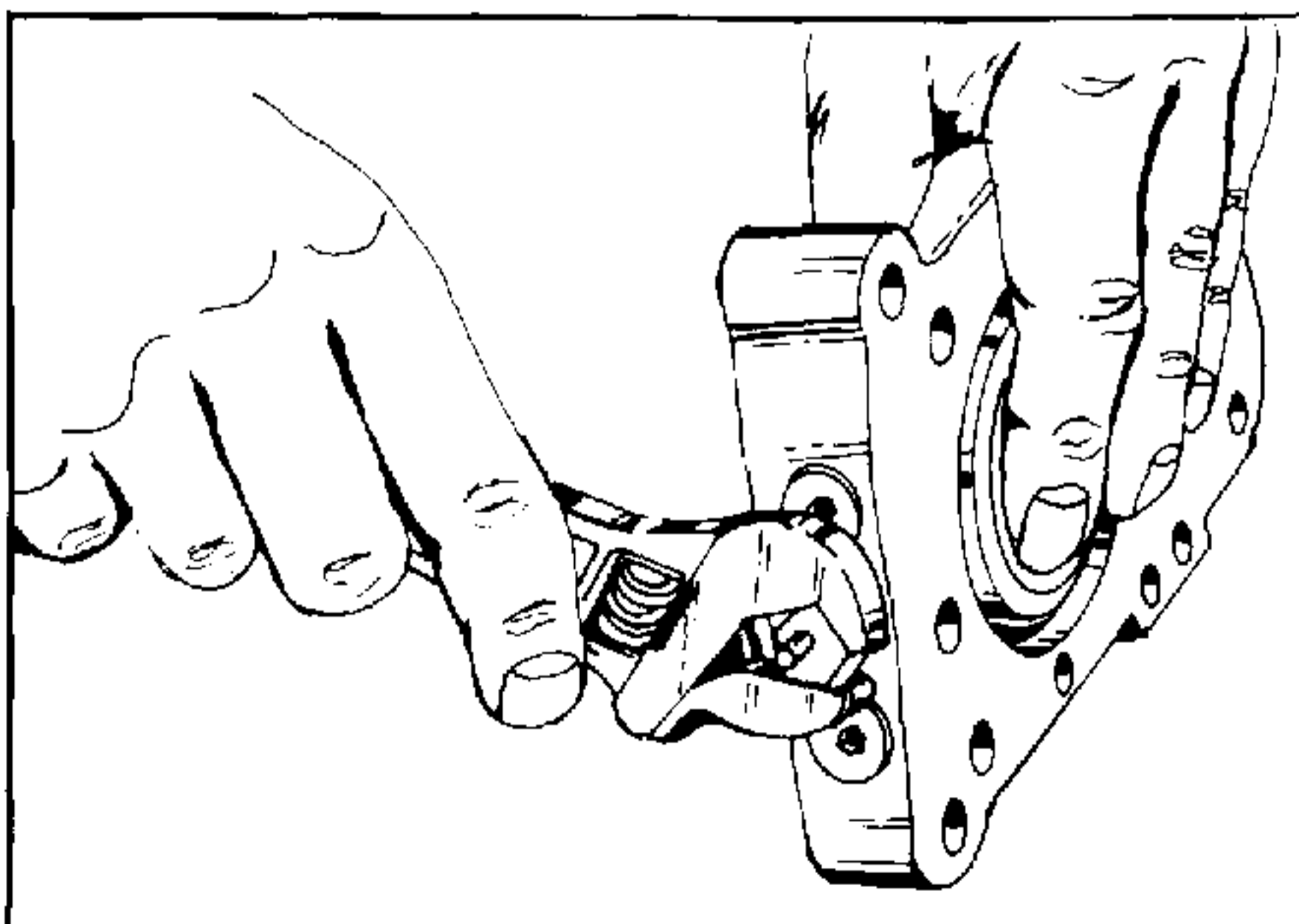

FIGURE 67.

- 9.3 Tighten the plug.
TOOL: SPANNER

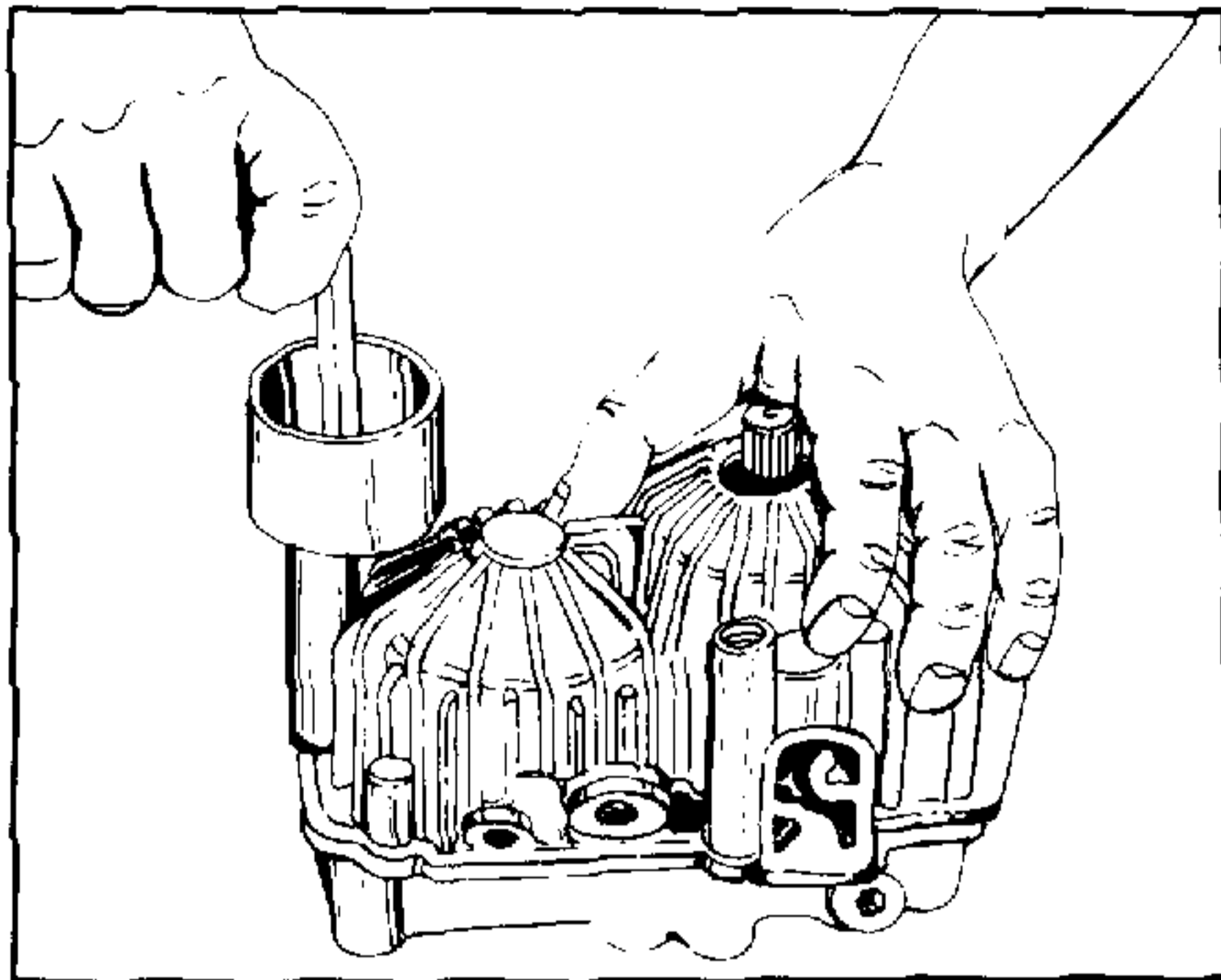

FIGURE 68.

10. Oil tank assembly

10.1 Screw the oil tank on the housing.

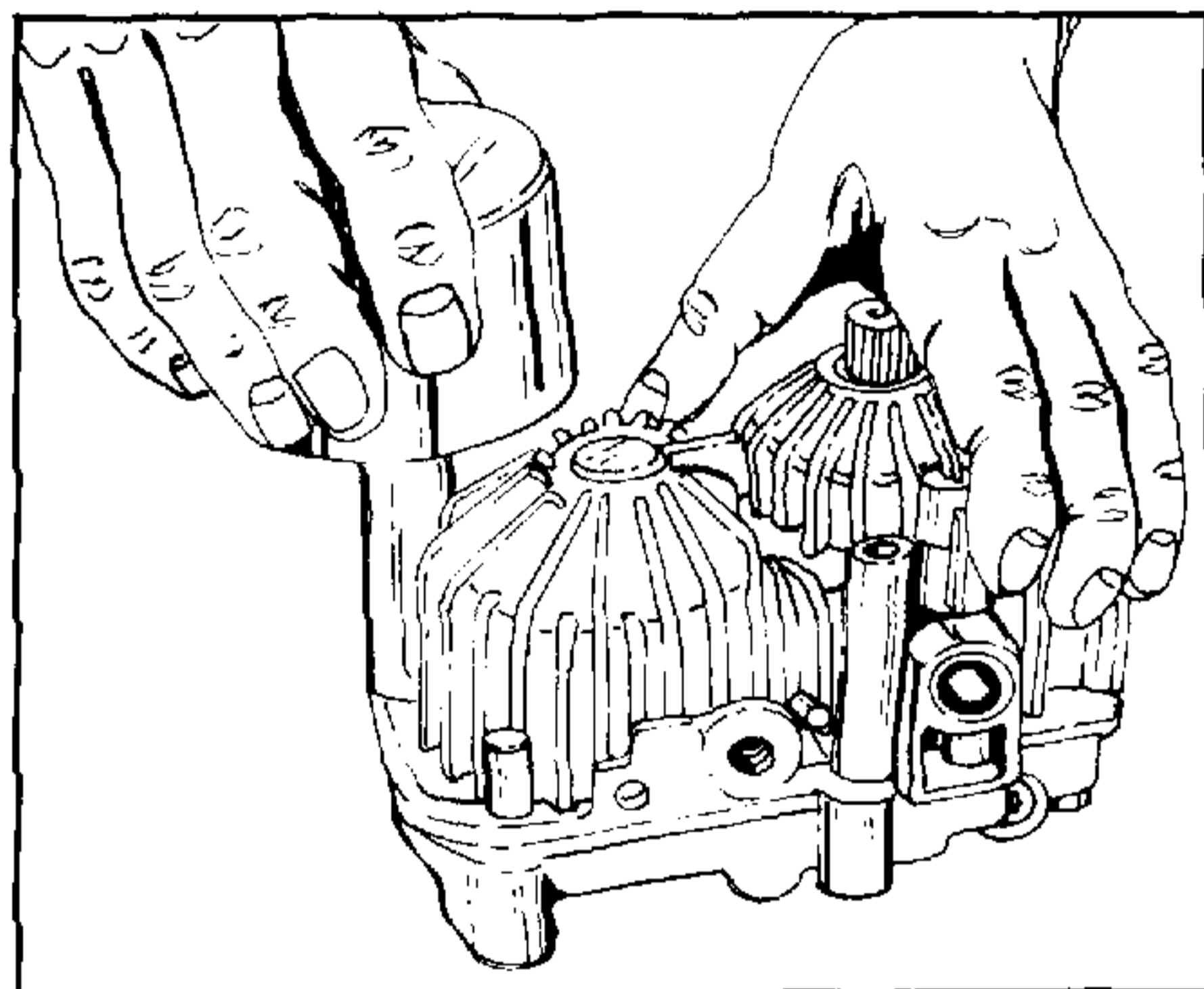

FIGURE 69.

10.2 Screw the cap on.

(This cap has a left-handed thread.)

REPAIR PARTS LIST
BDU-10S-114
BDU-10S-217

REF NO	PART NAME	QTY	REMARKS
1.	Ring—Retaining	1	JIS B 2804 For Hole 35
2.	Seal Lip	1	NOK TC-15-35-7
3.	Spacer (Seal Lip)	1	
4.	Ball Bearing	1	#6202
5.	Ring—Retaining	4	
*6.	Shaft (Pump)	1	
7.	Seal Lip	1	NOK-TC-12-25-7
8.	Journal Bearing (Control)	1	
9.	Trunnion Arm	1	
10.	Slot Guide	1	
11.	Cradle Bearing (Journal)	2	
12.	Swashplate Assy	1	
13.	Thrust Roller	1	
14.	Thrust Plate	1	
15.	Cylinder Block (Pump) Kit	1	
15-1.	Cylinder Block (Pump)	(1)	
15-2.	Piston	(5)	
15-3.	Thrust Washer (Piston)	(5)	
15-4.	Spring Piston	(5)	
*16.	Center Section Assy	1	
*16-1.	Center Section	(1)	
16-2.	Journal Bearing (Shaft)	(1)	
17.	Plug Socket Head	1	
18.	Plug Socket Head	4	
19.	Ball (Check)	2	JIS B 1501 3/8
20.	Spring (Check)	2	
21.	"O"-Ring	2	
22.	Plug Check	2	
23.	Housing Assy	1	
23-1.	Housing	(1)	
23-2.	Journal Bearing (Shaft)	(1)	
24.	Gasket	1	
25.	Pin (Straight)	2	
26.	Washer (Shaft)	2	
27.	Spring (Block)	1	
28.	Thrust Ball Bearing Assy	1	#51106
*29.	Shaft (Motor)	1	
30.	Cylinder Block (Motor) Kit	1	
30-1.	Cylinder Block (Motor)	(1)	
30-2.	Piston	(5)	
30-3.	Thrust Washer (Piston)	(5)	
30-4.	Piston Spring	(5)	
31.	Needle Bearing	1	
32.	Spring (Bypass)	1	
33.	Bypass Spool	1	
34.	"O"-Ring	1	JIS B 2401 1A-P3
35.	"O"-Ring	1	
36.	Plug (Bypass)	1	
37.	Name Plate	1	
38.	Screw (Socket Head)	4	JIS B 1176 M8*20
39.	Screw (Socket Head)	4	JIS B 1176 M8*35
40.	Seal Lip	1	NOK TC-15-24-7

REPAIR PARTS LIST
BDU-10S-114
BDU-10S-217

REF NO	PART NAME	QTY	REMARKS
41.	Plug (Socket Head)	4	
42.	Plastic Plug	1	
43.	Spring (Filter)	1	
44.	Washer (Filter)	1	
45.	Filter	1	
*46.	Seal Lip	1	NOK TCV-12.7-22.23-6.35

EXPLODED VIEW OF SUNDSTRAND BDU-10S-114
AND BDU-10S-217

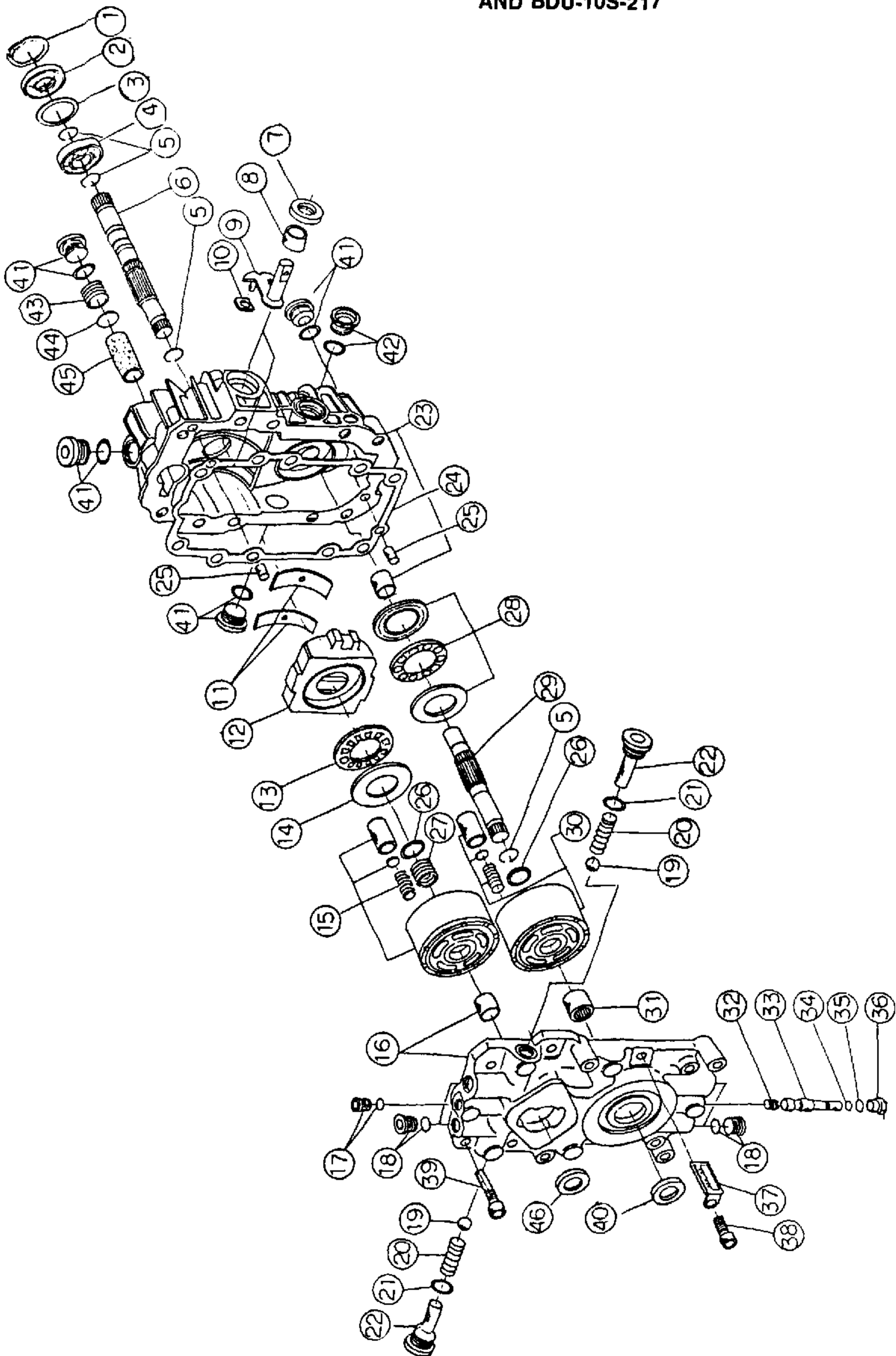

FIGURE 70.

MODEL #717-3048

SERVICE MENU

SECTION 1 TROUBLE SHOOTING

- 1.00 Tractor will not move forward or reverse.
- 1.10 Overheating.
- 1.20 Brake fails to stop vehicle or hold on hills.
- 1.30 Transmission leaks oil or grease.

SECTION 2 BRAKE ADJUSTMENT AND REPAIR

SECTION 3 DAMAGED INPUT ASSEMBLY

SECTION 4 HYDRO TRANSMISSION REMOVAL

SECTION 5 TRANSAXLE REPAIR

- 5.30 Damaged driven pinion.
- 5.40 Damaged pinion shaft.
- 5.50 Final drive/differential.
- 5.60 Axle shaft replacement.

SECTION 6 HOUSING CRACKED OR BROKEN

- 6.20 Stripped threads.

SECTION 7 DAMAGED BALL BEARINGS

SECTION 8 TRANSAXLE REASSEMBLY

GENERAL PRINCIPLES

Prerequisite for good repair work.

- A. Study cross-sectional views to refamiliarize yourself with the product.
- B. Move the article to be repaired into a well lit and clean work area.
- C. Keep clean rags or paper towels on hand.
- D. Find section in repair manual covering your particular problem and study in depth.
- E. Acquire or make specialized tools and keep orderly in reach.
- F. After disassembly, wash all parts, arrange in order and inspect under a good light to determine the extent of damage including possible damage that occurred as a result of the primary part failure.
- G. Replace all damaged and questionable parts and always replace fasteners with locking devices and retaining rings.
- H. Lubricate parts used in reassembly.

HYDRO TRANSAXLE ASSEMBLY

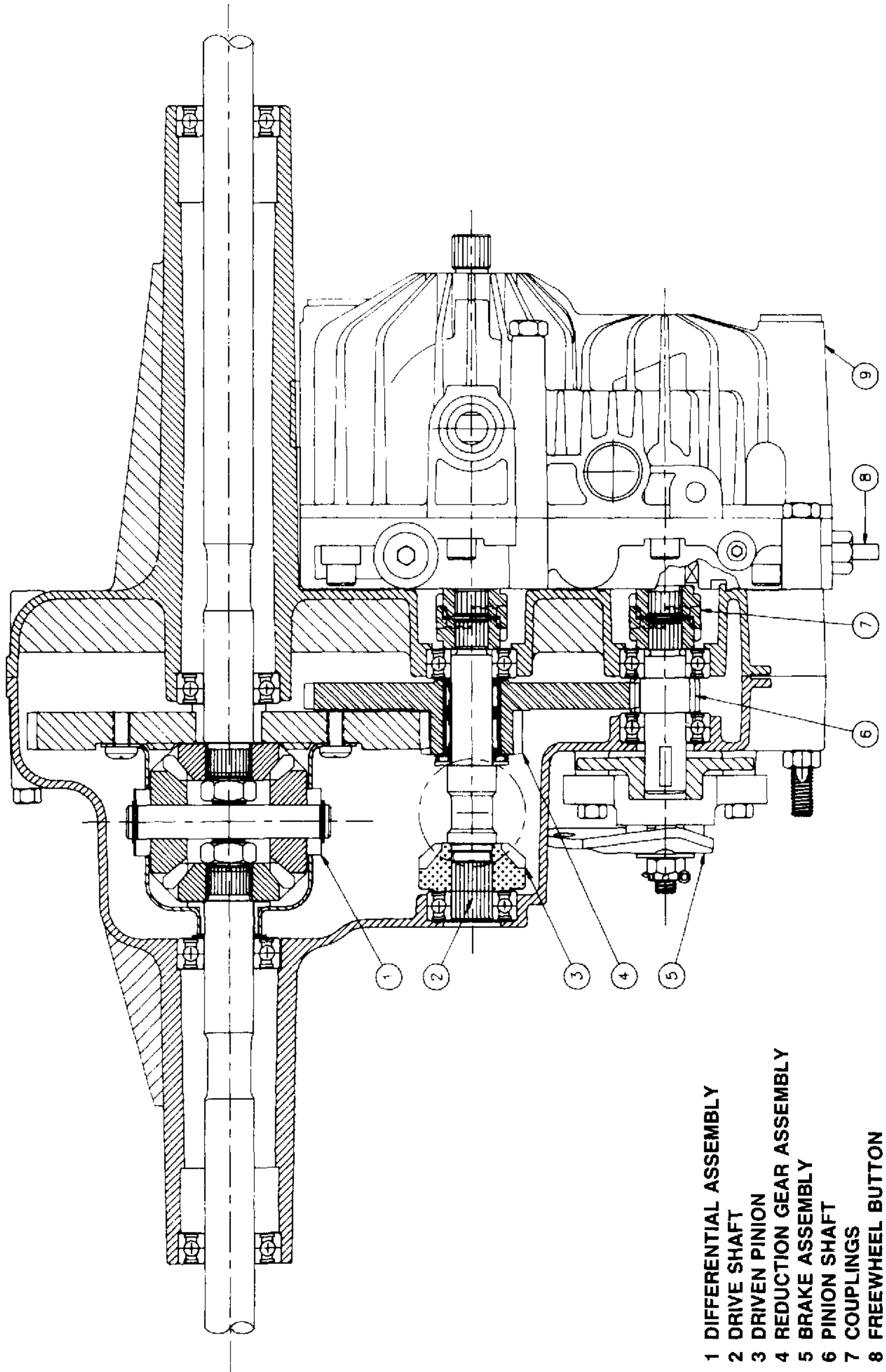

- 1 DIFFERENTIAL ASSEMBLY
- 2 DRIVE SHAFT
- 3 DRIVEN PINION
- 4 REDUCTION GEAR ASSEMBLY
- 5 BRAKE ASSEMBLY
- 6 PINION SHAFT
- 7 COUPLINGS
- 8 FREEWHEEL BUTTON
- 9 HYDROSTATIC TRANSMISSION

SECTION 1 TROUBLE SHOOTING

TRACTOR WILL NOT MOVE FORWARD OR REVERSE.

(WARNING! DO NOT ATTEMPT ANY ADJUSTMENTS WITH ENGINE RUNNING.)

- 1.00 Check control linkages to directional control on hydro.
- 1.01 Important! Check oil level in reservoir on top of hydro. (See hydro specifications for oil type and quantities.)
- 1.02 Make sure freewheel button on hydro is fully released. (See Sundstrand Hydro transmission manual for replacement.)
- 1.03 Check input drive belt. Adjust or replace as needed. (See tractor manual for specifications.)
- 1.04 If the splined shaft on hydro is not rotating when input fan is rotating then refer to section 3 (DAMAGED INPUT ASSEMBLY) or section 4 (HYDRO TRANSMISSION REMOVAL).
- 1.05 If hydro shaft does rotate but brake disc does not, (When hydro directional control lever is not in neutral.) then refer to section 4 (HYDRO TRANSMISSION REMOVAL).
- 1.06 Make sure parking brake is released.

OVER HEATING

- 1.10 Important! Check oil level.
- 1.11 Oil must be within specified limits on reservoir.
- 1.12 Oil must be as specified in manual.
- 1.13 Check for broken or distorted cooling fan blades or, remove any obstructions such as grass clippings, leaves, dirt, etc., from cooling fins.
- 1.14 Check tractor manual not to exceed recommended load rating.
- 1.15 Be sure parking brake is fully released.
- 1.16 If parking brake is released but still braking, refer to section 2 (BRAKE ADJUSTMENT OR REPAIR).

BRAKE FAILS TO STOP VEHICLE OR HOLD ON HILLS.

- 1.20 The brake is located on the right side of the trans-axle. Find brake lever rod and depress brake several times to verify actuation of brake.
- 1.21 Adjust brake arm as specified in section 2.
- 1.22 Or brake pucks must be replaced. Section 2 (BRAKE ADJUSTMENT OR REPAIR).

TRANSMISSION LEAKS OIL OR GREASE.

- 1.30 Make sure oil reservoir on top of hydro is snug.

- 1.31 If oil leaks from shaft seals on hydro refer to the Sundstrand Hydro Transmission Manual for repairs.
- 1.32 Check transaxle housings for damage. See section 6 (HOUSING CRACKED OR BROKEN).
- 1.33 Retorque housing bolts to 80-120 Inch/LBS.
- 1.34 If ball bearings leak grease then go to section 7 (DAMAGED BALL BEARINGS).

SECTION 2 BRAKE ADJUSTMENT AND REPAIR

- 2.00 Disconnect brake rod from actuating arm.
- 2.10 The brake is factory set for a specific brake clearance. If brake is found to be out of adjustment then go to section 2.40 for readjustment.
- 2.20 To install new pads remove (2) bolts securing the brake yoke assembly.
- 2.21 Pull disc from shaft and inspect bearing area for grease leakage.
- 2.22 Remove (2) actuating pins from brake yoke assembly and check for excessive wear on pins or yoke.
- 2.30 Use a degreasing solvent to clean brake area thoroughly before reassembly.
- 2.31 Reassemble brake yoke assembly by reinstalling (2) actuating pins, (1) puck plate, and (1) brake puck. (Secure puck with scotch tape for ease of assembly.
- 2.32 Rebolt yoke assembly by using locktite #242.
- 2.40 Check gap between disc and puck with feeler gauge. (See figure 1.) Gap must be adjusted by tightening or loosening castle nut to .010 gap exactly.
- 2.50 Relink brake rod to actuating arm.

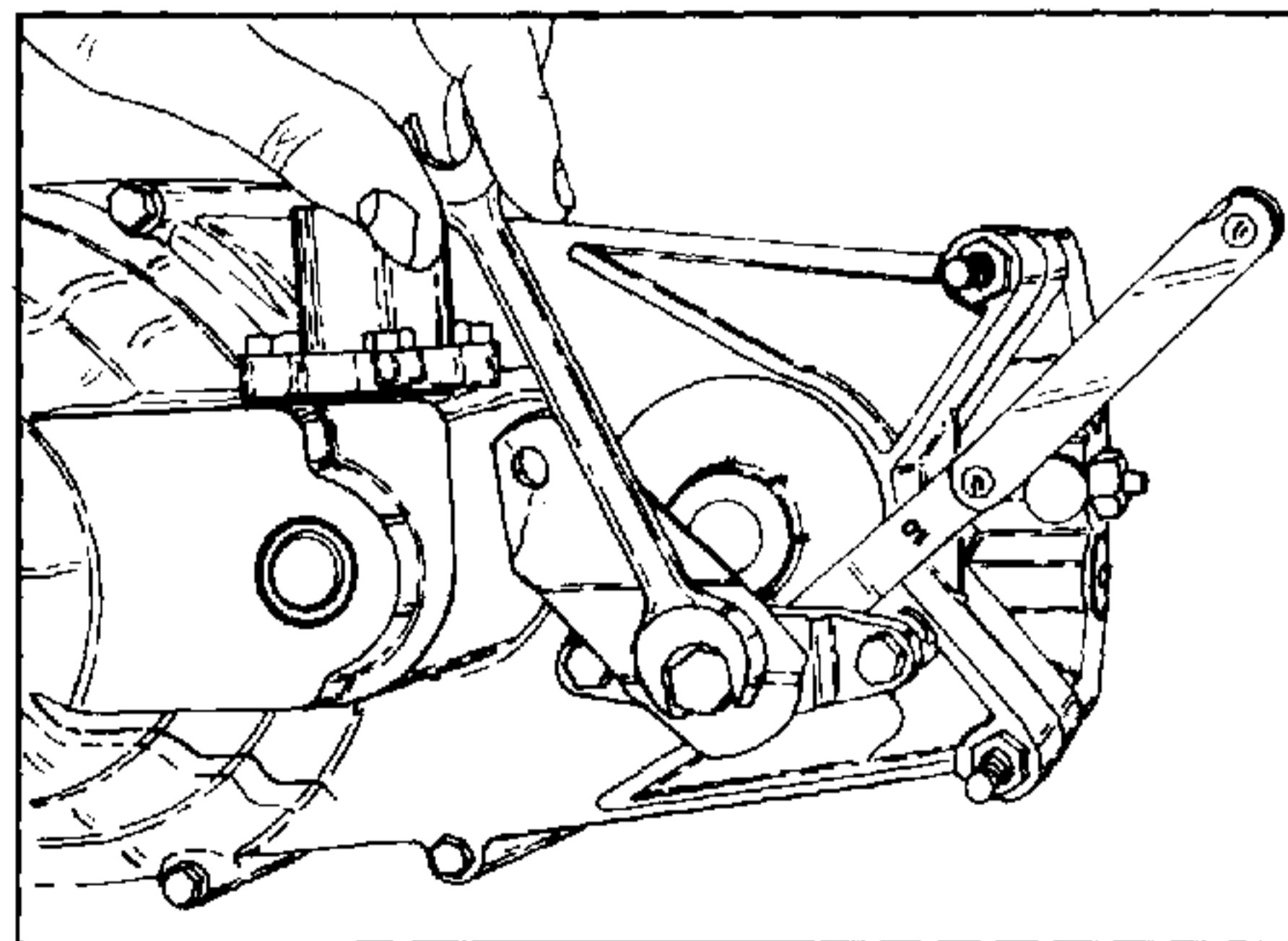
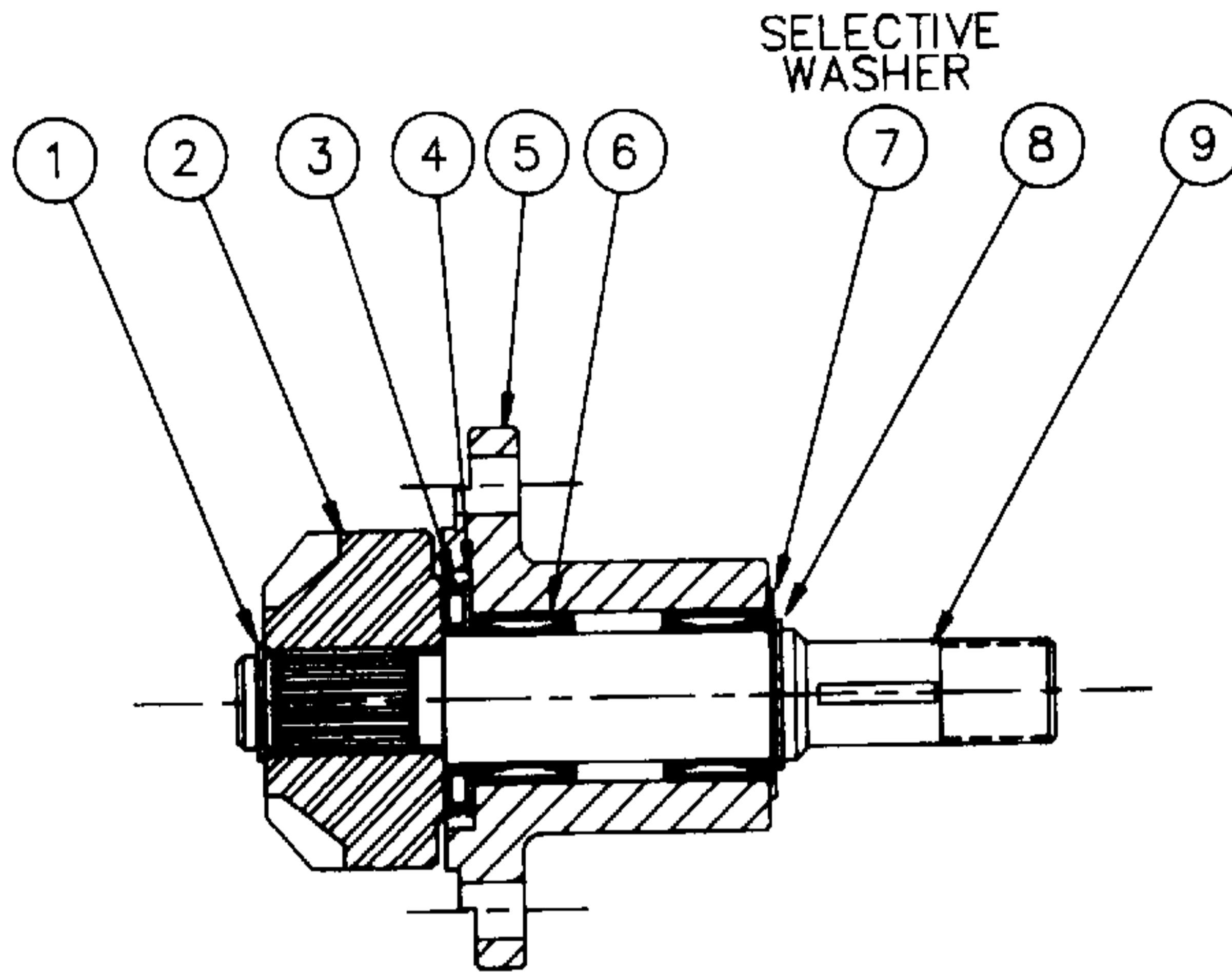

FIGURE 1.

INPUT ASSEMBLY

Section 3



- 1 RET. RING 5100-43
- 2 DRIVE PINION
- 3 THRUST BEARING
- 4 THRUST RACE
- 5 INPUT BEARING HSG.
- 6 NEEDLE BEARING
- 7 FL. WASHER 5/8 ID
- 8 RET. RING 5100-62
- 9 INPUT SHAFT

SECTION 3 DAMAGED INPUT ASSEMBLY

- 3.00 If any input assembly component appears malfunctioning, removal can be done without transaxle disassembly.
- 3.10 Important! When servicing input assembly, clean area thoroughly with a degreaser-cleaner before removing assembly.
- 3.11 To detach assembly remove (3) bolts from input housing and then lightly tap assembly to free from pilot mounting surface.
- 3.12 Wash input assembly and inspect for damage.
- 3.20 Hand turn input shaft. If it feels rough or is hard to turn, bearings must be replaced.
- 3.21 Remove retaining ring from top of assembly. Slide pinion and shaft out of housing.
- 3.22 With a suitable arbor push both needle bearings through housing as shown in figure 2.
- 3.23 To reinstall new bearings, use an arbor to press bearings into both ends of housing. (Note: Bearings must be flush).
- 3.24 Check needle bearing running surface on input shaft. If this area appears gulled, flaked, or grooved then replacement is a must.

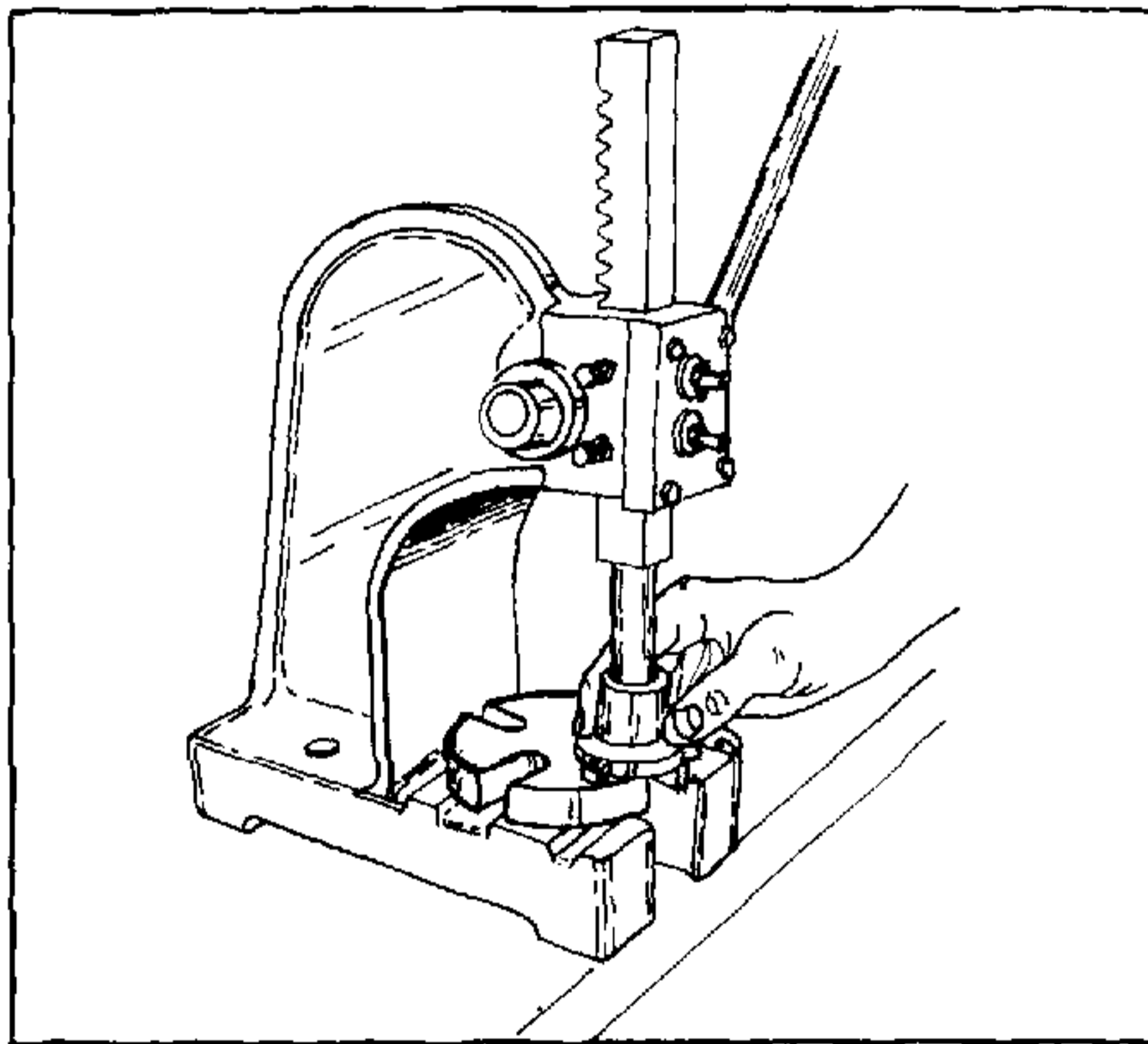

FIGURE 2.

- 3.30 Remove small retaining ring from input shaft. Slide pinion from shaft and inspect for damaged gear teeth or internal splines.
- 3.31 Replace needle thrust bearing and thrust races if they appear gulled, flaked, or grooved.
- 3.32 If pinion is found to be damaged it is likely that the driven pinion is also damaged.

- 3.33 To check driven pinion for damage, look into input opening on transaxle. (Figure 3) Rotate drive shaft on hydro, figure 4 to view teeth of driven pinion. To replace pinion, see section 5.30 DAMAGED DRIVEN PINION.

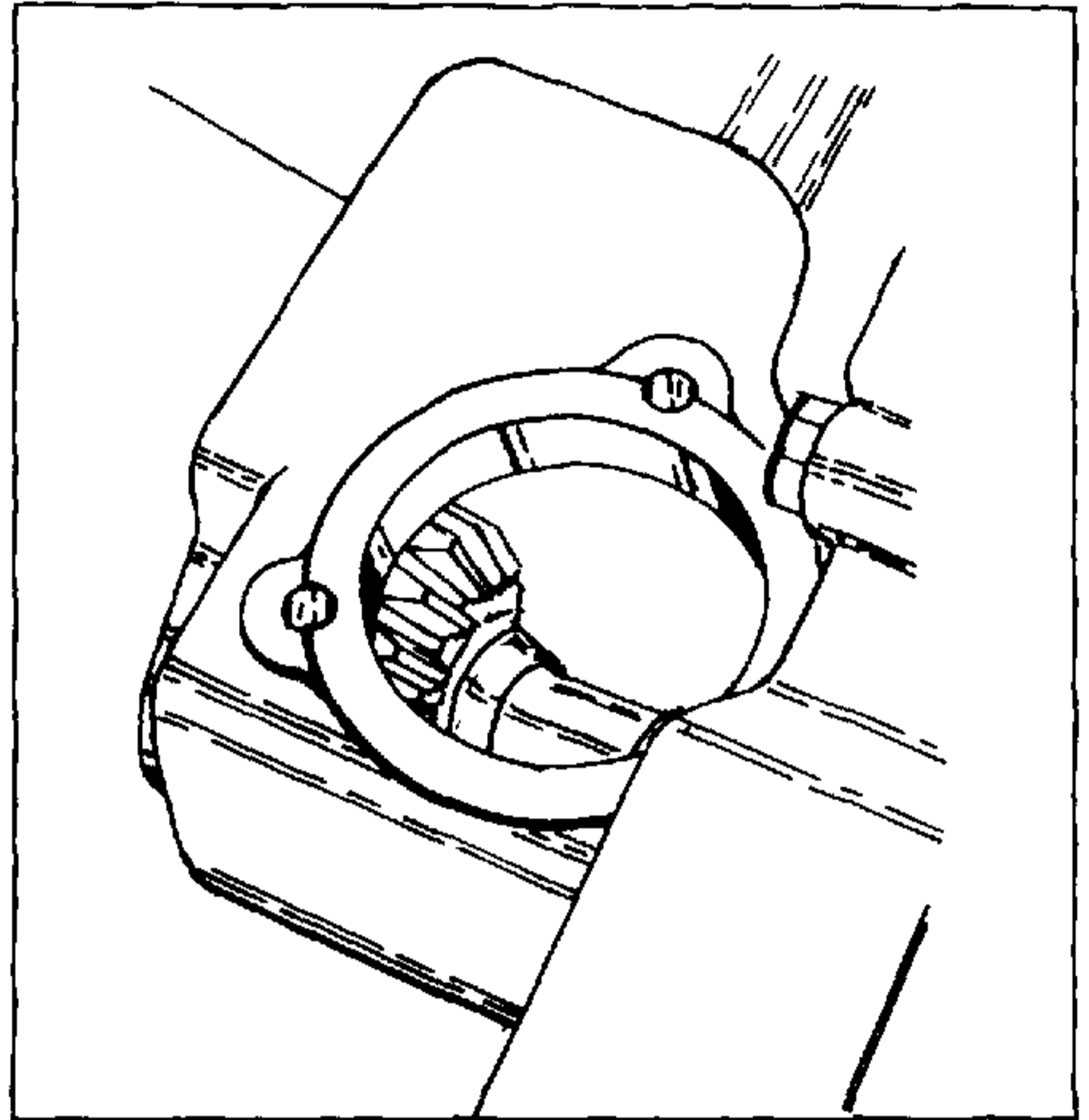

FIGURE 3.

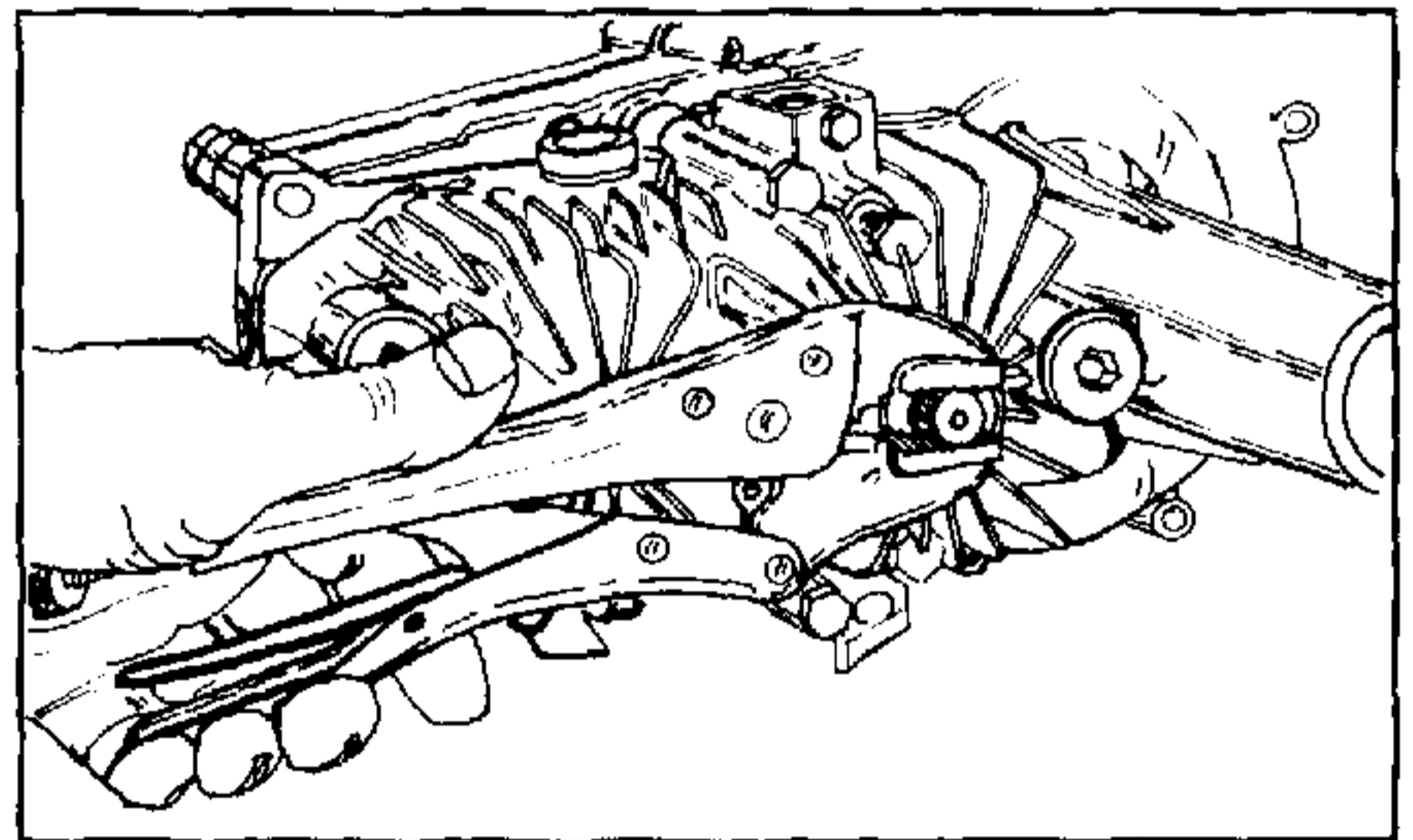

FIGURE 4.

- 3.40 Reassemble in reverse order to disassemble. (Note: Before putting shaft into housing pack grease between (2) needle bearings.
- 3.50 The washers under the retaining ring are factory selected. If any component has been replaced a new washer or washers must be selected. Check with feeler gauge for a maximum .010 end play. Figure 5.

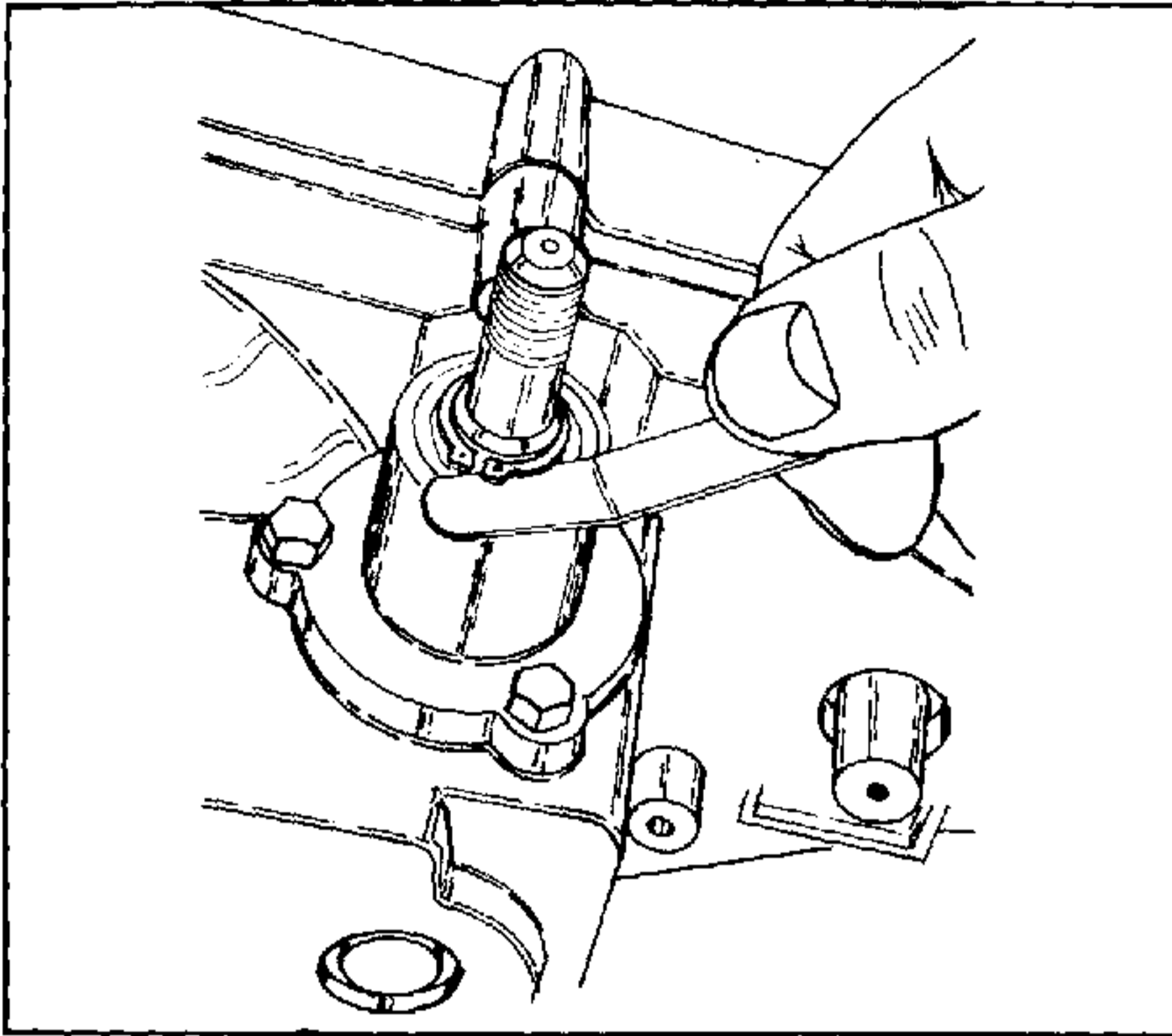

FIGURE 5.

- 3.60 Before remounting input assembly wipe both mounting surfaces clean and repack 5 ounces of grease on driven pinion.
- 3.70 To assure proper backlash on input bevel gears the following test must be completed.
- 3.71 Bolt down input assembly and torque to 80-120 Inch/LBS. Do not use locktite #242 until backlash check has been completed.
- 3.72 Remove retaining ring and washers from input shaft.
- 3.73 Clamp transaxle into vise using rags or hardwood blocks to prevent distortion of housings. (Only if transaxle has been removed from tractor.)
- 3.74 Set up indicator to the top of the input shaft. Figure 6.

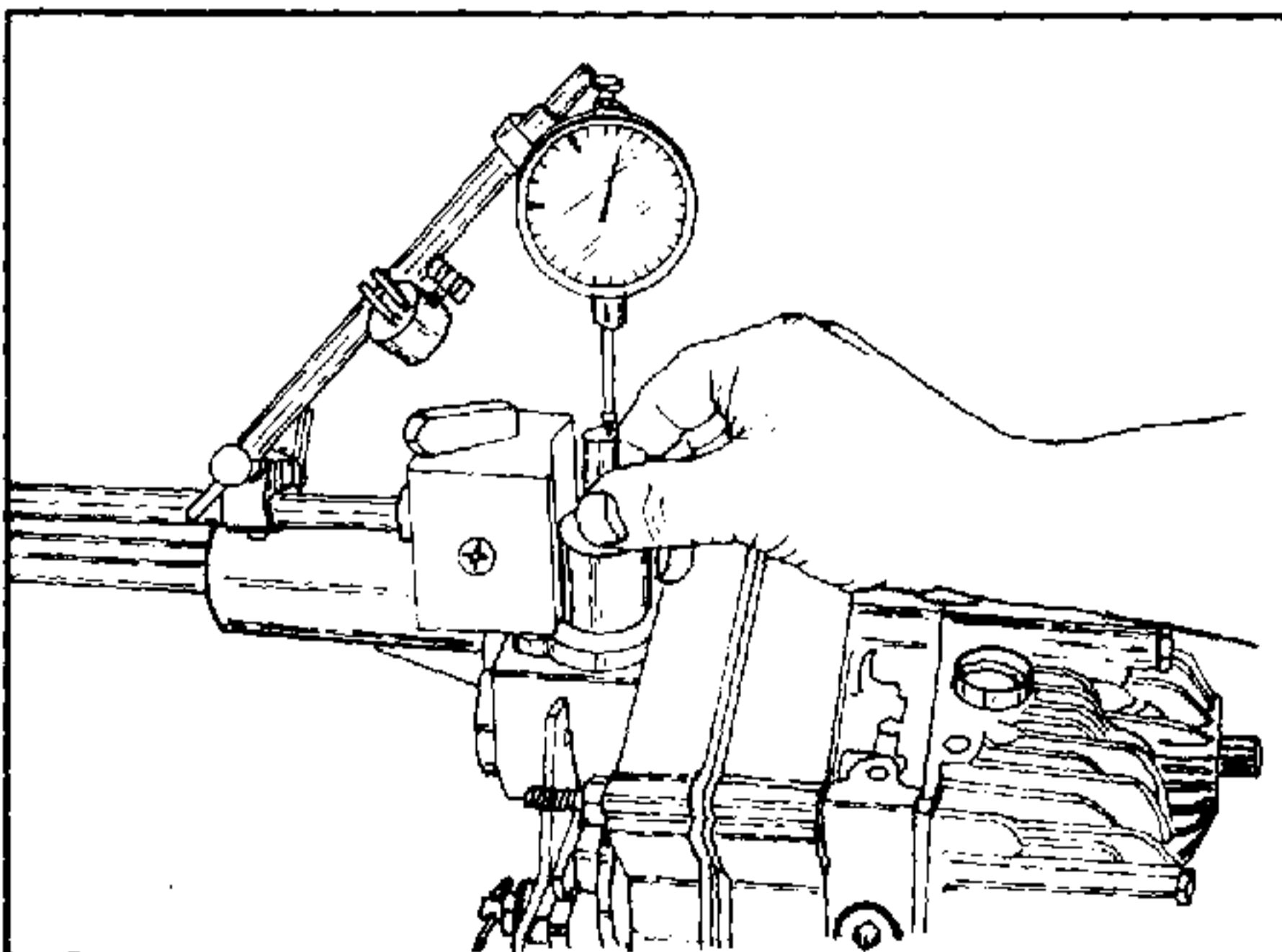

FIGURE 6.

- 3.75 Push input shaft down until bottoming out on mating gear, for "0" backlash condition. Set indicator dial to "0".
- 3.76 Pull input shaft up until stopped. Read indicator scale and record.
- 3.77 The total reading must be at minimum .012 to .030 maximum travel to meet the recommended backlash.
- 3.78 To decrease backlash insert a 5/8 ID heat treated washer between input pinion and thrust race.
- 3.79 When final readings fall within acceptable limits, remove (3) mounting bolts and reinstall using locktite #242, retorqued to 80-120 Inch/LBS.
- 3.80 Assemble (1) or more selective washers and retaining ring. (IMPORTANT! Recheck .010 maximum end play, section 3.50.)

SECTION 4 HYDRO TRANSMISSION REMOVAL

- 4.00 Repairs covered in this section may require removal of the transaxle from the tractor.
- 4.10 Remove (4) bolts securing hydro to axle. (For hydro repairs see Sundstrand Hydro Transmission manual.)
- 4.20 The hydro input and output shafts are coupled to the transaxle input/output shafts with (2) sets of couplings. To service either unit the couplings must be removed from the shaft splines.
- 4.21 Couplings are locktited in place and thus a puller is recommended. Figure 7. Tapping lightly or heating couplings may be necessary for removal.
- 4.22 Check coupling teeth and spline for wear. Replace if needed.

DIFFERENTIAL ASSEMBLY

Section 5.50

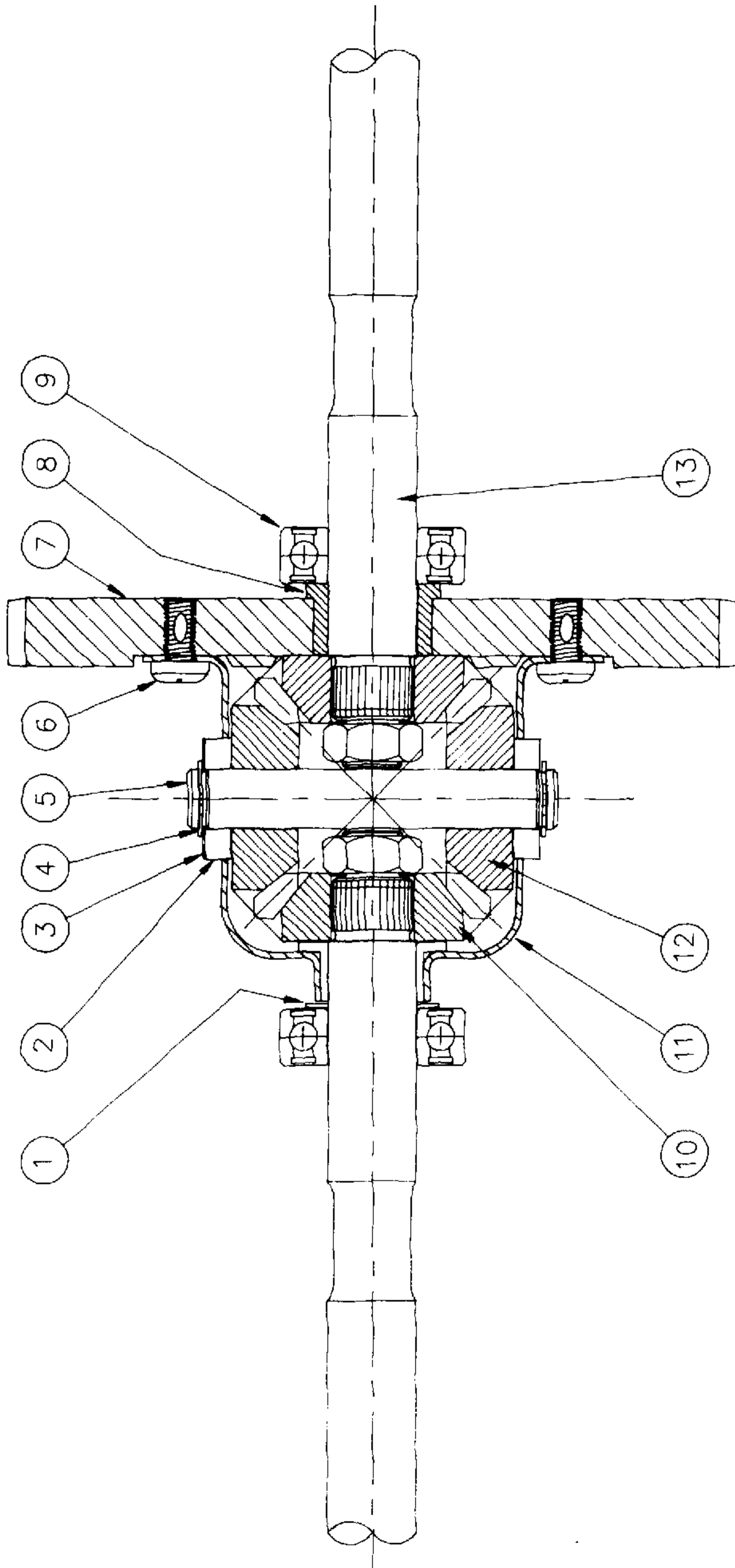

- | | |
|----|-----------------------------|
| 1 | FL. WASHER 3/4 ID |
| 2 | THRUST BEARING 1/2 ID |
| 3 | FL. WASHER 1/2 ID |
| 4 | RET. RING 5160-47 |
| 5 | CROSS SHAFT |
| 6 | PAN HD SCREW |
| 7 | FINAL DRIVE GEAR (72) |
| 8 | FLANGE BEARING 3/4 ID |
| 9 | BALL BEARING 3/4 ID x 40 MM |
| 10 | MITER GEAR SPLINED |
| 11 | DIFFERENTIAL HSG. ASSY. |
| 12 | MITER GEAR 1/2 ID |
| 13 | AXLE SHAFT |

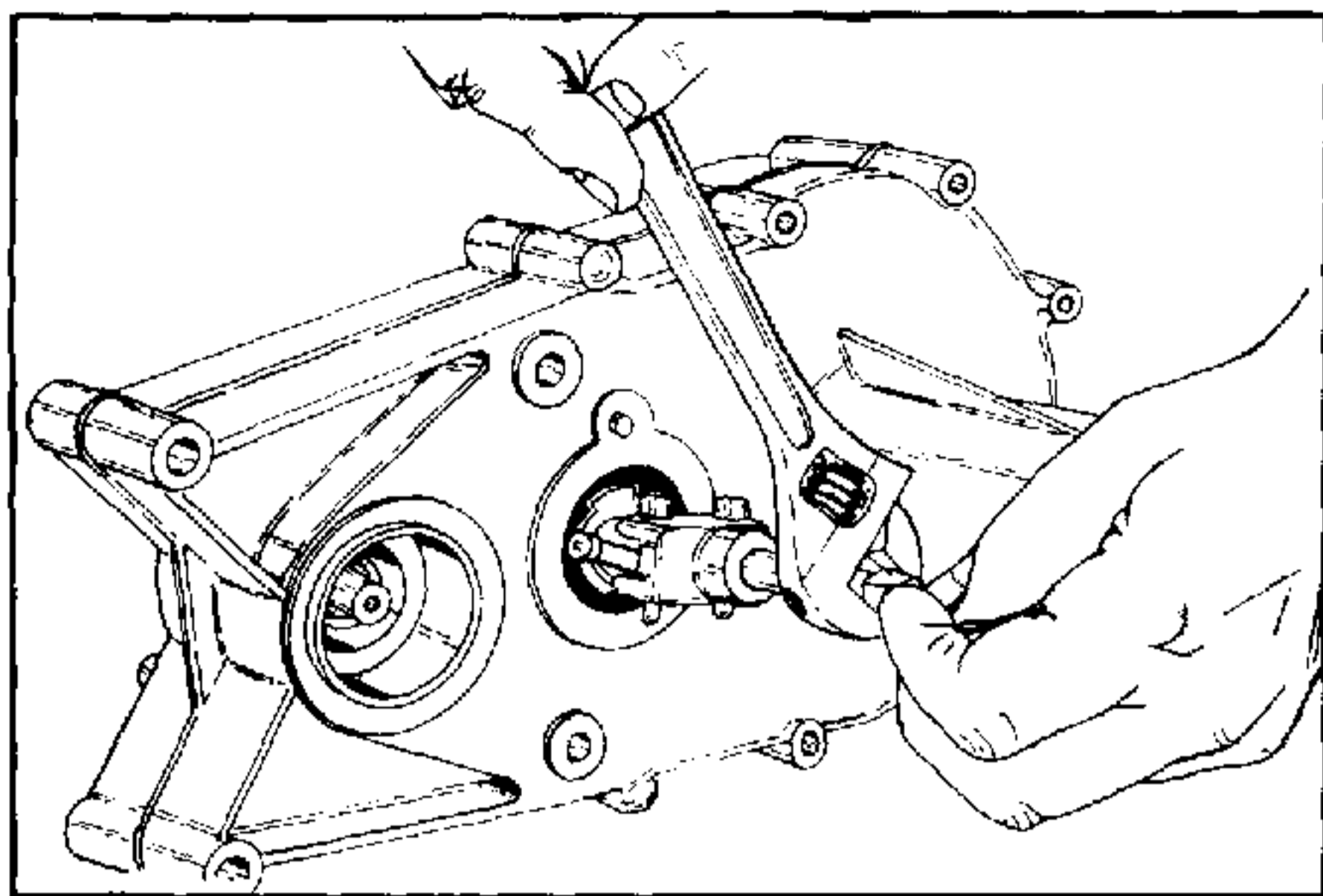

FIGURE 7.

SECTION 5 TRANSAXLE REPAIR

5.00 If the previous checklist, (Section 1) did not remedy the problem, and the hydro transmission is functioning, then an internal malfunction can be assumed.

5.10 Remove transaxle from tractor and follow tear-down procedure section 3.11

5.11 Remove (8) self-tapping screws.

Note! Before pulling housing halves apart, axle shaft ends must be free of rust and nicks for ease of disassembly. Do not try to force halves apart before preparation. Figure 8.

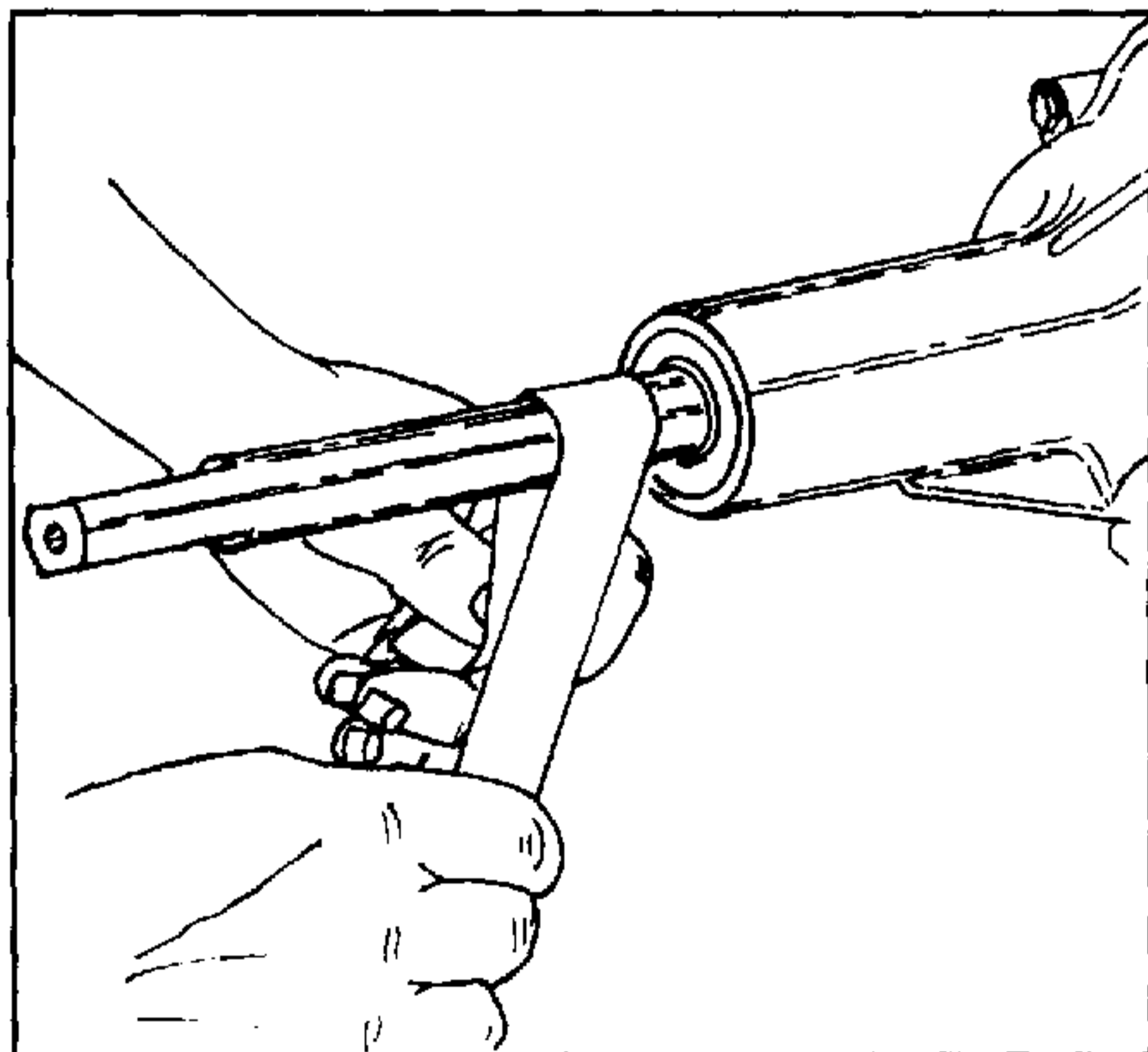

FIGURE 8.

5.12 Carefully pry halves apart in areas shown in figure 9. Caution! Do not nick mating surfaces. Tap lightly on drive shaft with a brass hammer as needed.

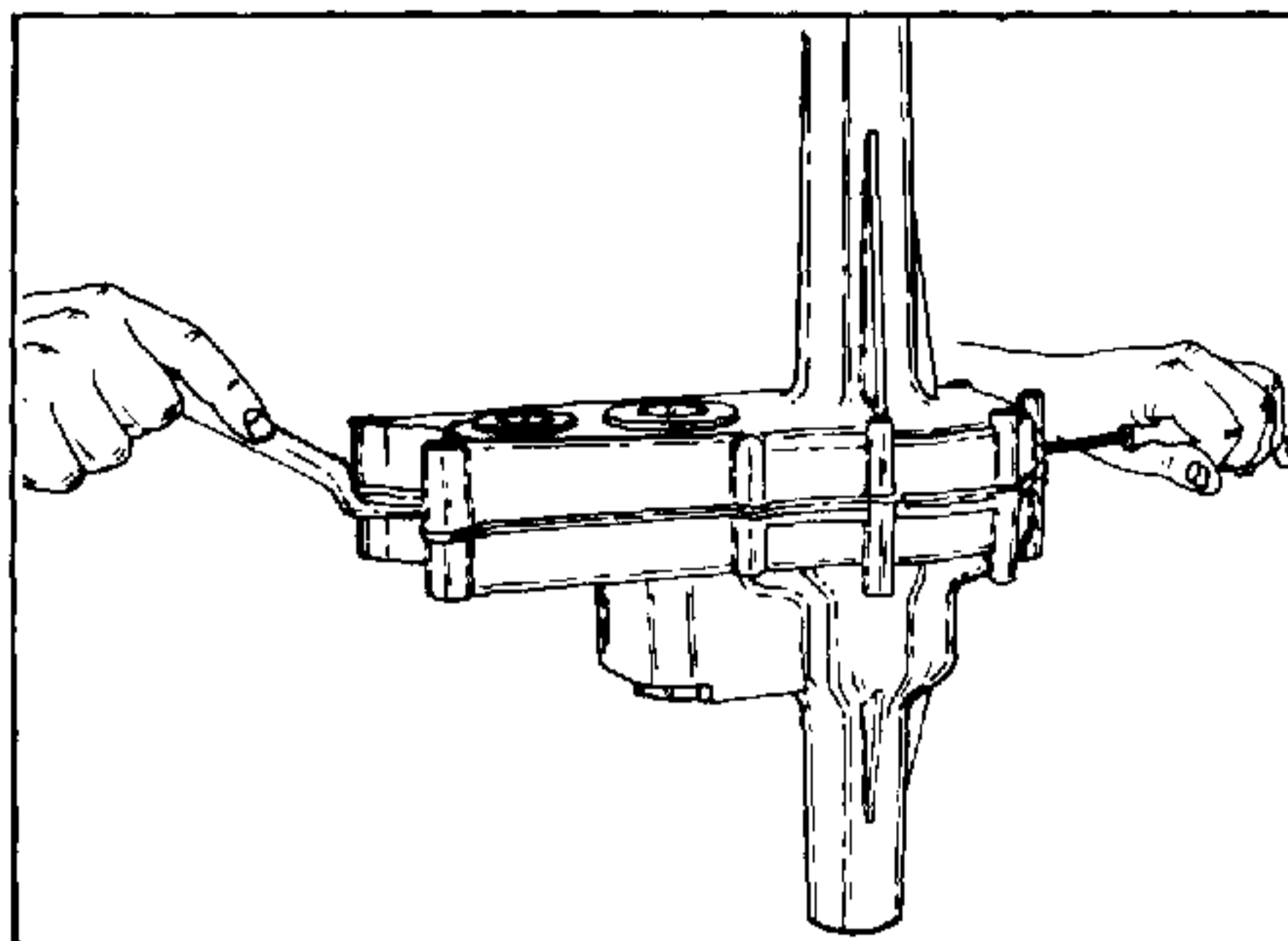

FIGURE 9.

5.20 Use puller on drive shaft assembly to remove ball bearing from shaft. Figure 10.

5.21 Pull reduction gear from drive shaft and inspect for damage.

5.22 If reduction gear teeth are found to be broken then mating gears must also be checked. See section for pinion or final drive replacement.

5.23 Check needle bearings for damage. If reduction gear is being replaced, then it would be wise to replace both needle bearings.

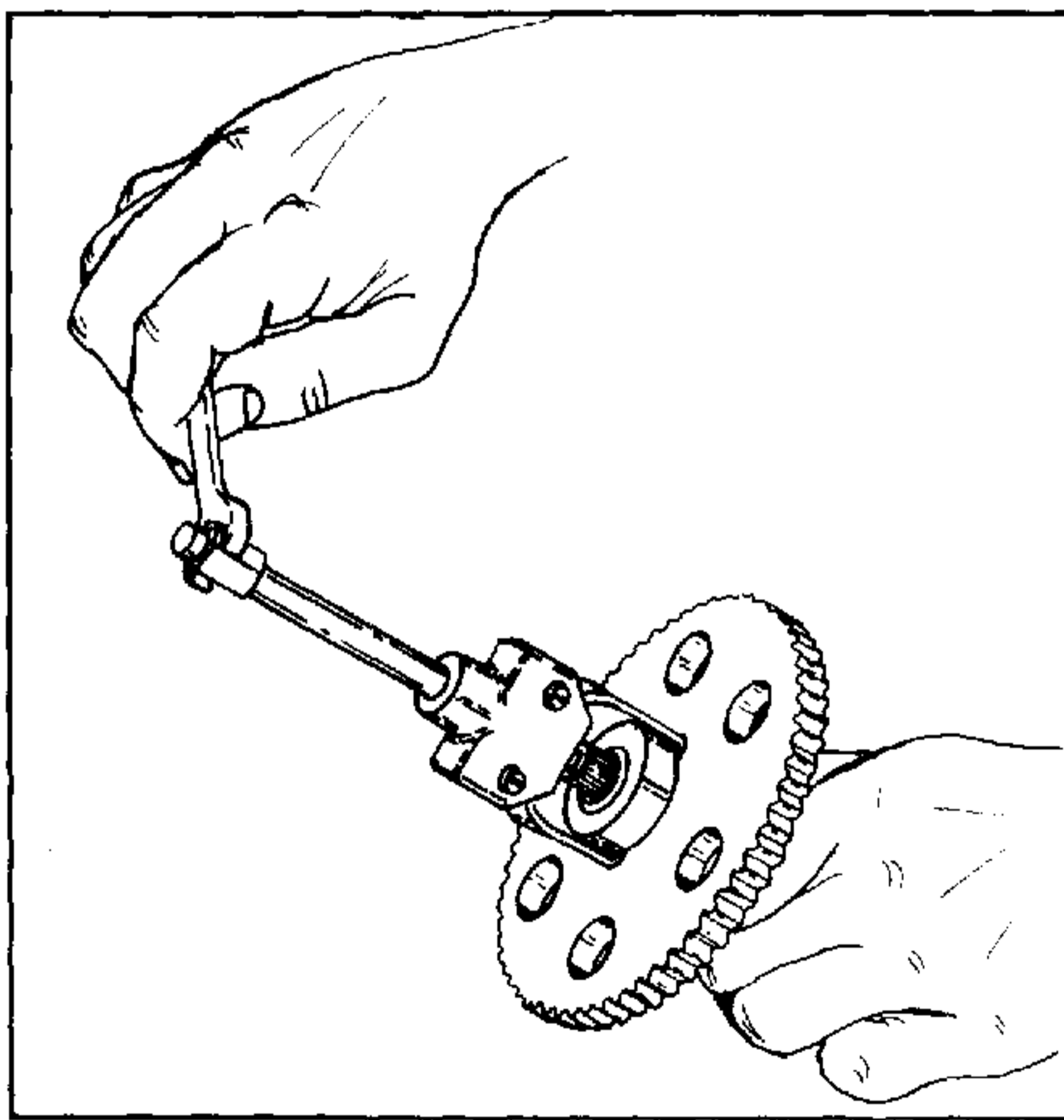

FIGURE 10.

5.24 Note: There are (2) different length bearings in the reduction gear. These bearings must be reinstalled in the same order as disassembly. Figure 11.

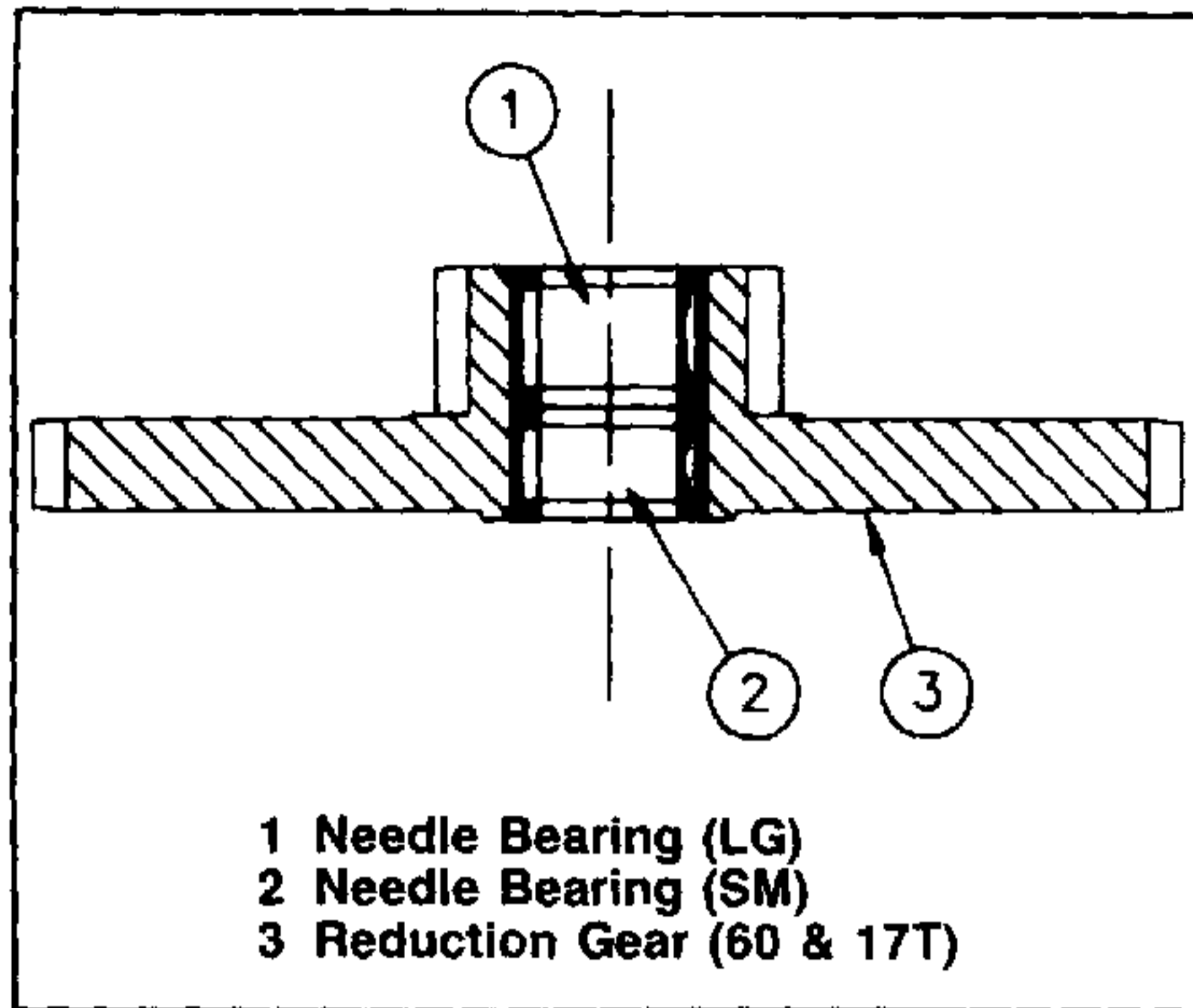

FIGURE 11.

5.25 Check needle bearing running surface on drive shaft. If this area appears gulled, flaked, or grooved then, replacement of shaft and needle bearing is a must.

DAMAGED DRIVEN PINION

5.30 Follow disassembly procedure section 5 TRANSAXLE REPAIR.

5.31 Use a puller or brass hammer to tap drive shaft through driven pinion. Inspect spline on shaft for damage, replace as needed.

DAMAGED PINION SHAFT

5.40 To remove pinion shaft the brake yoke assembly and brake disc must be removed. (See section 1.20 - 1.30.)

5.41 Pull key from shaft and slide pinion shaft through ball bearing.

FINAL DRIVE/DIFFERENTIAL

5.50 After removal from housing assembly. Disassembly of differential is done by removing (4) screws from final drive gear.

5.51 Slide longer axle shaft through gear and check bronze flange bearing for wear. Replace as needed using an arbor or press.

5.52 Remove retaining ring from cross shaft and slide shaft through bevel gears. Check gear teeth for damage, replace as needed.

5.53 Slide shorter axle shaft through differential housing and check bronze flange bearing for wear. If bearing is found to be damaged, **DO NOT ATTEMPT TO REPLACE FLANGE BEARING.** Bearing must be replaced as a sub assembly with differential housing.

5.54 Differential housing must be checked for damage. If holes for cross shaft bearing appear elongated, housing is distorted, or anti-rotational ears are damaged. Housing sub assembly with flange bearing must be replaced.

5.55 If miter gear on axle shafts are found to be broken refer to section 5.61 - 5.62.

5.56 Reassemble differential in reverse order and use (1) ounce of lubricant on miter gears.
(NOTE: DO NOT REUSE DIFFERENTIAL HOUSING SCREWS WITHOUT USING LOCKTITE #242.)

AXLE SHAFT REPLACEMENT

5.60 Follow transaxle disassembly sections 5.10 - 5.22 and differential disassembly sections 5.50 - 5.54.

5.61 Remove nut securing miter gear to shaft. Slide gear from spline and inspect for damage.

5.62 Reassemble shaft and splined miter gear with a new nut or use locktite #242. Torque to 40-55 Ft./LBS.

5.63 Reassemble differential (see section 5.56).

SECTION 6 HOUSING CRACKED OR BROKEN

6.00 See disassembly procedure 5.10 - 5.22.

6.10 When a transaxle housing is being replaced it is also recommended that new ball bearings be installed. See section 7.30 for bearing reinstallation. (IMPORTANT! In the right hand housing [housing on which brake is mounted] are (3) different type bearings. Use damaged housing as a reference for reassembly.)

STRIPPED THREADS

6.20 If any threads are stripped and replacement housings are not available, then housing repair can be done by the following steps. (WARNING! Transaxle must be disassembled before attempting repair.)

6.21 To repair any of the (3) 1/4-20 threads at the input housing mount, use a #R1185-4 1/4-20 x .375 HeliCoil.

6.22 Bolts securing both housing halves are self-tapping bolts and must be torqued to 80-120 Inch/LBS. Over torquing bolts will strip out threads. If any of these bolts are stripped, drill (using 1/4" drill) through boss damaged. Reinstall a 1/4-20 bolt and nut reaching through both housings. Use locktite #242 on nut and torque to 80-120 Inch/LBS.

6.22 **WARNING! DO NOT LEAVE DRILL SHAVINGS IN TRANSAXLE.**

SECTION 7 DAMAGED BALL BEARINGS

7.00 See disassembly procedure 5.10 - 5.22.

7.10 If bearings feel like balls are catching, are hard to turn, or very loose, replacement is a must.

7.20 Remove bearings from damaged housing using an impact puller (figure 12) or tapping bearings out using the correct diameter rod as shown in figure 13.

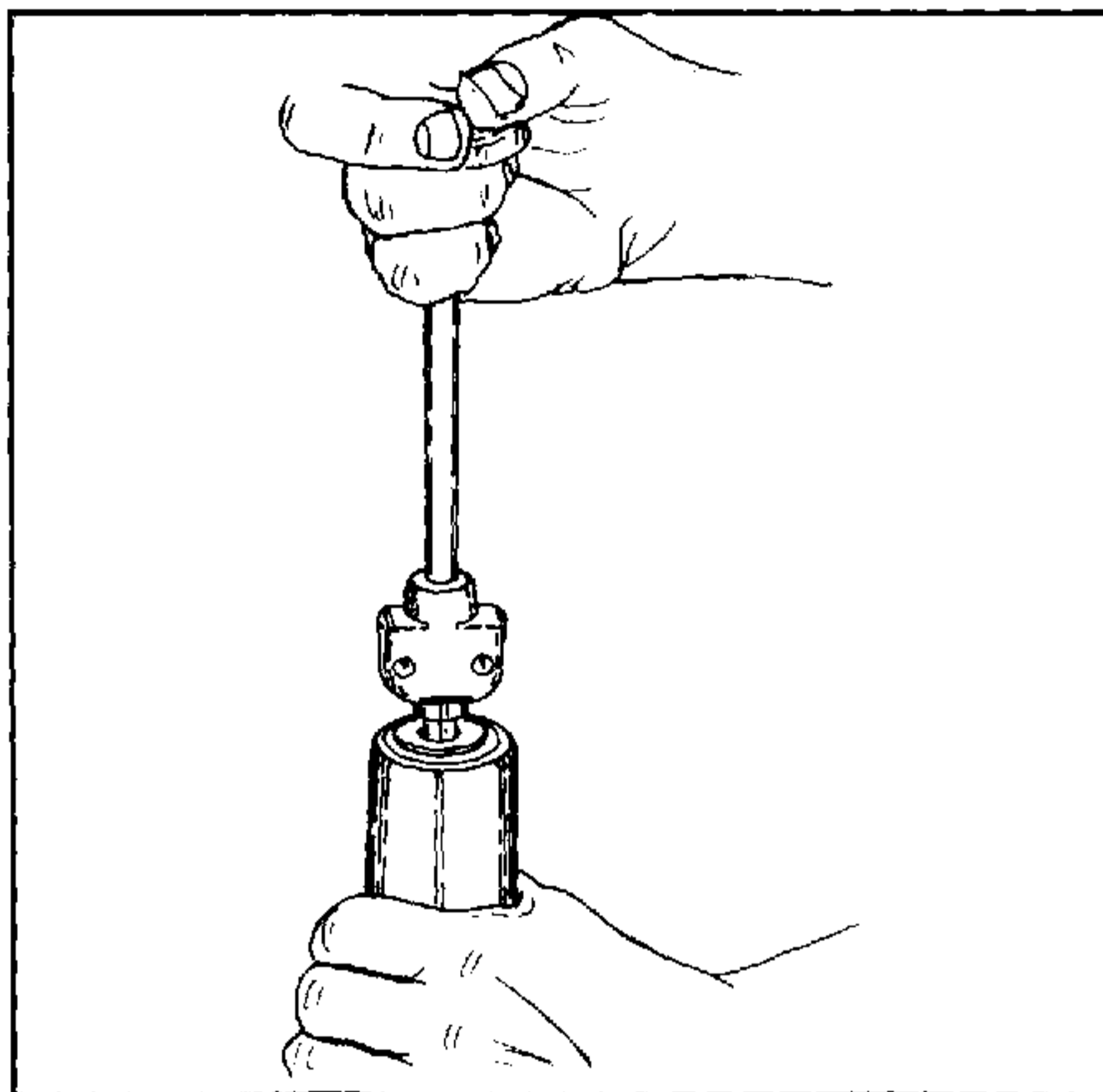

FIGURE 12.

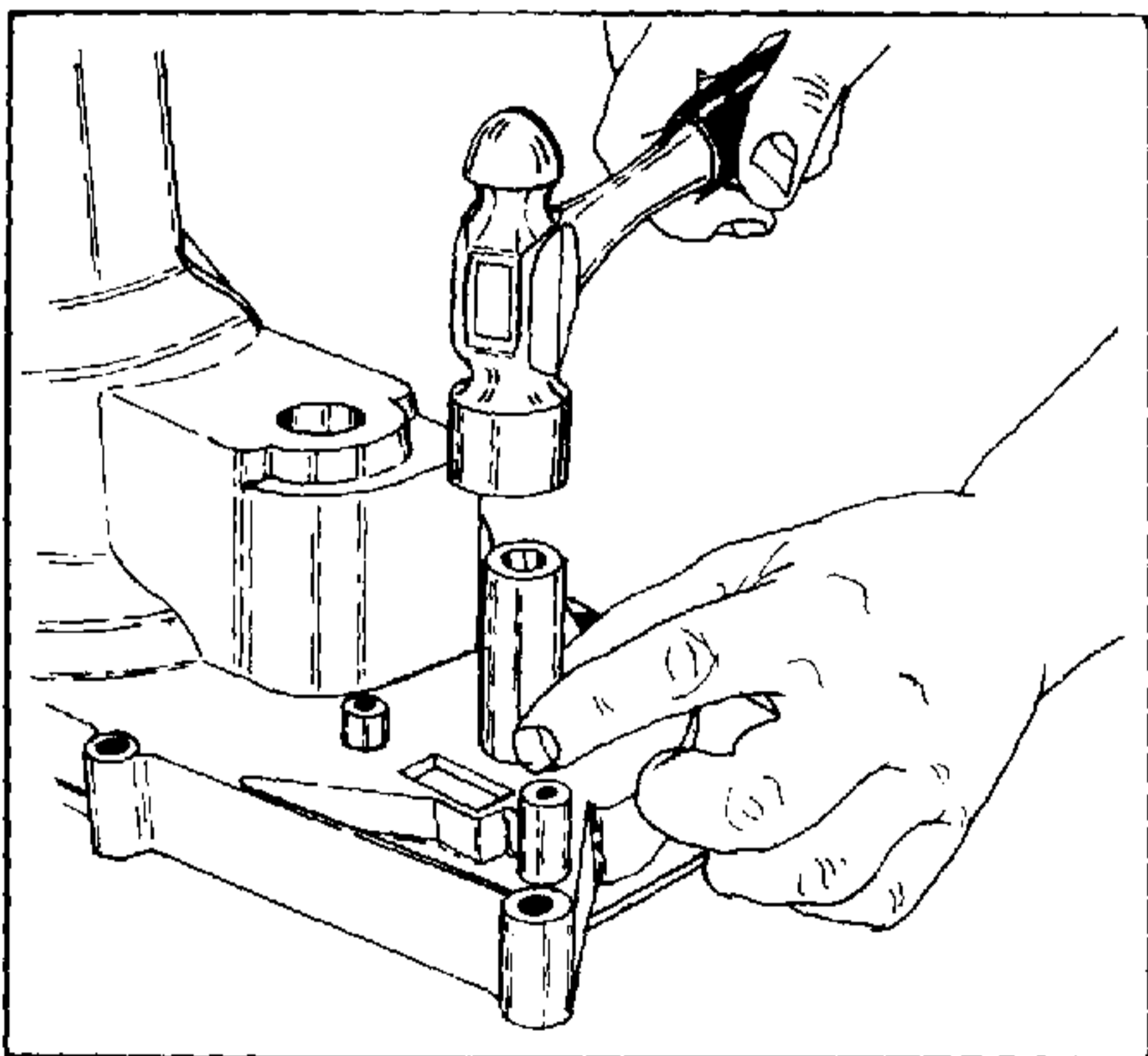

FIGURE 13.

7.30 Reinstall bearings with Loctite Bearing Mount/B adhesive sealant and press in place using a suitable arbor.

7.31 Wipe bearings clean of excess loctite.

SECTION 8 TRANSAXLE REASSEMBLY

8.00 Slide differential/axle assembly into right hand housing. (Housing on which brake is mounted.) Clamp axle gently in vise as shown in figure 14.

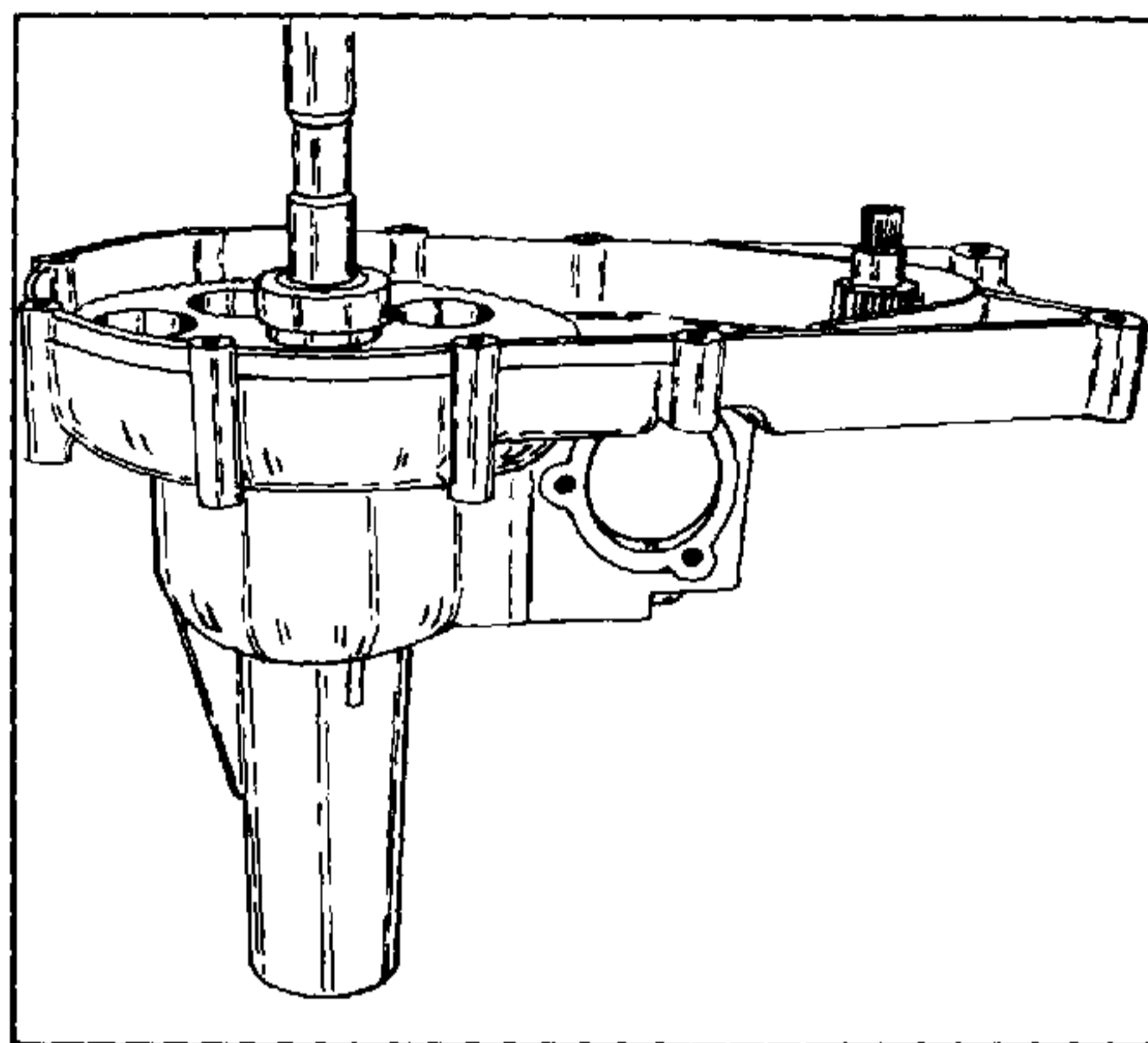

FIGURE 14.

8.10 Insert keyed end of pinion shaft into bearing.

8.11 Take drive shaft and press splined end into bearing until driven pinion is seated against bearing. Figure 15.

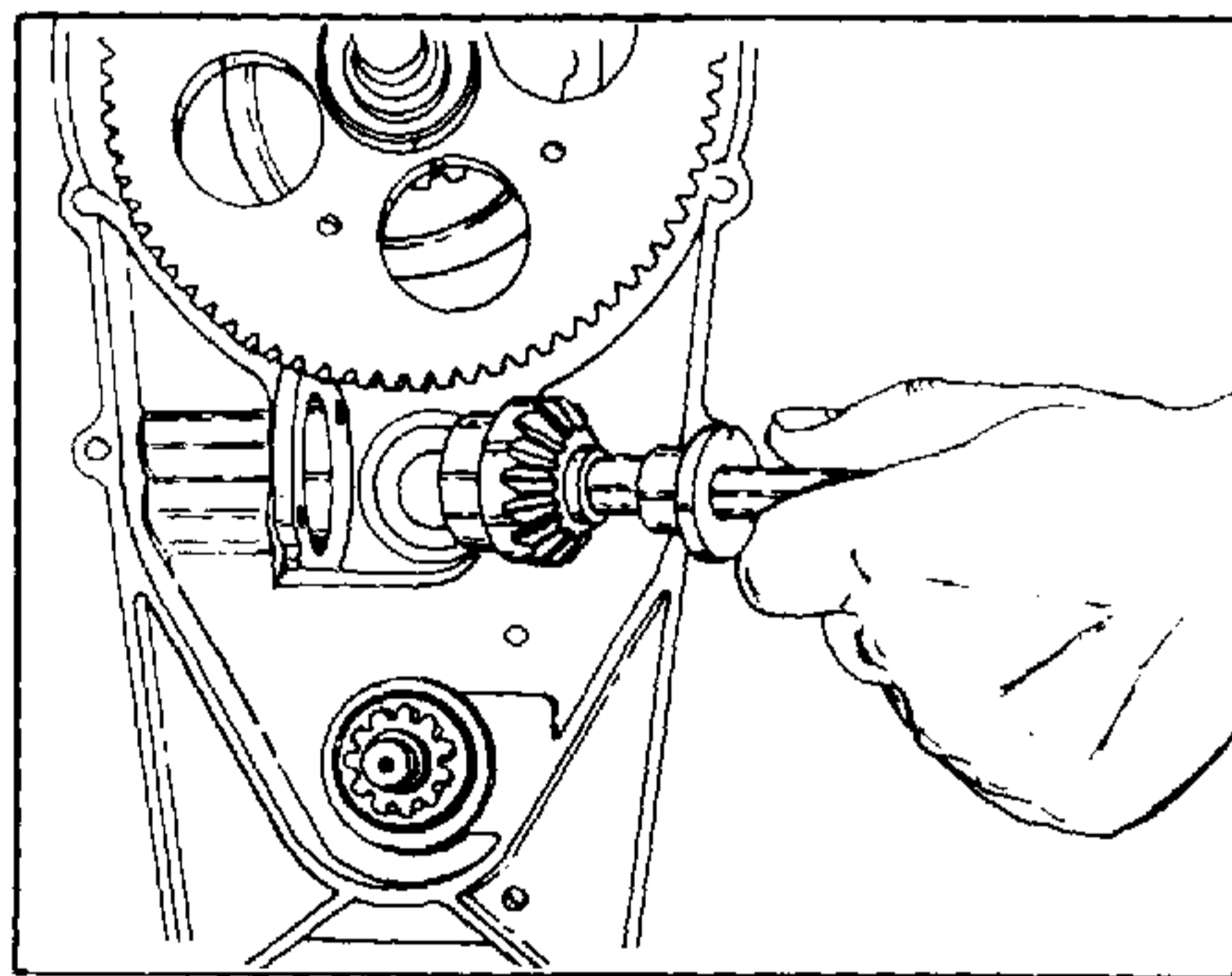

FIGURE 15.

8.12 Install .060 thrust race, needle thrust bearing, and .030 thrust race onto drive shaft, carefully lubricating each component.

8.13 Lubricate bearings in reduction gear. Carefully slip reduction gear on drive shaft rotating gear somewhat to align gear teeth.

8.20 The washer between the reduction gear and ball bearing of the other housing is selective to ensure proper clearances. Use the following test for selecting a correct washer.

8.21 Use a parallel bar across housing. Figure 16.

8.22 With a feeler gauge, pingages or stack of washers, measure the distance between the parallel bar and the reduction gear face. Figure 16.

8.23 Subtract .019 and .010 minimum clearance from dimension in section 8.22.

EXAMPLE:

	.059	Distance to parallel bar.
-	.019	Fixed dimension
-	.010	Minimum Clearance
	<hr/>	
	.030	Washer size

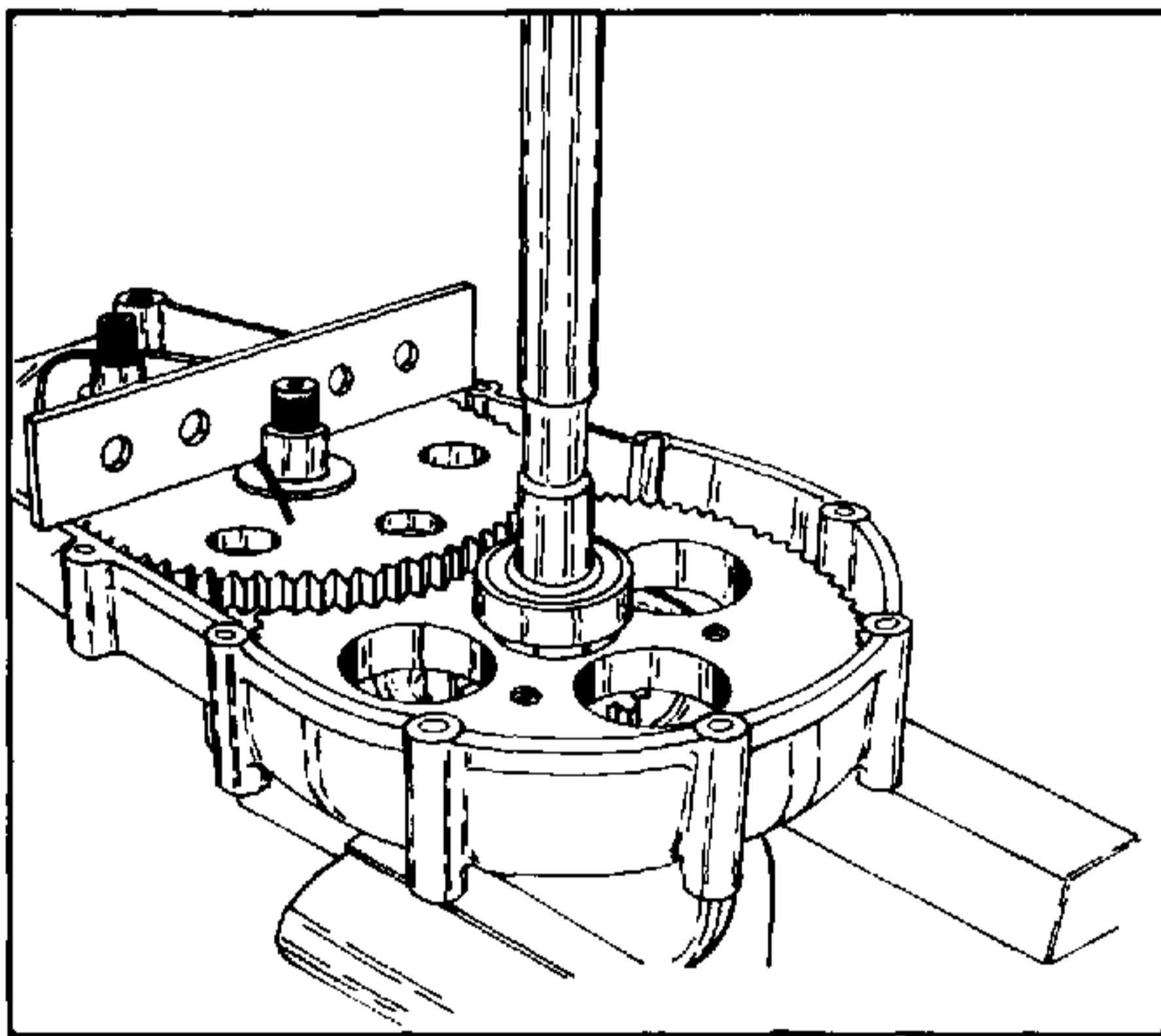

FIGURE 16.

8.30 Use 10 ounces of Durina-O type grease over gears.

8.31 Slide housing over axle shaft and pull housings together with (8) self-tapping screws and torque to 80-120 Inch/LBS.

8.40 Remove transaxle from vise.

8.41 Use a feeler gauge to check for .010 minimum clearance between thrust race and thrust bearing as shown in figure 17.

8.42 Turn axle shafts to make sure that gears rotate freely.

8.43 Pack 5 ounces of grease on driven pinion through input housing opening.

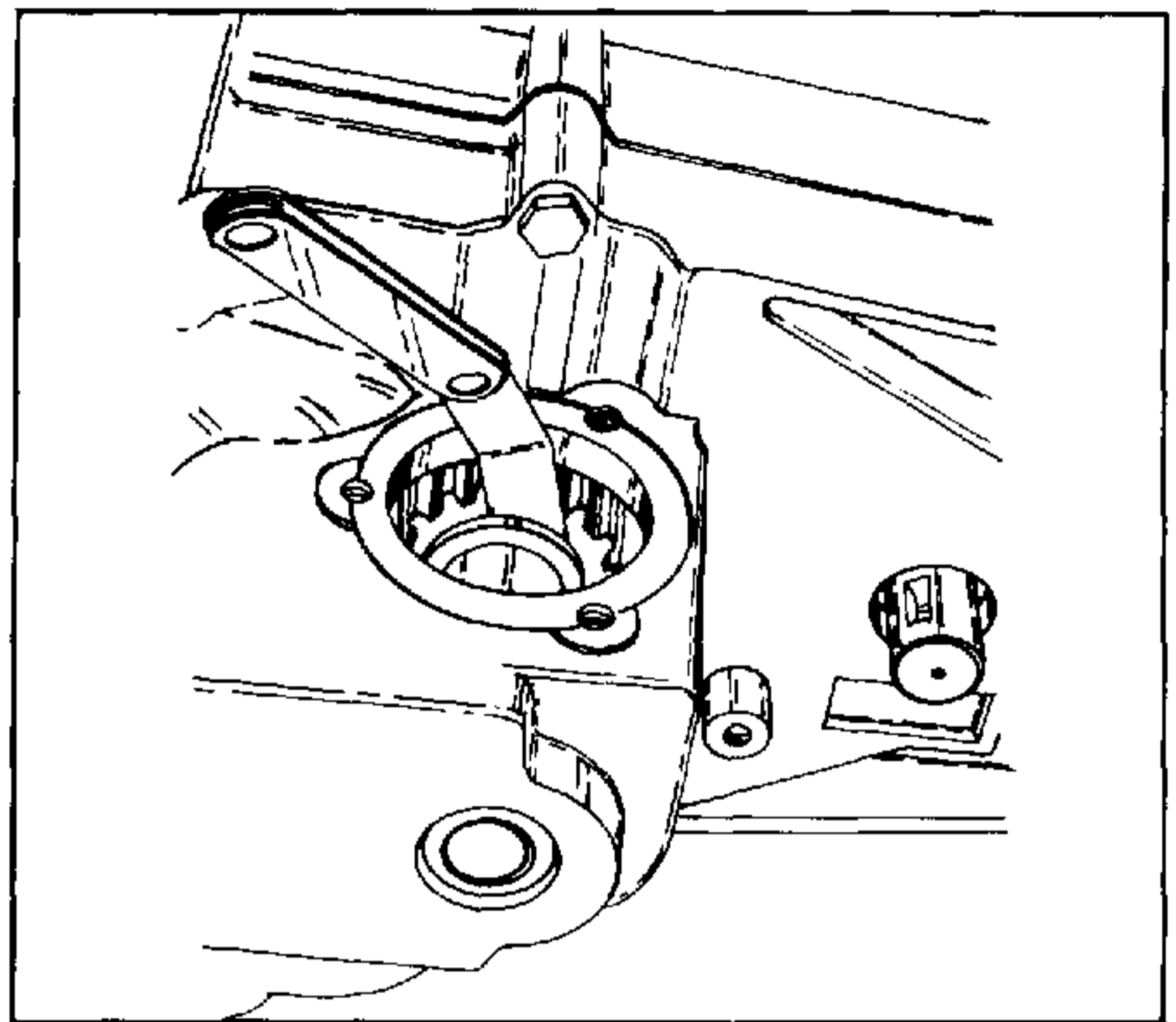

FIGURE 17.

8.50 Remount input housing assembly section 3.60.

8.51 Check backlash on input bevel gears section 3.70 - 3.80.

8.60 Assemble and mount brake. (see section 2.31 - 2.40.) for reassembly.

8.70 Reinstall couplings using locktite #609. Before operating unit allow locktite to dry for 24 hours.

8.80 Align the locating pin and pilot of the hydro with the housing. Pull hydro down with (4) mounting bolts and torque to 80-120 Inch/LBS. (Note: Use locktite #242 on mounting bolts.) (Fill hydro reservoir with oil per specifications.)

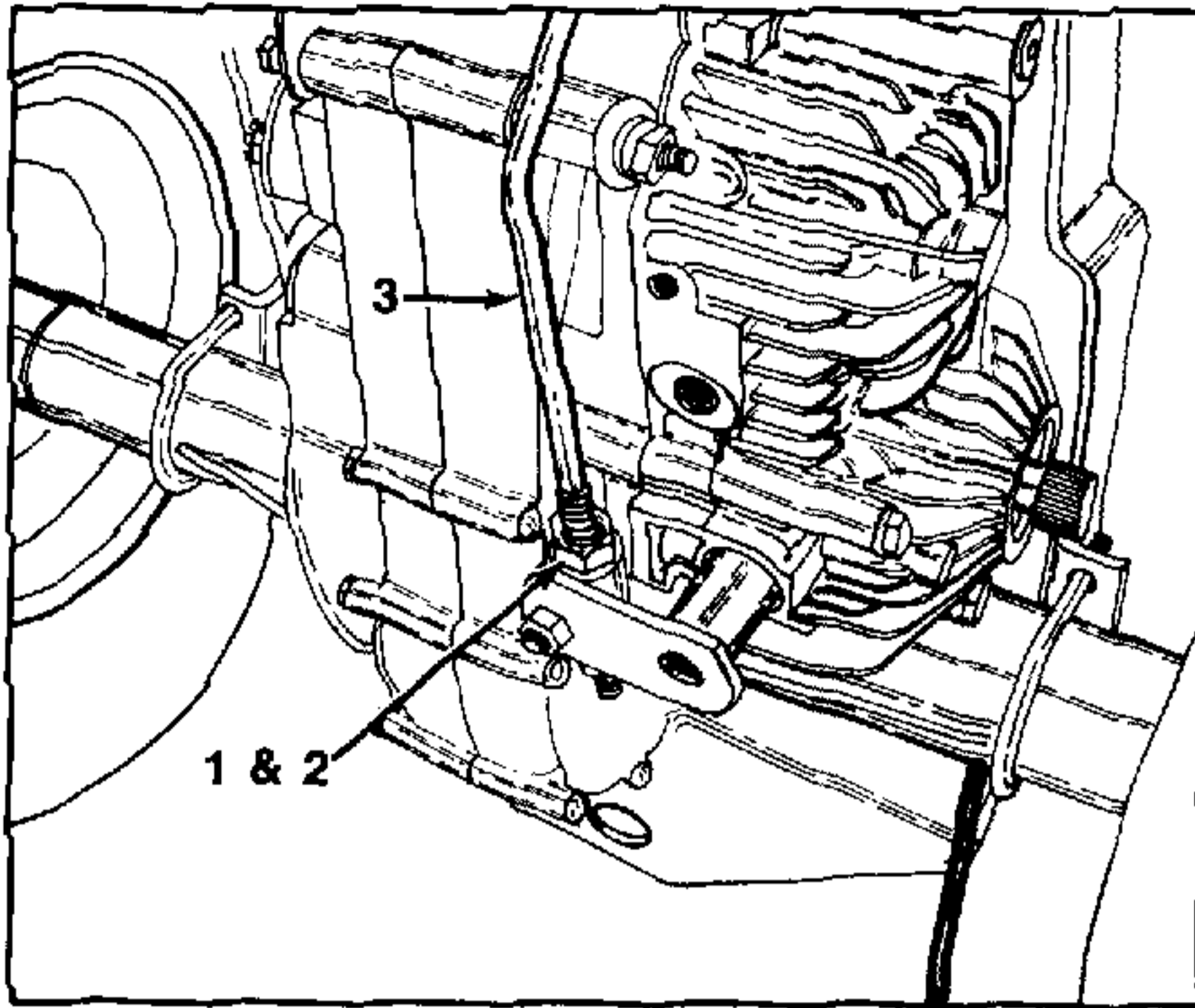

FIGURE 1.

HYDROSTATIC CONTROLS AND ADJUSTMENT (Models 1715 and 1720)

The following adjustment may be necessary for the hydrostatic adjustment rod if the tractor creeps forward or rearward while the speed control lever is in the neutral ("N") position. Refer to figures 1 and 2; while working from rear of tractor with unit off, proceed as follows:

1. If the tractor creeps forward, loosen the jam nut and turn the hex on the control assembly counter-clockwise until tractor creep is stopped. When correct adjustment is achieved, retighten jam nut.
2. If the tractor creeps rearward, loosen jam nut and turn the hex on the control assembly clockwise until tractor creep is stopped. When correct adjustment is achieved, retighten jam nut.

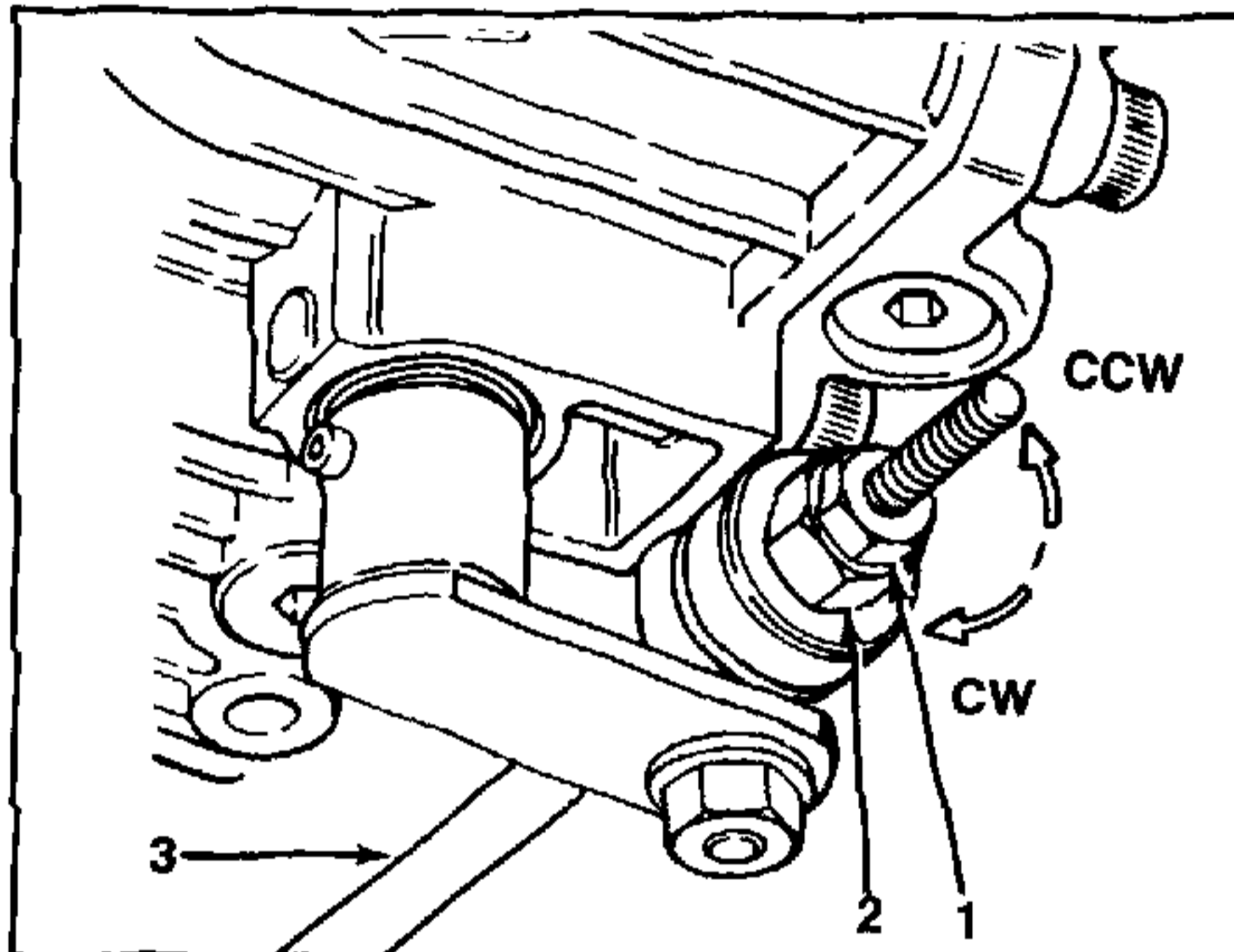

FIGURE 2.

ADJUSTING THE BRAKES (Models 1715 & 1720)

During normal operation on this machine, the brakes are subject to wear and will require periodic examination and adjustment.

To check brake adjustment, position the tractor on a level surface, place the gear shift lever in neutral ("N") position and perform the following checks:

1. Engage the brake pedal lock. If the unit can be pushed forward or rearward, the brake force must be increased.
2. Release the brake pedal lock. If the unit cannot be pushed forward or rearward, brake force must be decreased.

- | |
|--|
| <ol style="list-style-type: none"> 1. Jam Nut 2. Control Assembly 3. Adjustment Rod |
|--|

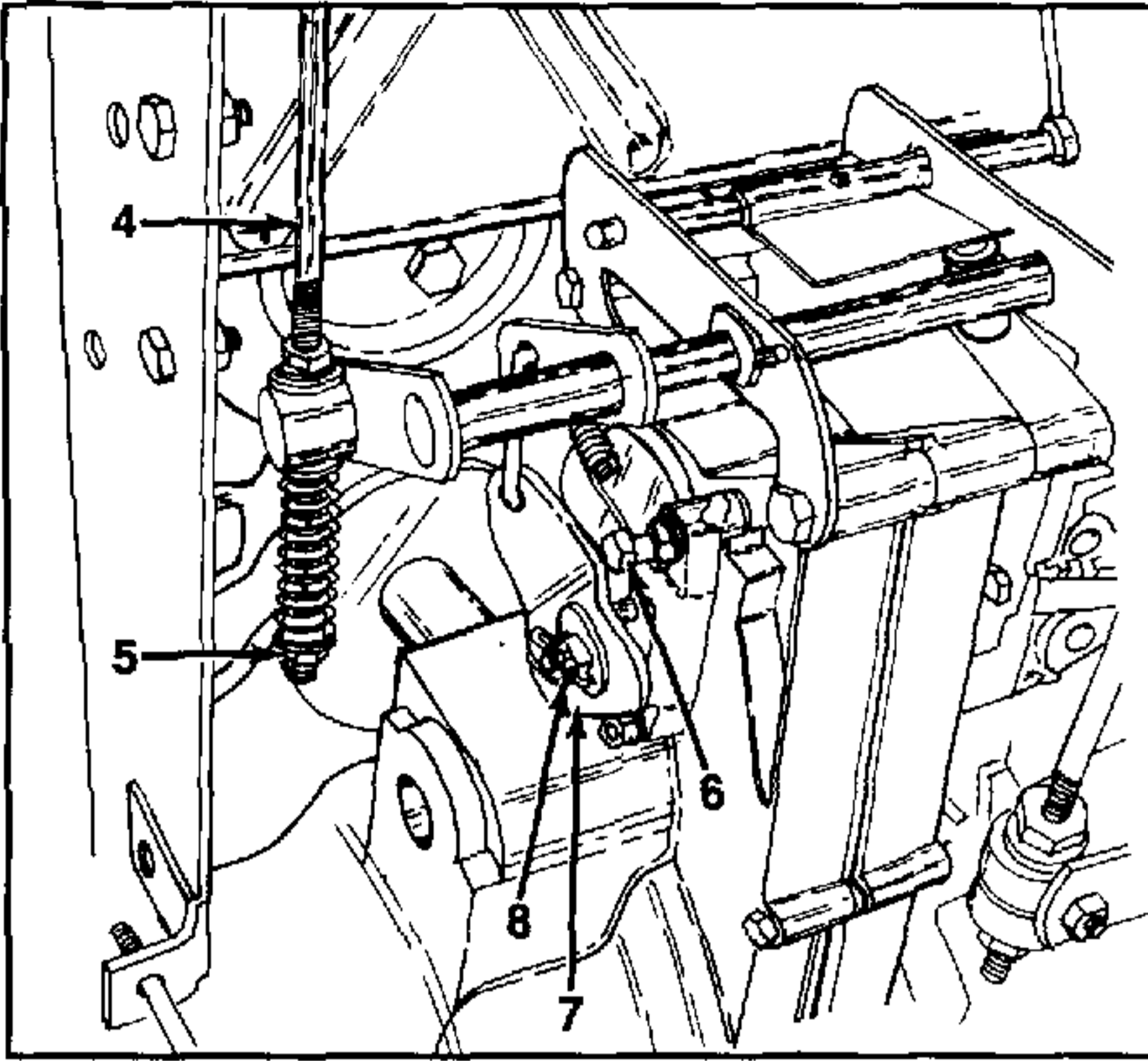

FIGURE 3.

Refer to the following instructions to increase or decrease brake force.

To increase brake force, refer to figure 3 and proceed as follows:

1. Place the tractor on a level surface, with the brake pedal lock disengaged.
2. Tighten the top lock nut 1/4 turn at a time until tractor free movement begins to bind. Then back off the top nut 1/4 turn.

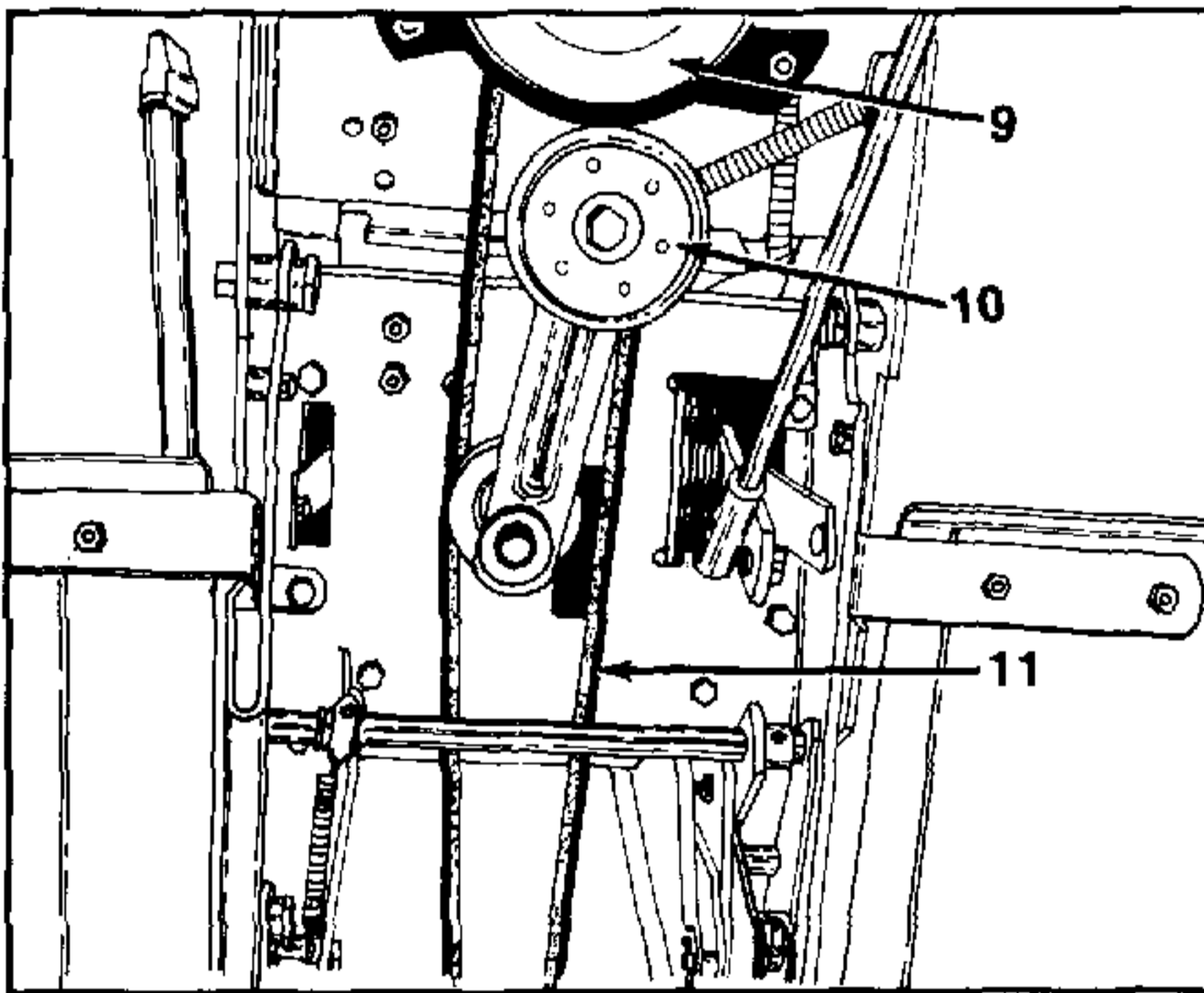

FIGURE 4.

**DRIVE BELT REPLACEMENT
(Models 1715 and 1720) (For Manual P.T.O. Drive Belt Models, Refer to page 2-85, Figure 6.)**

1. Remove the electric clutch (refer to section one pages 1-5 through 1-7).
2. Bring the belt around the spring loaded idler. See figure 4.

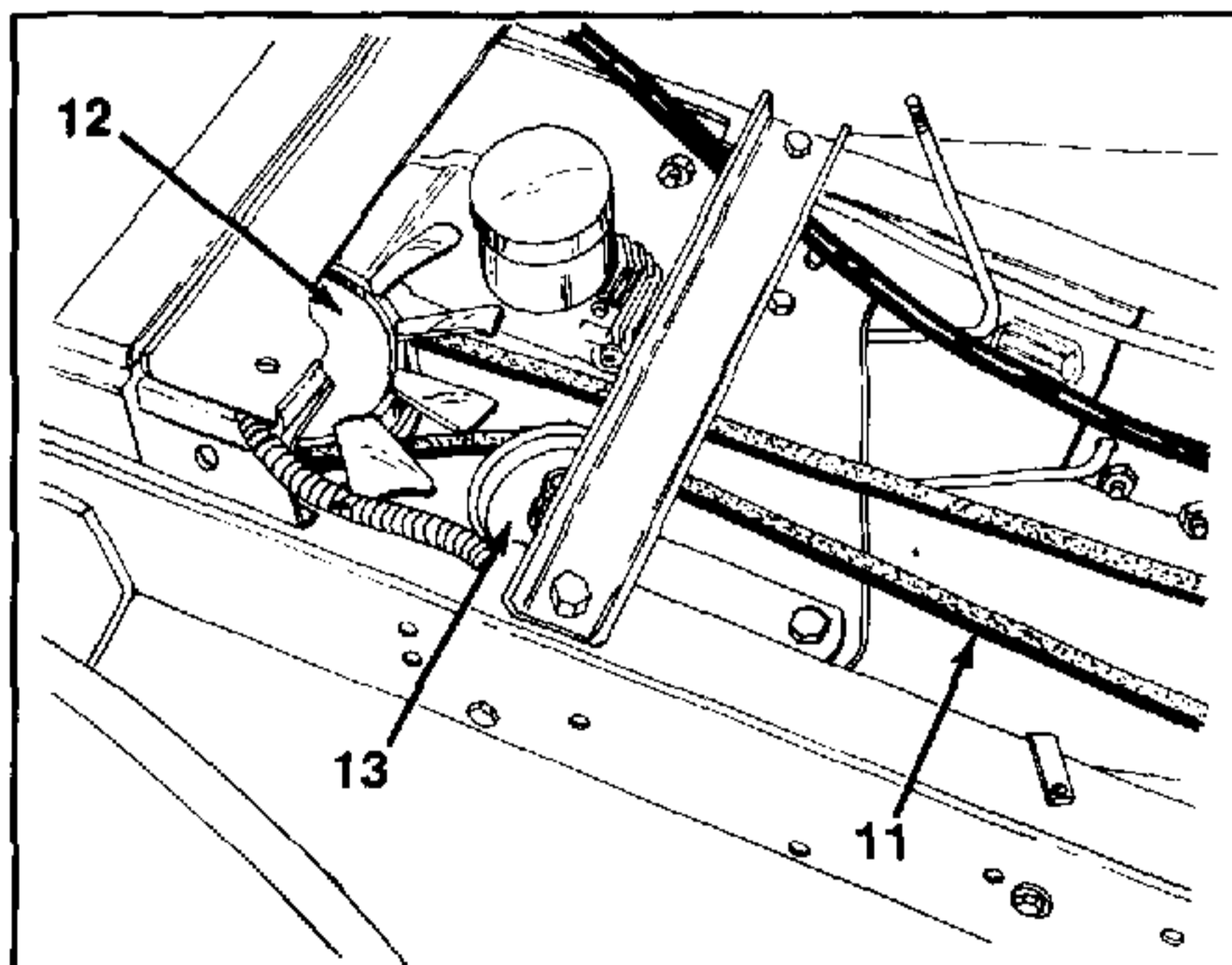

FIGURE 5.

3. Remove the fan assembly and slide the belt over the transaxle pulley and remove the idler. See figure 5. Then remove the belt.

- | |
|-------------------------|
| 4. Brake Rod |
| 5. Nut |
| 6. Stop Bolt |
| 7. Cam Lever |
| 8. Top Lock Nut |
| 9. Electric Clutch |
| 10. Spring Loaded Idler |
| 11. Drive Belt |
| 12. Fan Assembly |
| 13. Idler |

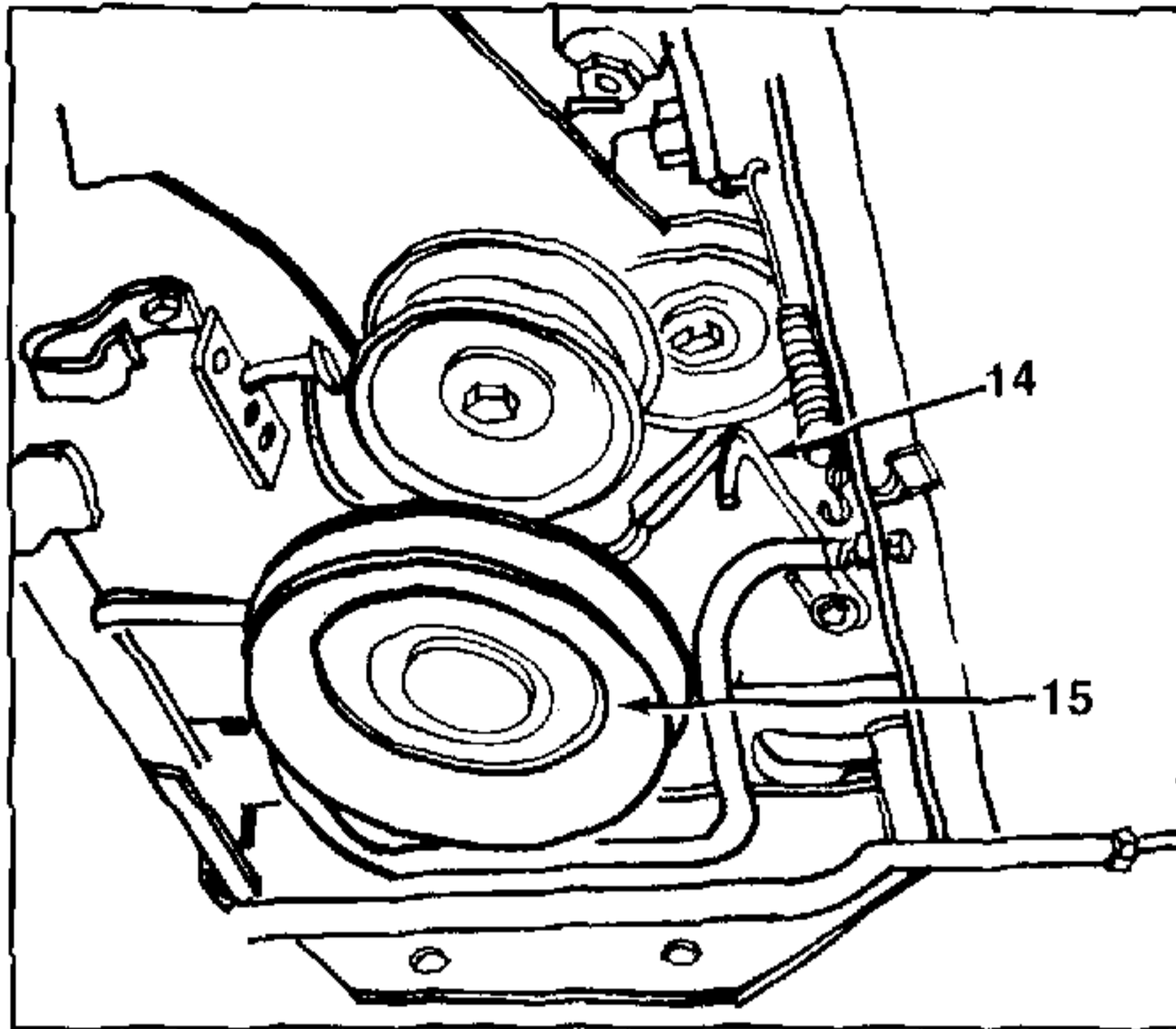

FIGURE 6.

DRIVE BELT REPLACEMENT FOR MANUAL P.T.O. MODELS

1. Loosen the hex bolt on the wire belt guard and pivot wire guard out of the way. See figure 6.

- | |
|--|
| 14 Wire Belt Guard
15 Engine Pulley |
|--|

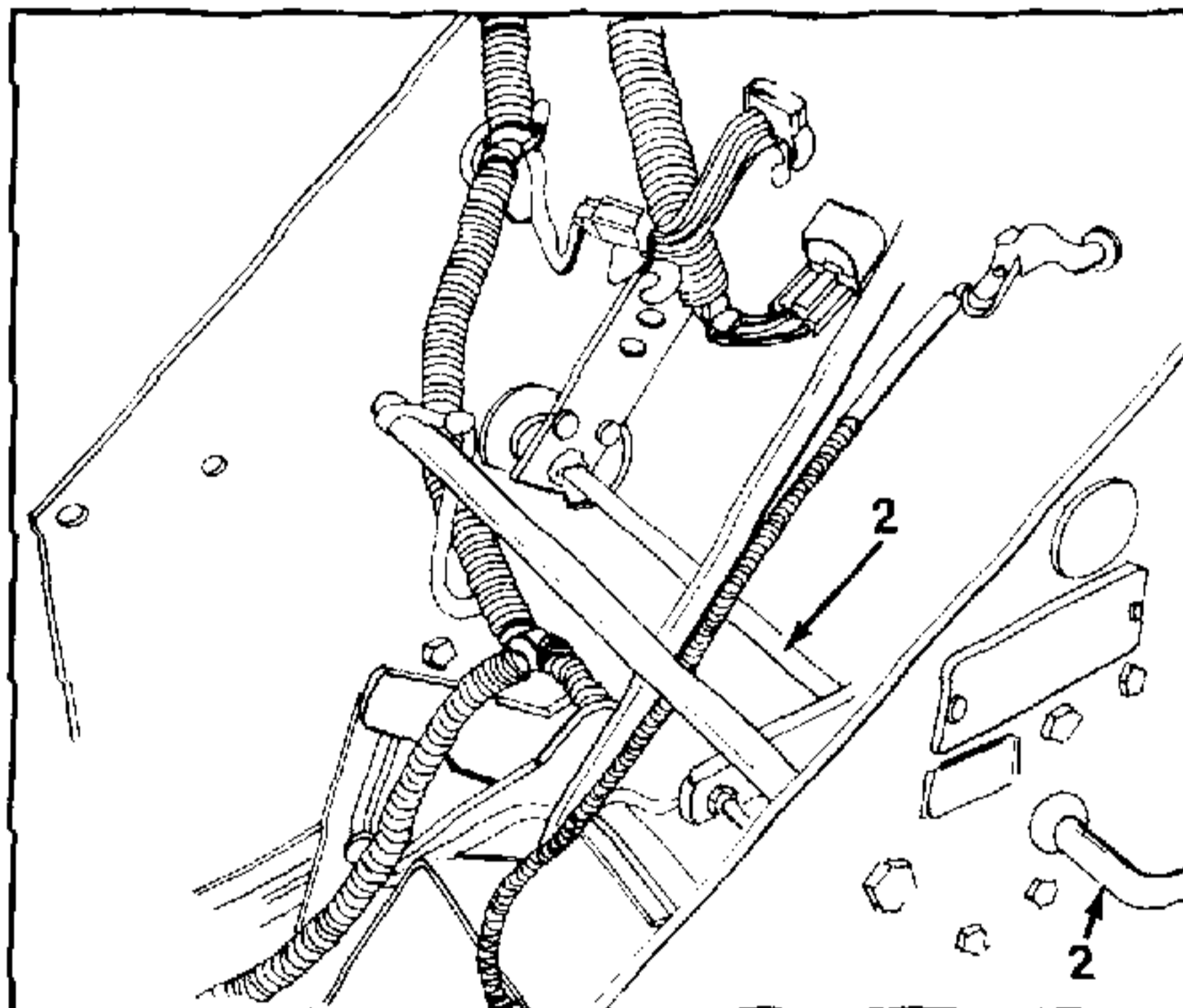

FIGURE 7.

REPLACEMENT OF FRICTION WASHER ON GEAR AND HYDROSTATIC UNITS

- A. On 1315 (or 1989 units remove the gas tank and then proceed.

- B. On 1420 unit, remove the battery and then proceed. Refer to figures 7 and 8.

1. Remove the hex jam nut (Ref. 7), from the shifter assembly (Ref. 2).
2. Remove shoulder spacer (Ref. 6).
3. Remove the hex lock nut (Ref. 11) and lock washer (Ref. 12) from the ball joint (Ref. 10), attached to shift control rod (Ref. 9).
4. Slide the shifter assembly to the right and remove and replace the **friction washer** (Ref. 5).

- | |
|---|
| 1. Shift Knob
2. Shifter Assembly
3. Hex Jam Nut
4. Belleville Washers (2)
5. Friction Washer
6. Shoulder Spacer
7. Hex Jam Nut
8. Friction Bracket
9. Shift Control Rod
10. Ball Joint
11. Hex Lock Nut
12. Lock Washer |
|---|

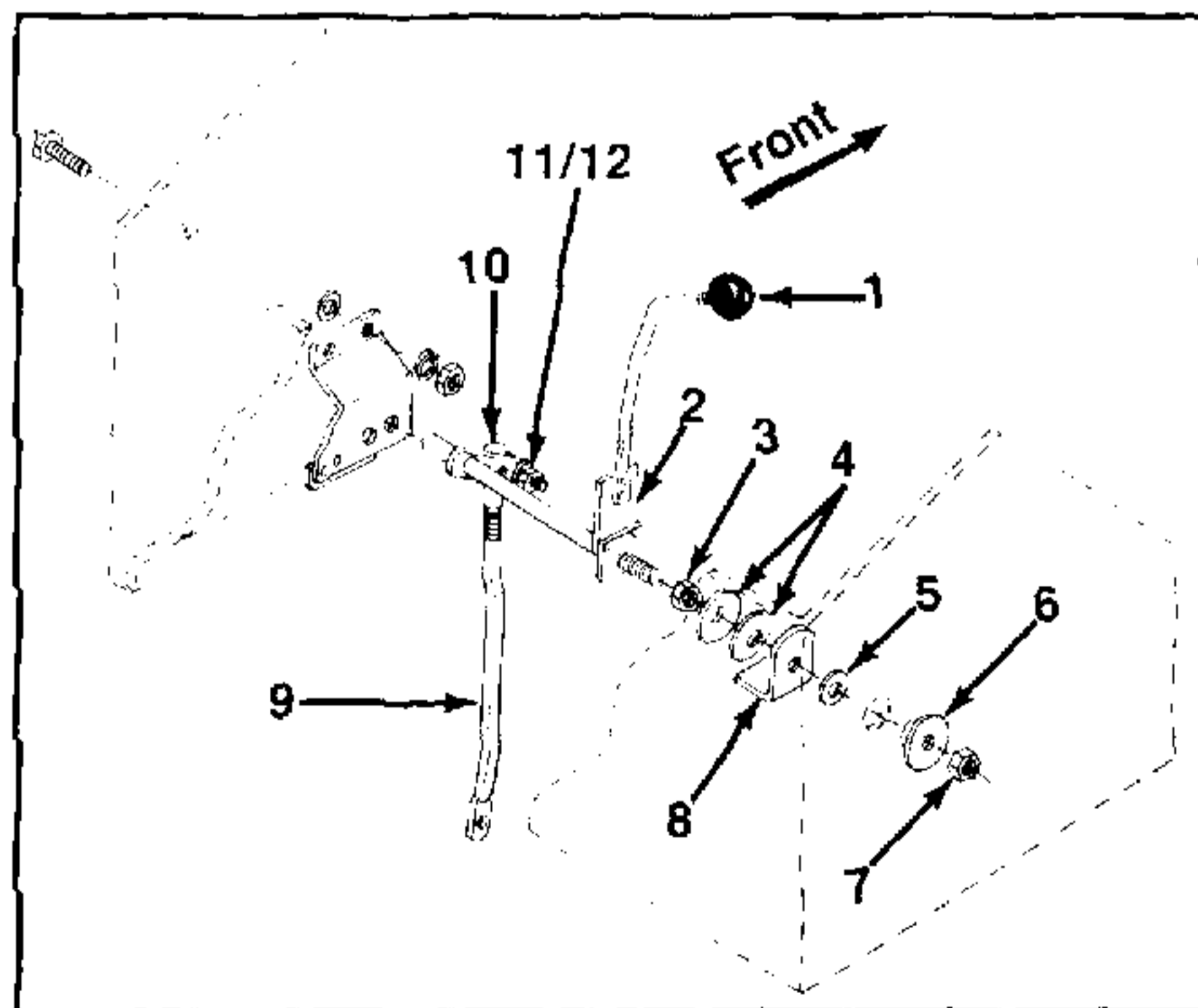

FIGURE 8.

Section 3

MOWER AND SNOW THROWER

Contents

Mowing Deck Adjustments and Belt Replacement—Models 363 and 392	3-2 thru 3-7
Mowing Deck Adjustments and Belt Replacement—Model 441	3-8 thru 3-17
Mowing Deck Adjustments and Belt Replacement—Model 331	3-18 thru 3-29
Mowing Deck Adjustments and Belt Replacement—Model 446	3-30 thru 3-41
40" Snow Thrower	3-42 thru 3-44
Adjustments, Lubrication and Maintenance	3-45 thru 3-46
Exploded Views	3-47 thru 3-50

OPTIONAL EQUIPMENT AND ACCESSORIES

MOWING DECK—ADJUSTMENTS AND OPERATION MODELS 363 AND 392

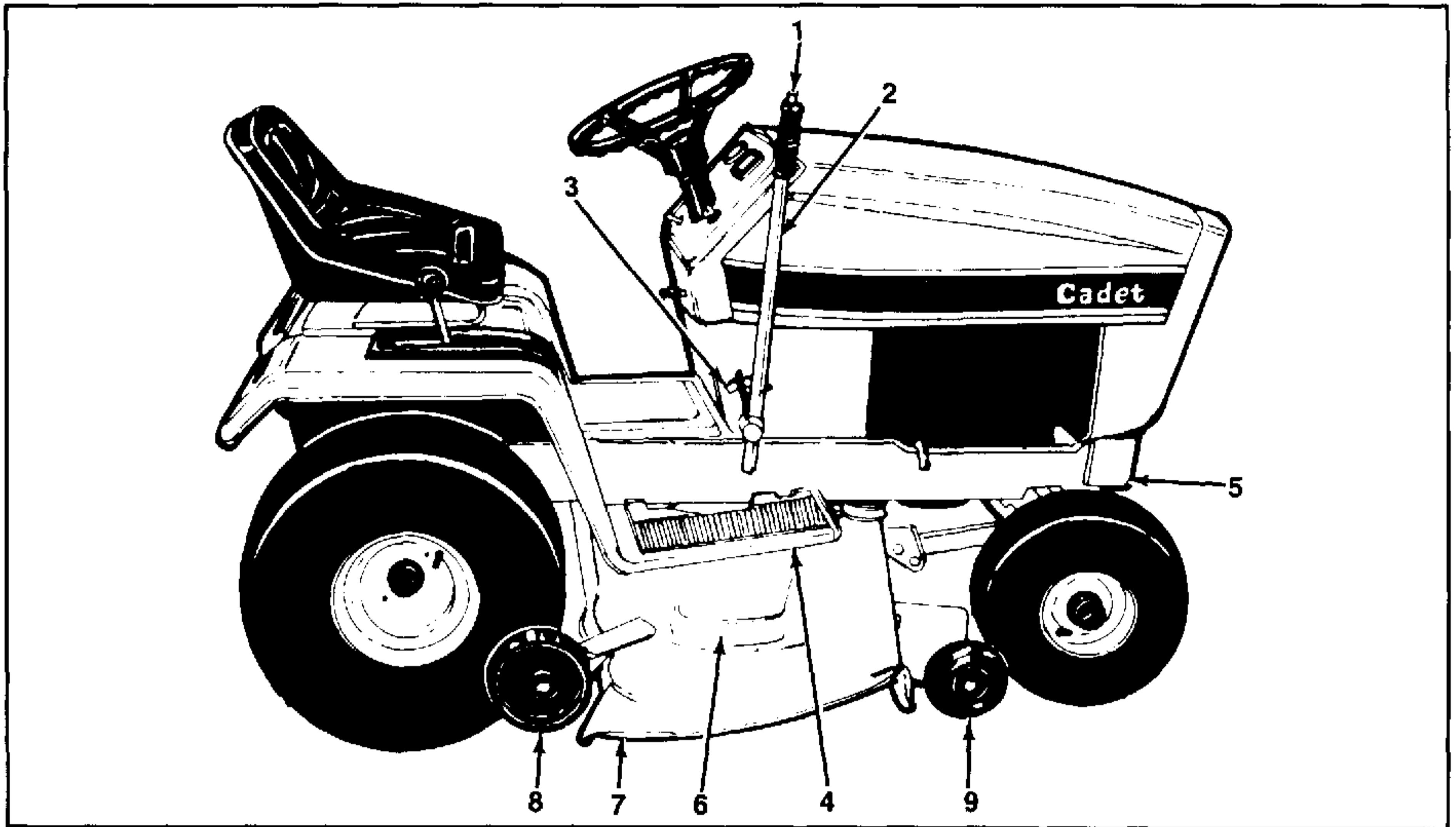

FIGURE 1. MOWER DECK PARTS AND ATTACHMENTS (44 Inch Deck Shown)

1. Lift Lever Release Button
2. Lift Lever
3. Lift Lever Position Decal
4. Mower Support Hangers
5. Quick Hitch Rod

6. Belt Cover
7. Deflector Shield
8. Gauge Wheels
9. Roller

SIDE TO SIDE LEVELING ADJUSTMENT



WARNING

Before making any adjustments, turn off the machine, remove the key and lock the parking brake to avoid accidental starting and injury.



CAUTION

If the mower deck is not level, the mower will not cut your lawn evenly.



NOTE

Check the tires for proper inflation before making a level and height adjustment. To level the mower, place the tractor on a level and hard surface such as a garage floor or sidewalk.

The 38 and 44 inch mowers are equipped with two adjustable lift links. This feature allows the mower to be leveled. (See figure 2.)

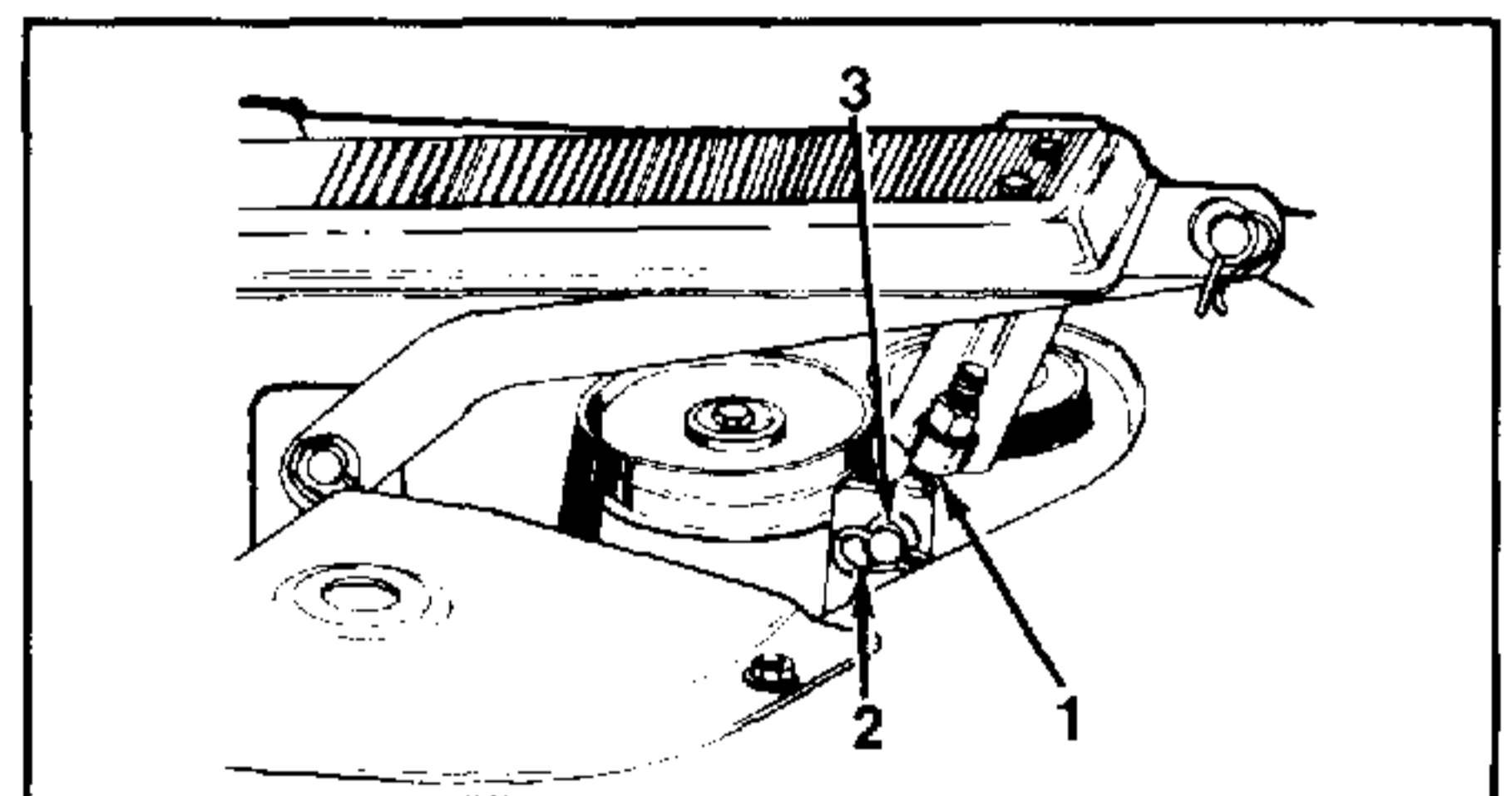

FIGURE 2. (Right Hand Side Shown) (44 Inch Deck)

1. Adjustable Lift Link
2. Hairpin Cotter
3. Flat Washer

To check the side to side leveling of the mower deck, place the unit on a hard level surface. Disconnect the spark plug wires. Place the two outer blades parallel to the unit. Measure the distance from the tip of the blades to the surface on each side. (See figure 3.)

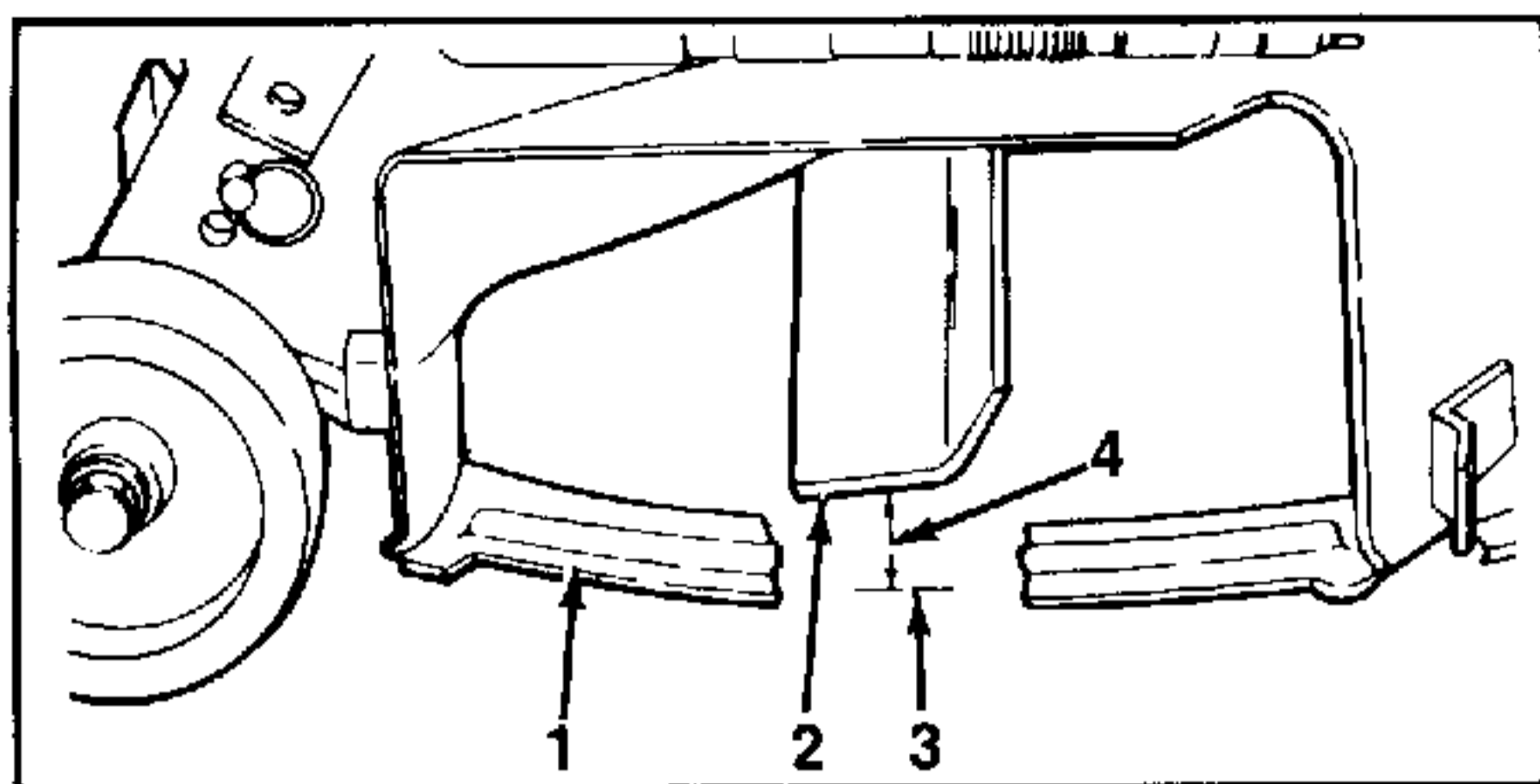

FIGURE 3.

1. Deflector Shield
2. Blade
3. Hard Surface
4. Measure This Distance

If the measurements are not equal, lower the mower deck to the ground. Disconnect one of the adjustable links by removing the hairpin cotter and flat washer which secure it to the deck. Turn the end of the link to the right or left as needed. Reconnect the adjustable link and raise the deck. Recheck the measurement on each, and repeat adjustment until distances are equal.

CUTTING HEIGHT

The mower can be set in multiple positions. Pull the lift handle back slightly and depress button on the top of lift handle. Release the button when the desired mower position is obtained. To return the mower to a specific position, note the position of the lift lever pointer in relation to the lever position decal before raising or lowering the mower.

GAUGE WHEELS AND CASTERS (44 Inch Decks)

Set the gauge wheels and casters just off the hard surface by locating in the proper holes. The gauge wheels and casters prevent scalping and are not meant to set the cutting height. Gauge wheels and casters must be set in the same relative hole locations. (See figure 4.)

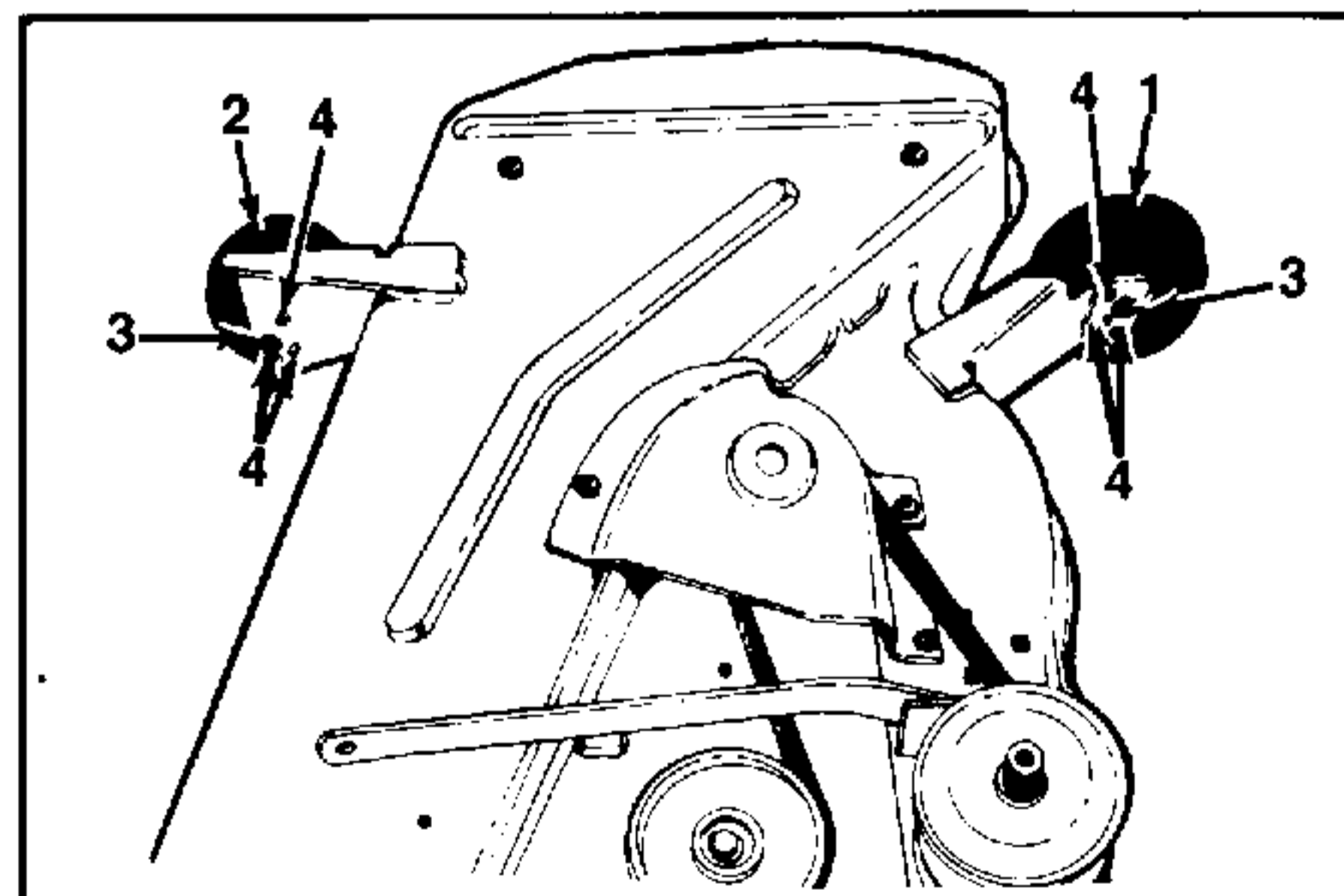

FIGURE 4. (44 Inch Deck)

1. Gauge Wheel
2. Caster
3. 3/8 Inch Nut and Lock Washer
4. Adjustment Holes

GAUGE WHEELS (38 Inch Deck)

Adjust the height of the gauge wheels by pulling out the quick release pin and slide the gauge wheel bracket up or down until desired height is reached. Reinstall the quick release pin. Note that there are half height adjustment holes along with the adjustment holes in the gauge wheel bracket. Both gauge wheels must be set in the same relative hole locations. (See figure 5.)

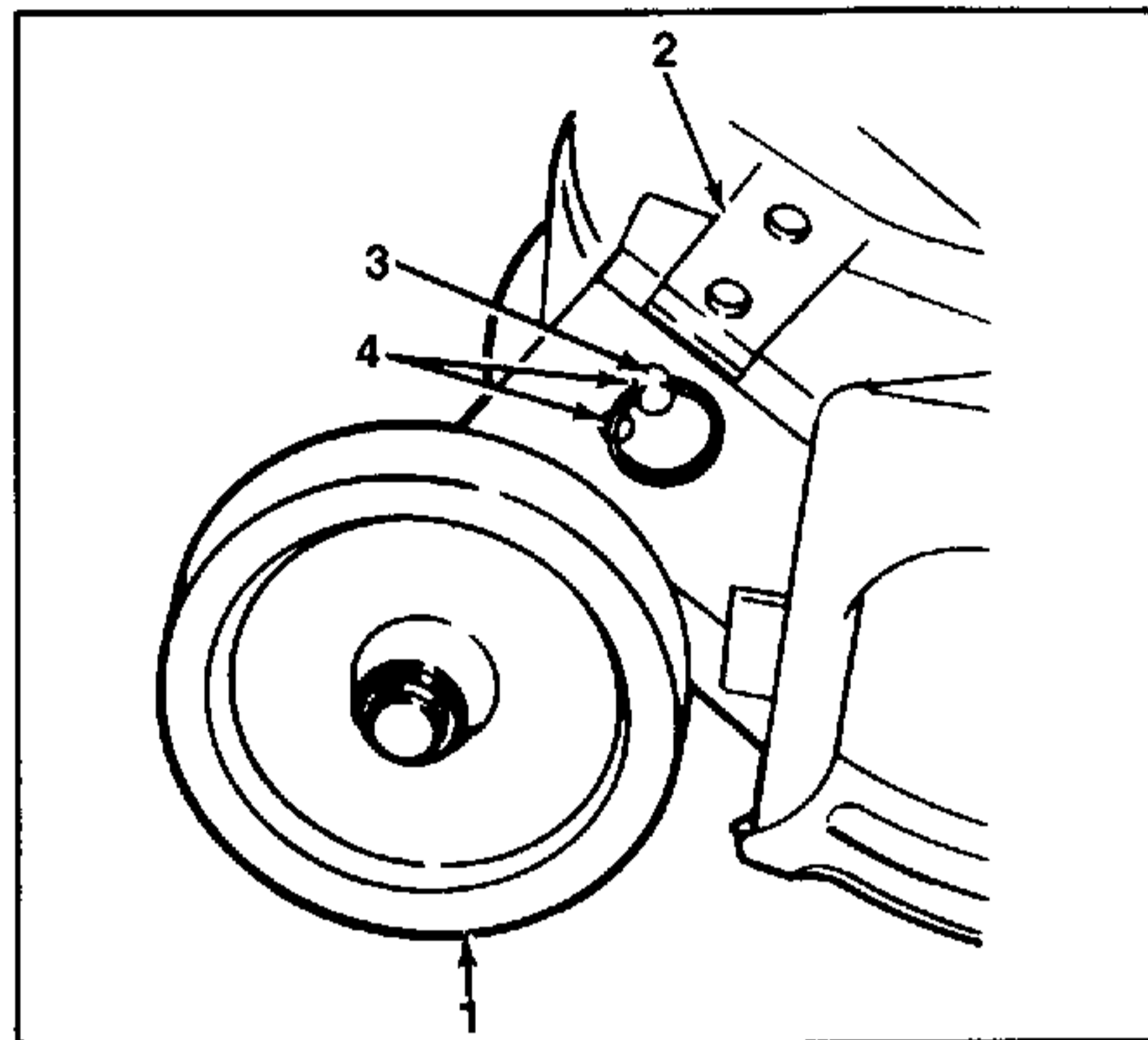

FIGURE 5. (38 Inch Deck)

1. Gauge Wheel
2. Gauge Wheel Bracket
3. Quick Release Pin
4. Half Height Adjustment Holes

STARTING THE MOWER



In heavy grass, full throttle may be needed when starting the mowing deck.

With the engine running at idle speed, start the power take-off clutch. Starting the mower with the engine in idle will reduce wear on the drive belt. Increase engine speed to full throttle.

STOPPING THE MOWER

Move the power take-off (PTO) switch to "OFF" and reduce engine speed.

CLEANING AND BLADE CARE



Stop the tractor, disengage the PTO, place all controls in neutral, engage the parking brake lock and stop the engine before performing any maintenance.



WARNING

Be careful not to cut yourself when sharpening the blades or cleaning the underside of the mower.

Clean the underside of the mower at the end of the mowing season and when the build-up of cut material on the underside is noticed. Also remove the belt cover and remove any accumulation.

The cutting blades must be kept sharp at all times.

NOTE

Sharpen ends evenly so that the blades remain balanced and the same angle of sharpness is maintained. However, if the cutting edge of a blade has been sharpened to within 3/8 inch of the wind wing, it is recommended that new blades be installed. New blades are available at your authorized dealer.

When removing the blades, hold the hex shaped pulley hub with a 1-1/4 inch socket wrench to remove the hex nut holding the blade. A block of wood may be placed between housing and cutting edge of blade to assist in removal of hex nut securing blade. (See figure 6.)

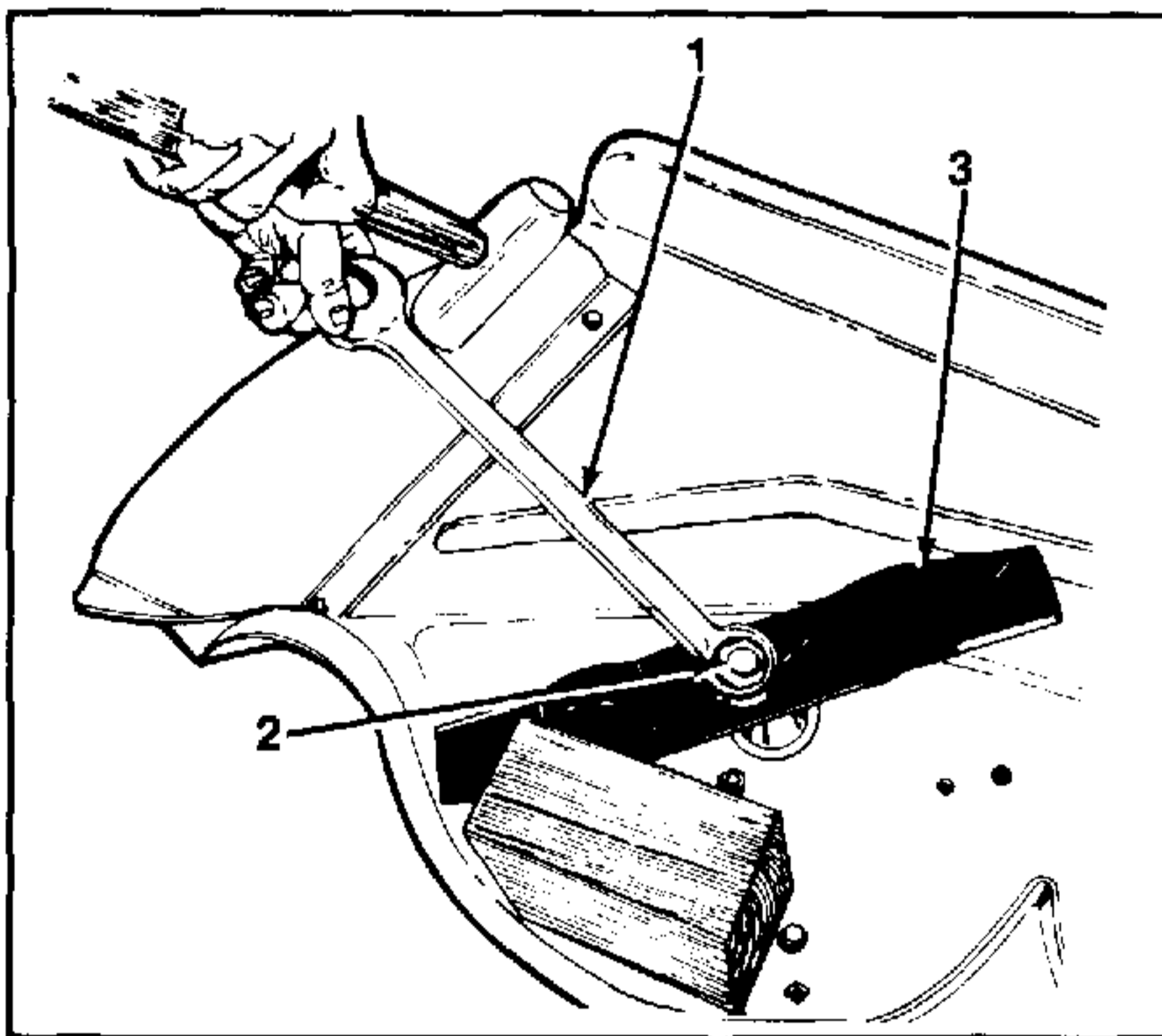

FIGURE 6.

- 1. 1-1/8 Inch Wrench
- 2. Hex Nut
- 3. Blade

After replacing blades, grease the threaded end of the shaft to prevent rust build-up.

When replacing the blades, be sure they are assembled so the cutting edges are in the direction of rotation with the wind wings pointed upward. Tighten the nuts 50 to 60 ft-lbs. (68 to 81 N-m).

NOTE

If the spindle pulley nuts are removed for any reason, they should be retightened to 90 to 110 ft-lbs. torque when replaced.

LUBRICATION

After every 100 hours of operation, and/or before putting into winter storage, lubricate the spindle assemblies using 251H EP grease or equivalent No. 2 multi-purpose lithium grease. The grease will be expelled from the top spindle seal. Since the spindle pulley covers the top spindle seal, the expelled grease cannot be seen. When the spindle is fully greased, the expelled grease will cause the top spindle seal to give off a muffled crackling noise. (See figure 7 for the 38 inch deck or Figure 8 for the 44 inch deck.)

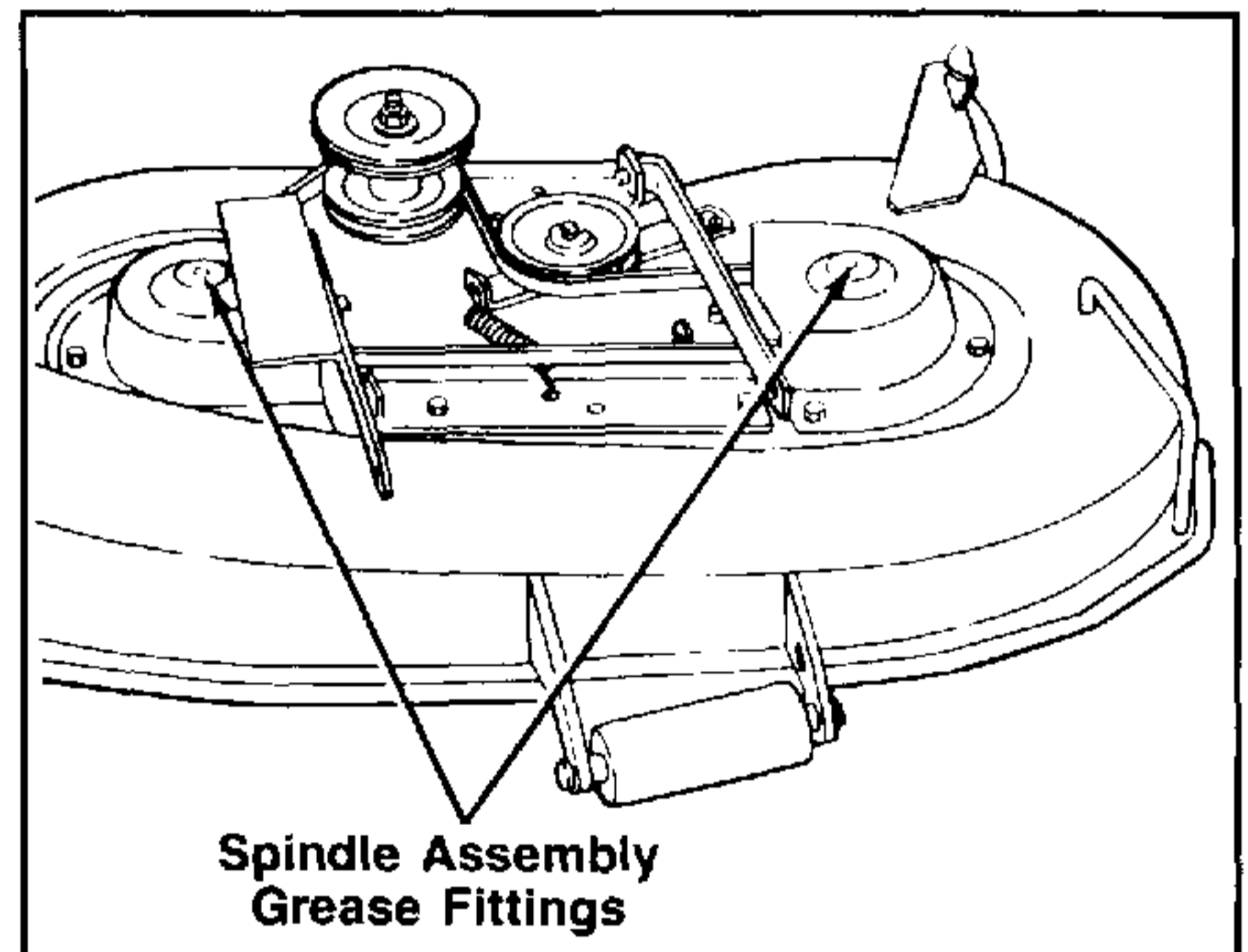

FIGURE 7. (38 Inch Deck)

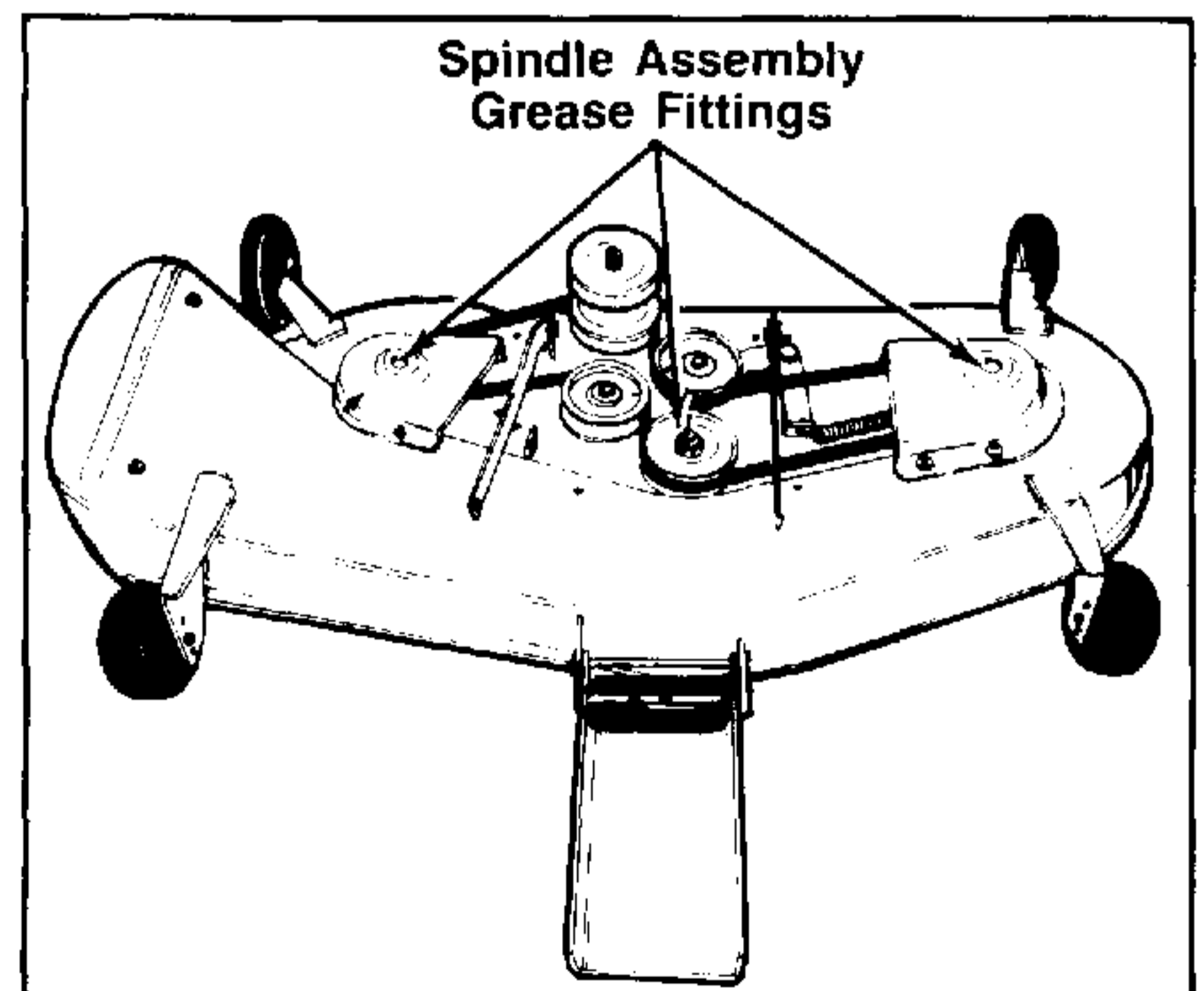

FIGURE 8. (44 Inch Deck)

**SPINDLE DRIVE BELT REPLACEMENT
(38 Inch Deck)**

Replace spindle drive belt as follows: (See figures 9, 10 and 11.)

1. Remove the nuts and washers that secure both spindle belt covers to the deck.
2. Remove the spindle belt covers to expose the belt.
3. Push against the idler pulley to release tension on drive belt.
4. Remove old drive belt.
5. Install a new belt. Refer to figures 9, 10 and 11 for proper placement of belt. Push against idler pulley to aid the installation.
6. Reinstall spindle belt covers and hardware.

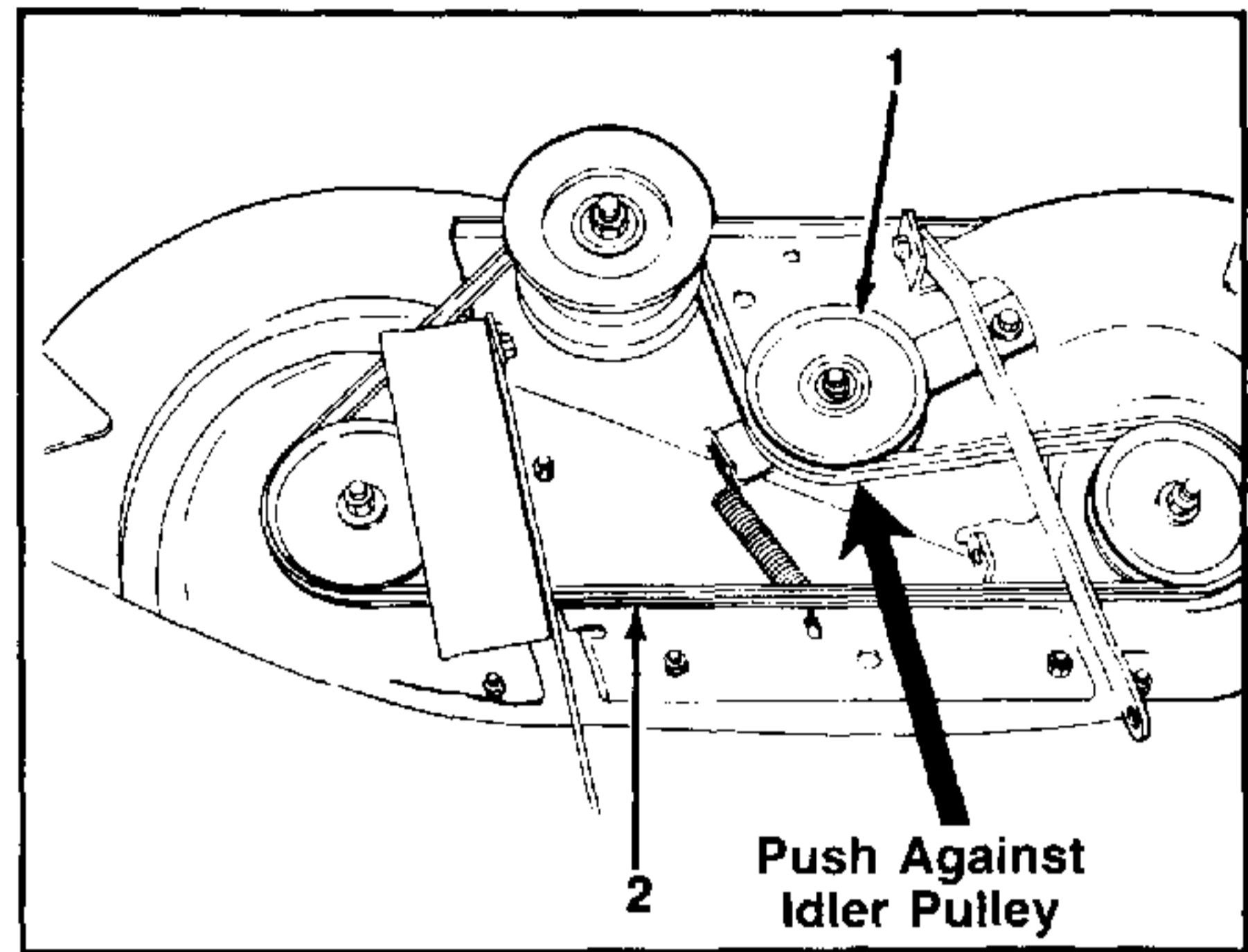

FIGURE 11.

1. Idler Pulley
2. Spindle Drive Belt

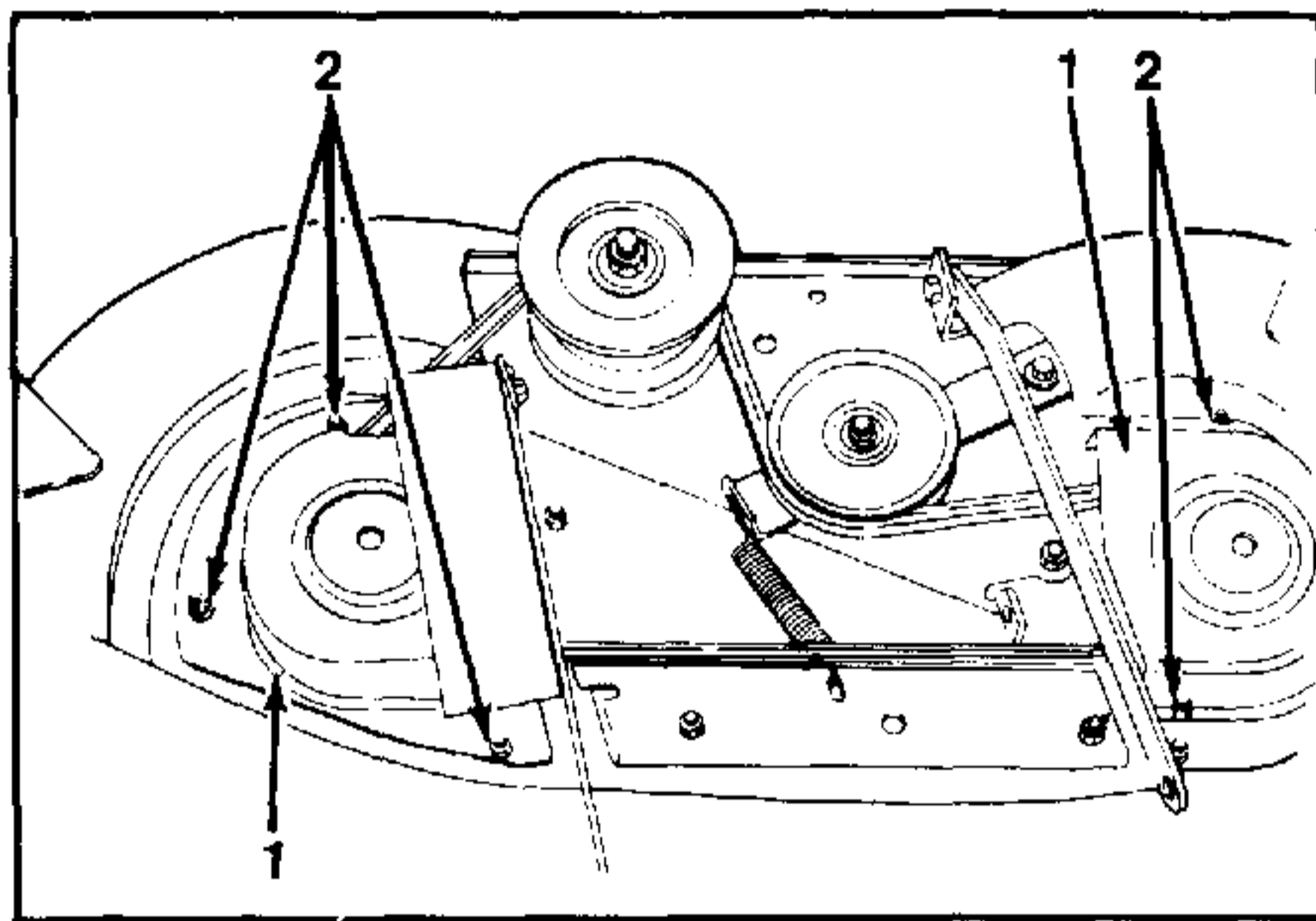

FIGURE 9.

1. Spindle Belt Cover
2. Nuts and Washers

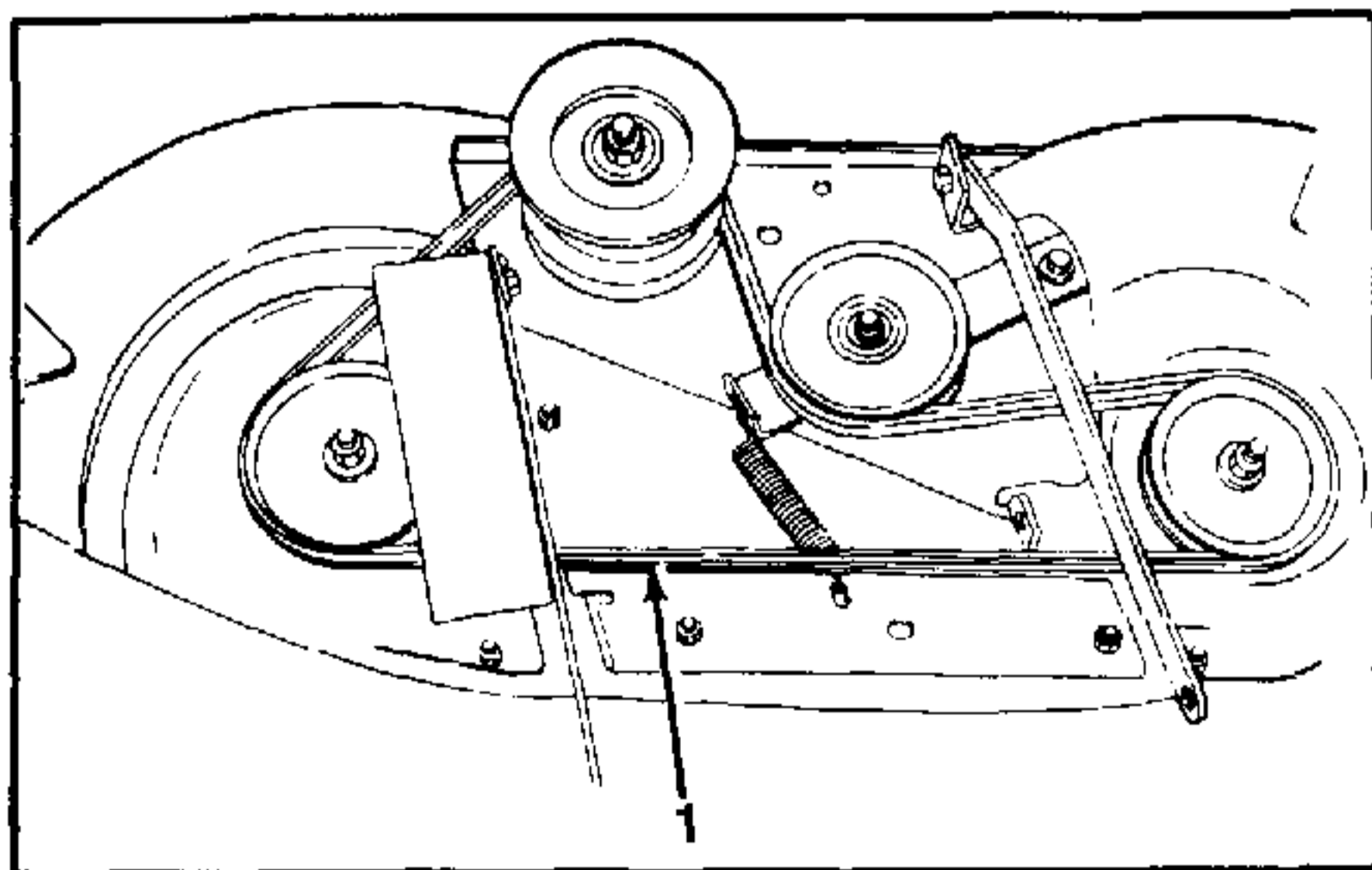

FIGURE 10.

1. Spindle Drive Belt

**SPINDLE DRIVE BELT REPLACEMENT
(44 Inch Deck) (See Figures 12, 13 and 14)**

To replace spindle drive belt, remove belt covers. Release spring tension. Remove the old belt. Install the new belt around pulleys as shown in figures 44, 45 and 46. Be certain belt is in lower groove of the center pulley. Reinstall covers.

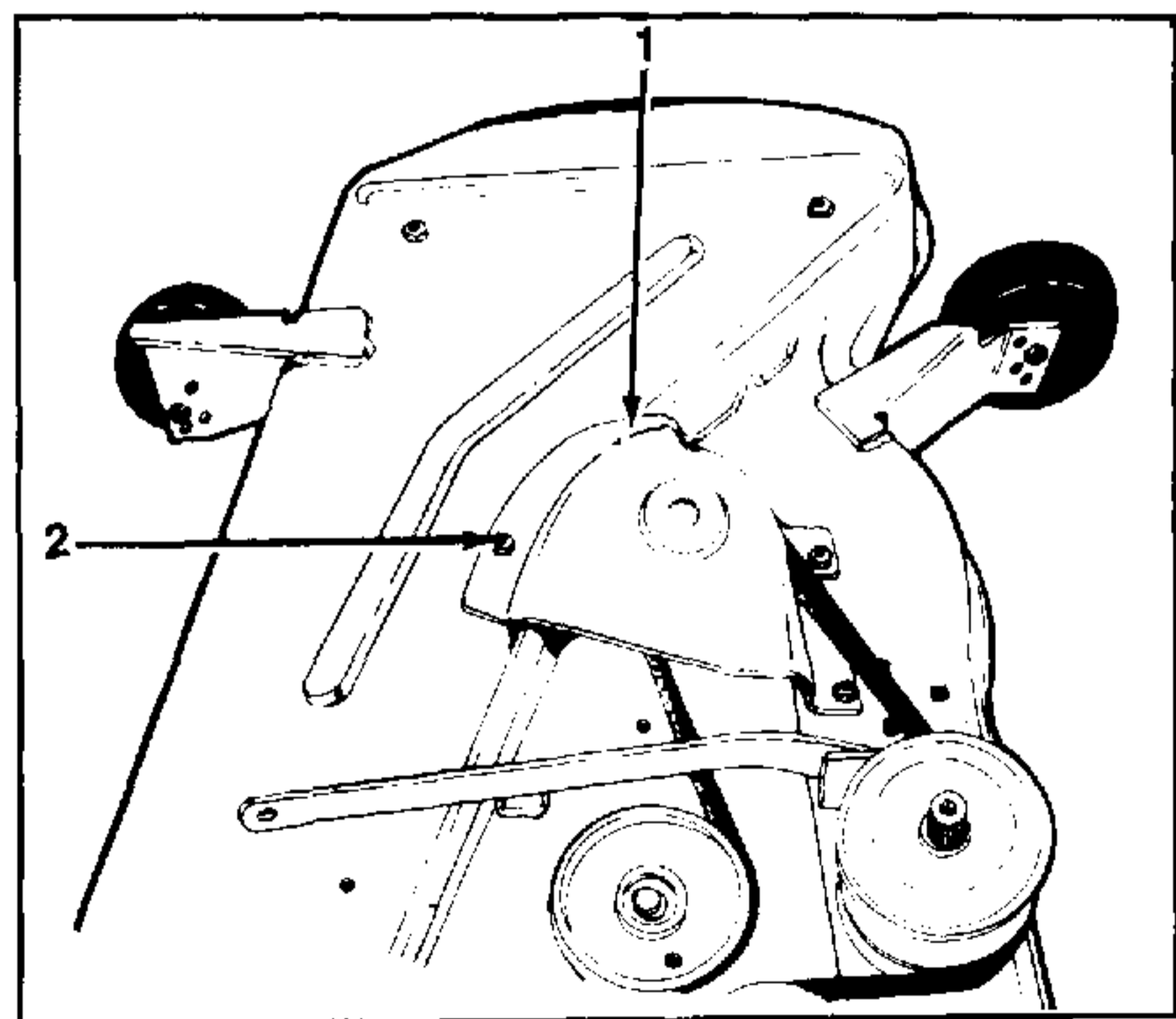

FIGURE 12.

1. Spindle Belt Cover
2. Nuts and Washers

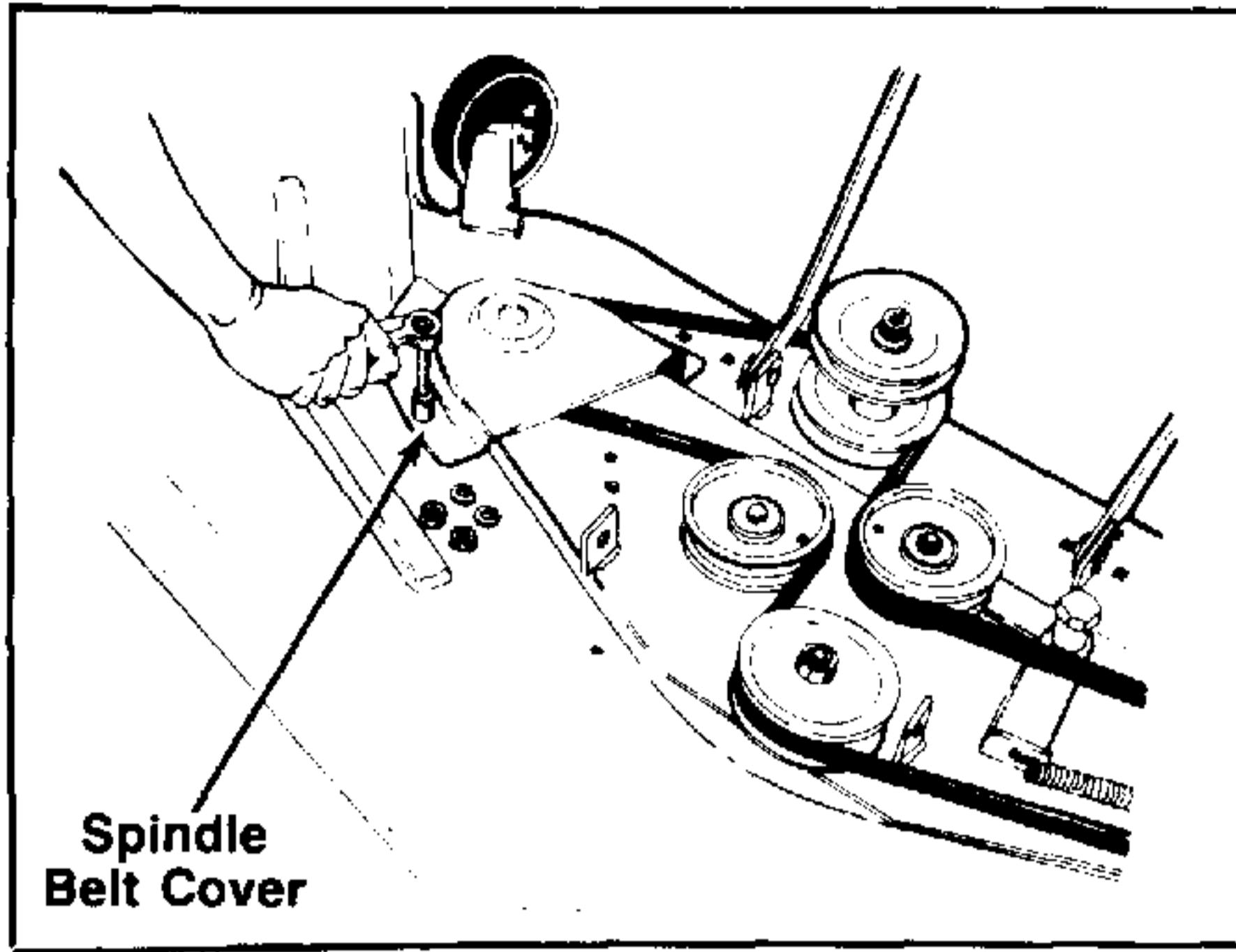

FIGURE 13.

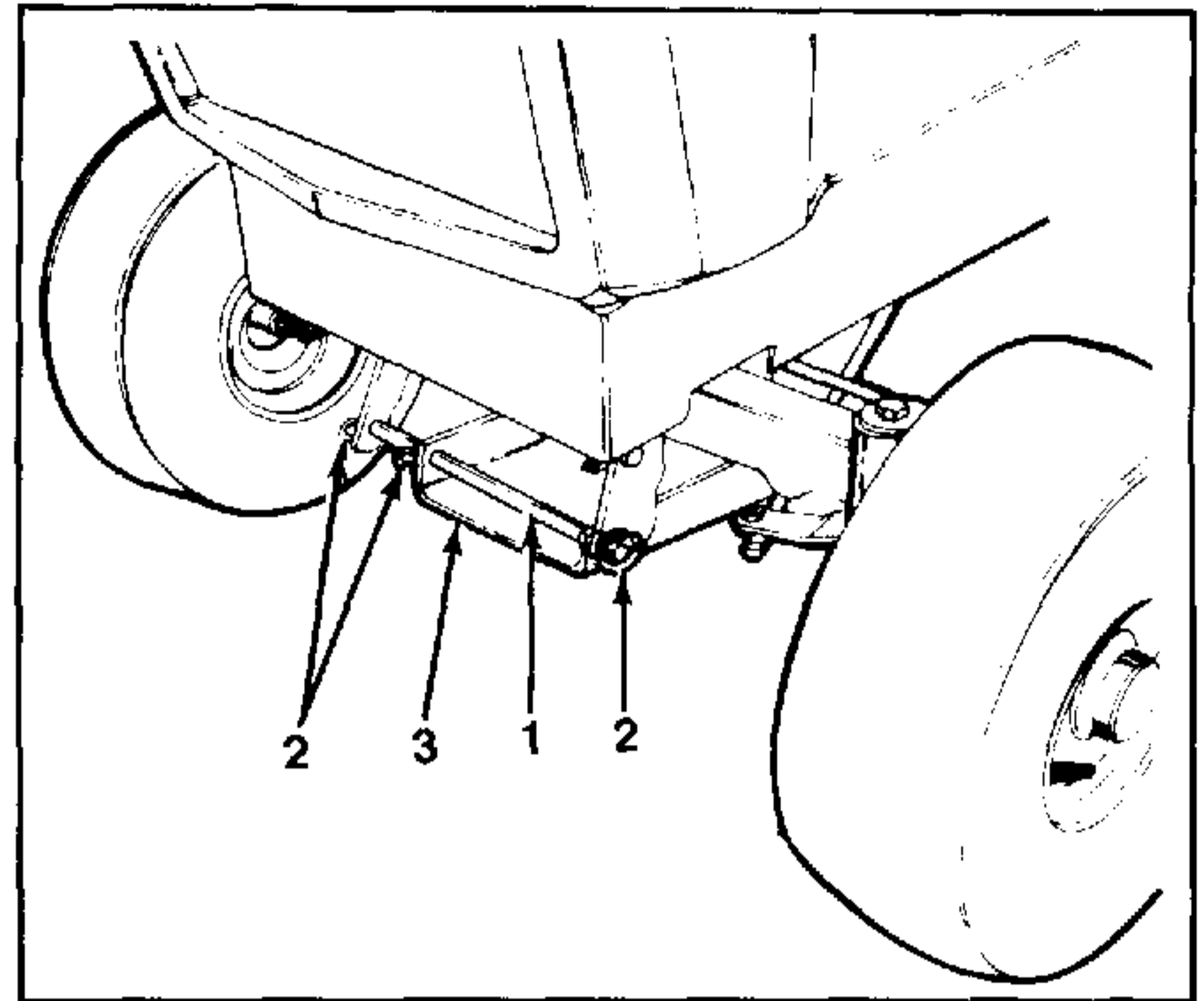

FIGURE 15.

1. Hanger Rod
2. Hairpin Cotters and Flat Washers
3. Front Hanger Assembly

2. Attach deck hangers and adjustable lift links using hairpin cotters and flat washers as shown in figures 16 and 17.

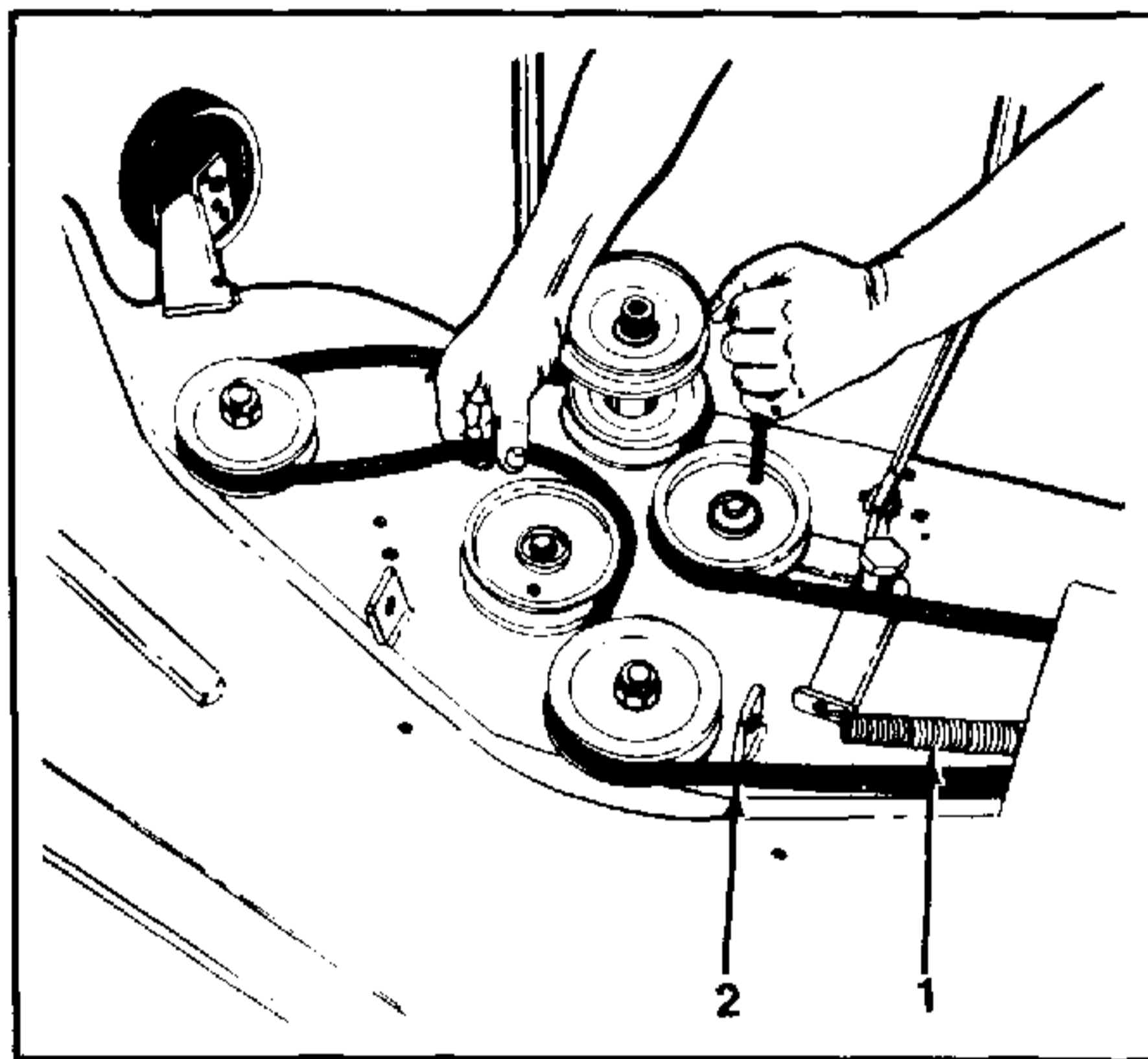

FIGURE 14.

1. Idler Spring
2. Spindle Drive Belt

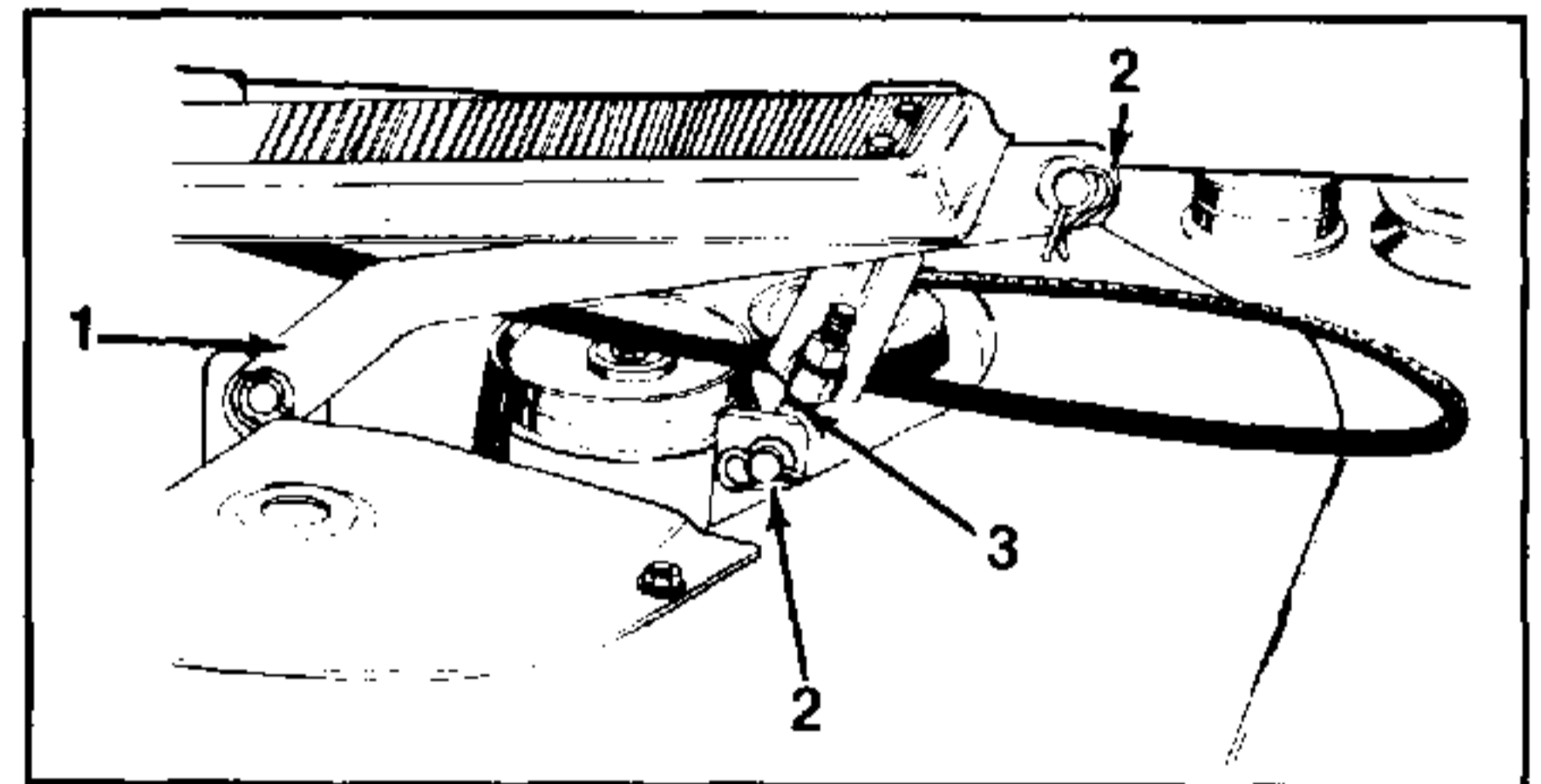

FIGURE 16. Right Side of Deck

1. Deck Hanger
2. Hairpin Cotter and Flat Washer
3. Adjustable Lift Link

ATTACHING MOWER TO TRACTOR

➔ NOTE

Figures 15 through 20 illustrate attaching the mower deck to the tractor. The 38 inch deck is shown, but is typical of both the 44 inch deck and the 38 inch deck.

1. Assemble the front hanger assembly to the tractor as shown in figure 15.

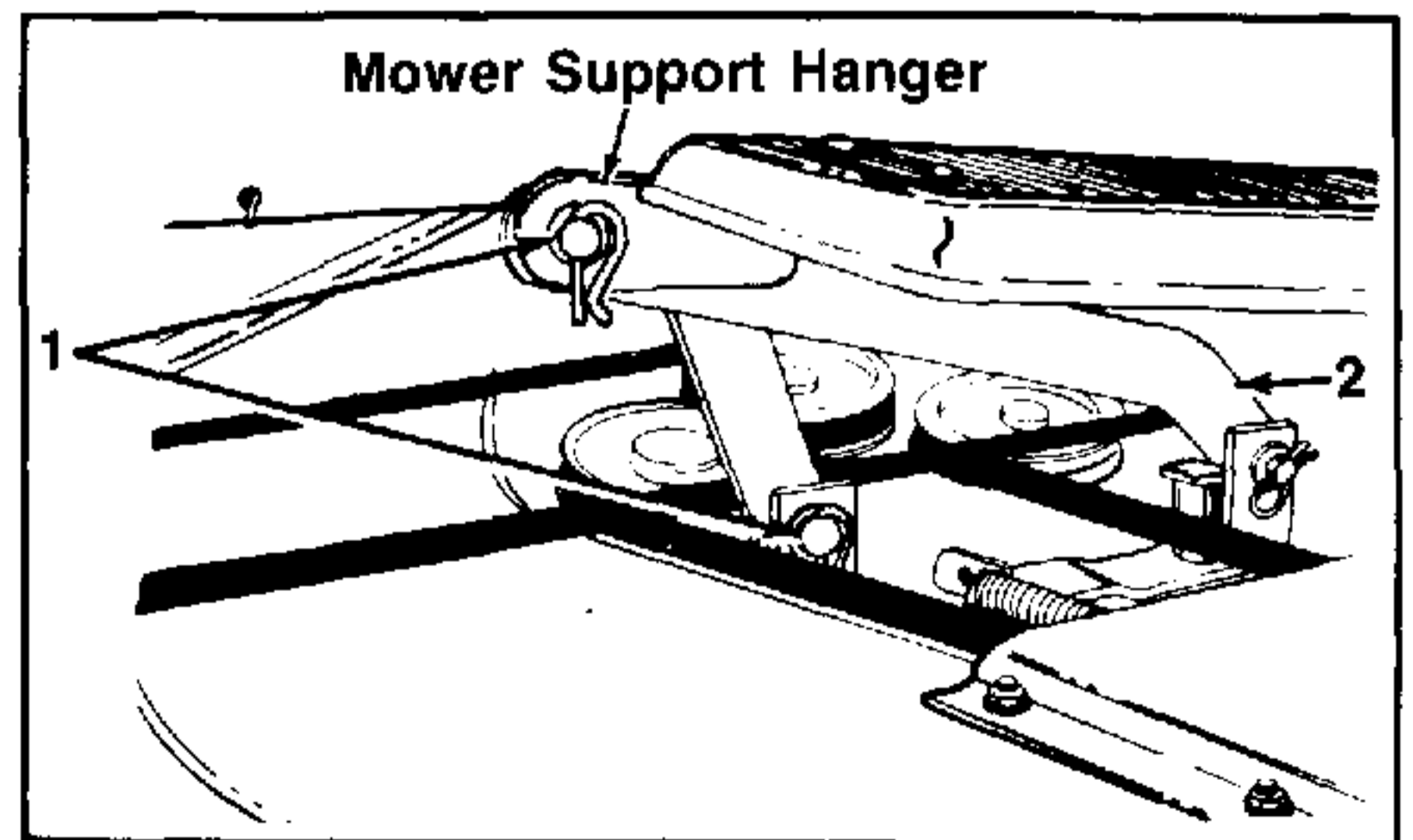

FIGURE 17. Left Side of Deck

1. Hairpin Cotter and Flat Washer
2. Deck Hanger

3. Install spindle belt by slipping belt over electric PTO pulley. (See figure 18.)

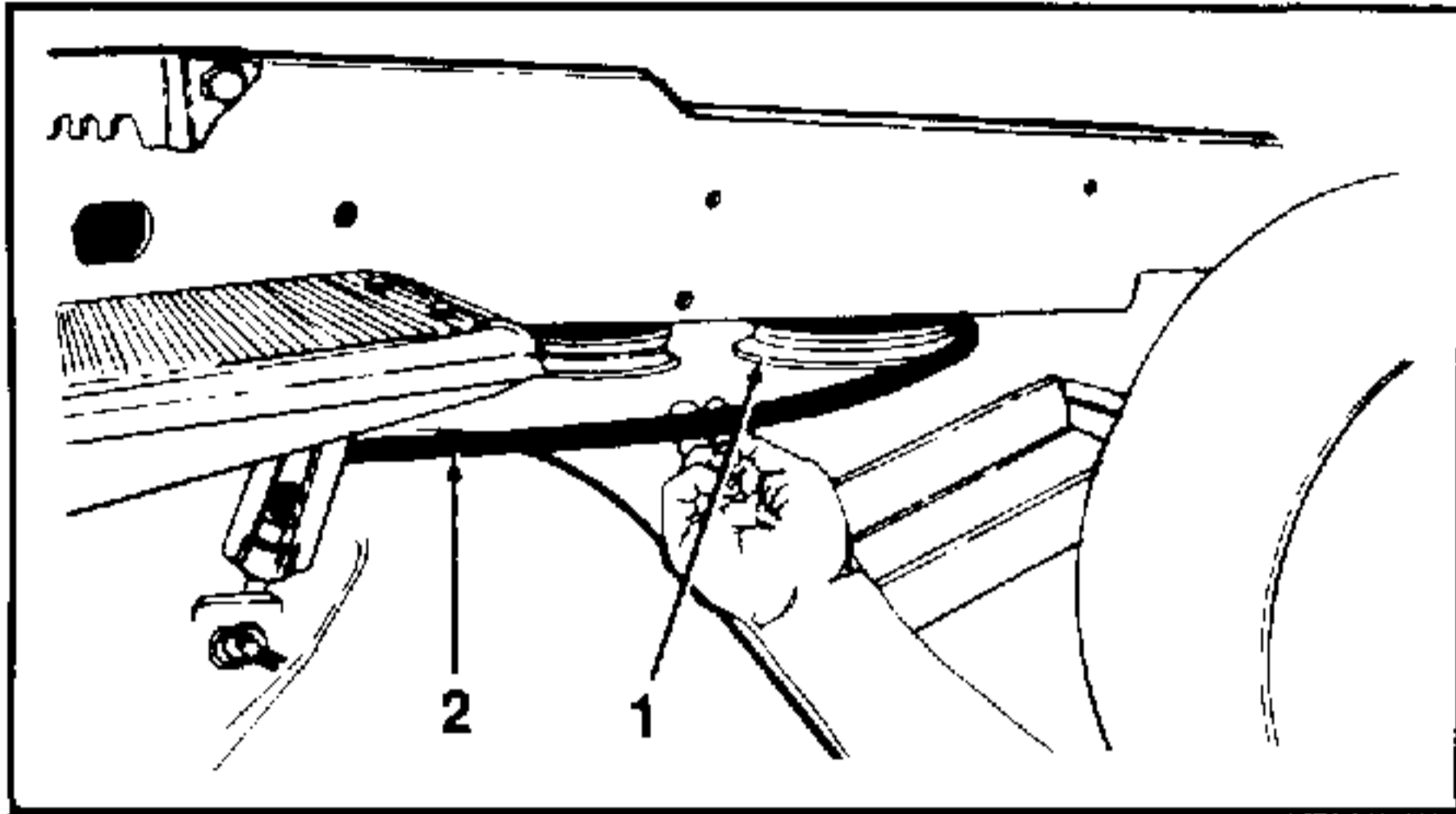

FIGURE 18.

- 1. Electric PTO Pulley
- 2. Drive Belt

4. Pull idler pulley away from the tractor and then place drive belt behind it. Release idler pulley. (See figure 19.)

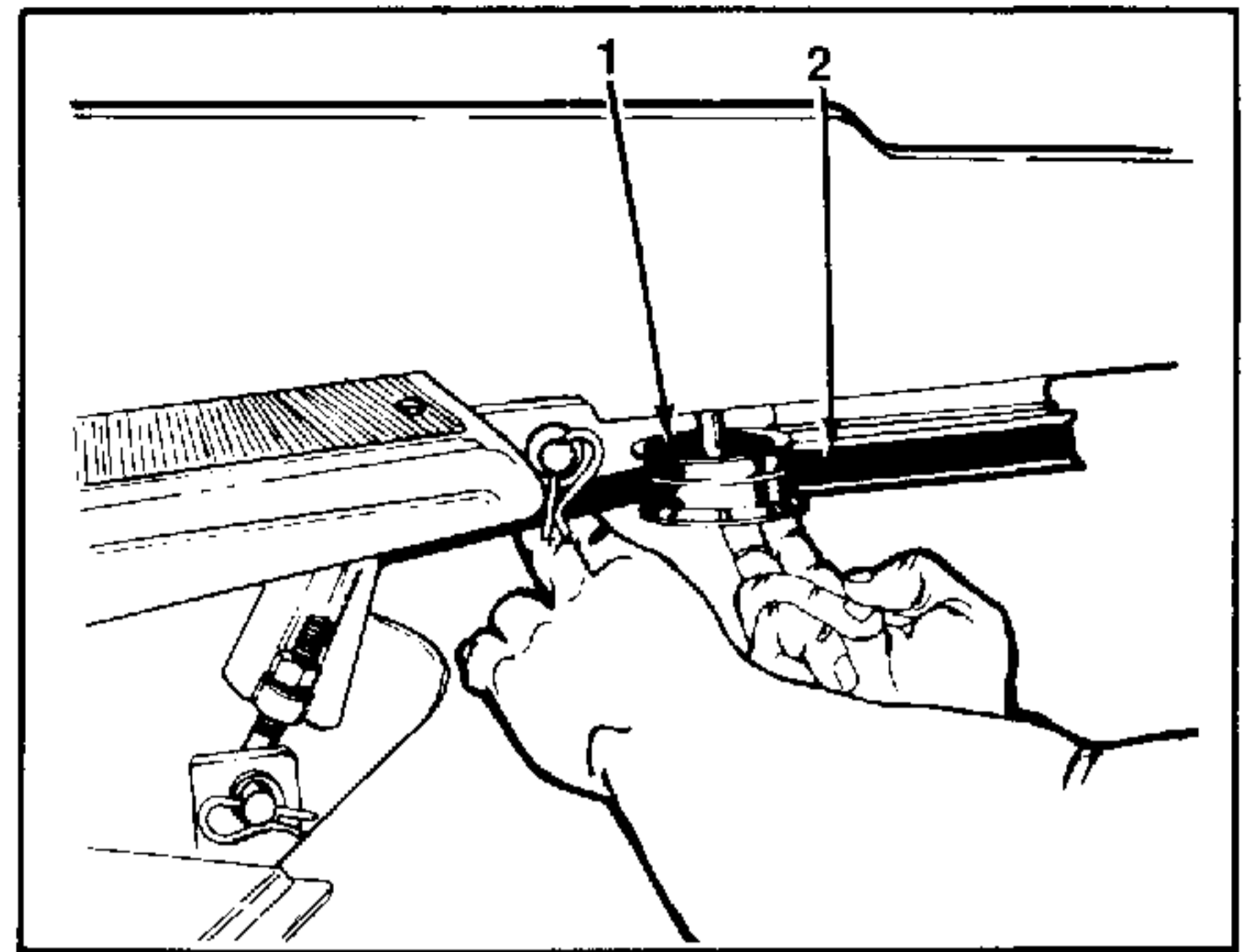

FIGURE 19.

- 1. Idler Pulley
- 2. Drive Belt

➔ NOTE

In all cases the rear deck hangers should be attached to the inside of the mower support hangers on the tractor as shown in figure 17. Figure 20 illustrates the correct deck connections to front and rear deck hangers. Ensure that front and rear deck hangers are installed onto deck as shown in figure 20.

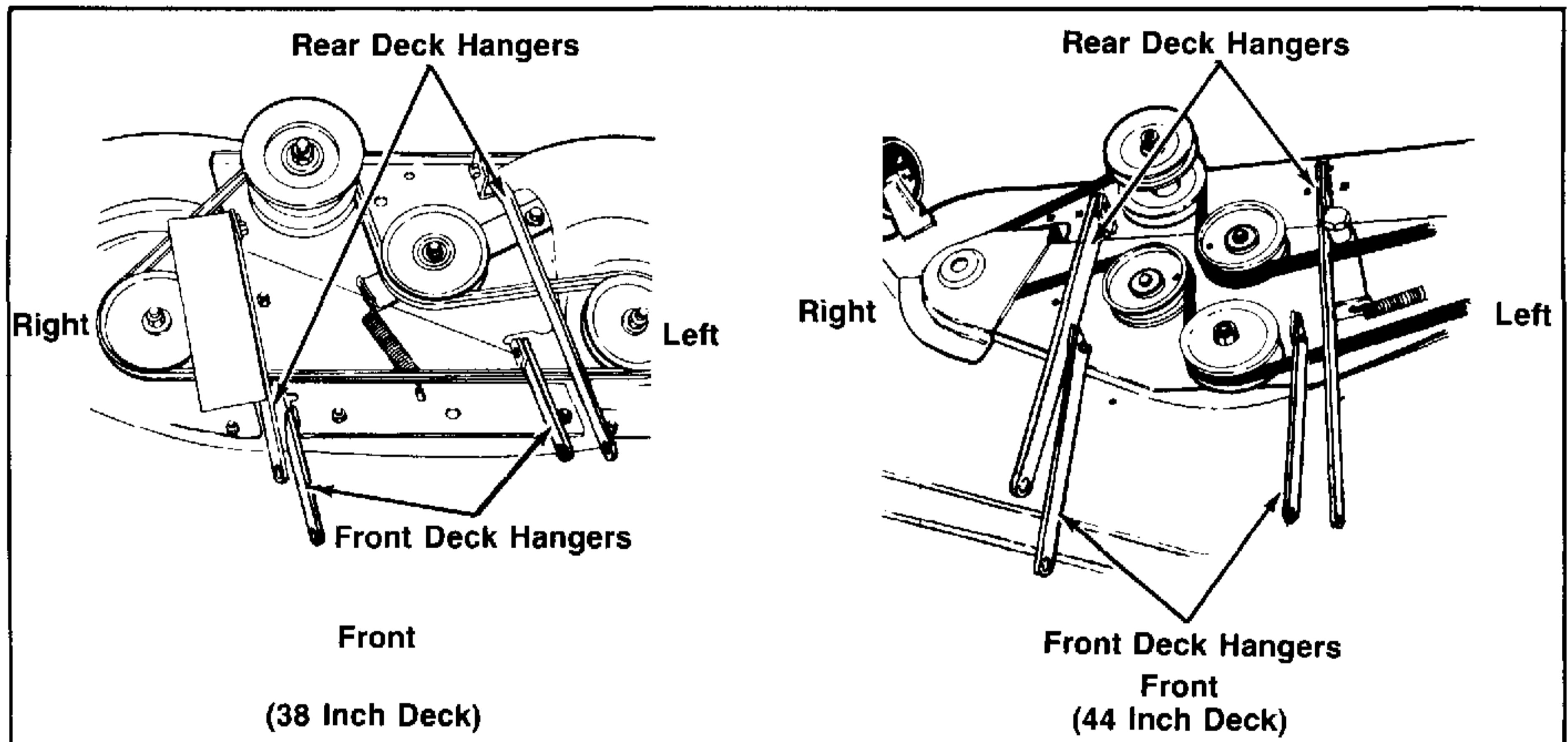

FIGURE 20.

MOWING DECK— ADJUSTMENTS AND OPERATION MODEL 441

SECTION I. DECK ASSEMBLY COMPONENTS



WARNING

When handling the mower deck, be careful not to cut yourself on the sharp blades.

Remove deck components from the container. Refer to figure 1 to ensure that all parts are present and to acquaint yourself with parts' nomenclature.

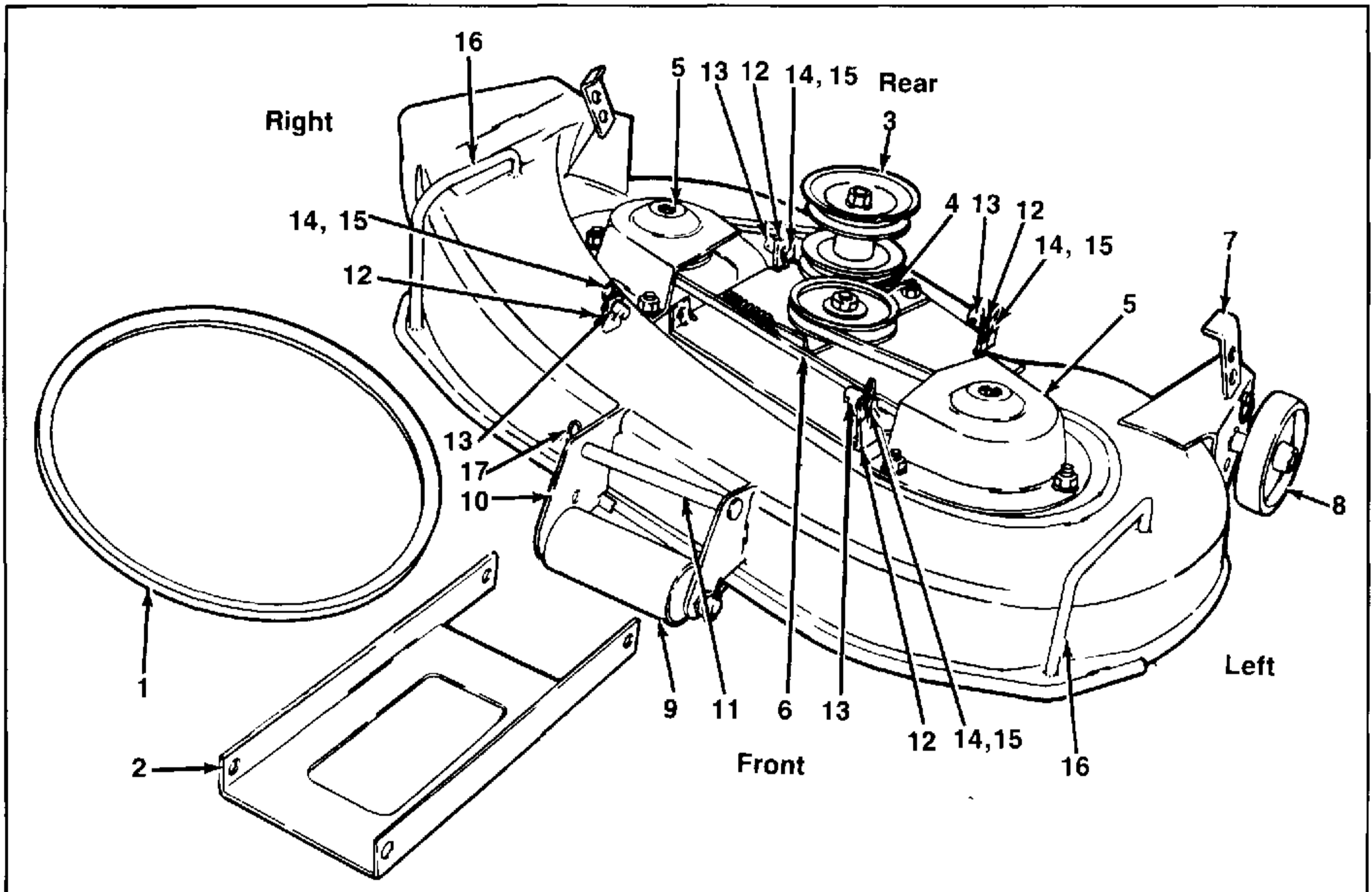

FIGURE 1.

- | | | |
|-----------------------------|-----------------------------|---------------------|
| 1. Front PTO Drive Belt | 6. Spindle Drive Belt | 11. Deck Hanger Rod |
| 2. Front Hanger Assembly | 7. Height Adjusting Bracket | 12. Lift Bracket |
| 3. Double Drive Pulley | 8. Gauge Wheel | 13. Ferrule |
| 4. Flat Idler Pulley | 9. Front Roller | 14. Cotter Pin |
| 5. Blade Spindle Belt Cover | 10. Front Roller Bracket | 15. Flat Washer |
| | | 16. Deck Handle |
| | | 17. Hairpin Cotter |

SECTION II. INSTALLATION OF DECK ASSEMBLY

A. PREPARATION

Prior to beginning installation of the deck, refer to figure 1 and complete the following preparations:

1. Remove the hairpin cotter and the flat washer from the end of the deck hanger rod. Then remove the deck hanger rod.
2. **Note the relative position of the right rear ferrule to the mounting bracket.** Remove the cotter pins and flat washers securing the ferrules. Remove the front and rear ferrules from the deck.
3. Check that the gauge wheels are in the lowest position. Refer to figure 2. If wheel(s) are not in the lowest position, retract the quick release pin and place the wheel in the lowest position.

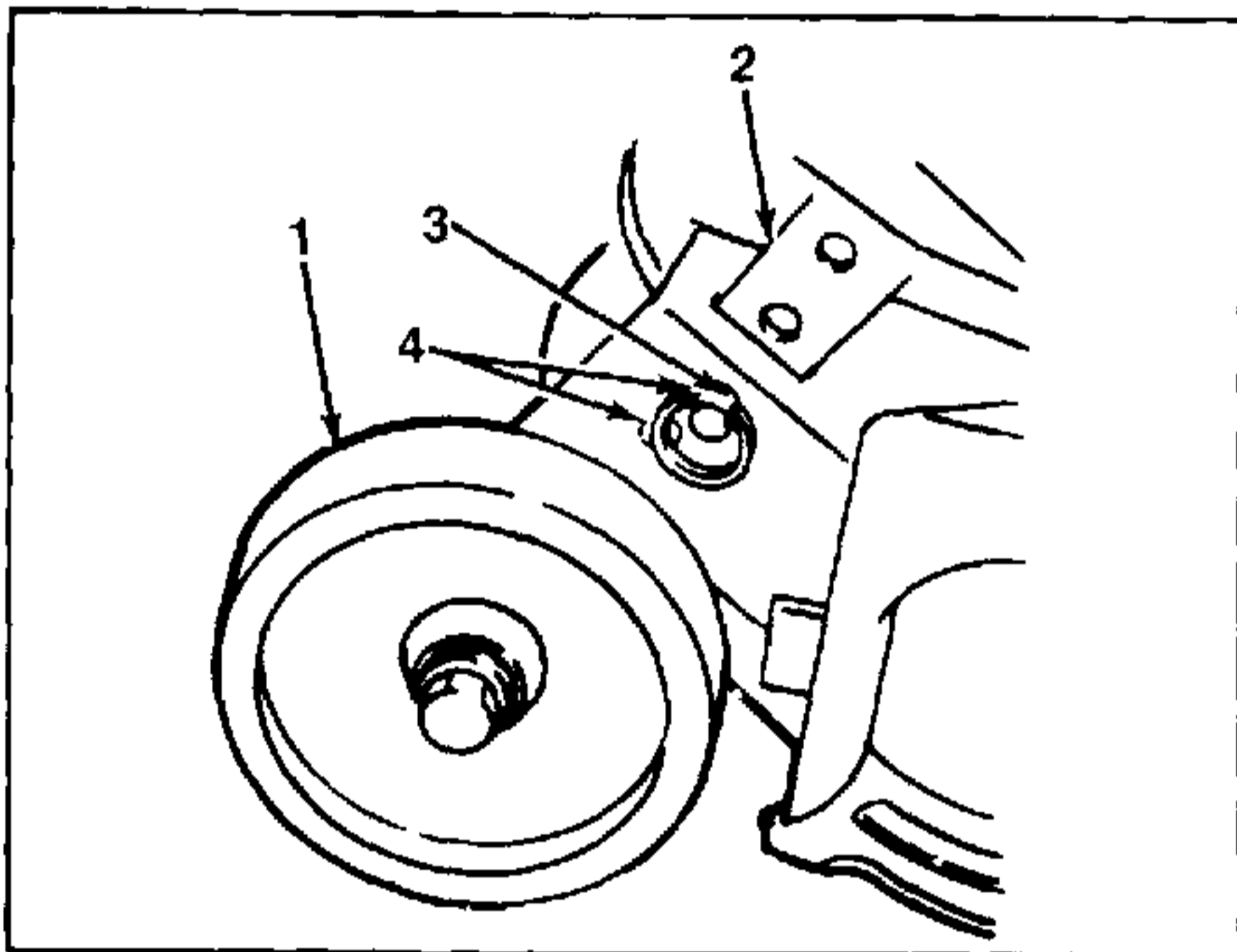

FIGURE 2.

1. Gauge Wheel
2. Gauge Wheel Bracket
3. Quick Release Pin
4. Half Height Adjustment Holes

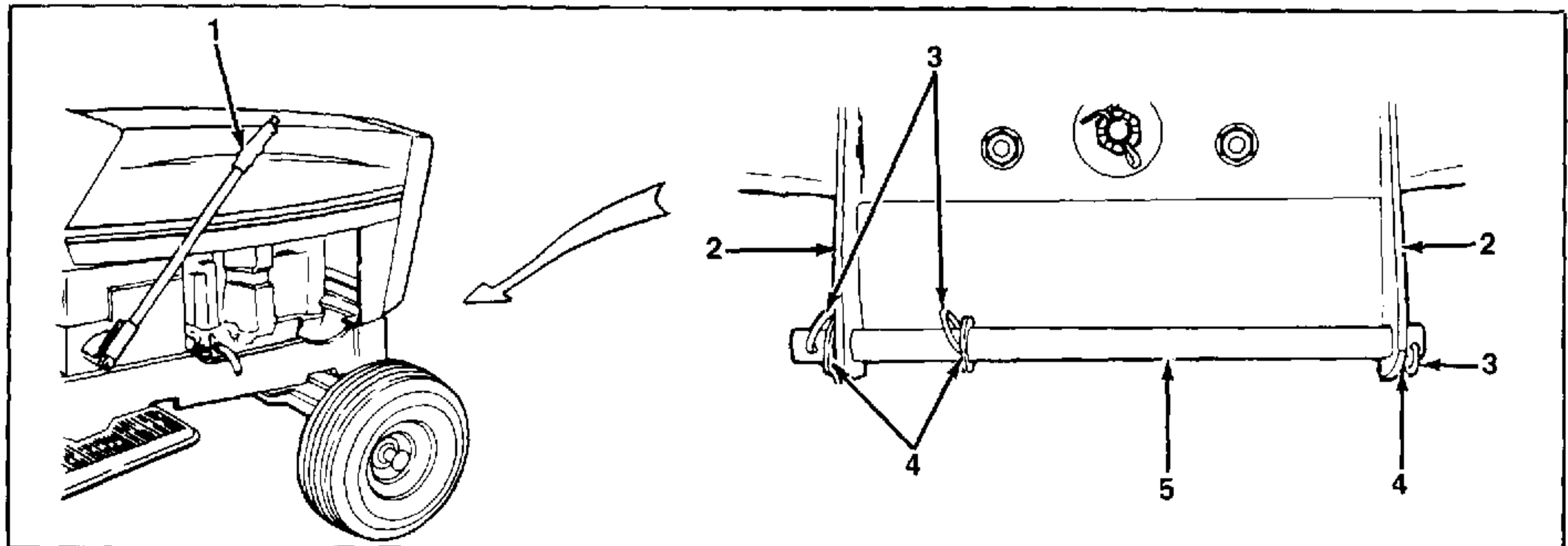

FIGURE 3.

1. Lift Handle
2. Front Hanger Bracket
3. Hairpin Cotter
4. Flat Washer
5. Front Bracket Rod

B. INSTALLATION OF DECK



WARNING

Stop the tractor engine, disengage the PTO, place all controls in neutral and engage the brake pedal lock before performing deck installation.



WARNING

When handling the mower deck, be careful not to cut yourself on the sharp blades.



CAUTION

The mower deck must be placed on a hard level surface during installation.

Proceed with deck installation as follows:

1. Refer to figure 3. Using the steering wheel, turn the left front wheel to the left as far as possible. Remove the hairpin cotters from the right end and from the center of the tractor hanger rod. Withdraw the rod from the front hanger bracket. Collect the washers.
2. Place the lift handle at its lowest setting.
3. Refer to figure 4. Note the relative position of the flat area at the top of the two rear lift links to the welded lift pins on the lift carriage. Remove the hairpin cotters and flat washers which attach the rear lift links to the lift pins. Remove the two rear lift links.

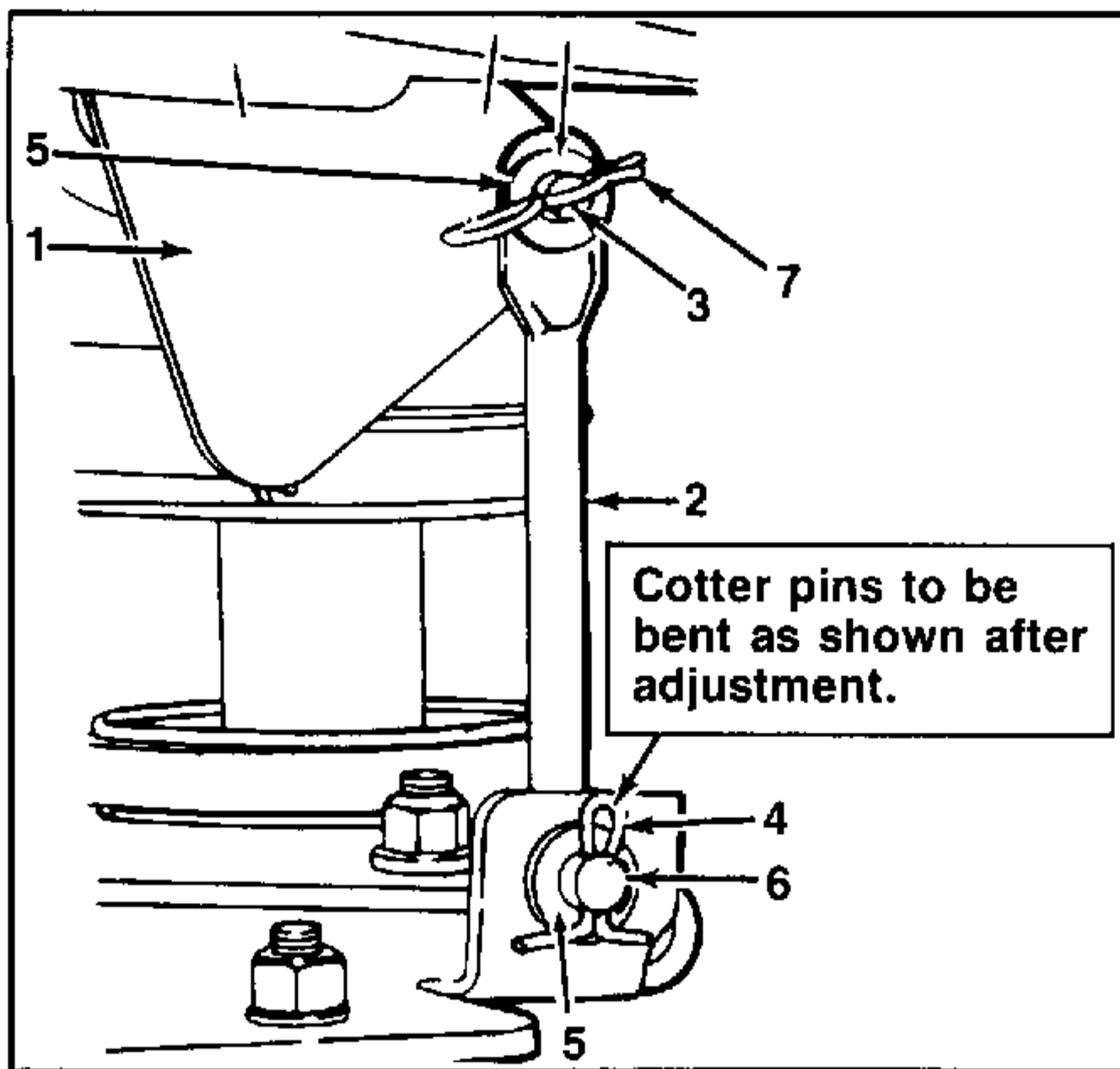

FIGURE 4.

- | | |
|-------------------|-------------------|
| 1. Lift Carriage | 5. Flat Washer |
| 2. Rear Lift Link | 6. Ferrule |
| 3. Lift Pin | 7. Hairpin Cotter |
| 4. Cotter Pin | |

4. Remove the deck hanger rod flat washer and hairpin cotter. Refer to figure 1.
5. Raise the lift handle to its highest setting. Refer to figure 5 and place the deck on the right side of the tractor, with the front of the deck facing toward the front of the tractor. Slide the deck under the tractor until it is aligned with the tractor as illustrated in figure 6.

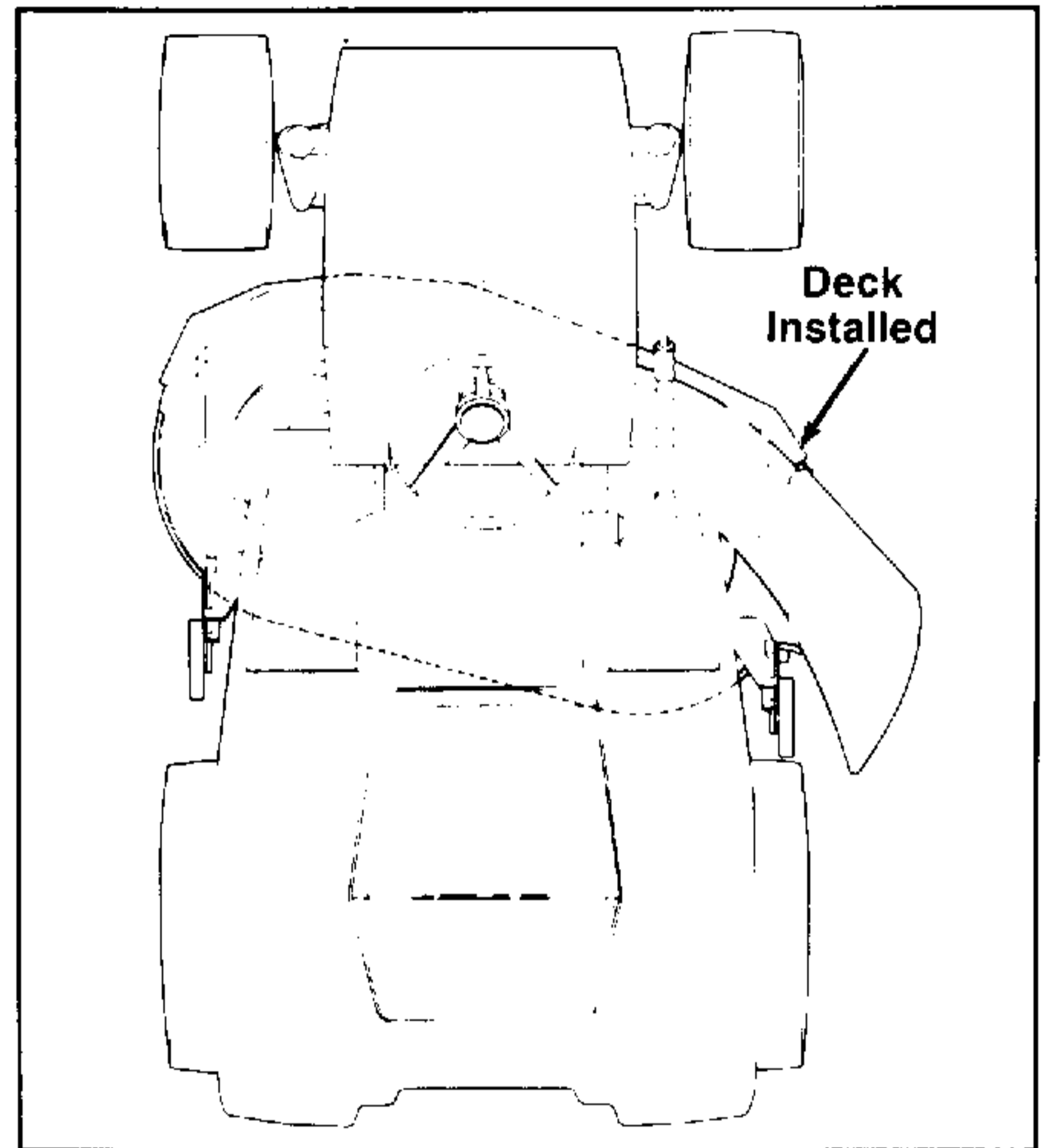

FIGURE 6.

6. Refer to figure 7. Lift the front end of the deck, and set the outside spindle nut on the face of the six inch long 2 x 4 inch wooden block (obtained from a wooden building stud). Repeat this step for the left spindle.

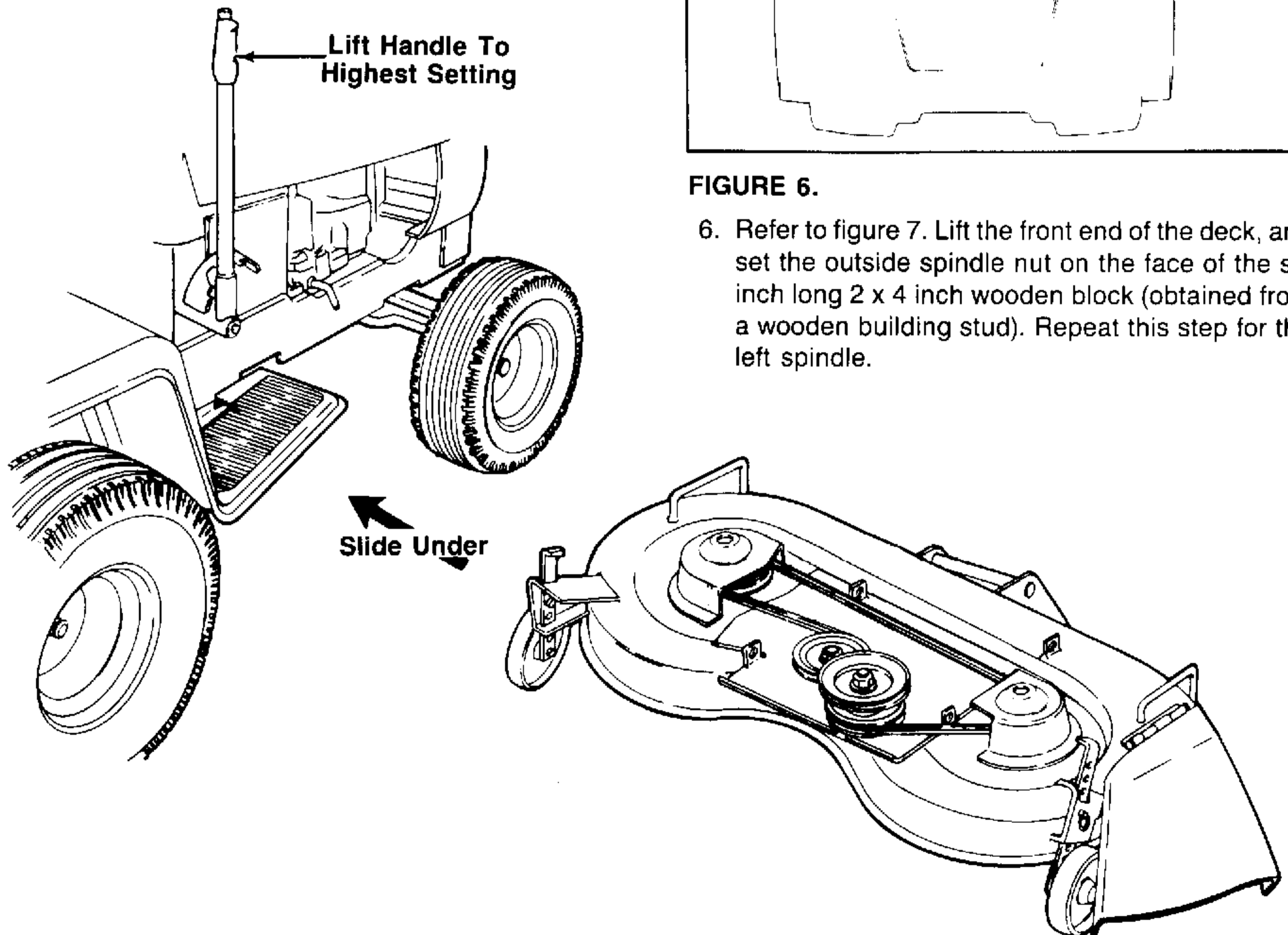

FIGURE 5.

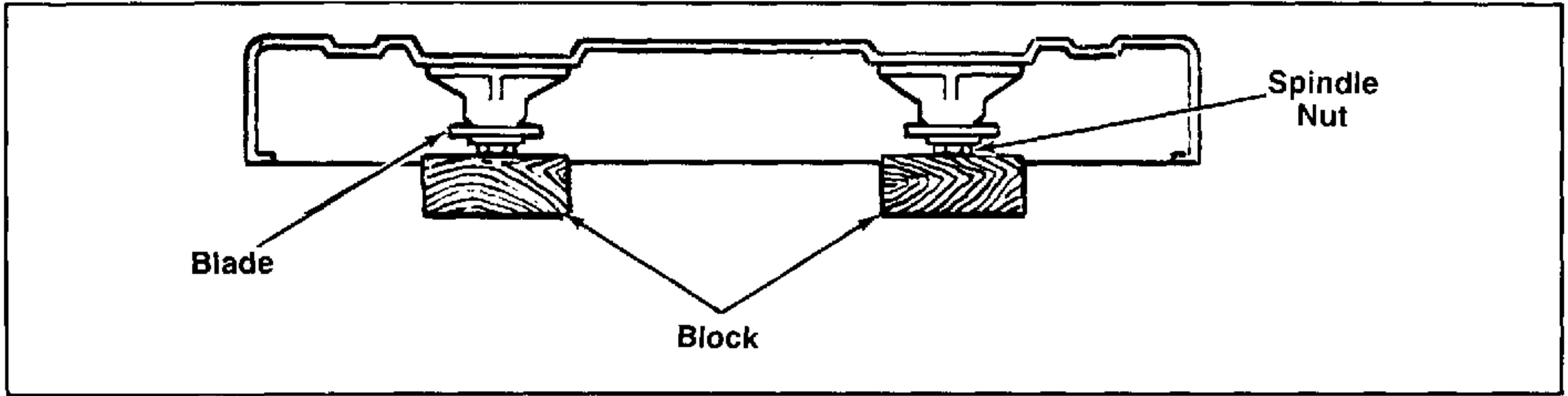

FIGURE 7.

7. Place the lift handle in position number 1. Screw a ferrule onto each of the rear lift links. Secure each of the rear lift links to the lift carriage lift pins using a flat washer and cotter pin.
8. Adjust the ferrules on the rear lift links so that the small end of the ferrule lines up with the hole in the deck lift bracket. When performing this step **recall the relative position of the right rear ferrule to the deck lift bracket**. Secure each of the rear ferrules to the deck lift brackets using a flat washer and a cotter pin.
9. Screw on and position ferrules to the front lift links.

10. Refer to figure 8 and secure the links to the front deck brackets with flat washers and cotter pins.
10. Refer to figure 9 to determine the proper positioning of the front hanger assembly in relation to the tractor and deck. Note that when the front hanger assembly is properly positioned, the hanger extensions face the rear of the tractor, and the top of the front hanger assembly is open. Attach the rear of the front hanger assembly to the top hole of the front roller bracket using the deck hanger rod. Secure the rod to the bracket using a flat washer and hairpin cotter.

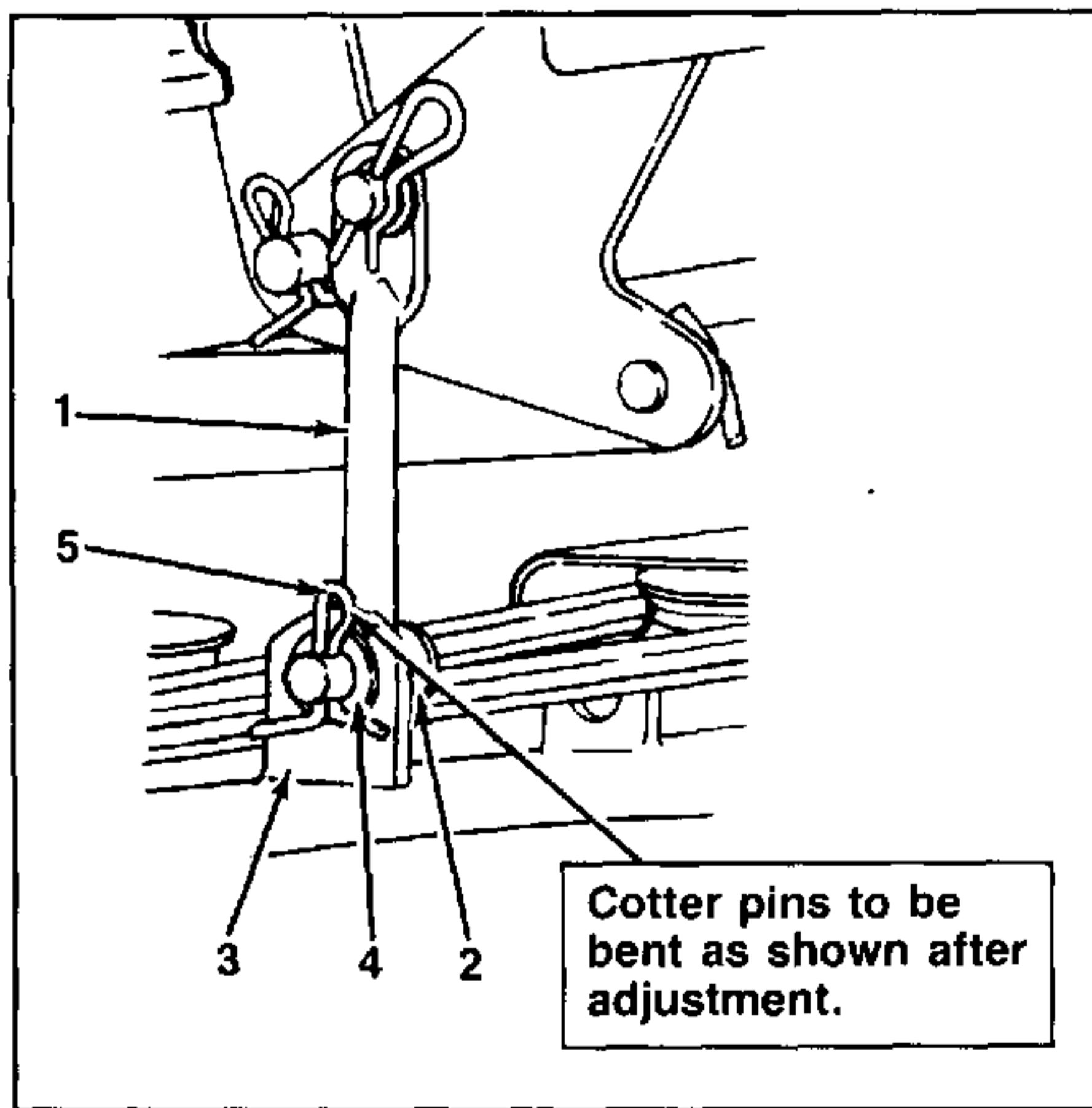

FIGURE 8.

1. Front Lift Link
2. Ferrule
3. Front Deck Lift Bracket
4. Flat Washer
5. Cotter Pin

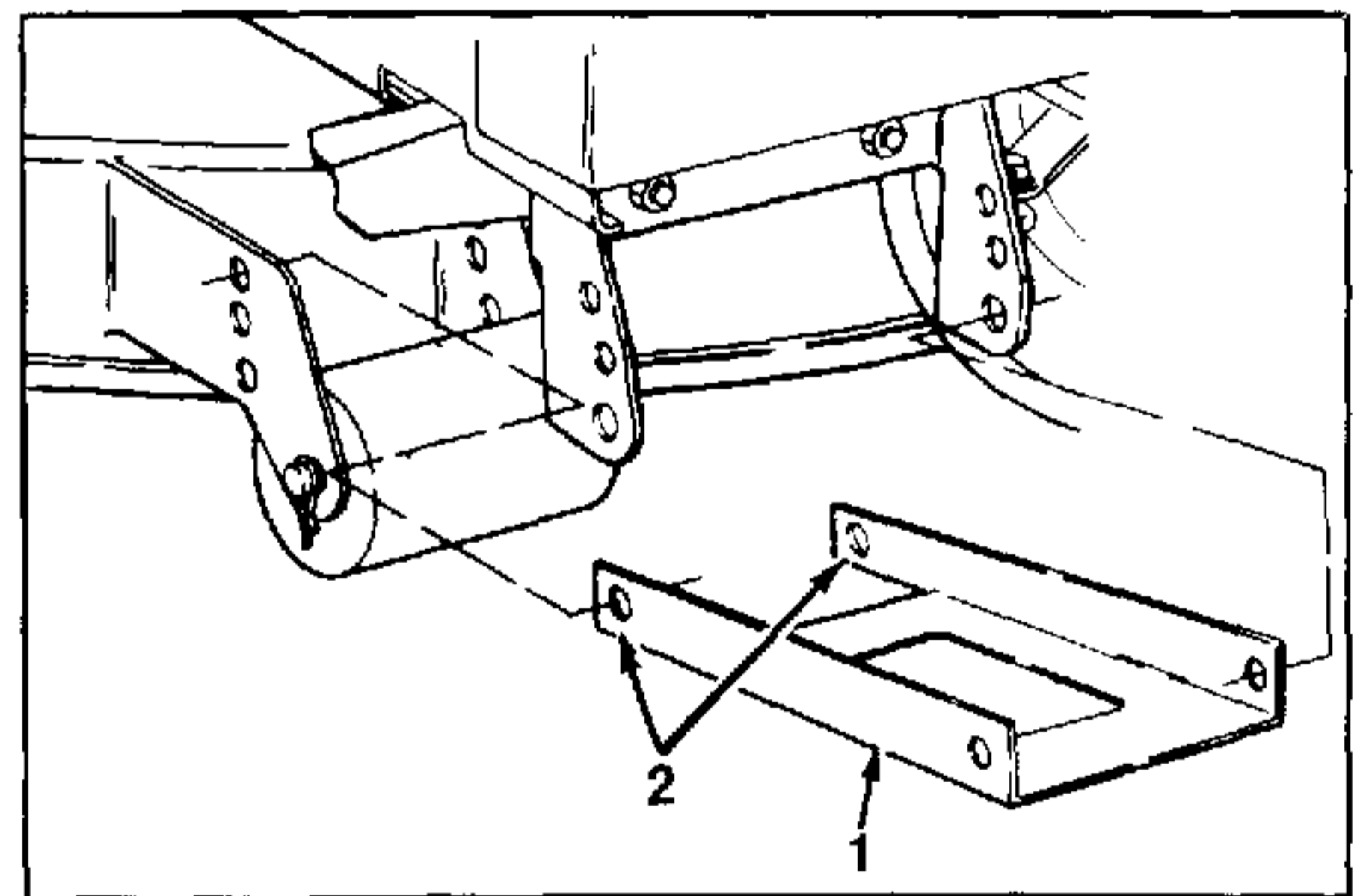

FIGURE 9.

1. Front Hanger Assembly
2. Hanger Extension
11. With the left front wheel turned to the left, attach the front hanger assembly to the front hanger bracket by passing the tractor hanger rod through the bottom mounting holes of the front hanger bracket. Remember to attach the central flat washer to the rod after it passes through the right side of the front hanger assembly. Refer to figure 10. Secure the tractor hanger rod with flat washer and hairpin coppers.

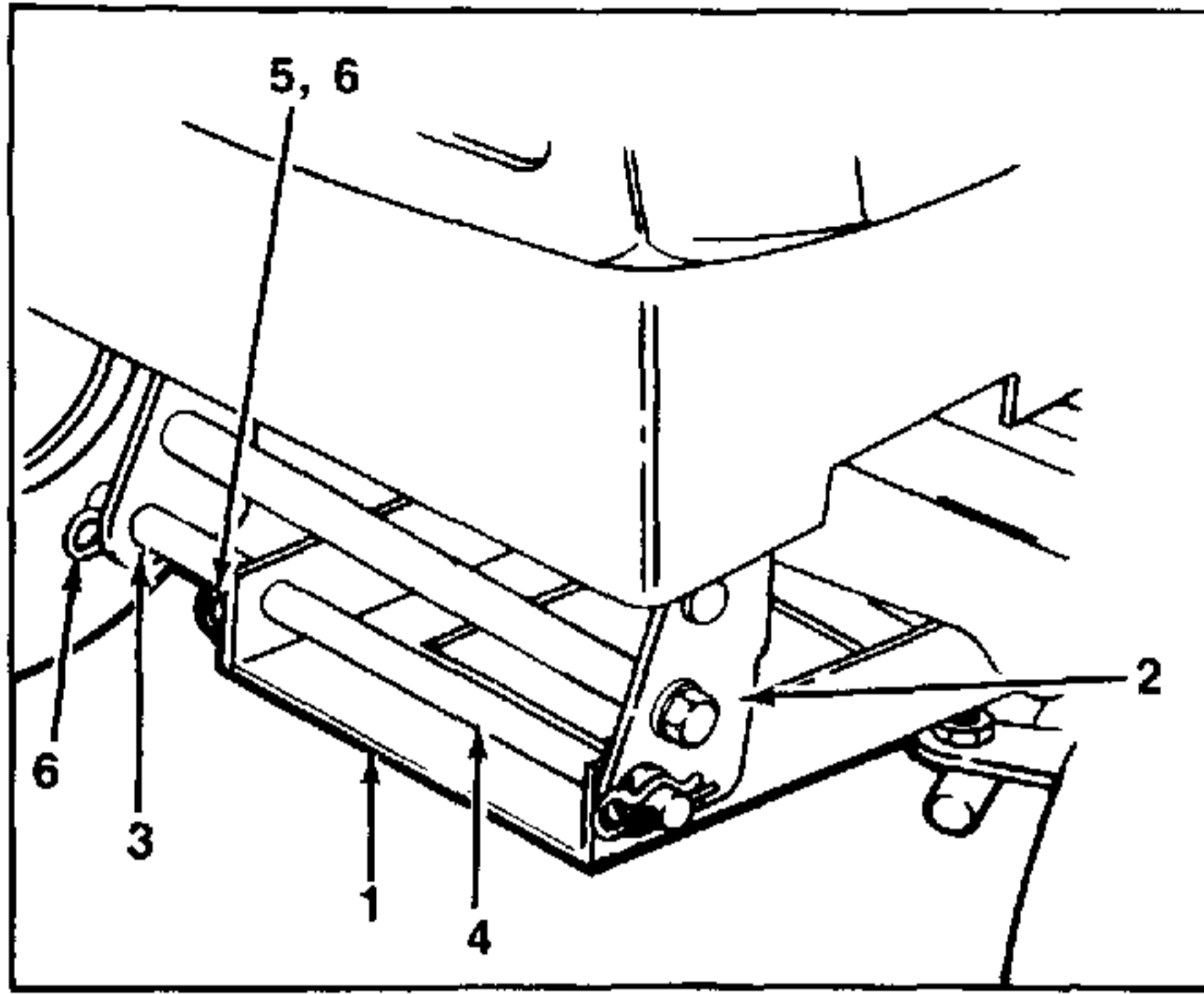

FIGURE 10.

1. Front Hanger Assembly
2. Front Hanger Bracket
3. Bottom Mounting Hole
4. Tractor Hanger Rod
5. Central Flat Washer
6. Hairpin Cotter

12. Install front PTO drive belt on upper pulley of double drive pulley on deck.
13. Slip drive belt over electric PTO pulley on tractor. Refer to figure 11.

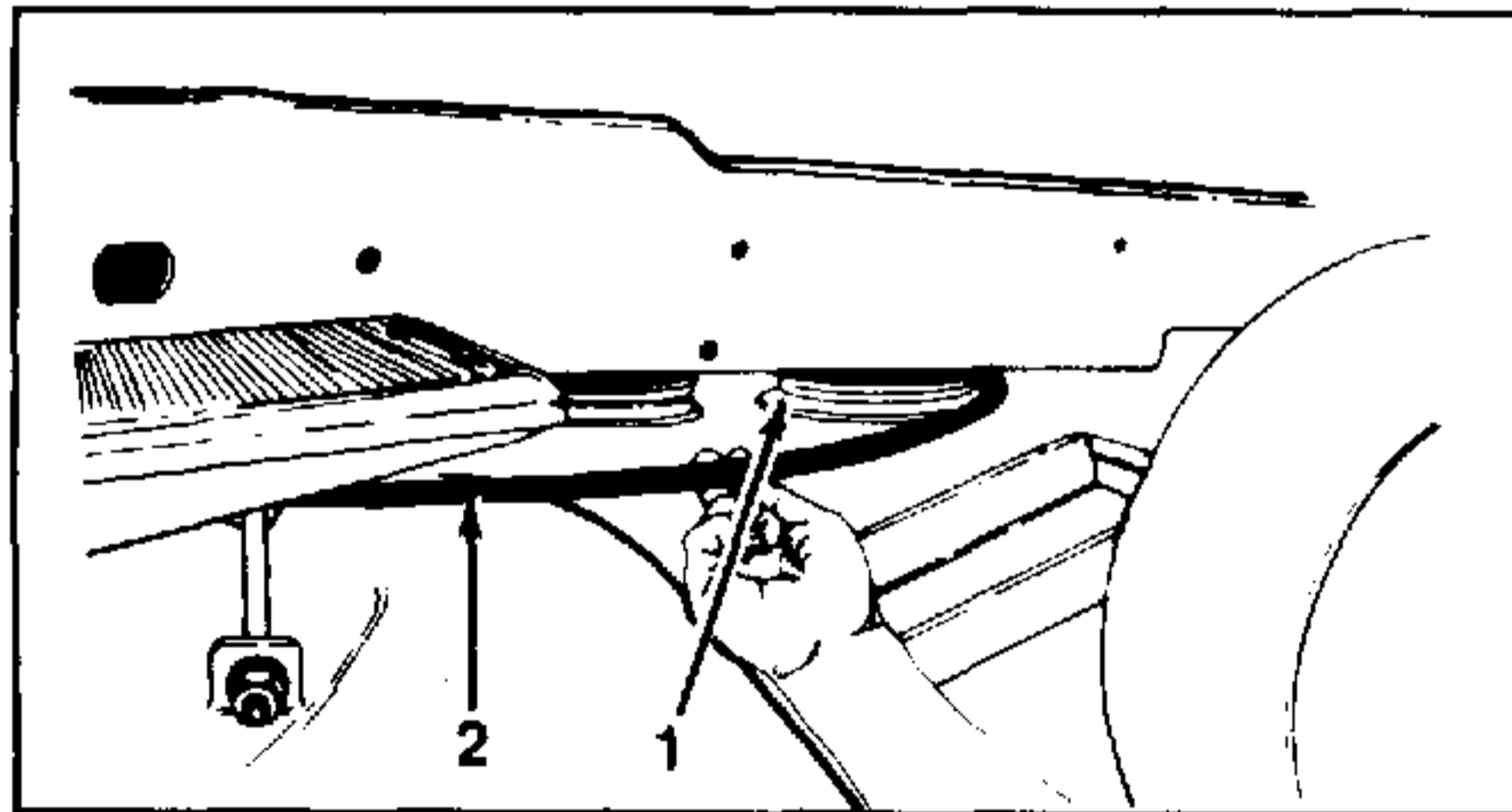

FIGURE 11.

1. Electric PTO Pulley
 2. Front PTO Drive Belt
14. Pull idler pulley away from the tractor and then place drive belt behind it. Release idler pulley. Refer to figure 12.

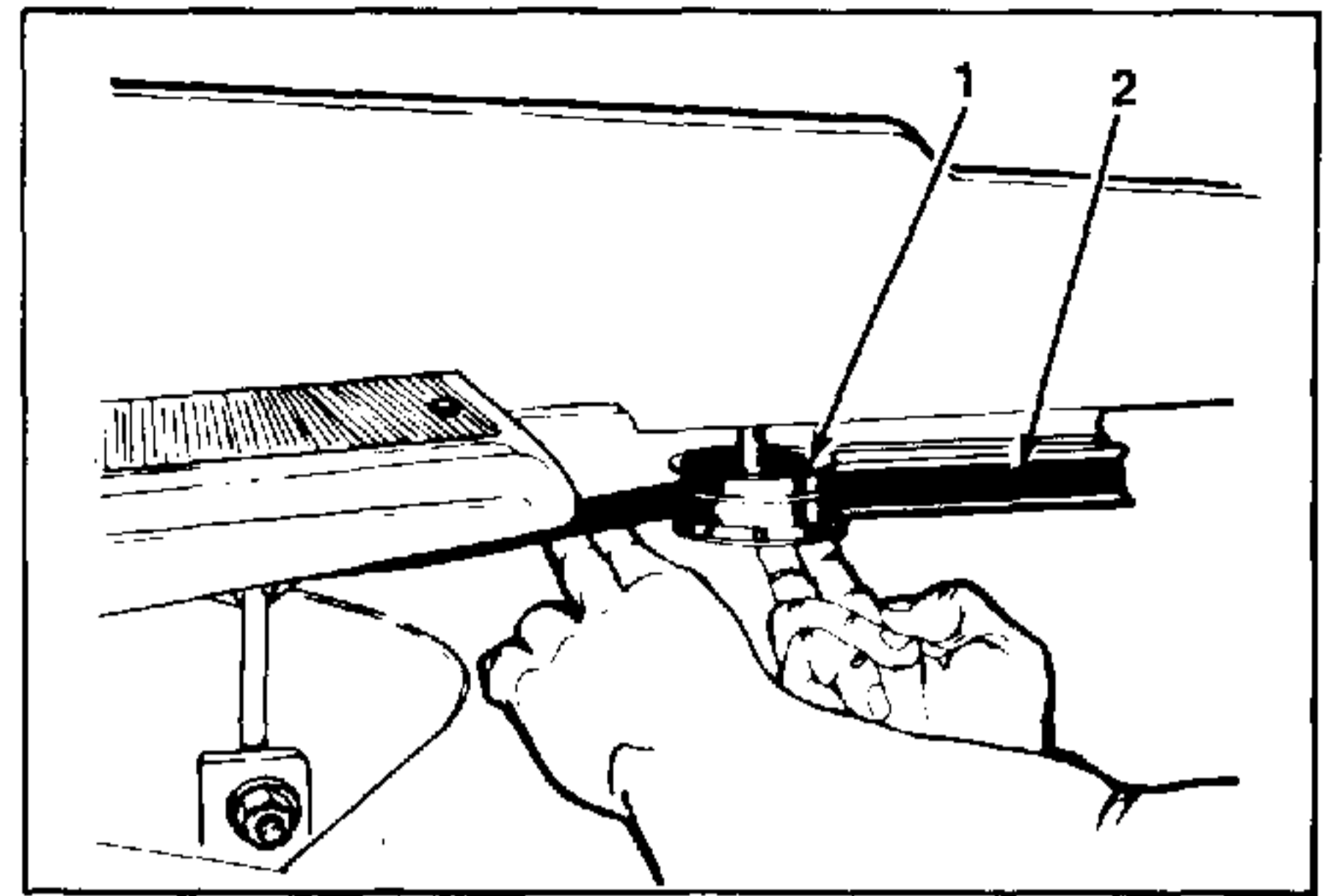

FIGURE 12.

1. Idler Pulley
2. Front PTO Drive Belt

C. REMOVAL OF DECK



WARNING

Stop the tractor engine, disengage the PTO, place all controls in neutral and engage the parking brake before performing deck removal.



WARNING

When handling the mower deck, be careful not to cut yourself on the sharp blades.



CAUTION

The mower deck must be placed on a hard level surface during removal.



CAUTION

Be careful not to hit the hydrostatic linkage with the wheel adjustment brackets when sliding the deck in or out.

Removal of the deck is achieved by reversing the deck installation procedure described under "INSTALLATION OF DECK" detailed on page 3-20.

SECTION III. ADJUSTMENTS

A. DECK LEVELING ADJUSTMENTS

In order to achieve even cutting, the mower deck must be properly leveled. This leveling procedure will result in the left and right blades having corresponding front cutting-edge-to-ground measurements within 1/16 inch. Also, the right and the left blades will each have a 1/16 to 1/8 inch downward tilt toward the front of the tractor. Proceed as follows:



WARNING

Before making any adjustments, turn off the machine, remove the key, and engage the brake pedal lock to avoid accidental starting and injury.



WARNING

When adjusting the mower deck, be careful not to cut yourself on the sharp blades.



CAUTION

If the mower deck is not level, the mower will not cut your lawn evenly.



NOTE

Check the tires for proper inflation before making a level adjustment. To level the deck, the tractor **MUST** be placed on a hard, level surface.

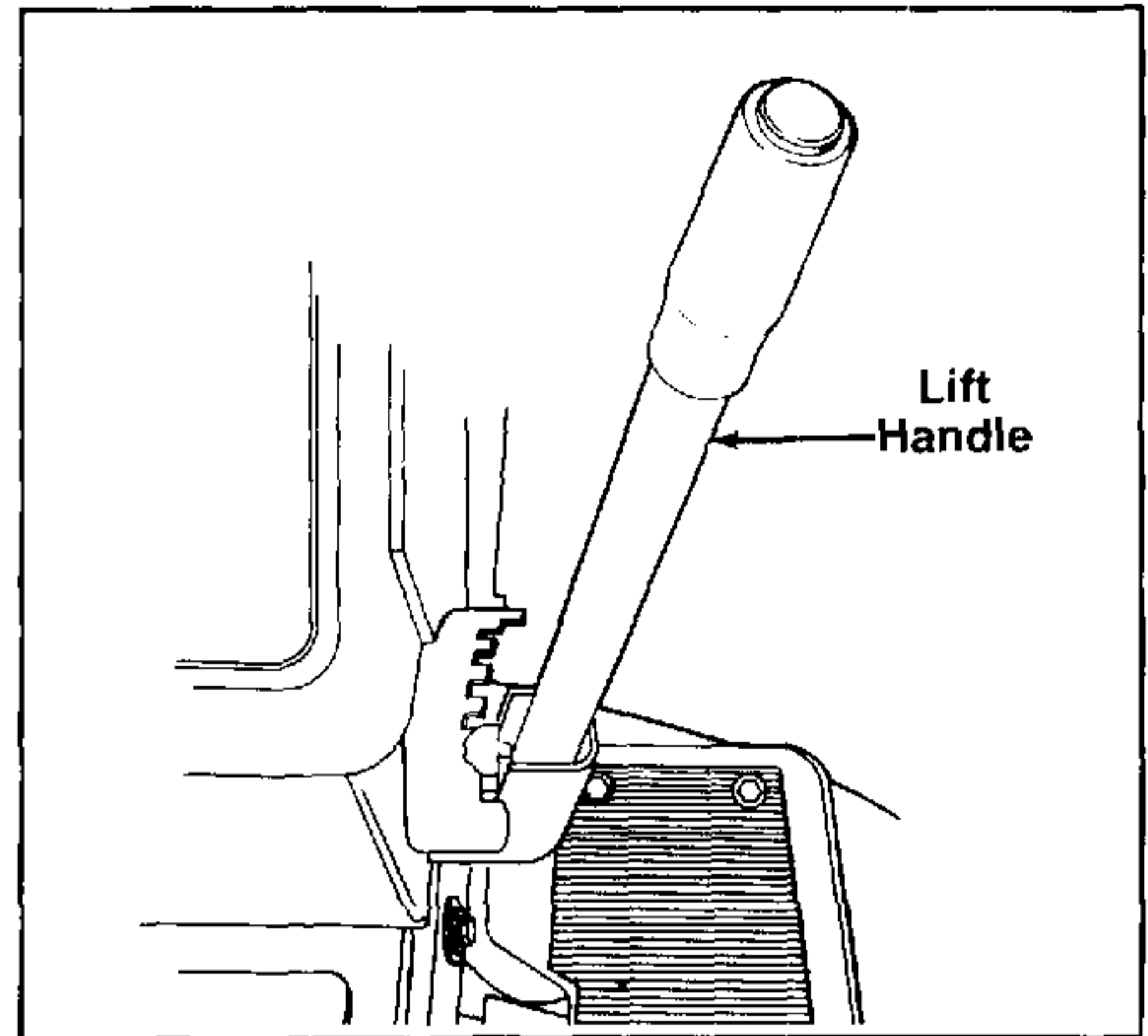

FIGURE 13.

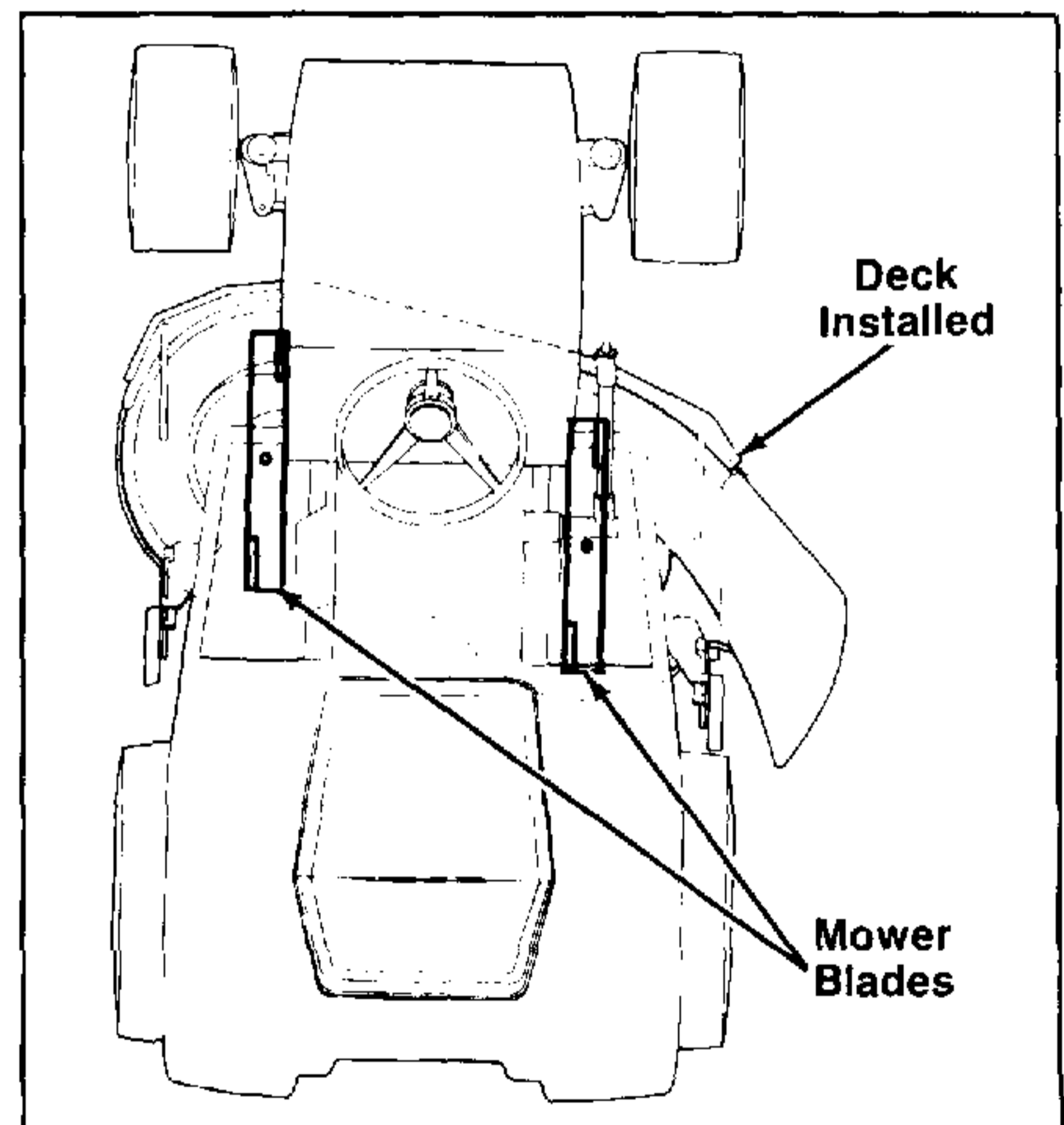

FIGURE 14.

1. The gauge wheels should be set to the lowest position as described in **GAUGE WHEEL** of Section III located on page 3-15.
2. Place the lift handle (figure 13) in position number 6.
3. Disconnect the spark plug wire(s).
4. Position the mower blades so that the ends of each blade face the front and rear of the tractor. Refer to figure 14.
5. Refer to figure 15. Measure and record the distance from the hard, level surface to the **CUTTING EDGE** at the front and rear of each of the blades. Hereafter, these measurements will be referred to as the cutting-edge-to-ground distances.

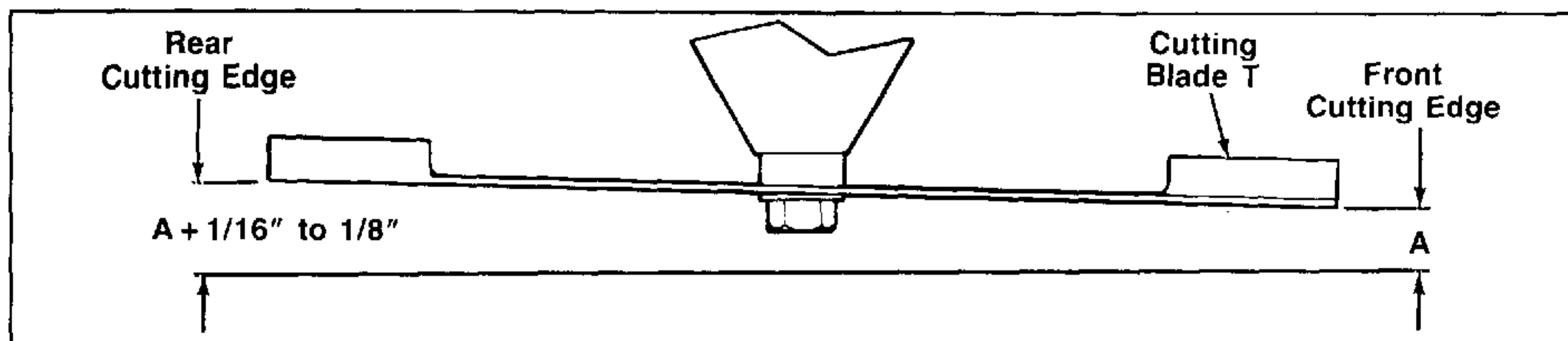

FIGURE 15.

6. Determine which blade has the highest front cutting-edge-to-ground distance. Adjustments designed to place the front cutting-edge-to-ground measurements of the two blades within 1/16 inch of one another are performed on the blade which has the highest recorded front cutting-edge-to-ground measurement.
7. Begin by placing the lift handle in position number one. Remove the hairpin cotter and flat washer which secure the front lift link to the lift carriage lift pin. Refer to figure 8. Remove the front lift link from the lift carriage lift pin.
8. Turn the lift link counterclockwise (out of the ferrule), until the front cutting-edge-to-ground distance on the high blade is equal to the corresponding blade measurement on the opposite side of the deck. Each 360 degree turn of the lift link equals approximately 1/16 inch.
9. Reposition the front lift link onto the lift carriage lift pin, and secure with a flat washer and hairpin cotter.
10. Place the lift handle in position number 6, and remeasure the front cutting-edge-to-ground distance on the high blade. If it is within 1/16 inch of the corresponding measurement on the opposite blade, proceed to step 11. If the two measurements are not within 1/16 inch, repeat steps 6, 7, 8, 9, and 10 until the desired measurement is achieved.
11. With the lift handle in position number 6, repeat and record the blade measurements described in step 5. Refer to your recorded cutting-edge-to-ground measurements. Each of the two blades must have a downward tilt toward the front of the tractor. A proper tilt is achieved when a blade's rear cutting-edge-to-ground measurement (measurement A + , figure 15) is 1/16 to 1/8 inch higher than that blade's front cutting-edge-to-ground measurement (measurement A, figure 15). If a proper tilt does not exist for one or both of the blades, refer to step 12.
12. Place the lift handle in position number 1. Working on side of the deck corresponding to the blade being adjusted. Refer to figure 4, and remove the

hairpin cotter and flat washer securing the rear lift link to the lift carriage lift pin. Remove lift link from the lift pin.

13. Rotate the lift link into or out of the ferrule to achieve the 1/16 to 1/8 inch downward tilt of the blade. Each 360 degree rotation of the lift link equals approximately 1/16 inch. Clockwise rotation of the lift link increases the tilt; counterclockwise rotation decreases the tilt.
14. Reposition the rear lift link onto the lift carriage lift pin. Secure with a flat washer and hairpin cotter.
15. Place the lift handle in position number 6. Remeasure the front and the rear cutting-edge-to-ground distances to confirm that the proper blade tilt, as described in step 11, has been achieved. If the proper tilt has not been achieved, repeat steps 11, 12, 13 and 14.

B. GAUGE WHEELS

➡ NOTE

Gauge wheel adjustment should be done only AFTER the deck has been properly installed.

In order to adjust the height of the gauge wheels, proceed as follows:

1. Pull out the quick release pin.
2. With pin pulled out, slide the gauge wheel bracket up or down until desired height is reached.
3. Reinsert the quick release pin.

➡ NOTE

There are half height adjustment holes along with the adjustment holes in the gauge wheel bracket. Both gauge wheels must be set in the same relative hole locations. Refer to figure 16.

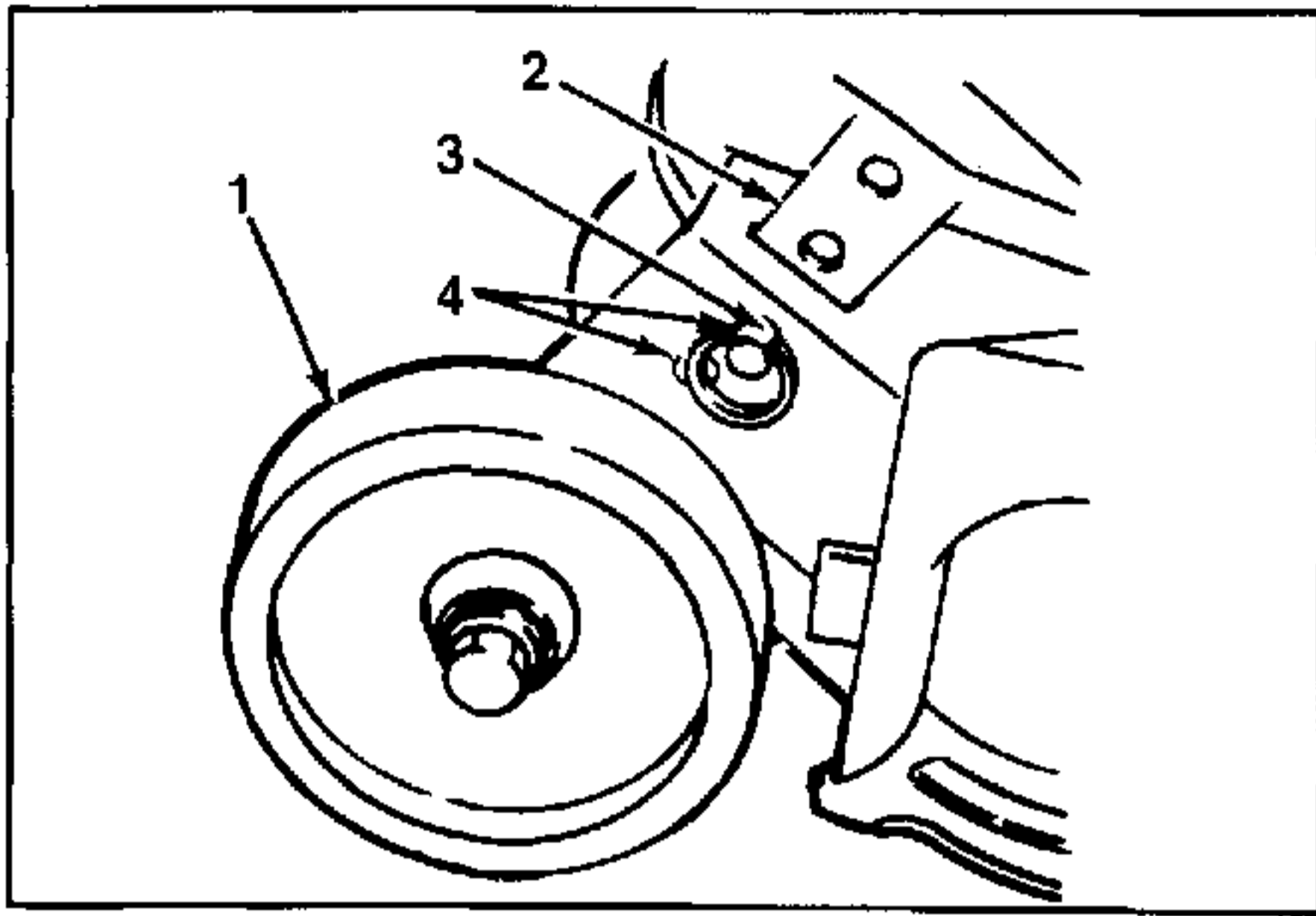

FIGURE 16.

1. Gauge Wheel
2. Gauge Wheel Bracket
3. Quick Release Pin
4. Half Height Adjustment Holes

C. CUTTING HEIGHT

The mower can be set in multiple positions. Proceed as follows:

1. Pull the lift handle back slightly and depress the button on the top of the lift handle.
2. Release the button when the desired mower position is obtained.

➔ NOTE

To return the mower to a specific position, note position of the lift lever indicator in relation to the lever position decal before raising or lowering the mower.

SECTION IV. MAINTENANCE

A. CLEANING AND BLADE CARE



WARNING

Stop the tractor, disengage the PTO, place all controls in neutral, engage the parking brake lock and stop the engine before performing any maintenance.



WARNING

Be careful not to cut yourself when sharpening the blades or cleaning the underside of the mower.

Clean the underside of the mower deck at the end of the mowing season and when buildup of cut material on the underside is noticed. Also remove the belt cover and remove any accumulation.

The cutting blades must be kept sharp at all times.

➔ NOTE

Sharpen ends evenly so that the blades remain balanced and the same angle of sharpness is maintained. However, if the cutting edge of a blade has been sharpened to within 3/8 inch of the wind wing, it is recommended that new blades be installed. New blades are available at your authorized dealer.

When removing the blades, hold the hex shaped pulley hub with a 1 1/4 inch socket wrench to remove the hex nut holding the blade. A block of wood may be placed between housing and cutting edge of blade to assist in removal of hex nut securing blade. Refer to figure 17.

After replacing blades, grease the threaded end of the shaft to prevent rust buildup.

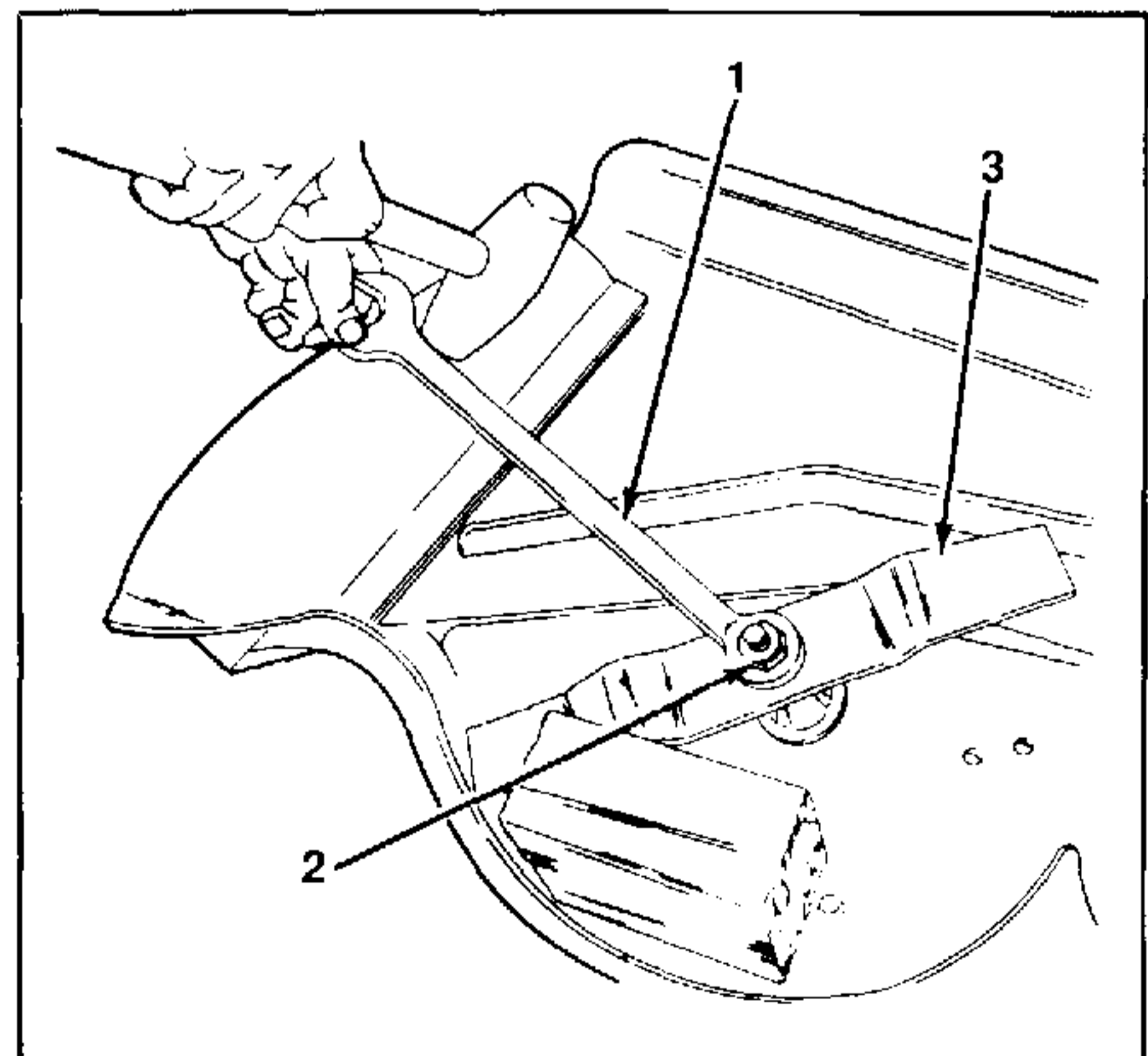

FIGURE 17.

1. 1-1/8 Inch Wrench
2. Hex Nut
3. Blade

When replacing the blades, be sure they are assembled so the cutting edges are in the direction of rotation with the wind wings pointed upward. Tighten the nuts 50 to 60 ft.-lbs. (68 to 81 N.m).

NOTE

If the spindle pulley nuts are removed for any reason, they should be retightened to 90 to 110 ft.-lbs. (122 to 149 N.m) torque when replaced.

B. LUBRICATION

After every 50 hours of operation and/or before putting into winter storage, lubricate the spindle assemblies using 251H EP grease or equivalent No. 2 multipurpose lithium grease. The grease will be expelled from the top spindle seal. Since the spindle pulley covers the top spindle seal, the expelled grease cannot be seen. When the spindle is fully greased, the expelled grease will cause the top spindle seal to give off a muffled crackling noise. Refer to figure 18.

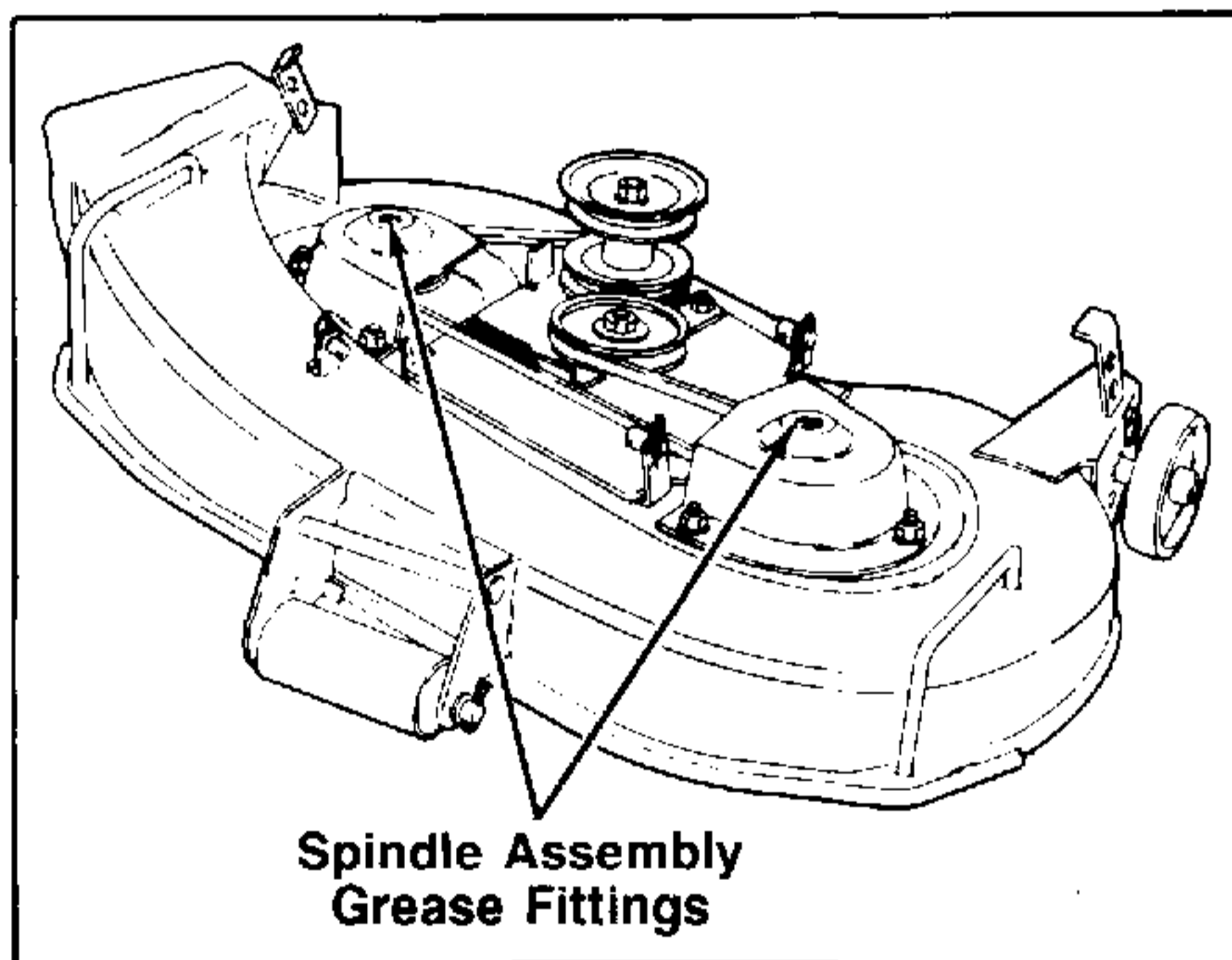

FIGURE 18.

C. SPINDLE DRIVE BELT REPLACEMENT

In order to replace the spindle drive belt, refer to figure 19, 20 and 21 and proceed as follows:

1. Remove the nuts and washers that secure both spindle belt covers to the deck.
2. Remove the spindle belt covers to expose the belt.
3. Push against the idler pulley to release tension on drive belt.
4. Remove old drive belt.
5. Install a new belt. Refer to figures 19, 20 and 21 for proper placement of belt. Push against idler pulley to aid the installation.
6. Reinstall spindle belt covers and hardware.

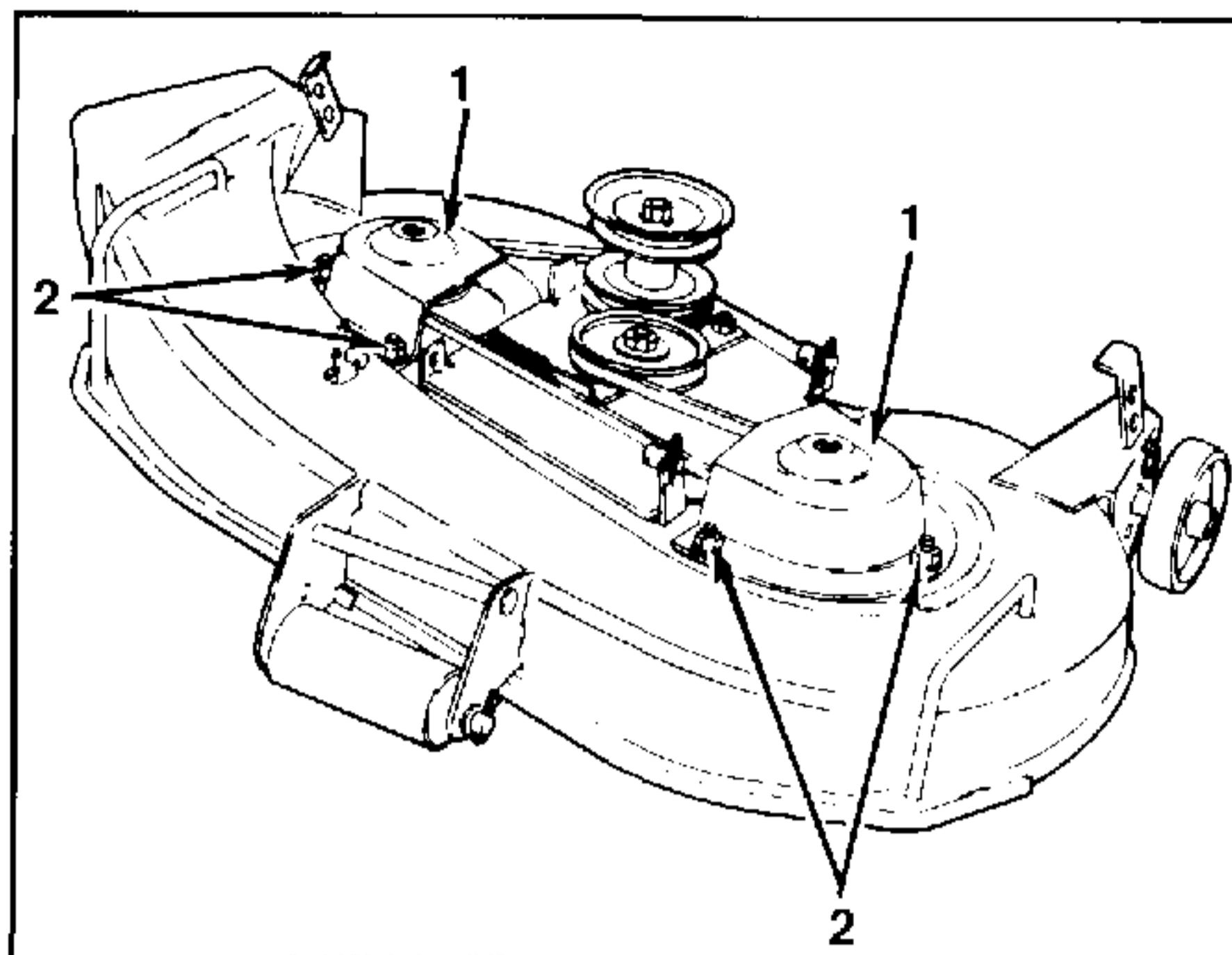

FIGURE 19.

1. Spindle Belt Cover
2. Nuts and Washers

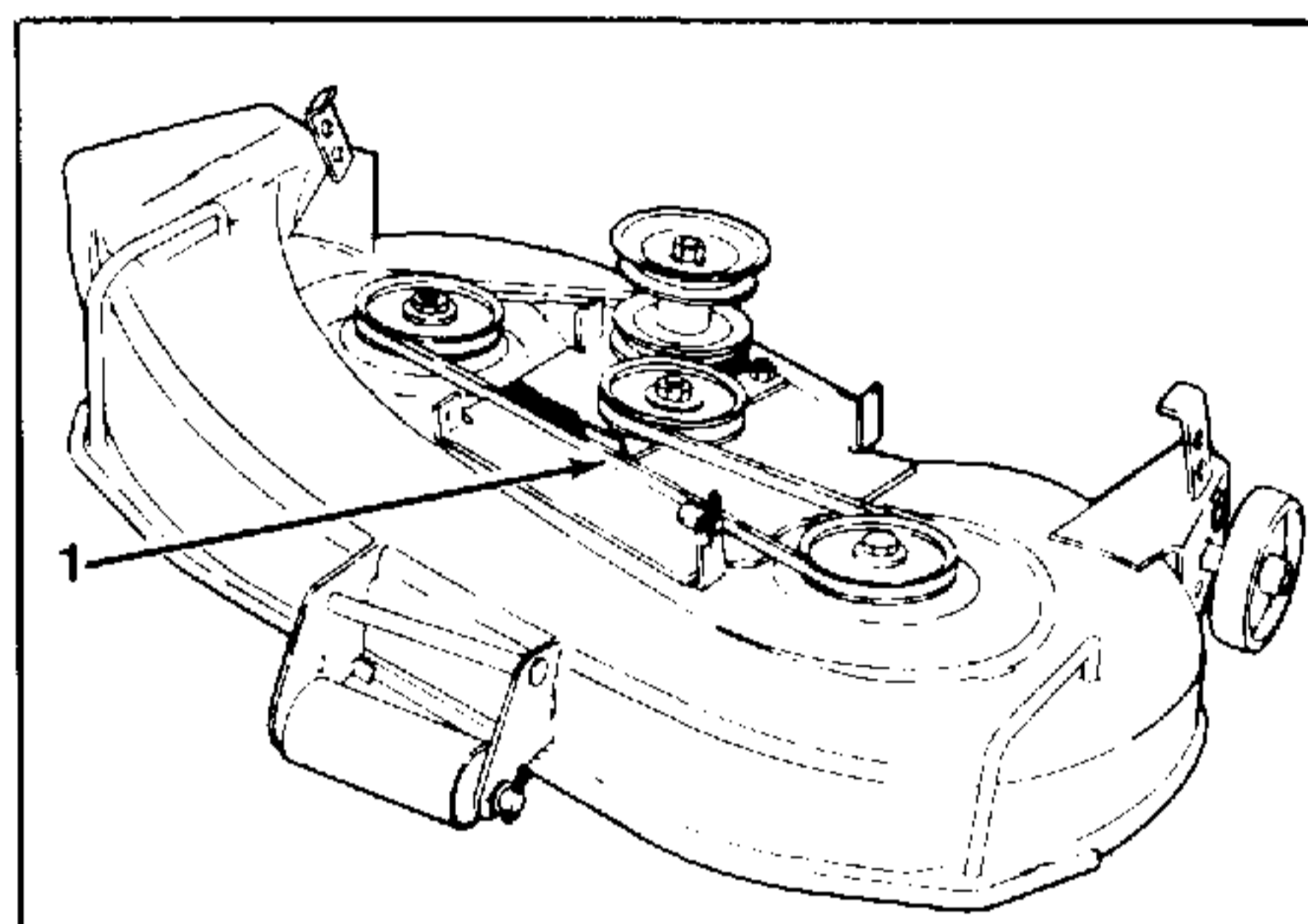

FIGURE 20.

1. Spindle Drive Belt

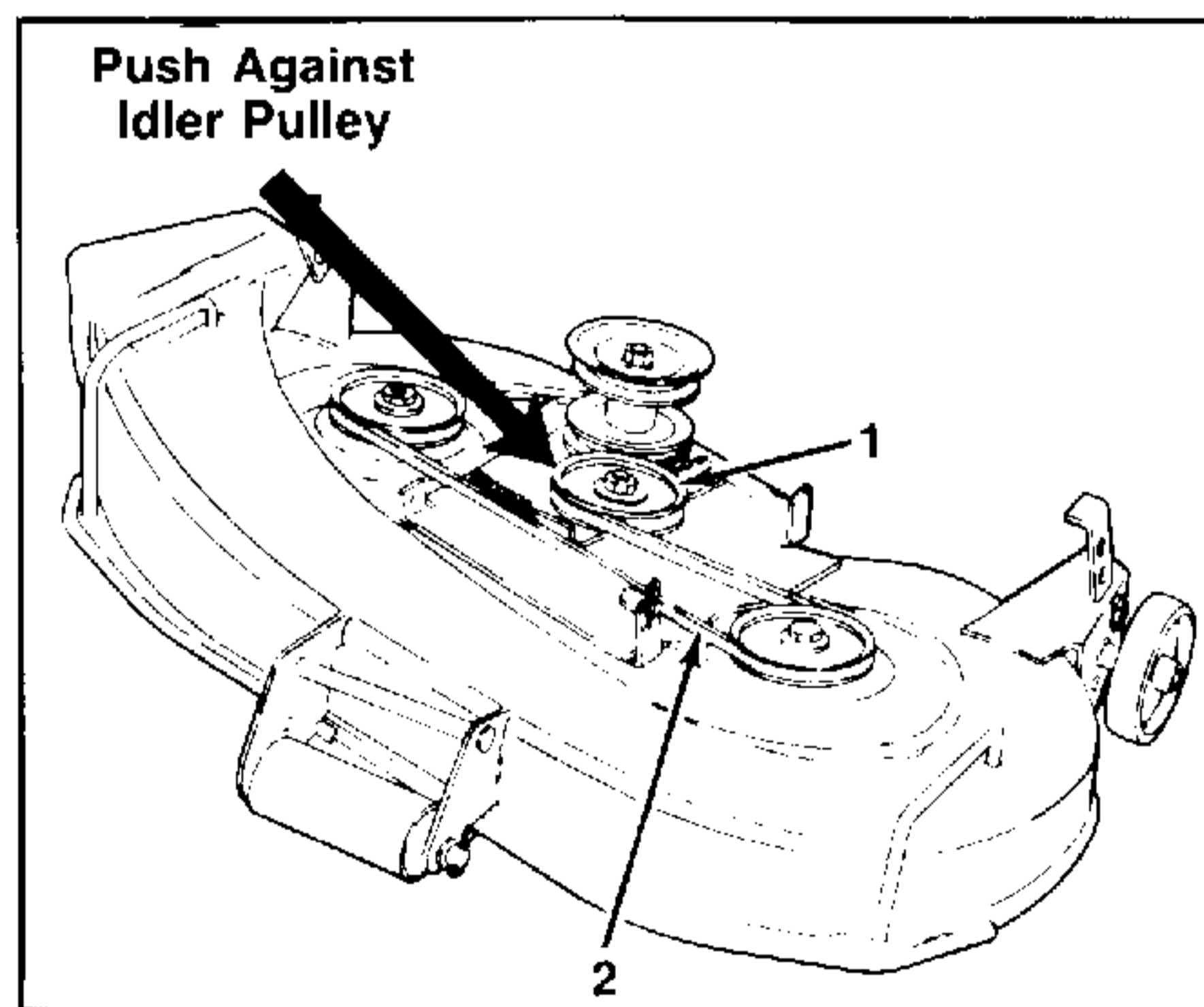

FIGURE 21.

1. Idler Pulley
2. Spindle Drive Belt

LUBRICATION GUIDE

The life of any machine depends upon the care it is given. Proper lubrication is a very important part of that care.

Be certain that all lubrication fittings are assembled in place, using the lubrication illustrations as a guide.

Always lubricate the deck thoroughly before taking it to the field. Use a pressure lubricating gun.

Be sure all fittings are free from dirt and paint so the lubricant is certain to enter the bearing.

Always force the lubricant through the full length of each bearing until it emerges at the end, carrying with it the worn lubricant and any dirt that may have entered the bearing.

Miscellaneous working parts not provided with lubrication fittings should be oiled daily with a good grade of lubricating oil.

Lubricant is cheap. Use plenty of it. Worn parts can be expensive to replace.

Keep your supply of lubricating oil and grease stored in clean containers, and covered to protect from dust and dirt.

Keep the lubricating gun nozzle clean and wipe dirt from grease fittings before lubricating.

The symbol in the illustration indicates the method of application and the hourly intervals to apply the lubricant.

Use a pressure lubricating gun and apply 251H EP grease (or equivalent No. 2 multipurpose lithium grease) sufficient to flush out the old grease and dirt. Lubricate at hourly intervals indicated on symbol.

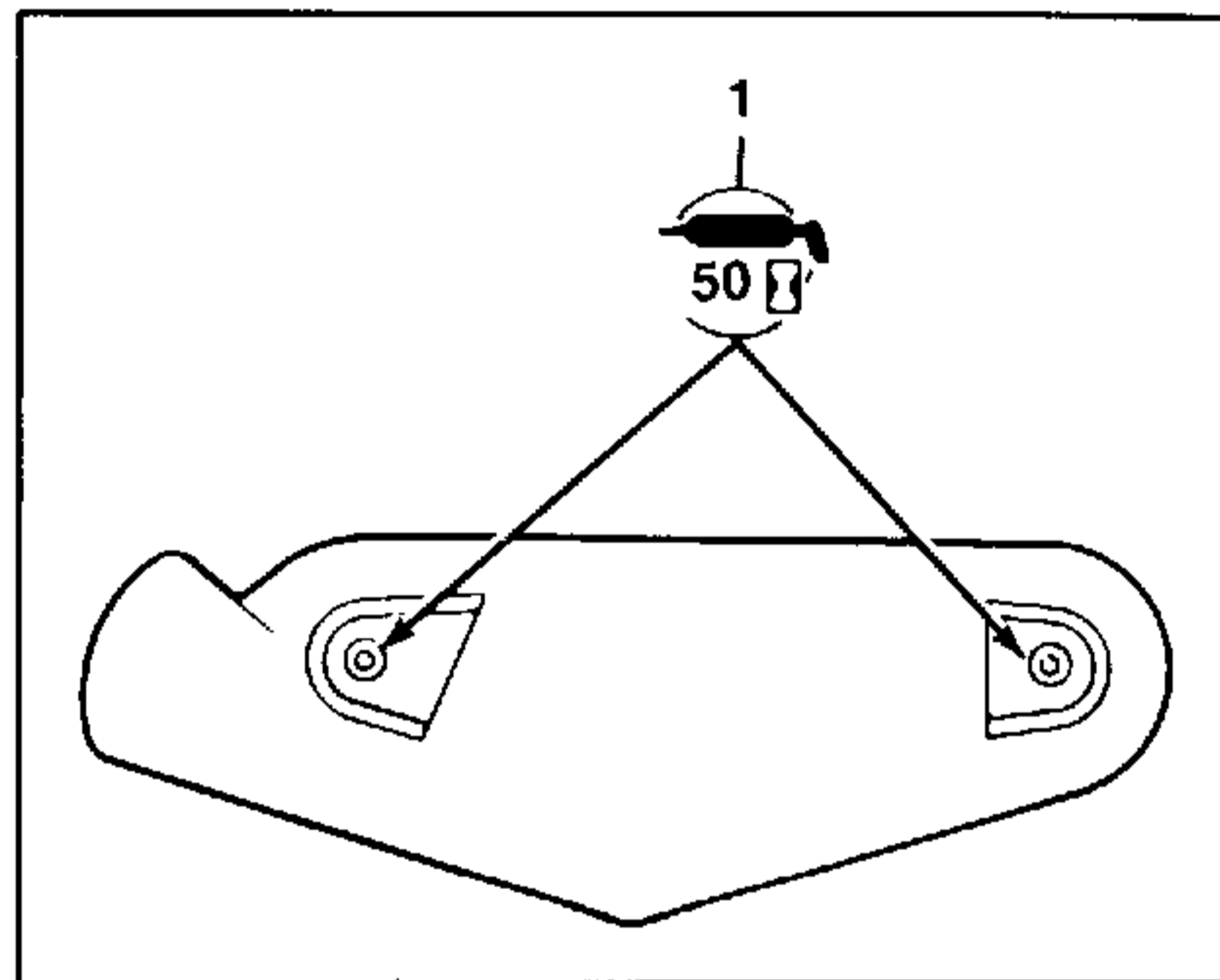

(38 Inch Deck)

1. Deck Spindles

—EVERY 50 HOURS OF OPERATION

Use 251H EP grease or equivalent No. 2 multipurpose lithium grease and apply sufficient grease to flush out old grease and dirt.

MOWING DECK— ADJUSTMENTS AND OPERATION MODEL 331

SECTION I. DECK ASSEMBLY COMPONENTS



WARNING

When handling the mower deck, be careful not to cut yourself on the sharp blades.

Remove deck components from the container. Refer to figure 1 to ensure that all parts are present and to acquaint yourself with parts nomenclature.

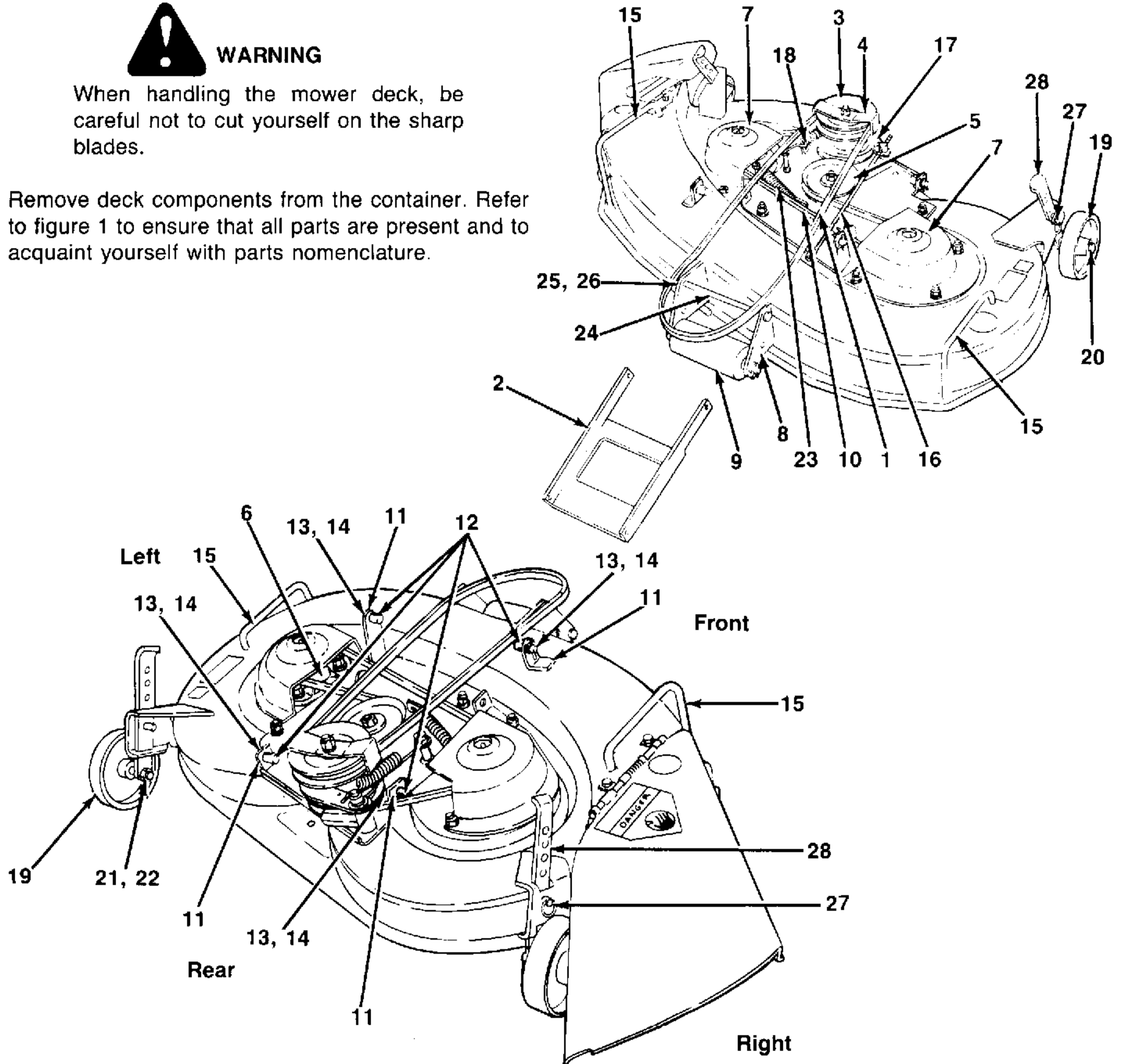

FIGURE 1.

- | | | |
|-----------------------------------|----------------------------|-----------------------|
| 1. Front PTO Drive Belt | 11. Lift Bracket | 21. Hex Nut |
| 2. Front Hanger Assembly | 12. Ferrule | 22. Lock Washer |
| 3. Double Drive Pulley | 13. Cotter Pin | 23. Idler Spring |
| 4. Double Drive Pulley Belt Guard | 14. Flat Washer | 24. Deck Hanger Rod |
| 5. Flat Idler Pulley | 15. Handle | 25. Flat Washer |
| 6. Spindle | 16. Brake Rod | 26. Hairpin Cotter |
| 7. Blade Spindle Belt Covers | 17. Brake Bracket Assembly | 27. Quick Release Pin |
| 8. Front Roller Bracket | 18. Deck Brake Spring | 28. Gauge Wheel |
| 9. Front Roller | 19. Gauge Wheel | Adjustment Bracket |
| 10. Spindle Drive Belt | 20. Shoulder Bolt | |

SECTION II. TRACTOR PREPARATION



WARNING

Stop the tractor engine, place the PTO engagement lever in the "OFF" position, place all controls in neutral and engage the brake pedal lock before performing tractor preparation.

Remove the tractor hanger rod. Refer to figure 2. Using the steering wheel, turn the left front wheel to the left as far as possible. Remove the hairpin cotters from the right end and from the center of the tractor hanger rod. Withdraw the rod from the front hanger bracket. Collect the washers.

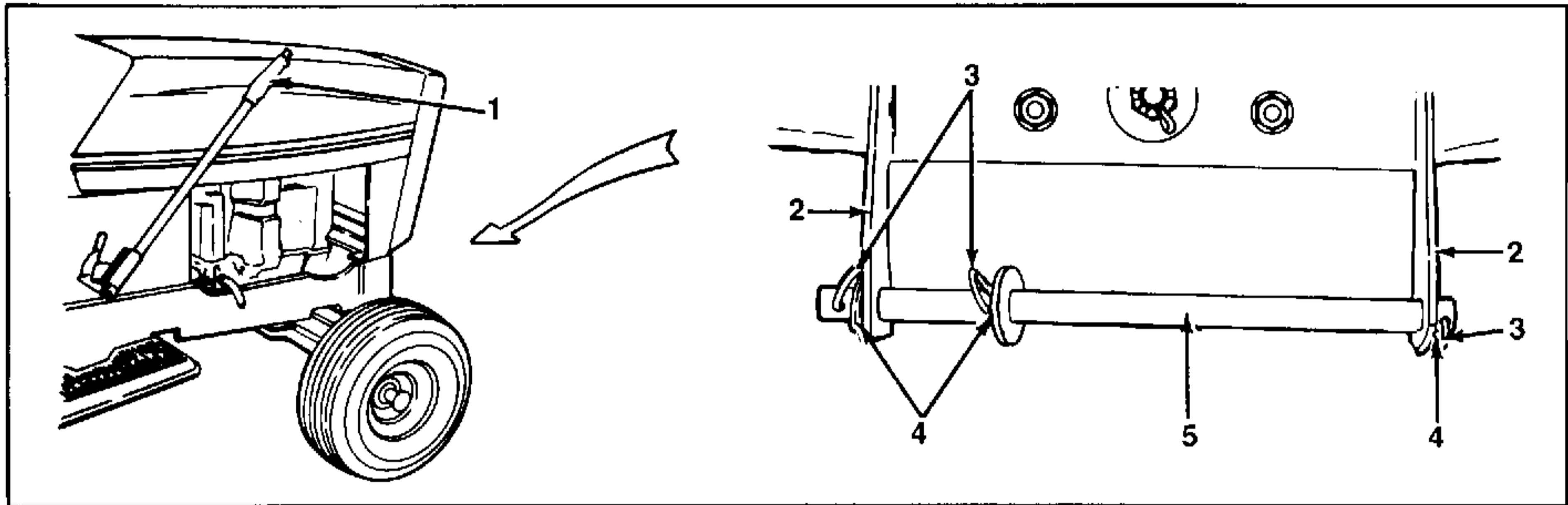

FIGURE 2.

1. Lift Handle
2. Front Hanger Bracket
3. Hairpin Cotter

4. Flat Washer
5. Tractor Hanger Rod

SECTION III. INSTALLATION AND REMOVAL OF DECK ASSEMBLY



WARNING

Install this deck only on lawn tractors equipped with manual PTO deck engagement lever.



WARNING

Stop the tractor engine, place the PTO engagement lever in the "OFF" position, place all controls in neutral and engage the brake pedal lock before performing deck installation.



WARNING

When handling the mower deck, be careful not to cut yourself on the sharp blades.



CAUTION

The mower deck must be placed on a hard level surface during installation.

A. PREPARATION

Prior to beginning installation of the deck, refer to figure 1 and complete the following preparations:

1. Remove the hairpin cotter and the flat washer from the end of the deck hanger rod. Remove the deck hanger rod.
2. **Note the relative position of the right rear ferrule to the mounting bracket.** Remove the cotter pins and flat washers securing the ferrules. Remove the front and rear ferrules from the deck.
3. Set both gauge wheels to the lowest position. Refer to "GAUGE WHEEL ADJUSTMENT" on page 3-24.

B. INSTALLATION OF DECK

1. Lower the lift handle to its lowest setting.
2. Refer to figure 3. Note the relative position of the flat area at the top of the two rear lift links, to the welded lift pins of the lift carriage. Remove the hairpin cotters and flat washers which attach the rear lift links to the lift pins. Remove the two rear lift links.

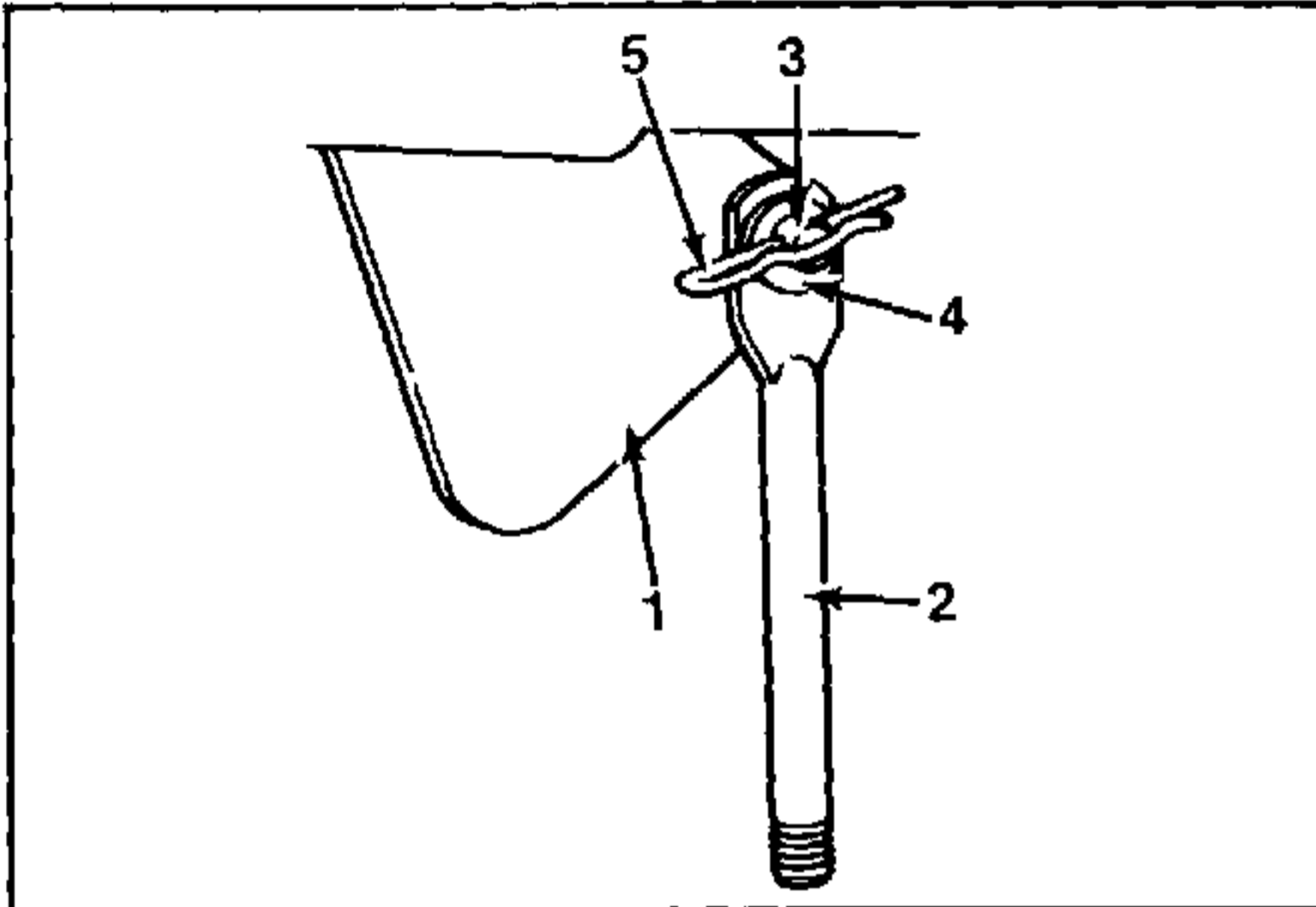

FIGURE 3.

- | | |
|-------------------|-------------------|
| 1. Lift Carriage | 4. Flat Washer |
| 2. Rear Lift Link | 5. Hairpin Cotter |
| 3. Lift Pin | |

3. Raise the lift handle to its highest setting. Refer to figure 4 and place the deck on the right side of the tractor, with the front of the deck facing toward the front of the tractor. Slide the deck under the tractor until it is aligned with the tractor as illustrated in figure 5.
4. Refer to figure 6. Lift the front end of the deck, and set the outside spindle nut on the face of a six inch long 2" x 4" wooden block (obtained from a wooden building stud). Repeat this step for the left spindle.
5. Lower the lift handle to position number 1. Screw a ferrule onto each of the rear lift links. Secure each of the rear lift links to the lift carriage lift pins using a flat washer and hairpin cotter.

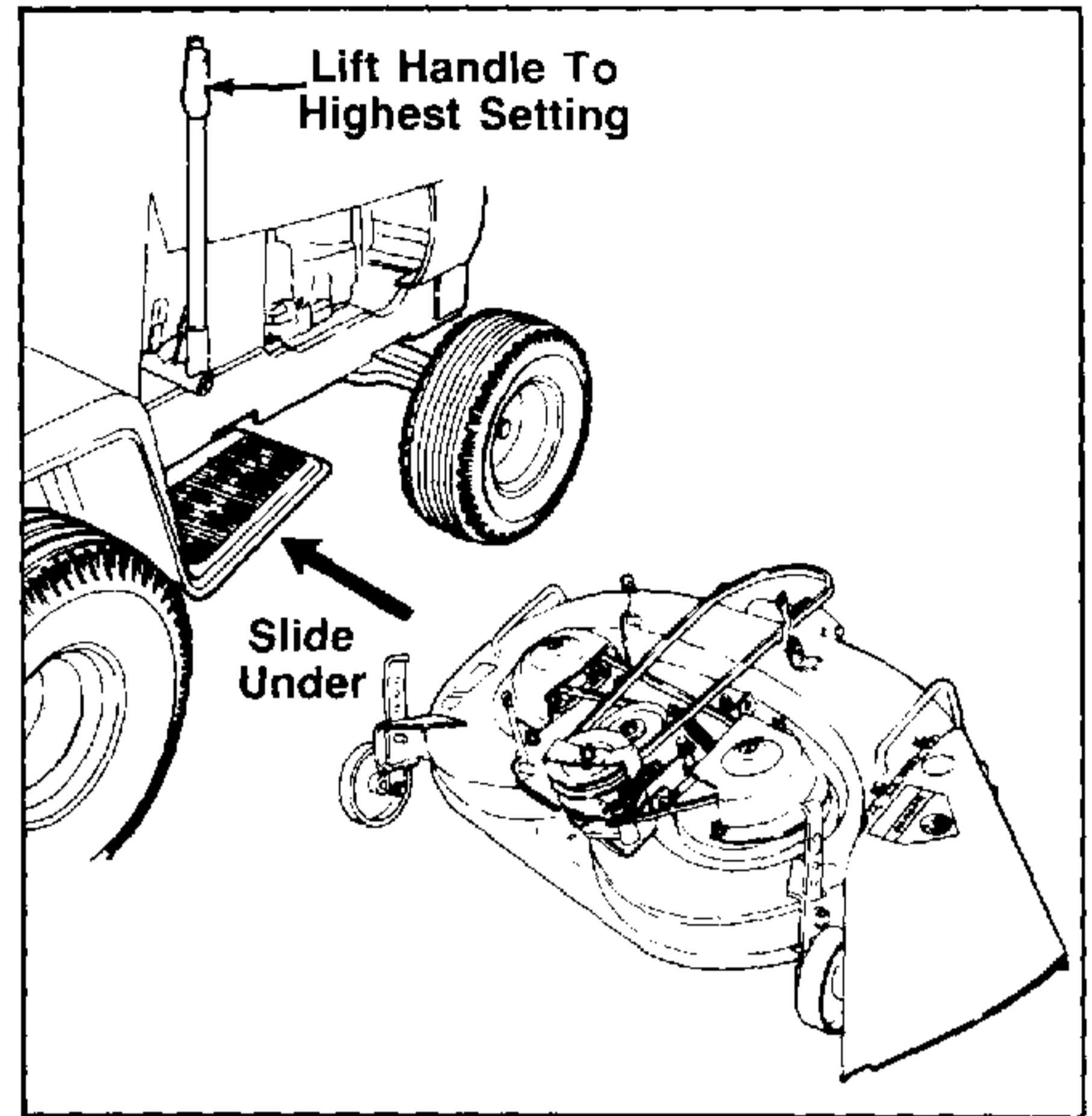

FIGURE 4.

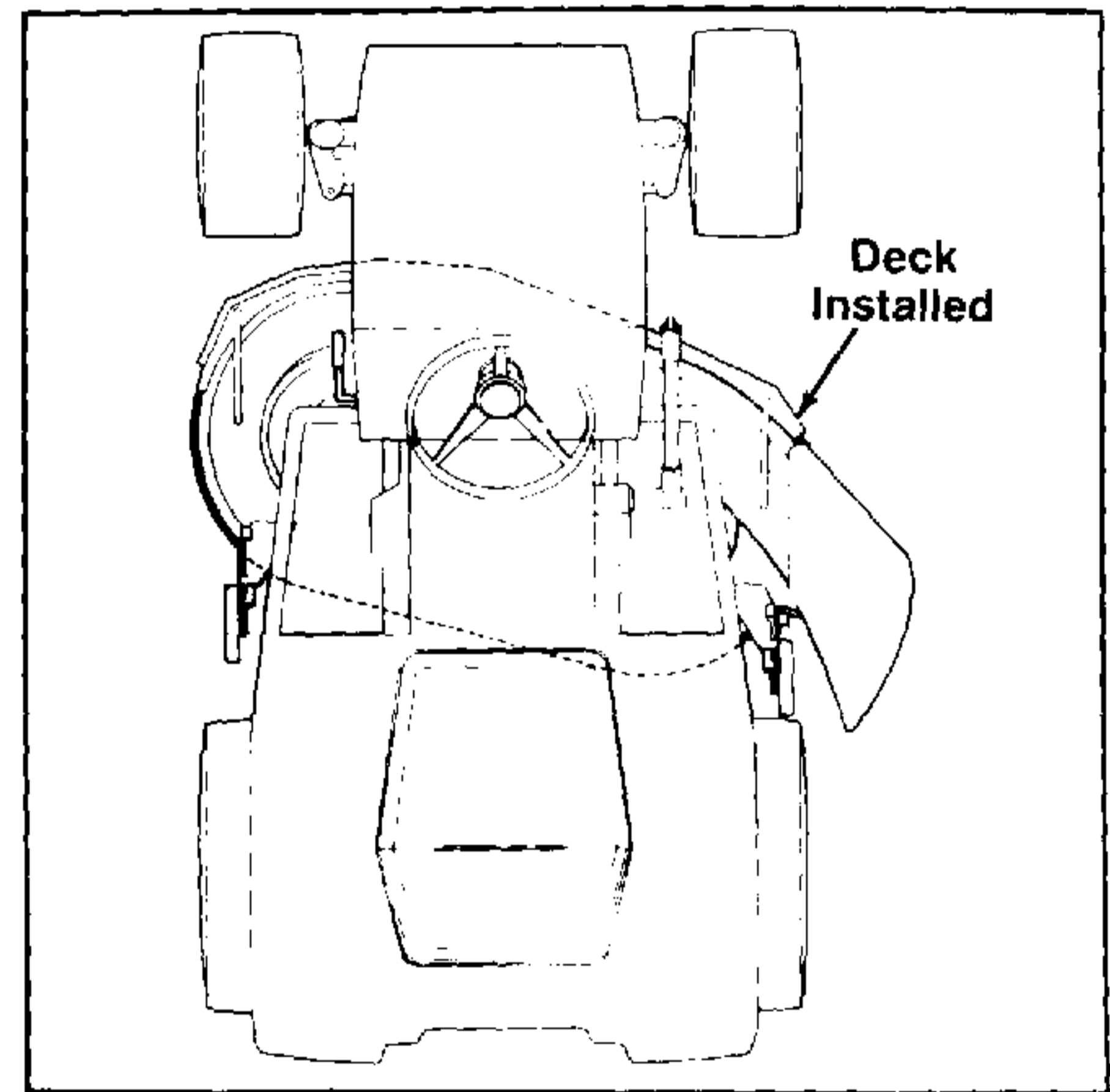

FIGURE 5.

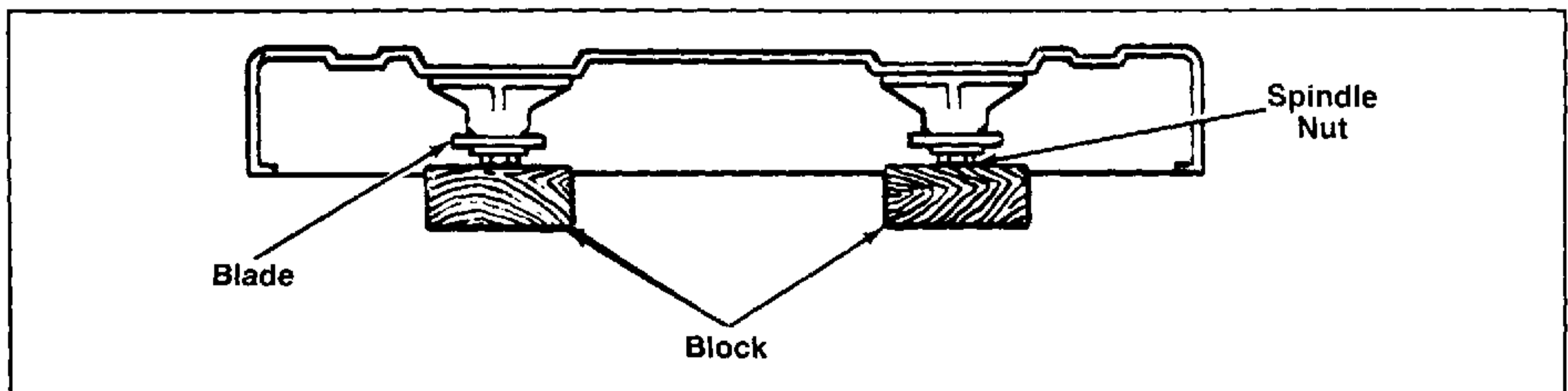

FIGURE 6.

- Adjust the ferrules on the rear lift links so that the small end of the ferrule lines up with the hole in the deck lift bracket. **When performing this step, recall the relative position of the right rear ferrule to the deck lift bracket.** Secure each of the rear ferrules to the deck lift brackets using a flat washer and a cotter pin.
- Screw on and position ferrules to the front lift links. Refer to figure 7 and secure the links to the front deck brackets with flat washers and cotter pins.

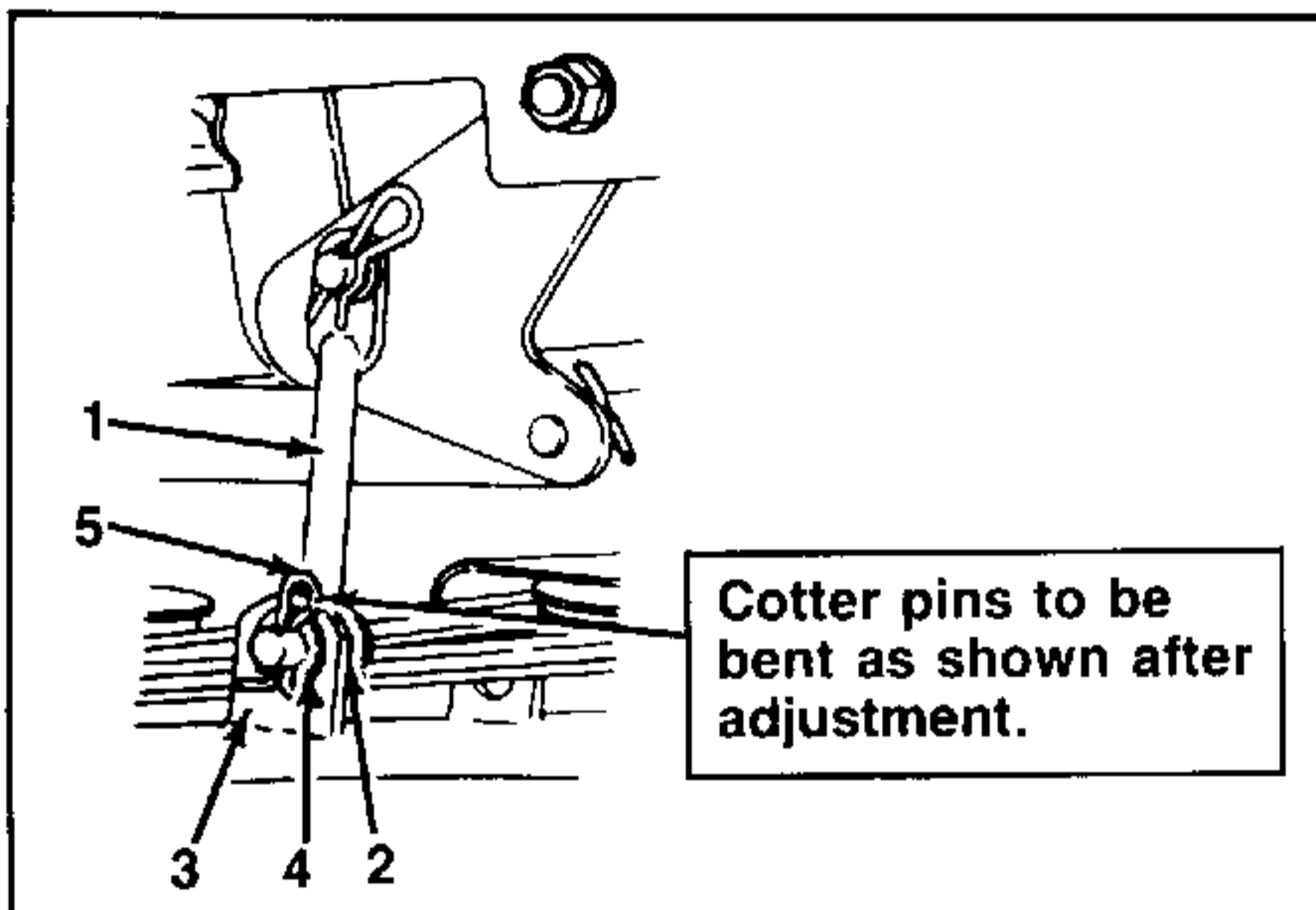

FIGURE 7.

- | | |
|----------------------------|----------------|
| 1. Front Lift Link | 4. Flat Washer |
| 2. Ferrule | 5. Cotter Pin |
| 3. Front Deck Lift Bracket | |

- Refer to figure 8 to determine the proper positioning of the front hanger assembly in relation to the tractor and deck. Note that when the front hanger assembly is properly positioned, the hanger extensions face the rear of the tractor, and the top hole of the front hanger assembly is open. Attach the rear of the front hanger assembly to the top of the

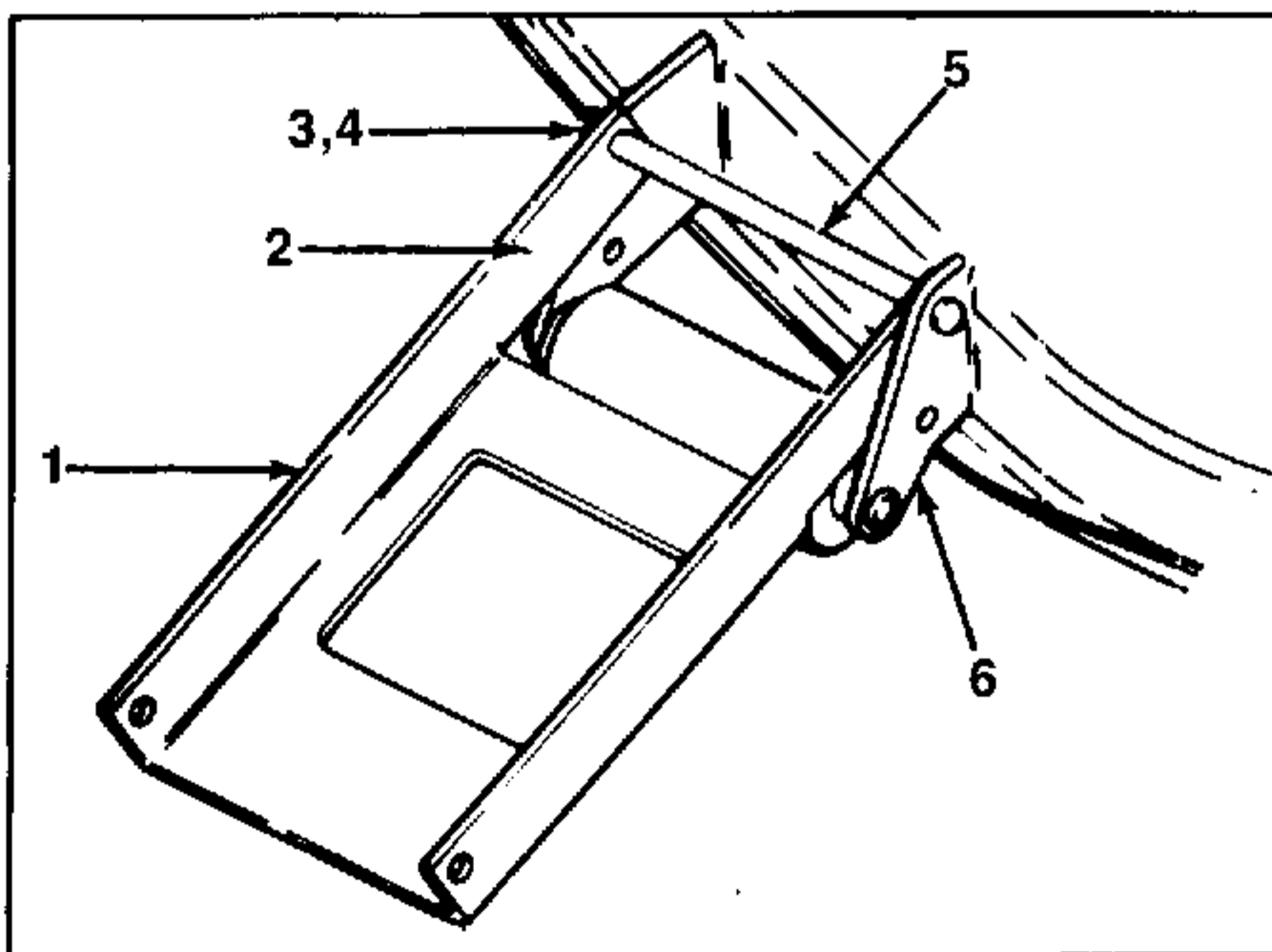

FIGURE 8.

- | | |
|--------------------------|-------------------------|
| 1. Front Hanger Assembly | 4. Flat Washer |
| 2. Hanger Extension | 5. Deck Hanger Rod |
| 3. Hairpin Cotter | 6. Front Roller Bracket |

front roller bracket using the deck hanger rod. Secure the rod to the bracket using a flat washer and hairpin cotter.

- With the left front wheel turned to the left, attach the front hanger assembly to the front hanger bracket by passing the tractor hanger rod through the bottom mounting holes of the front hanger bracket. Remember to attach the central flat washer to the rod after it passes through the right side of the front hanger assembly. Refer to figure 9. Secure the tractor hanger rod with flat washer and hairpin cotteners.

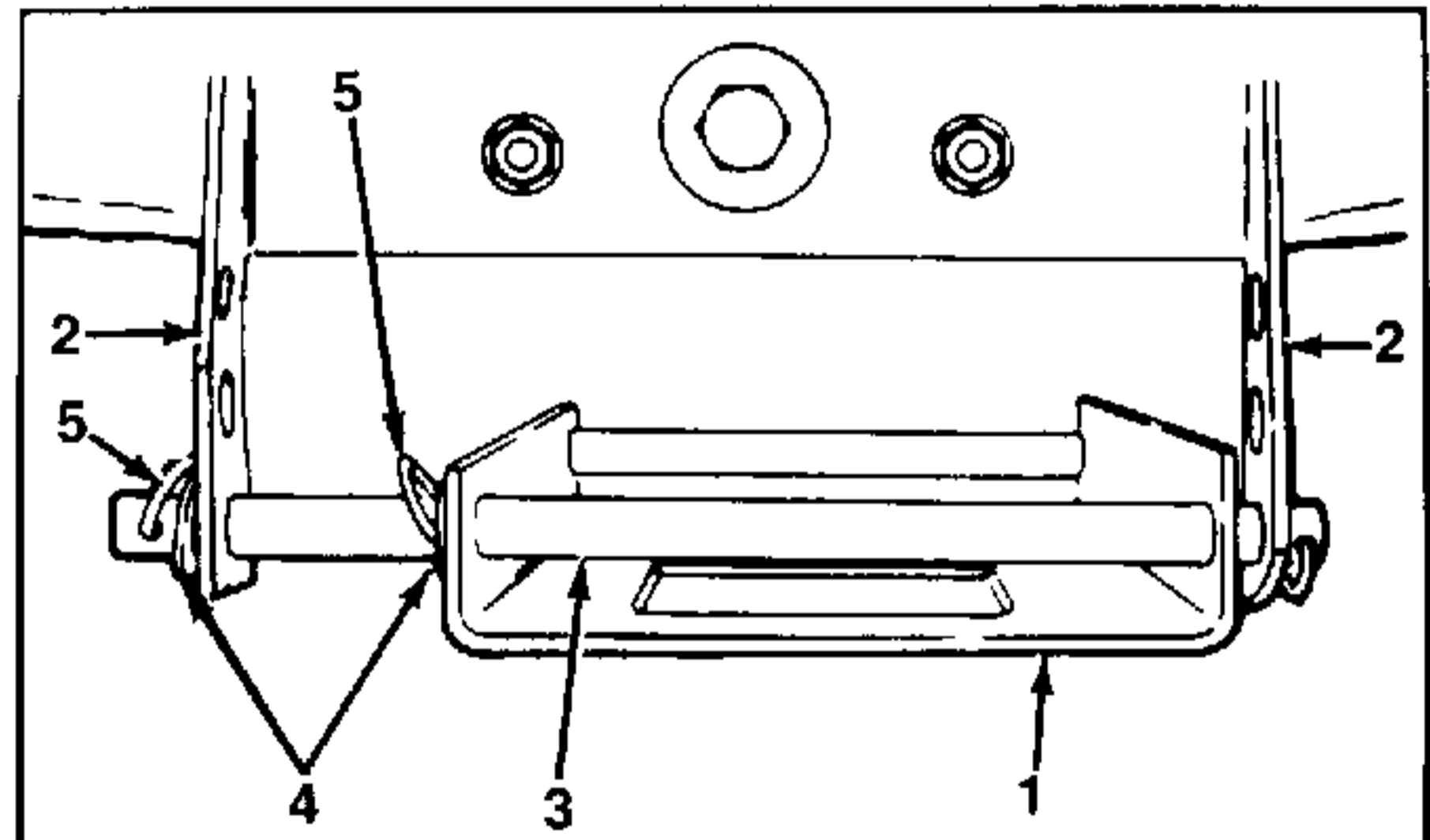

FIGURE 9.

- | | |
|--------------------------|-------------------|
| 1. Front Hanger Assembly | 4. Flat Washer |
| 2. Front Hanger Bracket | 5. Hairpin Cotter |
| 3. Tractor Hanger Rod | |

- With the PTO engagement lever in the "OFF" position, install the PTO drive belt while working from the left side of the tractor. Push the engine drive pulley belt guard upward and toward the front of the tractor to allow the belt to be installed on the engine drive pulley. Refer to figure 10.

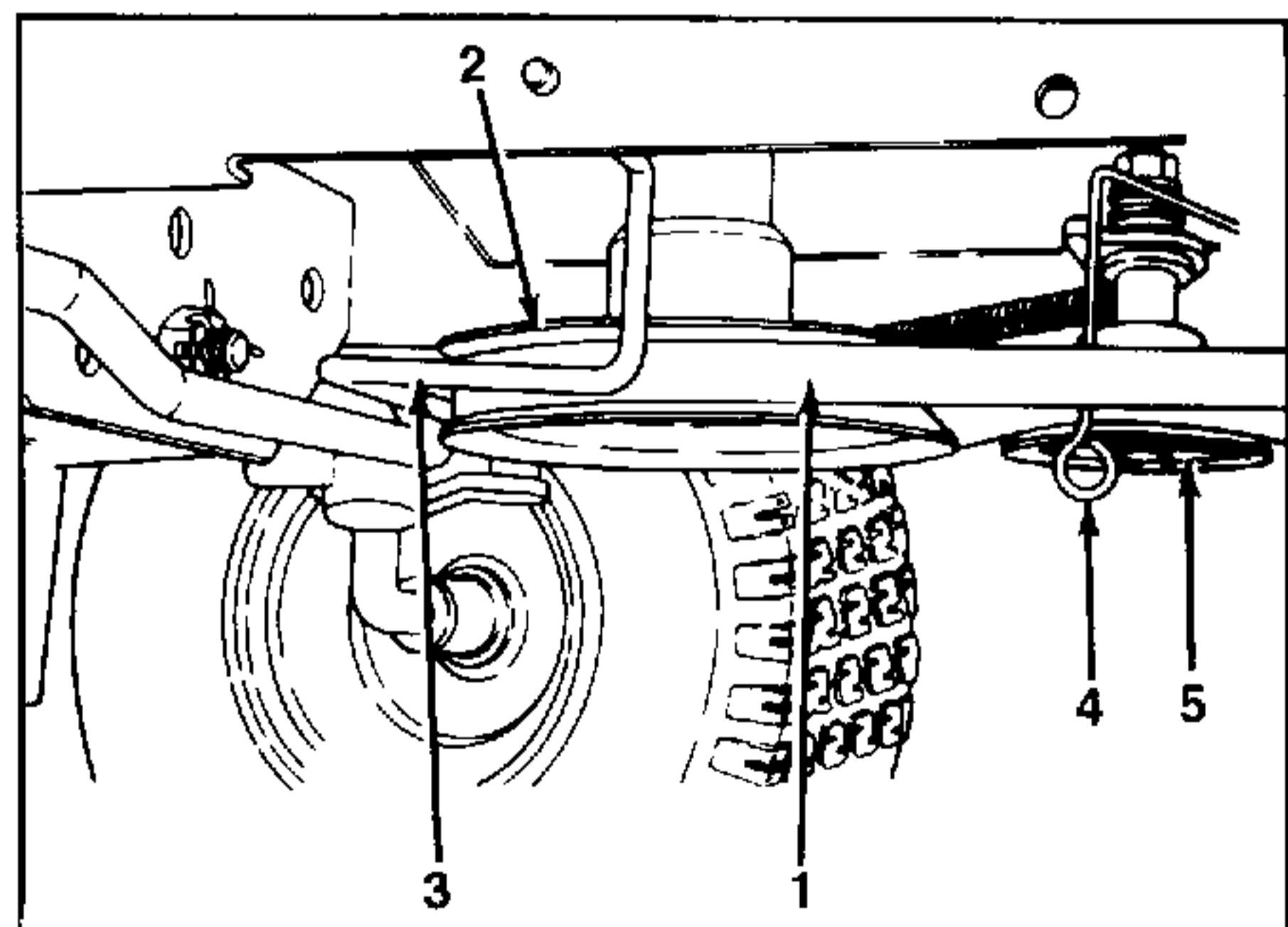

FIGURE 10.

- | |
|-----------------------------------|
| 1. PTO Drive Belt |
| 2. Engine Drive Pulley |
| 3. Engine Drive Pulley Belt Guard |
| 4. Idler Pulley Belt Guard |
| 5. Idler Pulley |

 **NOTE**

The deck brake rod must be positioned outside and to the left of the PTO drive belt when installing the PTO drive belt.

11. To install the PTO drive belt to the idler pulley, pull the loop on the idler pulley belt guard away from the idler pulley. Slide the belt onto the idler pulley and release the idler pulley belt guard. Refer to figure 10.

C. DOUBLE DRIVE PULLEY BELT GUARD ADJUSTMENT



CAUTION

Following "INSTALLATION OF DECK," adjustment to the double drive pulley belt guard **MUST** be made. Failure to make this adjustment could result in damage to PTO drive belt.

Refer to "DOUBLE DRIVE PULLEY BELT GUARD ADJUSTMENT" located on page 3-24 for instructions regarding this important adjustment.

D. REMOVAL OF DECK ASSEMBLY

Removal of the mower deck from the tractor is essentially the reverse of the steps presented in "INSTALLATION OF DECK" located on page 3-20.



WARNING

Stop the tractor engine, place the PTO engagement lever in the "OFF" position, place all controls in neutral and engage the brake pedal lock before performing deck removal.



WARNING

When handling the mower deck, be careful not to cut yourself on the sharp blades.



CAUTION

The tractor must be placed on a hard, level surface during deck removal.

SECTION IV. ADJUSTMENTS

A. DECK LEVELING ADJUSTMENTS

In order to achieve even cutting, the mower deck must be properly leveled. This leveling procedure will result in the left and right blades having corresponding front cutting-edge-to-ground measurements within 1/16 inch. Also, the right and the left blades will each have a 1/16 to 1/8 inch downward tilt toward the front of the tractor. Proceed as follows:



WARNING

Before making any adjustments, turn off the machine, remove the key, and engage the brake pedal lock to avoid accidental starting and injury.



WARNING

When adjusting the mower deck, be careful not to cut yourself on the sharp blades.



CAUTION

If the mower deck is not level, the mower will not cut your lawn evenly.

 **NOTE**

Check the tires for proper inflation before making a level adjustment. To level the deck, the tractor **MUST** be placed on a hard, level surface.

1. The gauge wheels should be set to the lowest position as described in "GAUGE WHEEL ADJUSTMENT" located on page 3-24.
2. Place the lift handle (figure 11) in position number 6.
3. Disconnect the spark plug wire(s).

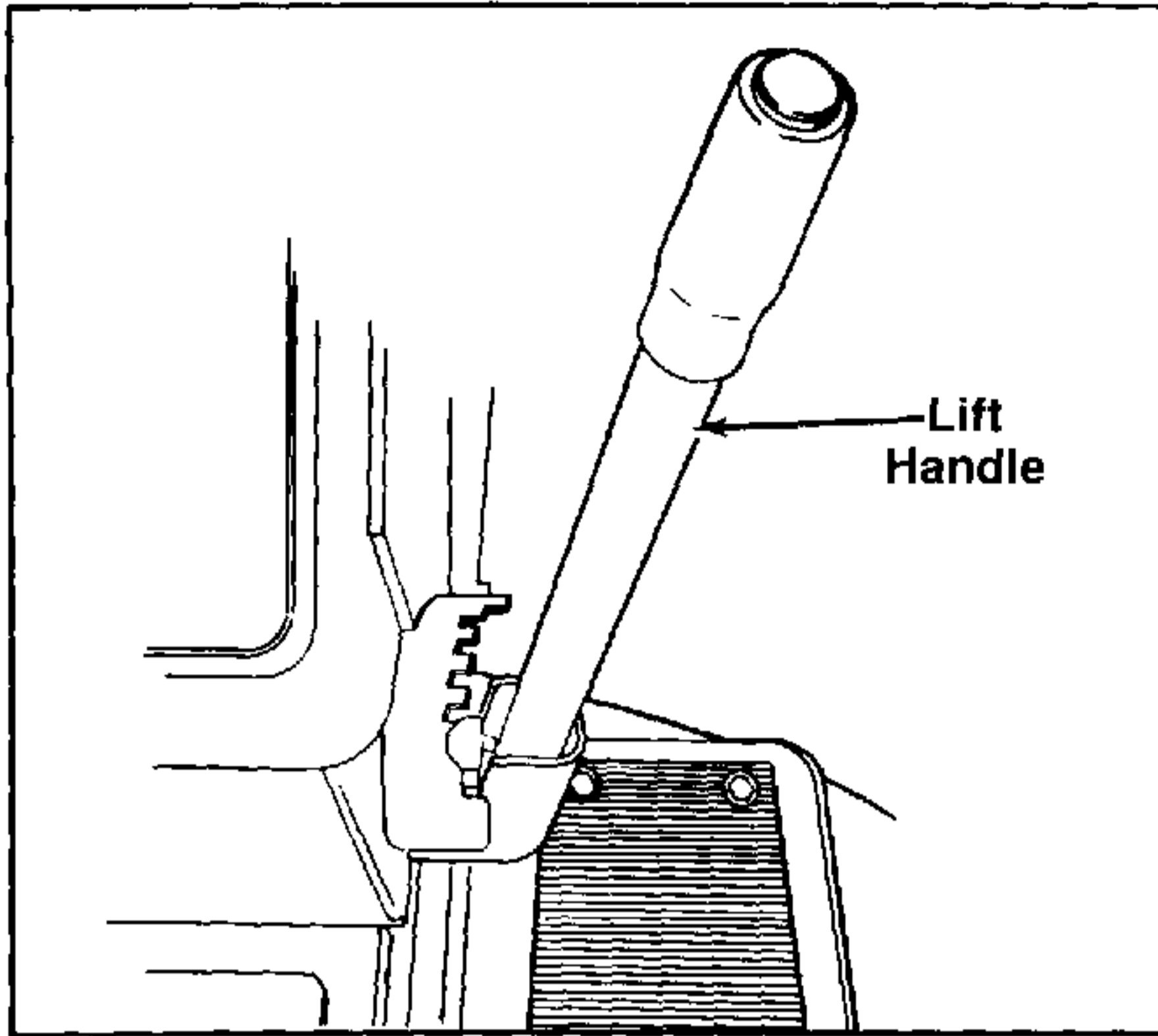

FIGURE 11.

4. Position the mower blades so that the ends of each blade face the front and rear of the tractor. Refer to figure 12.
5. Refer to figure 13. Measure and record the distance from the hard, level surface to the CUTTING EDGE at the front and rear of each of the blades. Hereafter, these measurements will be referred to as the cutting-edge-to-ground distances.
6. Determine which blade has the highest front cutting-edge-to-ground distance. Adjustments designed to place the front cutting-edge-to-ground measurements of the two blades within 1/16 inch of one another are performed on the blade which has the highest recorded front cutting edge-to-ground measurement.
7. Begin by placing the lift handle in position number 1. Refer to figure 11. Remove the hairpin cotter and flat washer which secure the front lift link to the lift carriage lift pin. Remove the front lift link from the lift carriage lift pin.
8. Turn the lift link counterclockwise (out of the ferrule), until the front cutting-edge-to-ground distance on the high blade is equal to the corresponding blade measurement on the opposite side of the deck. Each 360 degree turn of the lift link equals approximately 1/16 inch.
9. Reposition the front lift link onto the lift carriage lift pin, and secure with a flat washer and hairpin cotter.
10. Place the lift handle in position number 6, and remeasure the front cutting-edge-to-ground distance on the high blade. If it is within 1/16 inch of the corresponding measurement on the opposite blade, proceed to step 11. If the two measurements

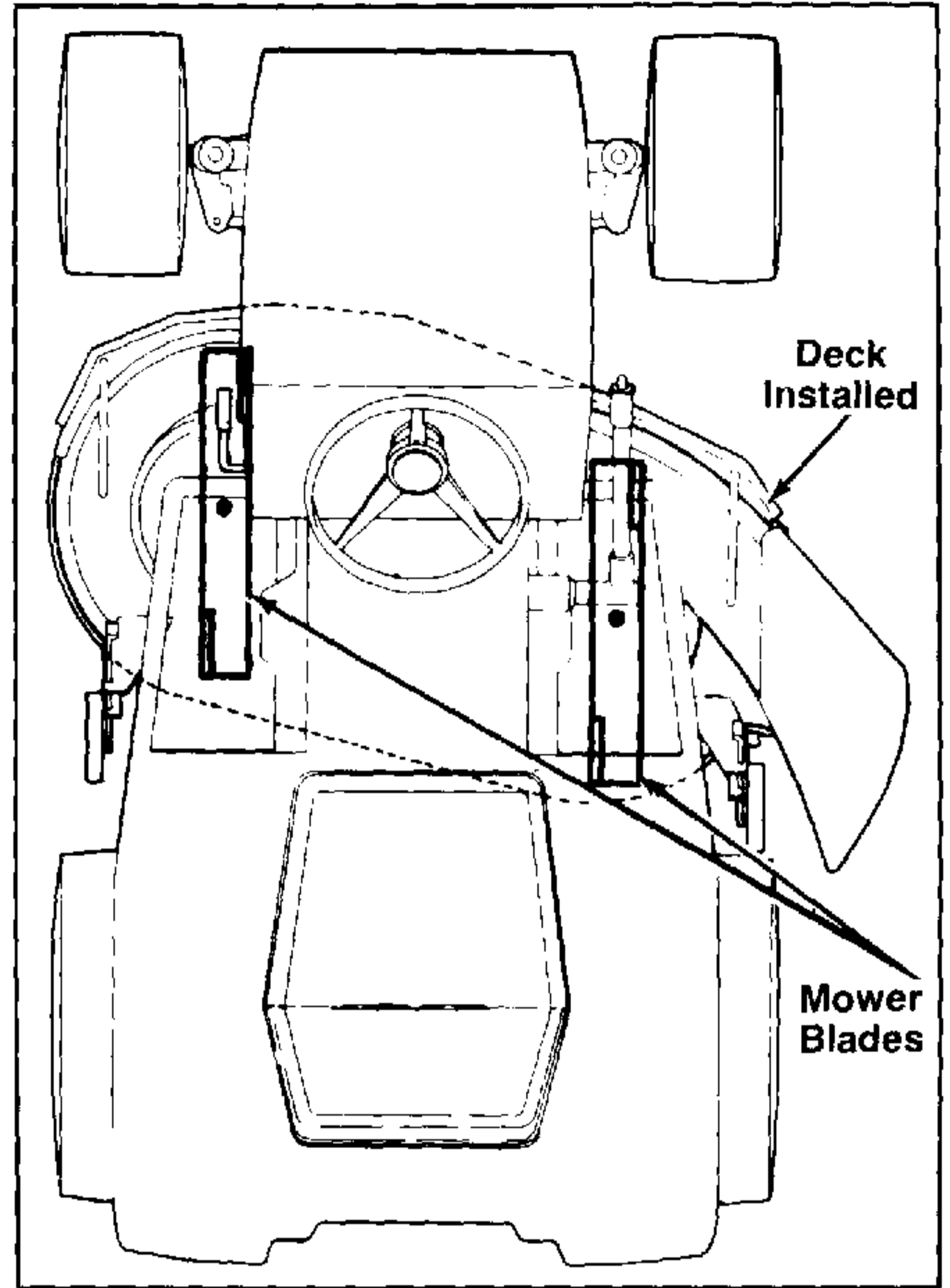

FIGURE 12.

- are not within 1/16 inch, repeat steps 6, 7, 8, 9, and 10 until the desired measurement is achieved.
11. With the lift handle in position number 6, repeat and record the blade measurements described in step 5. Refer to your recorded cutting-edge-to-ground measurements. Each of the two blades must have a downward tilt toward the front of the tractor. A proper tilt is achieved when a blade's rear cutting-edge-to-ground measurement (measurement A+, figure 13) is 1/16 to 1/8 inch higher than that blade's front cutting-edge-to-ground measurement (measurement A, figure 13). If a proper tilt does not exist for one or both of the blades, refer to step 12.
12. Place the lift handle in position number 1. Working on side of the deck corresponding to the blade being adjusted, refer to figure 5 and remove the hairpin cotter and flat washer securing the rear lift link to the lift carriage lift pin. Remove lift link from the lift pin.
13. Rotate the lift link into or out of the ferrule to achieve the 1/16 to 1/8 inch downward tilt of the blade. Each 360 degree rotation of the lift link equals approximately 1/16 inch. Clockwise rotation of the lift link increases the tilt; counterclockwise rotation decreases the tilt.

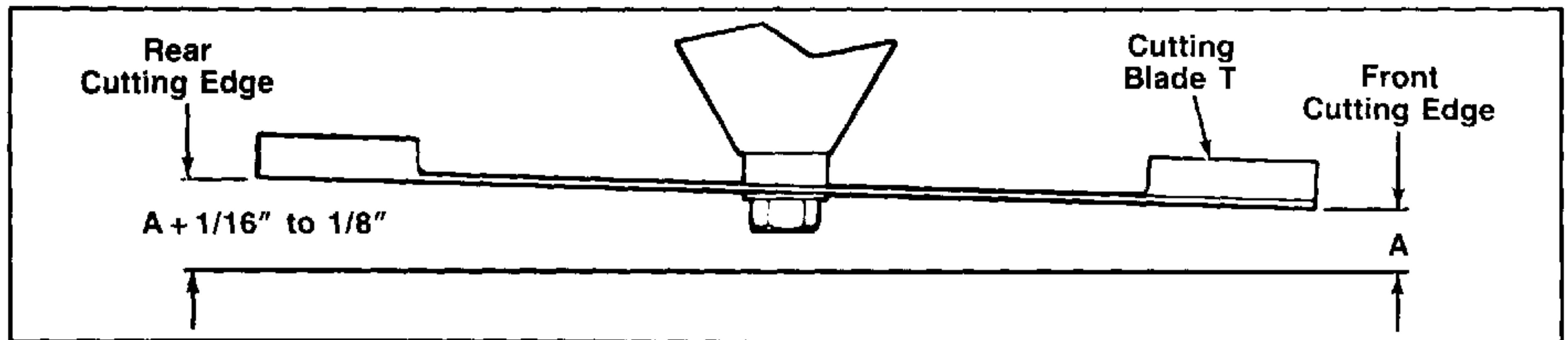

FIGURE 13.

14. Reposition the rear left link onto the lift carriage lift pin. Secure with a flat washer and hairpin cotter.
15. Place the lift handle in the highest setting. Remeasure the front and the rear cutting-edge-to-ground distances to confirm that the proper blade tilt, as described in step 11, has been achieved. If the proper tilt has not been achieved, repeat steps 11, 12, 13 and 14.

B. GAUGE WHEELS



Gauge wheel adjustment should be done only **AFTER** the deck has been properly installed.

In order to adjust the height of the gauge wheels, proceed as follows:

1. Pull out the quick release pin.
2. With pin pulled out, slide the gauge wheel bracket up or down until desired height is reached.
3. Reinsert the quick release pin.



There are half height adjustment holes along with the adjustment holes in the gauge wheel bracket. Both gauge wheels must be set in the same relative hole locations. Refer to figure 14.

C. DOUBLE DRIVE PULLEY BELT GUARD ADJUSTMENT

1. Remove the frame cover by removing two screws holding the frame cover to the frame in the step through area. Refer to figure 15.
2. Remove the ball knob from end of dump valve (Model 1320). Refer to figure 15.
3. Lift up and slide frame cover rearward from underneath the pedestal.

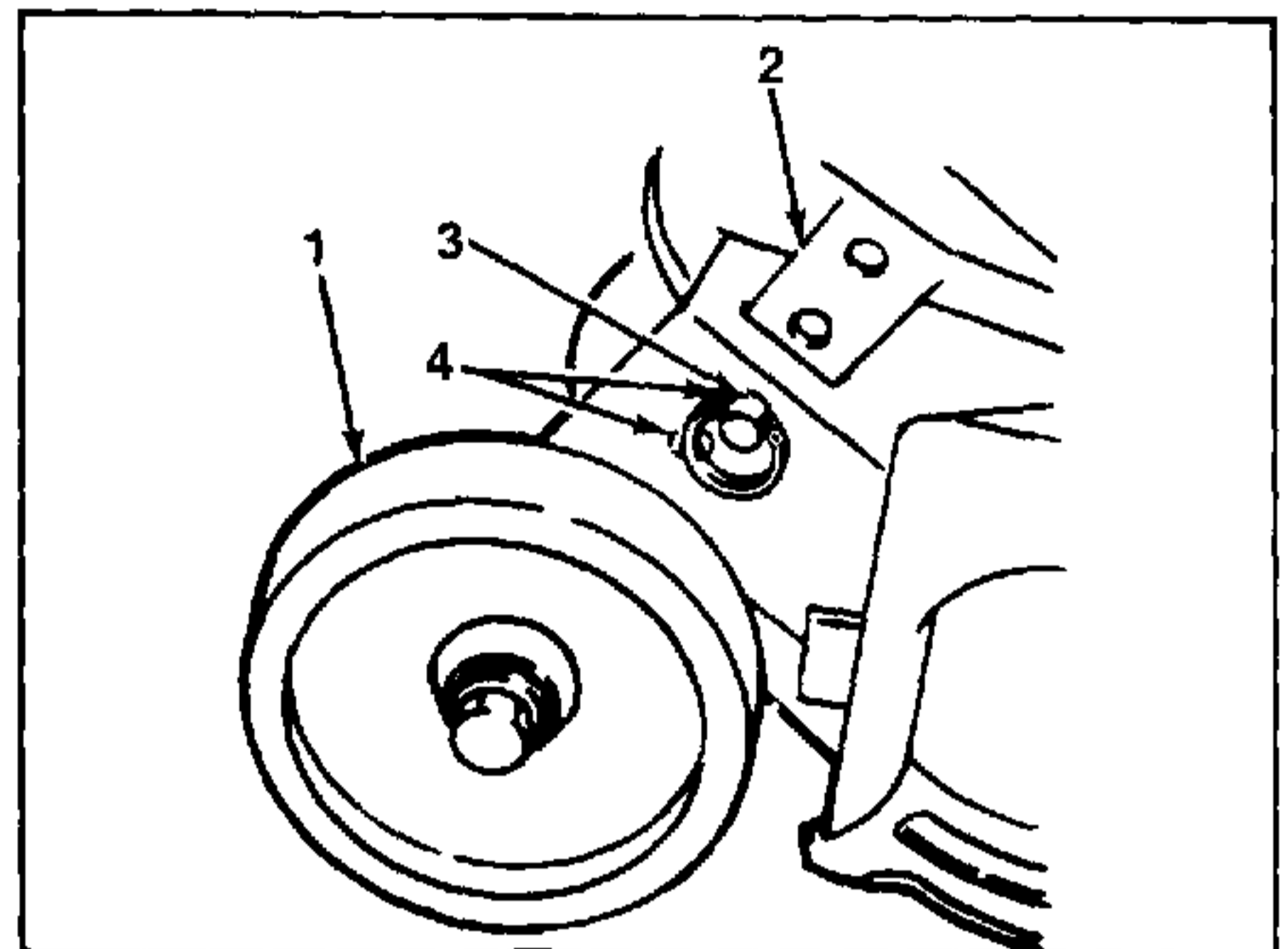

FIGURE 14.

1. Gauge Wheel
2. Gauge Wheel Bracket
3. Quick Release Pin
4. Half Height Adjustment Holes

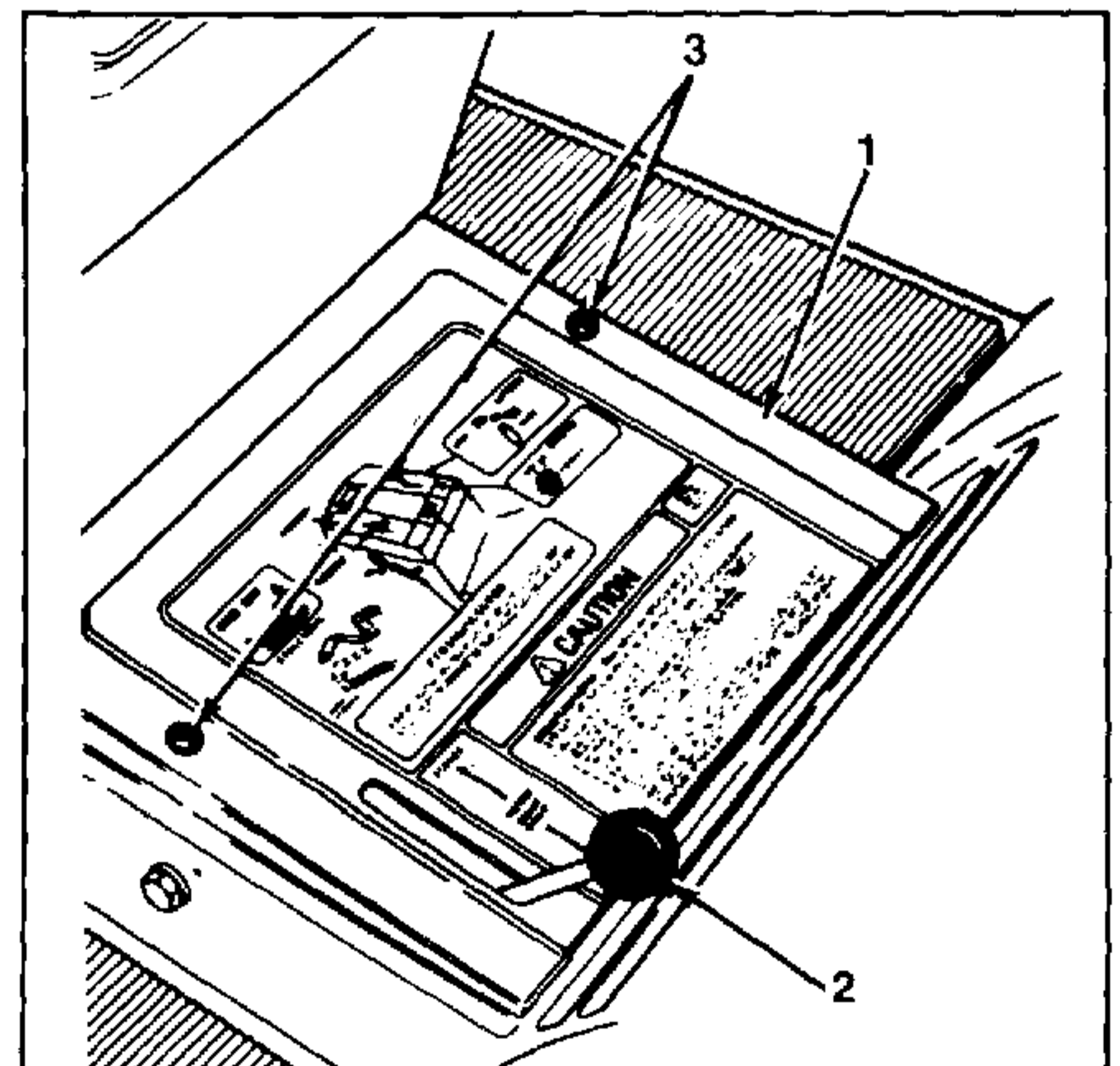

FIGURE 15.

1. Frame Cover
2. Ball Knob
3. Screw

4. Place the PTO engagement lever in the "ON" position. Refer to figure 16.
5. Place the tractor lift handle in position 3 or 4 as shown on the lift height indicator.

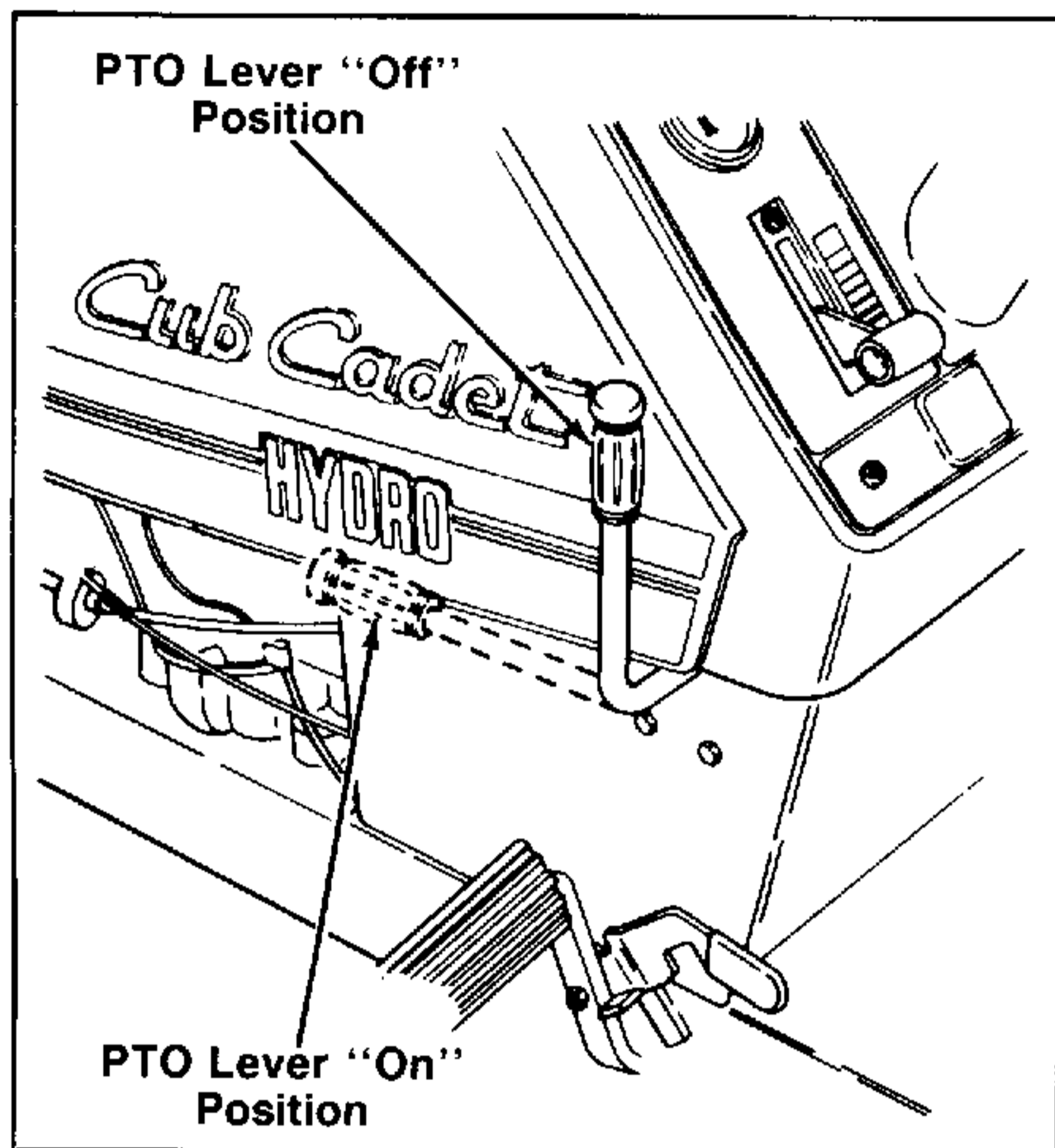

FIGURE 16.

6. While sitting on the tractor seat, look through the frame and locate the deck double drive pulley and belt guard. The double drive pulley belt guard should be positioned so that the PTO drive belt is the same distance (approximately 1/4 inch) from each edge of the belt guard. Refer to figure 17.

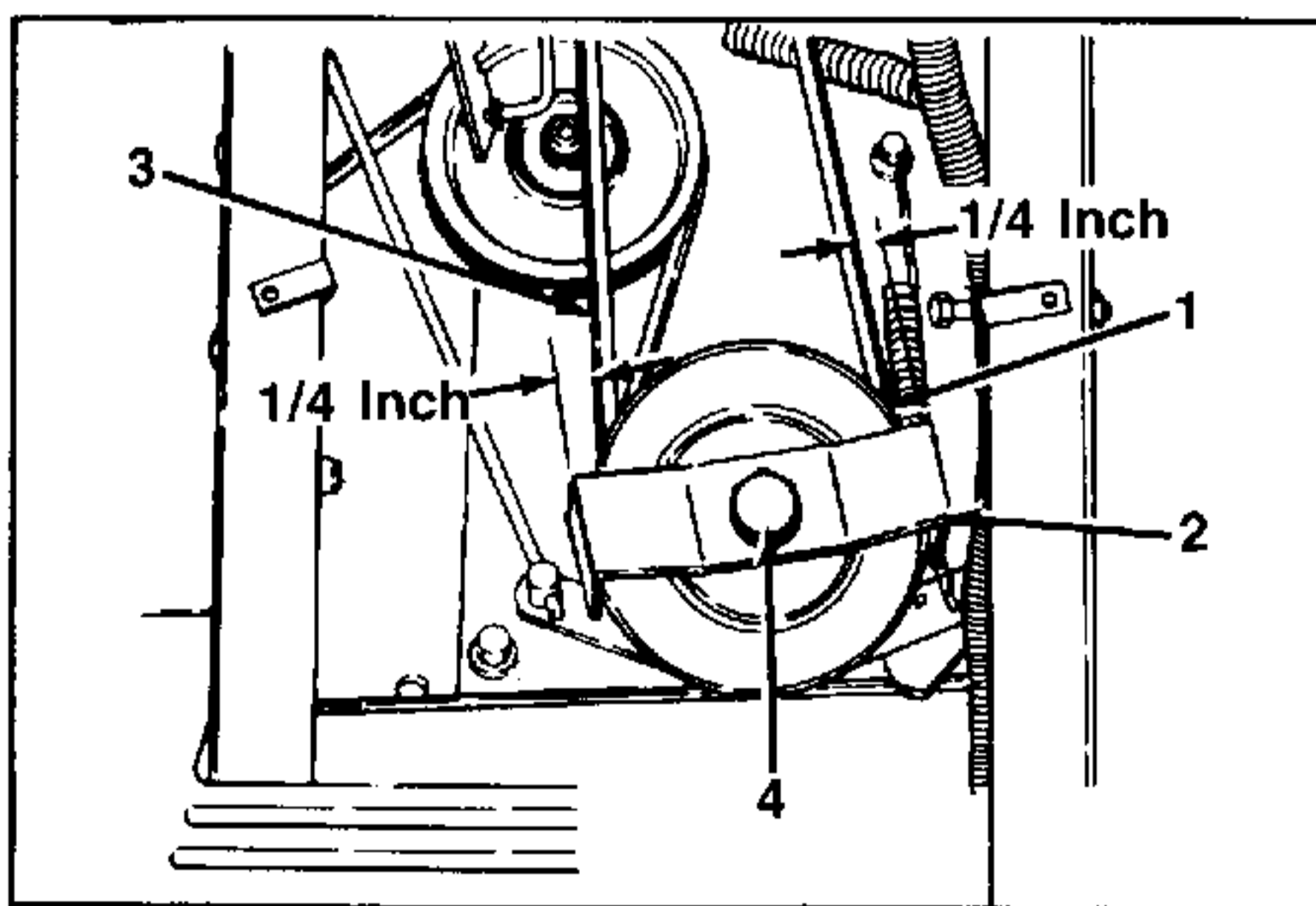

FIGURE 17.

1. Double Drive Pulley
2. Double Drive Pulley Belt Guard
3. PTO Drive Belt
4. Bolt

7. If adjustment is required, the bolt holding the belt guard and double drive pulley to the deck can be moved. Retighten the bolt and recheck the belt guard position as in step 6.

NOTE

Do not completely loosen the bolt since the double drive pulley is under spring tension.

8. Reassemble the frame cover using the two screws and reinstall the ball knob to the dump valve handle if necessary.

D. DECK BRAKE ROD ADJUSTMENT

1. Place the PTO engagement lever in the "OFF" position. Refer to figure 16.
2. Place the tractor lift handle in position 3 or 4 as shown on the lift height indicator.
3. While working from the left side of the tractor, locate the clutch rod and retaining spring on the manual clutch bracket, under the tractor. Refer to figure 18.

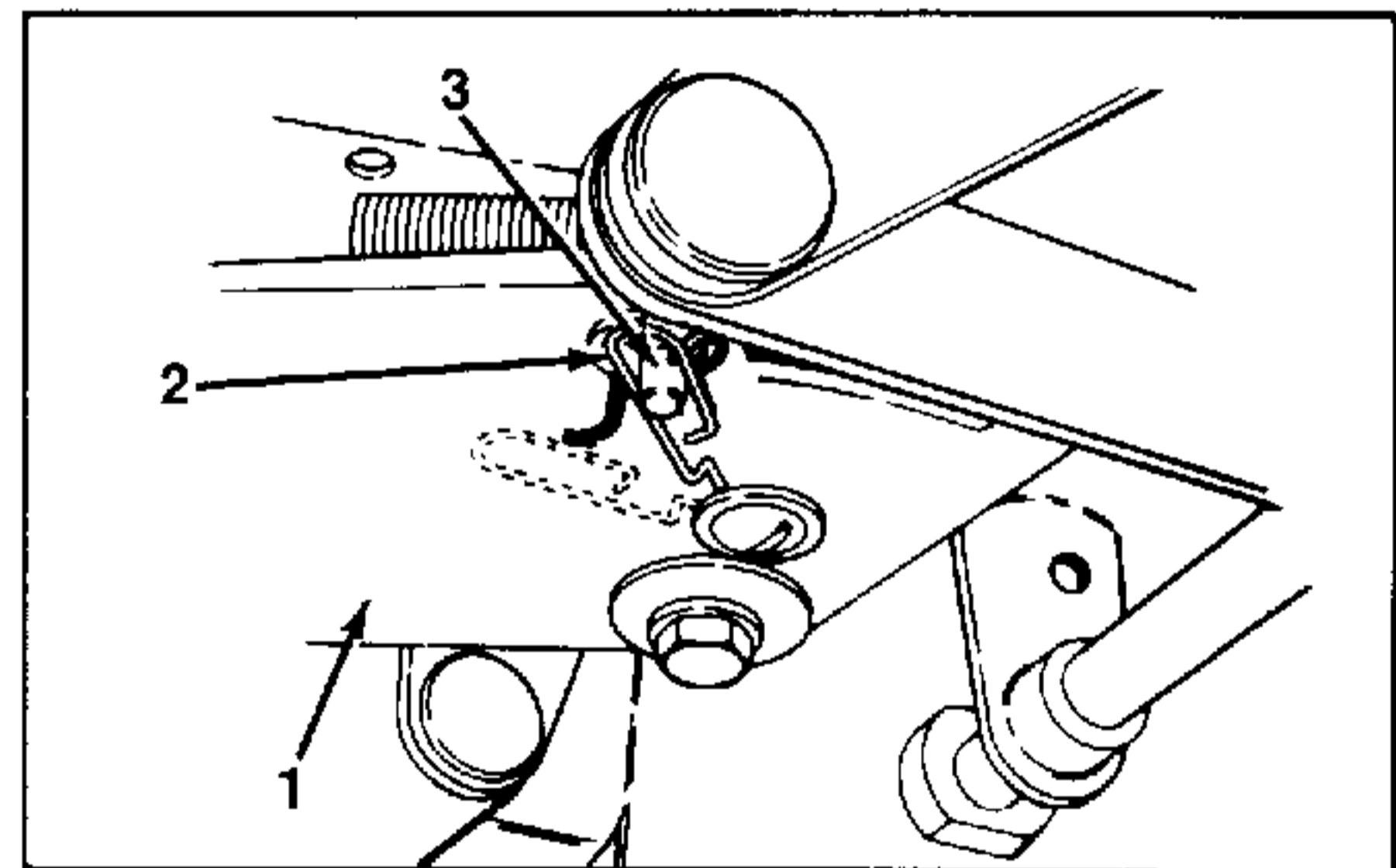

FIGURE 18.

1. Manual Clutch Bracket
2. Retaining Spring
3. Clutch Rod
4. Pull the retaining spring off the clutch rod by pulling down and across towards the right side of the tractor. Refer to figure 18.

NOTE

Do not distort the retaining spring.

5. To attach the brake rod to the clutch rod, turn the brake rod in (shorten) or out (lengthen) of the ferrule mounted to the brake bracket assembly. Refer to figure 19.

- With the ferrule to the back of the slot in the brake bracket assembly, adjust the brake rod so that it can be slid onto the clutch rod. Shorten the brake rod 3 complete turns to allow for proper clearance in the slot.

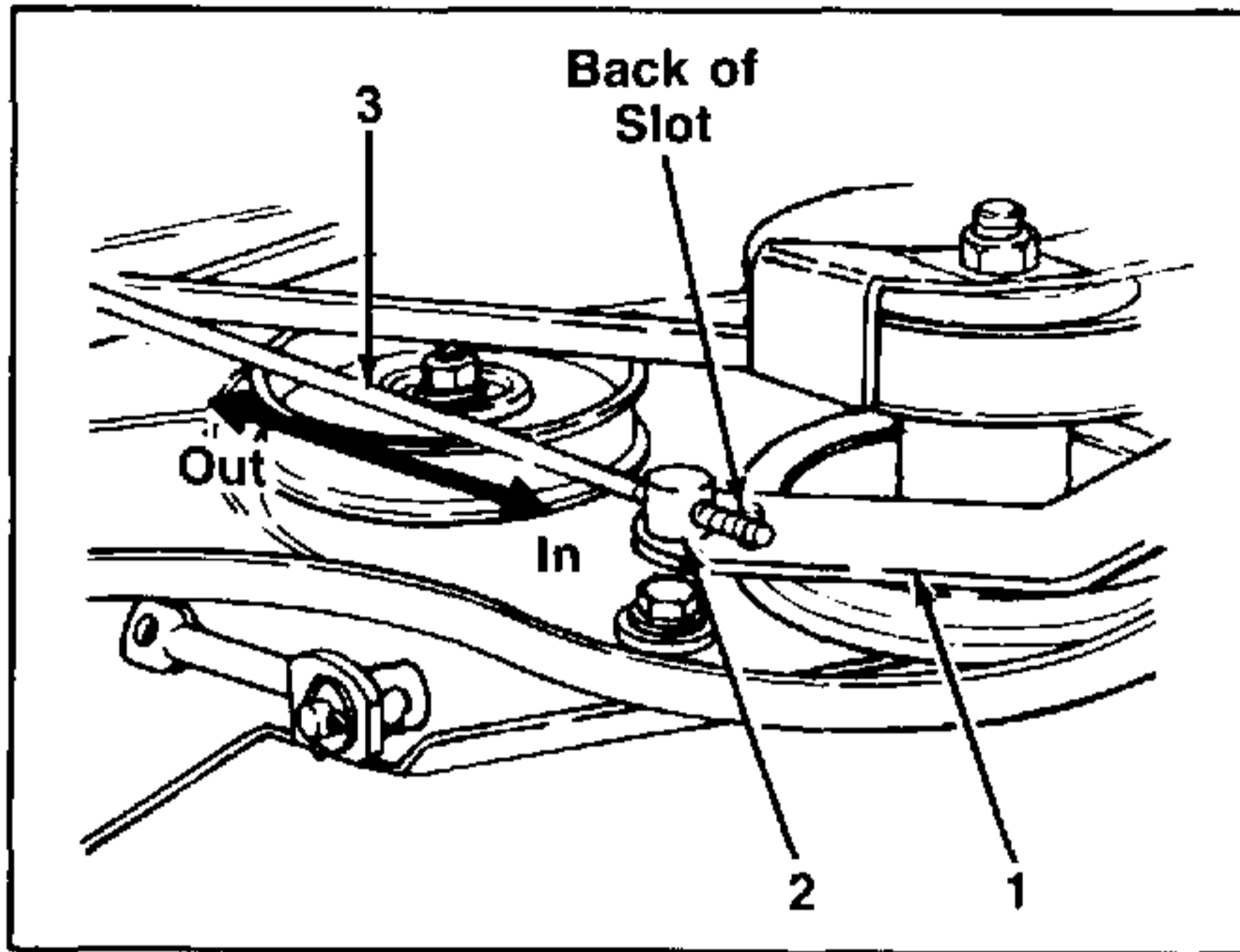

FIGURE 19.

- Brake Bracket Assembly
- Ferrule
- Brake Rod

- Attach the brake rod to the clutch rod; reposition the retaining spring over the clutch rod capturing the brake rod. Refer to figure 20.

➡ NOTE

The brake rod must be positioned to the outside left of the PTO drive belt.

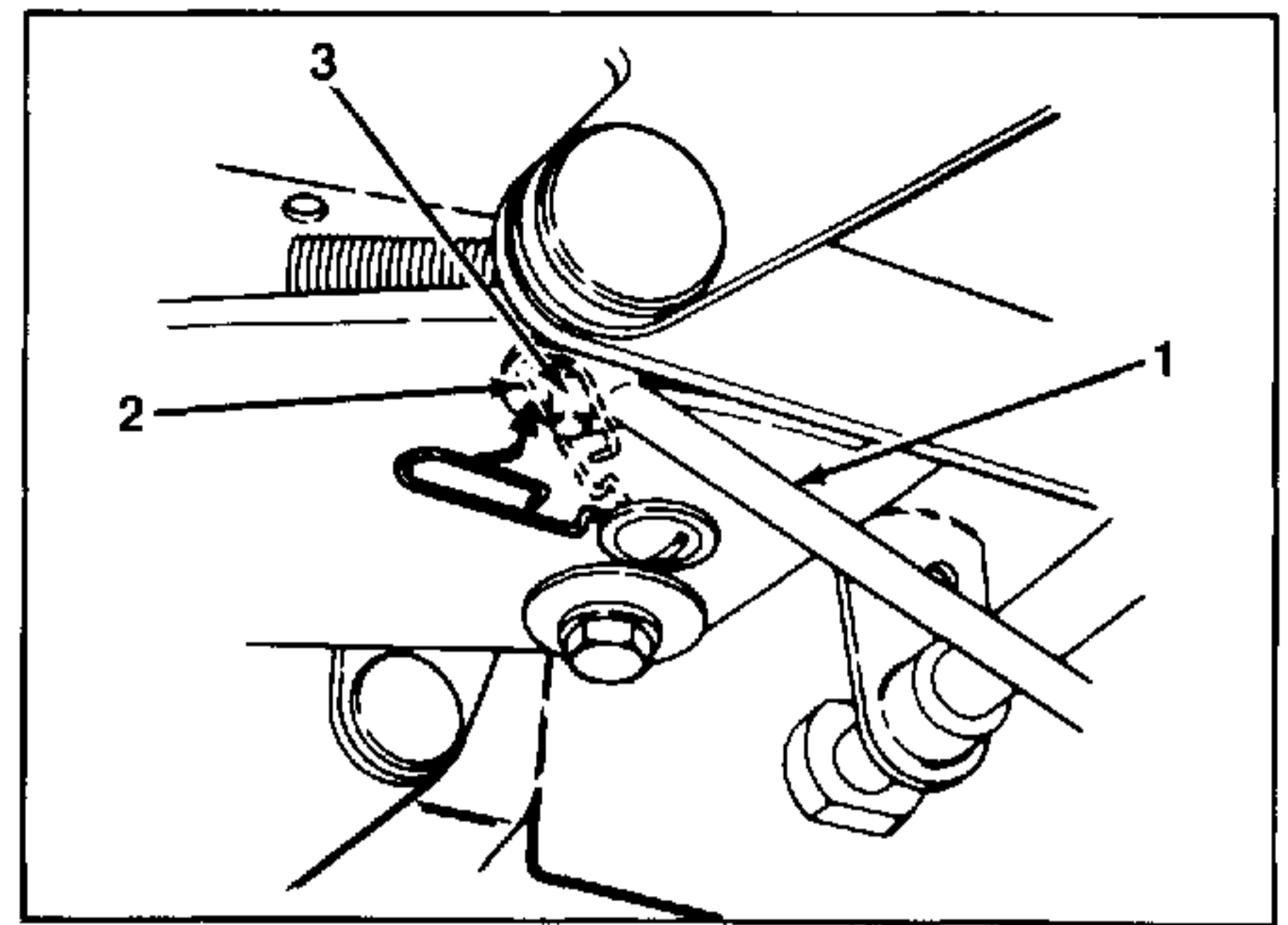

FIGURE 20.

- Brake Rod
- Retaining Spring
- Clutch Rod

E. CUTTING HEIGHT

The mower can be set in multiple positions. Proceed as follows:

- Pull the lift handle back slightly and depress the button on the top of the lift handle.
- Release the button when the desired mower position is obtained.

➡ NOTE

To return the mower to a specific position, note position of the lift lever indicator in relation to the lever position decal before raising or lowering the mower.

SECTION V. MAINTENANCE

A. CLEANING AND BLADE CARE



WARNING

Stop the tractor, place the PTO engagement lever in the off position, place all controls in neutral, engage the parking brake lock and stop the engine before performing any maintenance.



WARNING

Be careful not to cut yourself when sharpening the blades or cleaning the underside of the mower.

Clean the underside of the mower deck at the end of the mowing season and when buildup of cut material on the underside is noticed. Also remove the belt covers and remove any accumulation.

The cutting blades must be kept sharp at all times.

➡ NOTE

Sharpen ends evenly so that the blades remain balanced and the same angle of sharpness is maintained. However, if the cutting edge of a blade has been sharpened to within 3/8 inch of the wind wing, it is recommended that new blades be installed. New blades are available at your authorized dealer.

When removing the blades, hold the hex shaped pulley hub with a 1¼ inch socket wrench to remove the hex nut holding the blade. A block of wood may be placed between housing and cutting edge of blade to assist in removal of hex nut securing blade. Refer to figure 21.

After replacing blades, grease the threaded end of the shaft to prevent rust buildup.

When replacing the blades, be sure they are assembled so the cutting edges are in the direction of rotation with the wind wings pointed upward. Tighten the nuts 50 to 60 ft-lbs. (68 to 81 N•m).

NOTE

If the spindle pulley nuts are removed for any reason, they should be retightened to 90 to 110 ft-lbs. (122 to 149 N.m) torque when replaced.

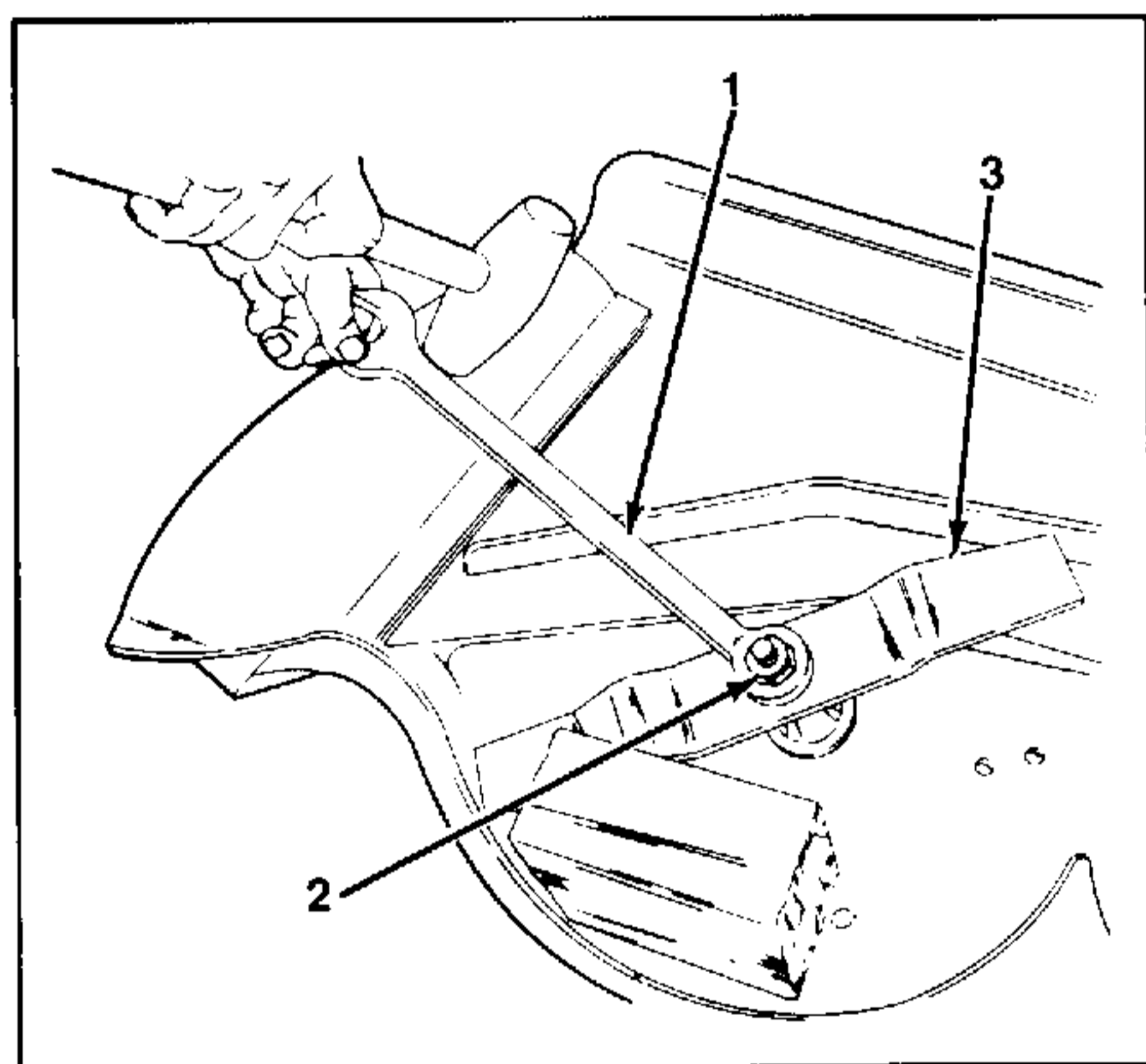

FIGURE 21.

1. 1-1/8 Inch Wrench
2. Hex Nut
3. Blade

B. LUBRICATION

After every 50 hours of operation and/or before putting into winter storage, lubricate the spindle assemblies using 251H EP grease or equivalent No. 2 multipurpose lithium grease. The grease will be expelled from the top spindle seal. Since the spindle pulley covers the top spindle seal, the expelled grease cannot be seen. When the spindle is fully greased, the expelled grease will cause the top spindle seal to give off a muffled crackling noise. Refer to figure 22.

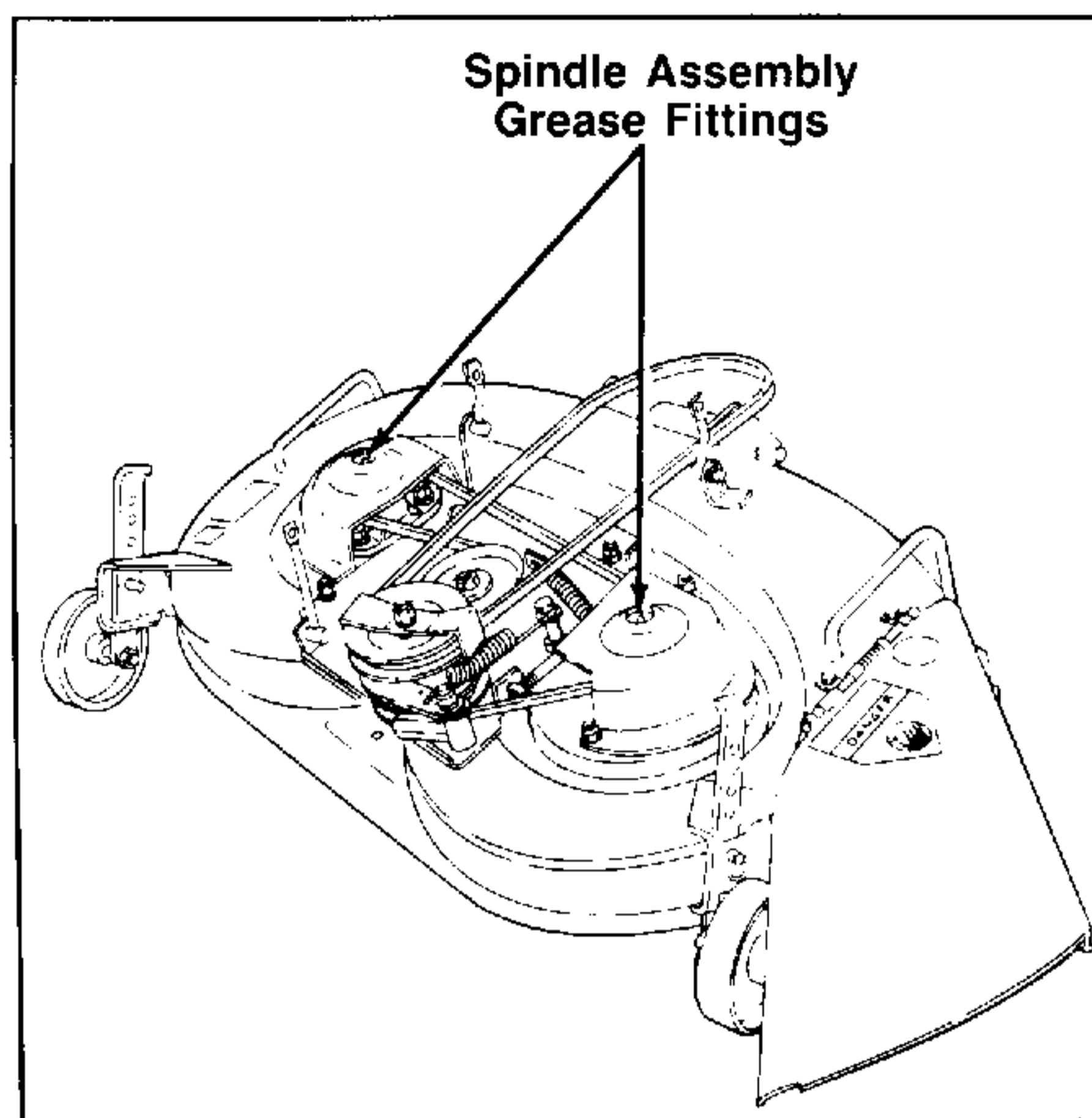

FIGURE 22.

C. BELT REPLACEMENT

Before replacing the spindle drive belt or the front PTO drive belt, the mower deck must be removed from the tractor. Refer to "REMOVAL OF DECK ASSEMBLY" on page 3-32. Remove mower deck and proceed as follows:

SPINDLE DRIVE BELT REPLACEMENT

1. Remove the nuts and washers that secure the spindle belt covers to the deck. Remove the spindle belt covers.
2. Refer to figure 23. Move the flat idler pulley to the left in order to relieve tension on the belt, and remove the spindle drive belt from the flat idler pulley.

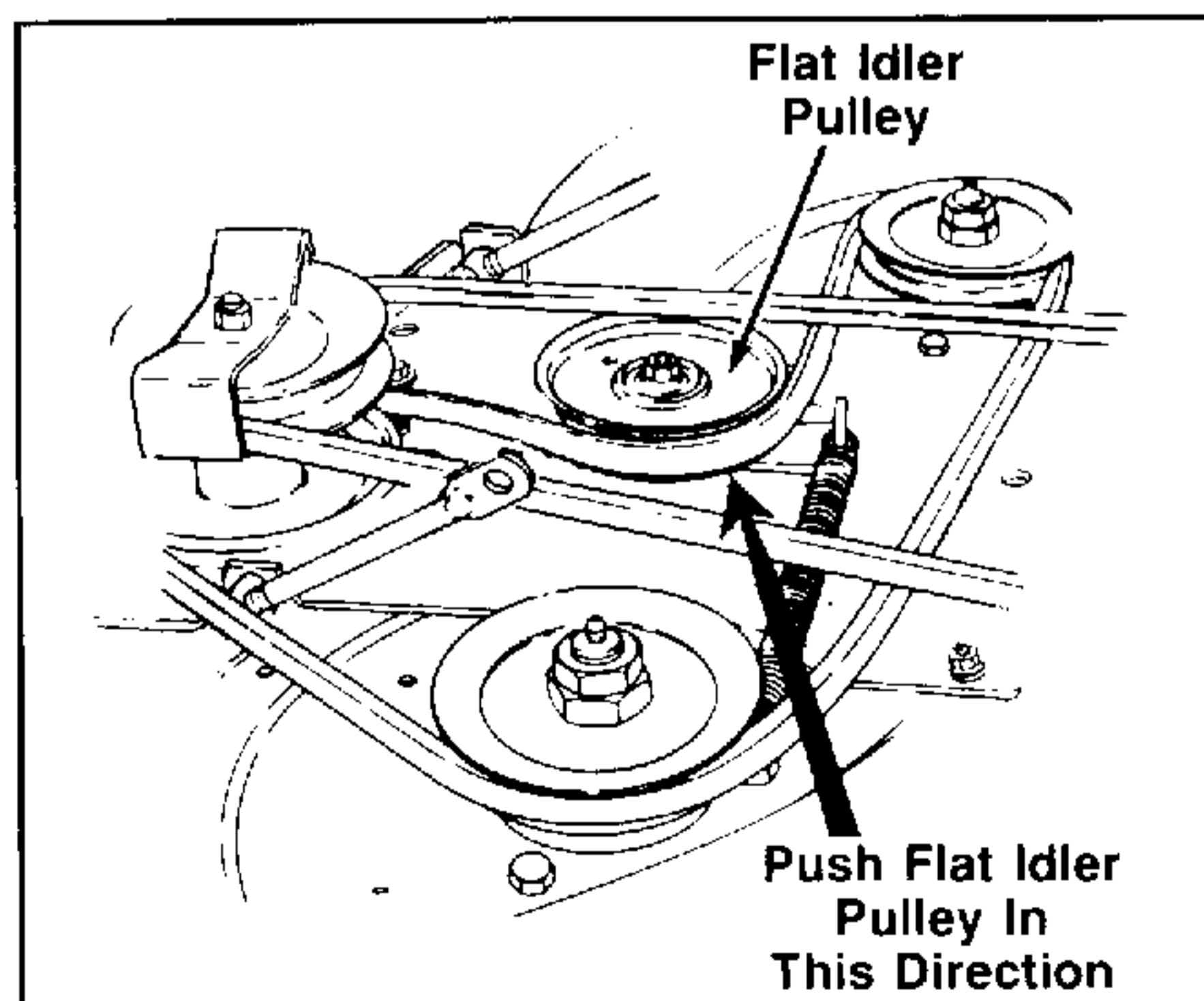

FIGURE 23.

3. Refer to figure 24. Release the deck brake spring from its attachment to the brake bracket. Swing the brake bracket assembly toward the right side of the deck to allow the belt to be removed.

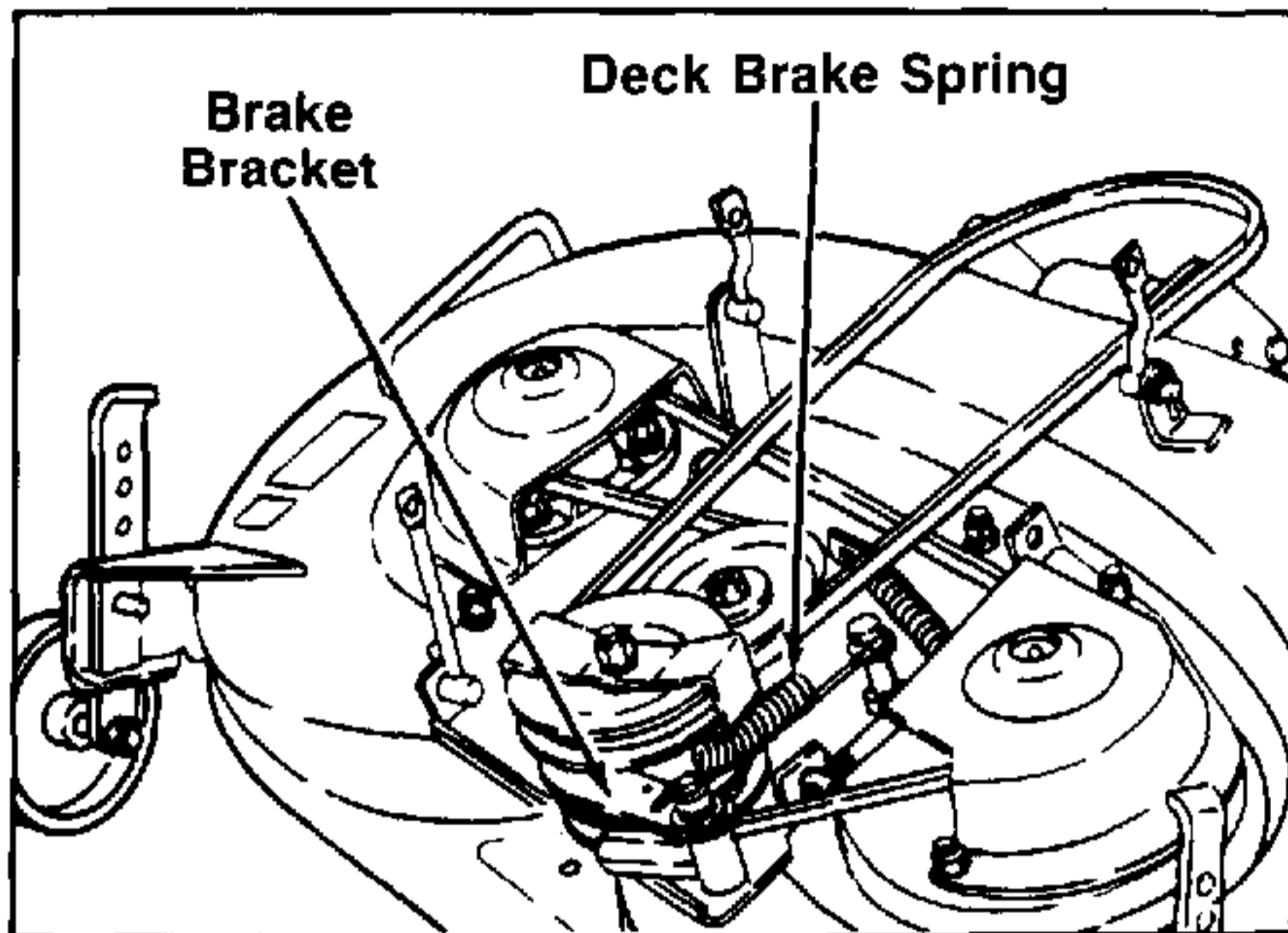

FIGURE 24.

4. Refer to figure 25 and remove the spindle drive belt from the double drive pulley and from the spindles.
5. Remove the spindle drive belt and replace with a new belt. Installation of the spindle drive belt is essentially the reverse of the removal process described in steps 1 through 4.

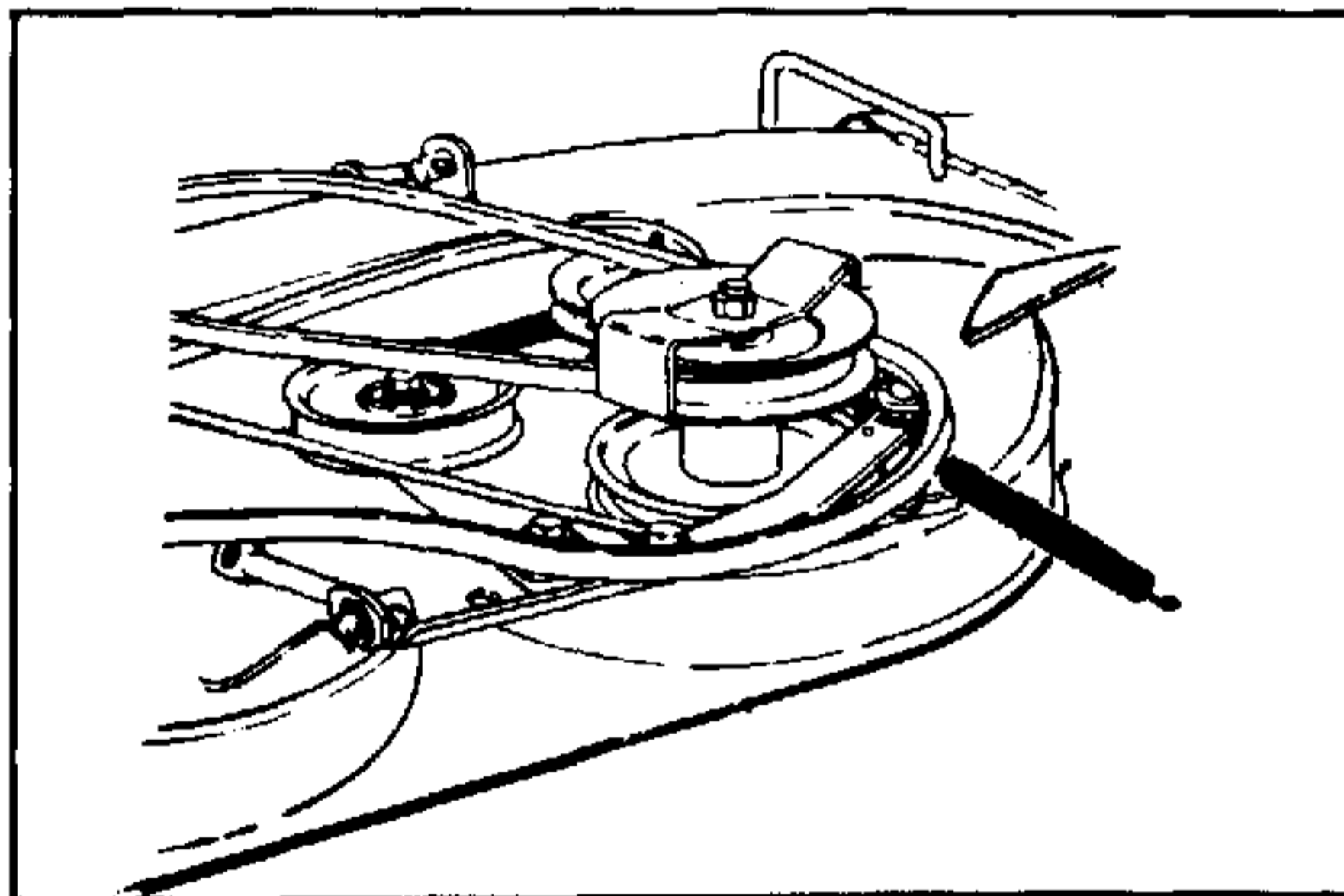

FIGURE 25.

FRONT PTO DRIVE BELT REPLACEMENT

1. Refer to figure 26 and carefully note the relative position of the double drive pulley belt guard to the double drive pulley.
2. Remove the hex nut and washer which secure the double drive pulley belt guard. Remove the belt guard.

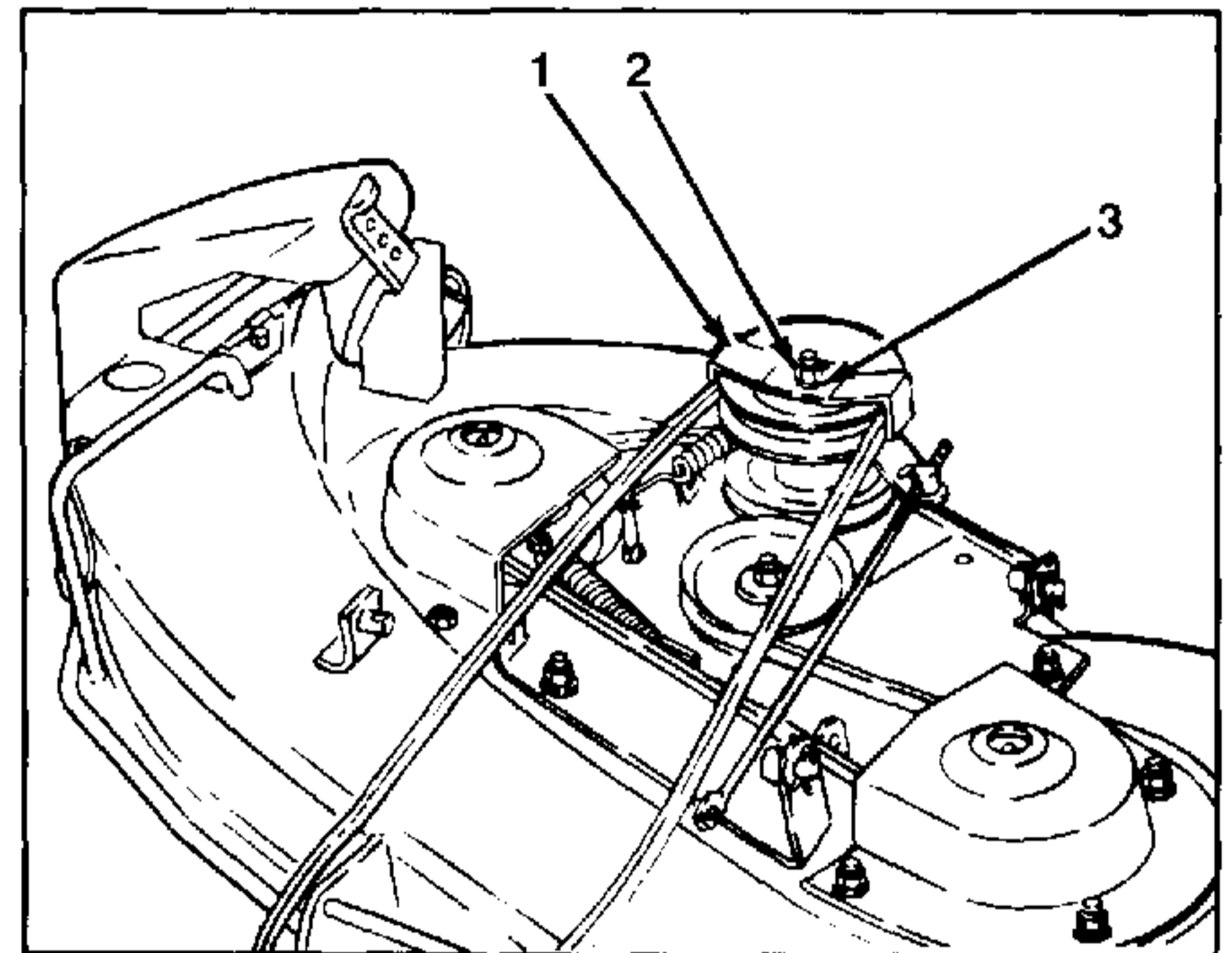

FIGURE 26.

1. Double Drive Pulley Belt Guard
 2. Hex Nut
 3. Washer
3. Remove the front PTO drive belt from the double drive pulley, and replace with a new belt.
 4. Install the double drive pulley belt guard in the same position noted in step 1. Secure the belt guard in proper position using the washer and hex nut.

When the PTO drive belt has been replaced, the mower deck reinstalled onto the tractor, and the front PTO drive belt positioned onto the engine drive pulley and the idler pulley, refer to "DOUBLE DRIVE PULLEY BELT GUARD ADJUSTMENT" on page 12 to check for proper adjustment.

LUBRICATION GUIDE

The life of any machine depends upon the care it is given. Proper lubrication is a very important part of that care.

Be certain that all lubrication fittings are assembled in place, using the lubrication illustrations as a guide.

Always lubricate the deck thoroughly before taking it to the field. Use a pressure lubricating gun.

Be sure all fittings are free from dirt and paint so the lubricant is certain to enter the bearing.

Always force the lubricant through the full length of each bearing until it emerges at the end, carrying with it the worn lubricant and any dirt that may have entered the bearing.

Miscellaneous working parts not provided with lubrication fittings should be oiled daily with a good grade of lubricating oil.

Lubricant is cheap. Use plenty of it. Worn parts can be expensive to replace.

Keep your supply of lubricating oil and grease stored in clean containers, and covered to protect from dust and dirt.

Keep the lubricating gun nozzle clean and wipe dirt from grease fittings before lubricating.

The symbol in the illustration indicates the method of application and the hourly intervals to apply the lubricant.



Use a pressure lubricating gun and apply 251H EP grease (or equivalent No. 2 multipurpose lithium grease) sufficient to flush out the old grease and dirt. Lubricate at hourly intervals indicated on symbol.

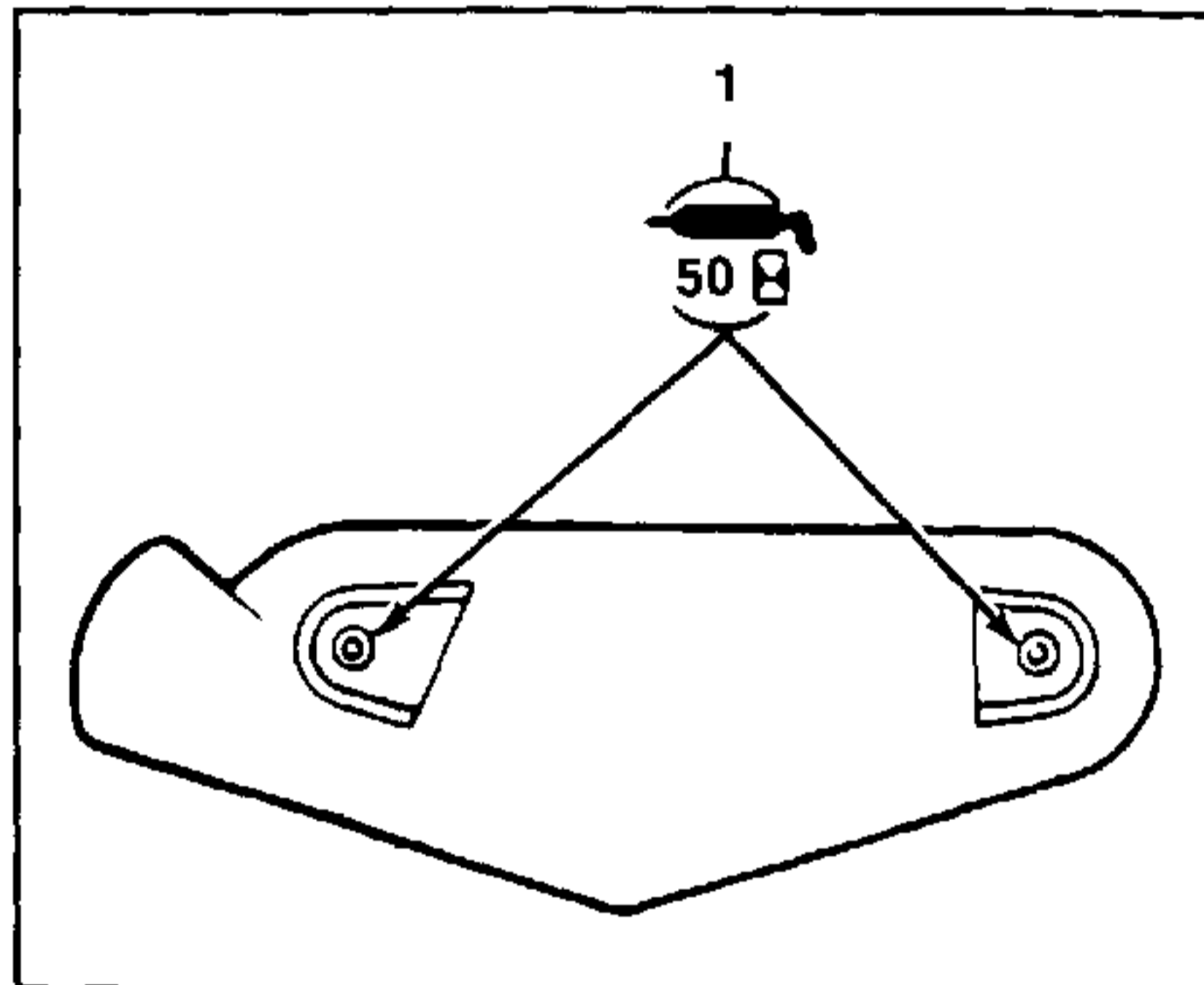

(38 Inch Deck)

1. Deck Spindles

—EVERY 50 HOURS OF OPERATION

Use 251H EP grease or equivalent No. 2 multipurpose lithium grease and apply sufficient grease to flush out old grease and dirt.

SECTION II. TRACTOR PREPARATION

1. Remove bolts and washers from reinforcement rod assembly.
2. Assemble reinforcement rod to middle hole in front hanger bracket on tractor as shown in figure 2.
3. Refer to figure 3. Remove cotter pins and flat washers attaching existing connecting links on tractor. Remove links and discard. Save cotter pins and flat washers.

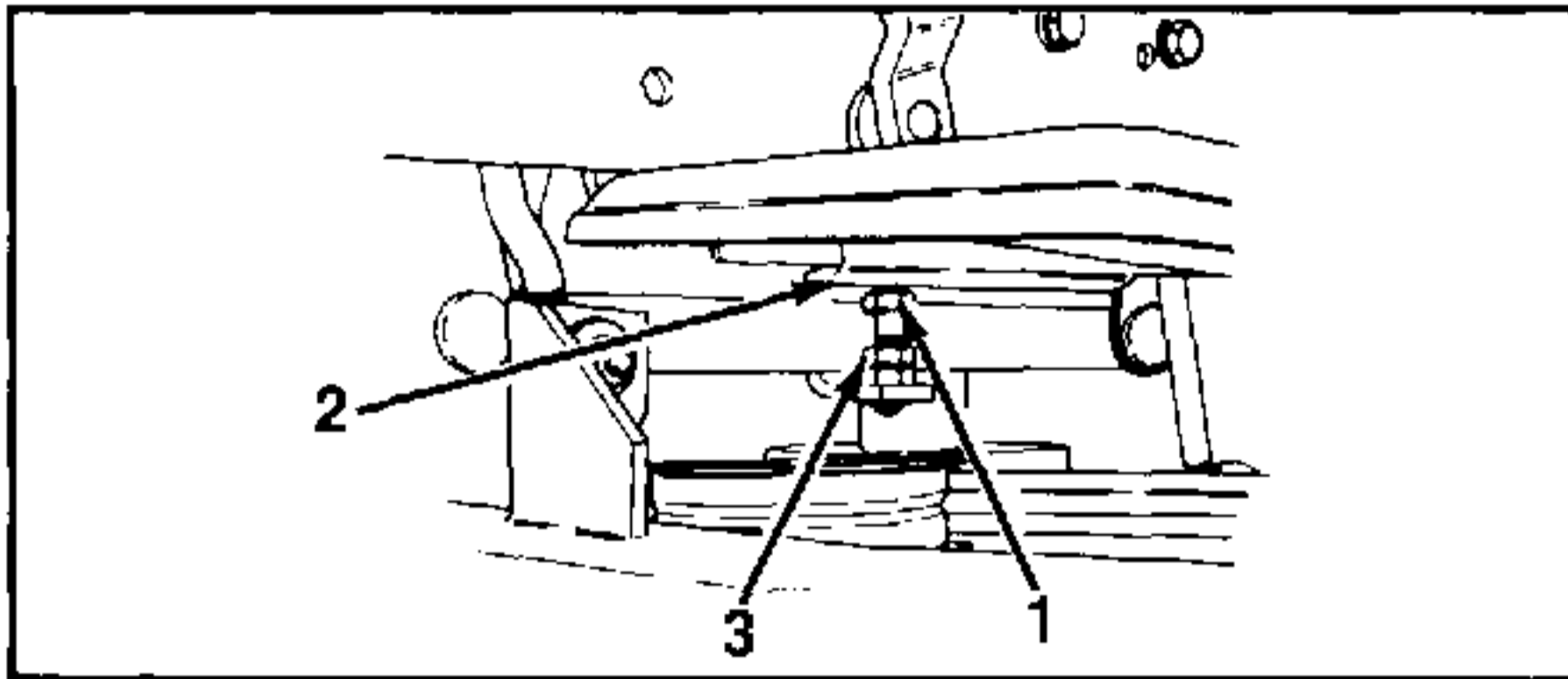

FIGURE 2.

- | | |
|----------------------|-----------|
| 1. Reinforcement Rod | 3. Washer |
| 2. Bolt | |

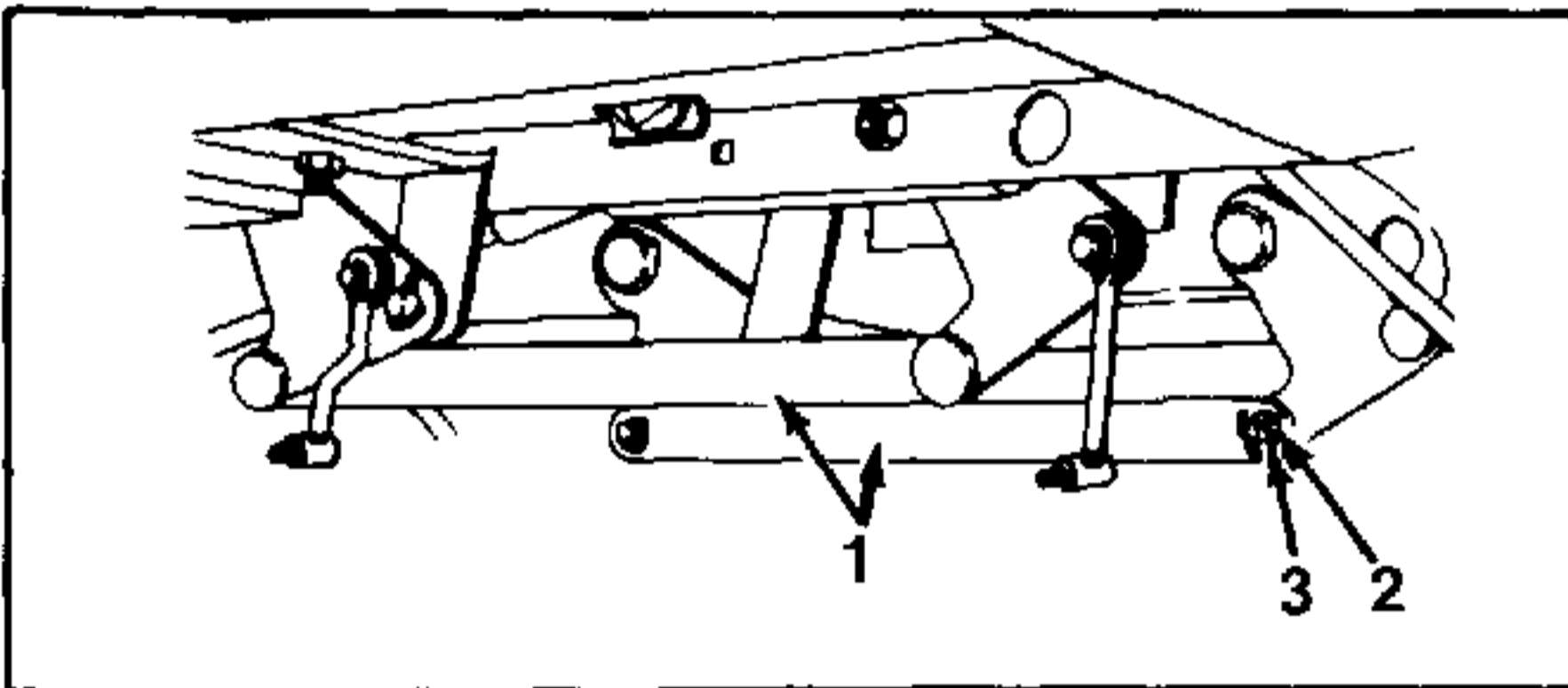

FIGURE 3.

- | | |
|---------------------|----------------|
| 1. Connecting Links | 3. Flat Washer |
| 2. Cotter Pin | |

4. Refer to figure 4. With cotter pins and flat washers left from removal of connecting links, assemble lift stop assemblies in place of connecting links.
5. Raise the lift handle to its highest setting as shown in figure 9, and make sure the head of stop bolt is touching frame. See figure 5.
6. If necessary, loosen jam nut and turn bolt until it touches frame. Tighten jam nut.

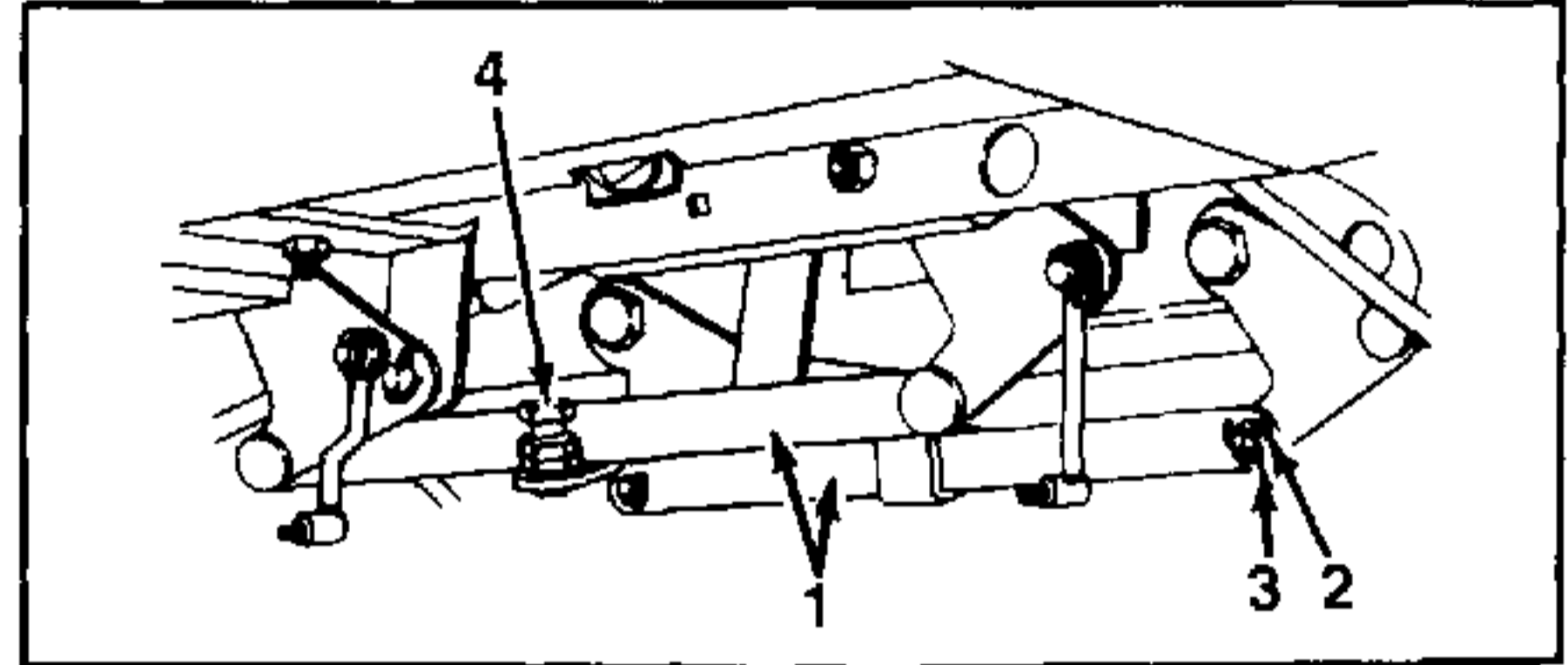

FIGURE 4.

- | | |
|-------------------------|----------------|
| 1. Lift Stop Assemblies | 3. Flat Washer |
| 2. Cotter Pin | 4. Stop Bolt |

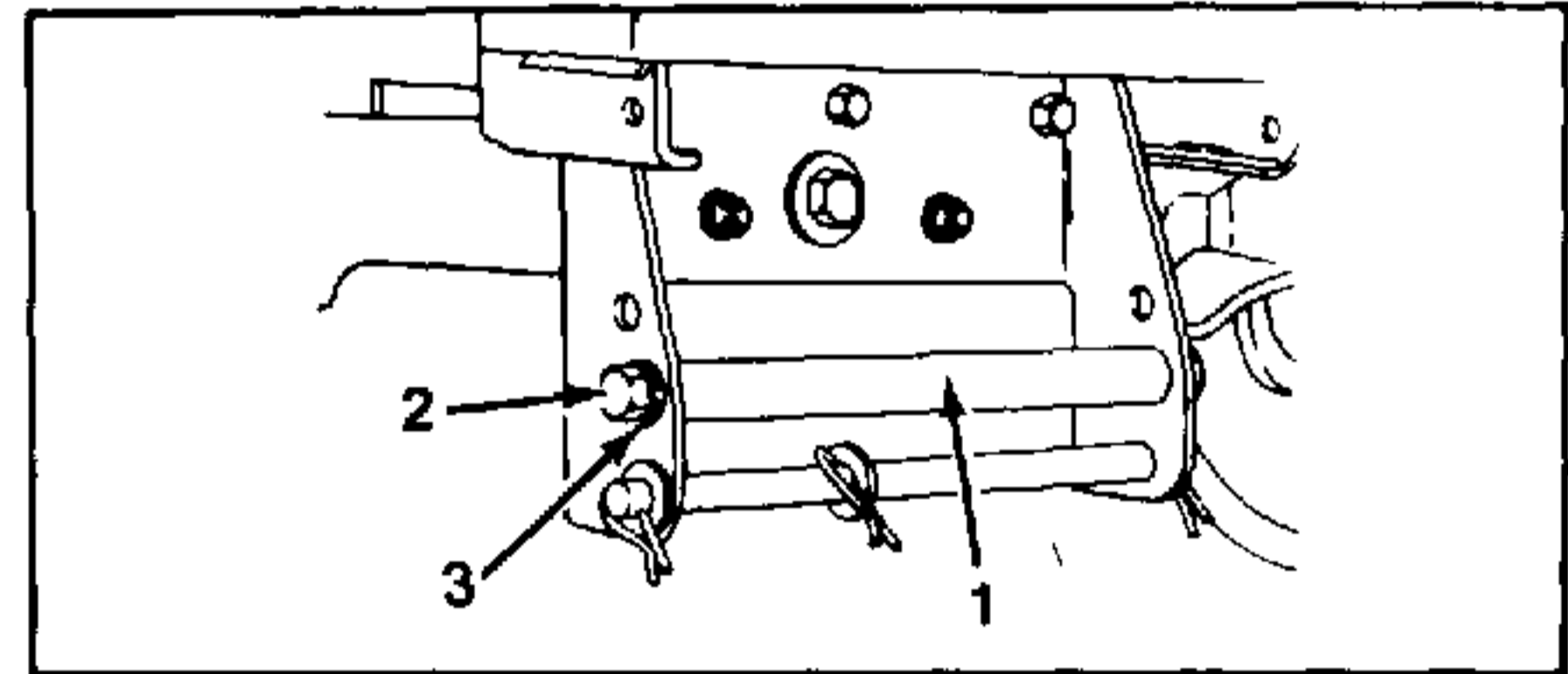

FIGURE 5.

- | | |
|--------------|------------|
| 1. Stop Bolt | 3. Jam Nut |
| 2. Frame | |

SECTION III. INSTALLATION AND REMOVAL OF DECK ASSEMBLY

A. PREPARATION

Prior to beginning installation of the deck, refer to figure 1 and complete the following preparations:

1. Remove the hairpin cotter and the flat washer from the end of the deck hanger rod. Remove the deck hanger rod.
2. **Note the relative position of the right rear ferrule to the lift bracket.** Remove the center lock nuts and flat washers securing the ferrules. Remove the front and rear ferrules from the deck.
3. In order to facilitate sliding the deck under the tractor, the ball wheels and gauge wheels must first be turned inward 90 degrees and set in the lowest position. Refer to figure 6 and position each wheel as shown, by first retracting the quick release pin. Resecure each wheel with a quick release pin.

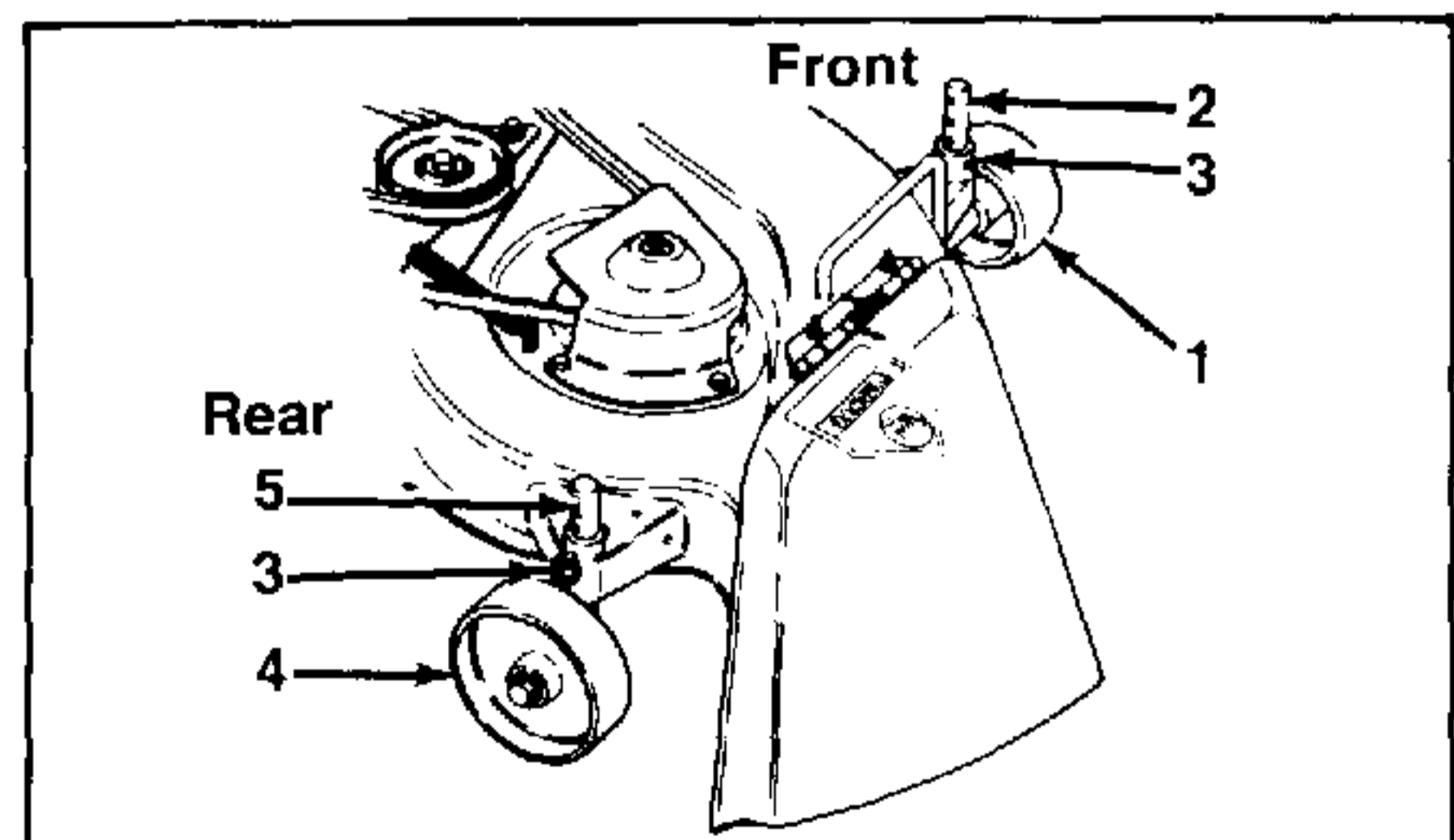

FIGURE 6.

- | |
|----------------------------------|
| 1. Ball Wheel |
| 2. Ball Wheel Adjusting Bracket |
| 3. Quick Release Pin |
| 4. Gauge Wheel |
| 5. Gauge Wheel Adjusting Bracket |

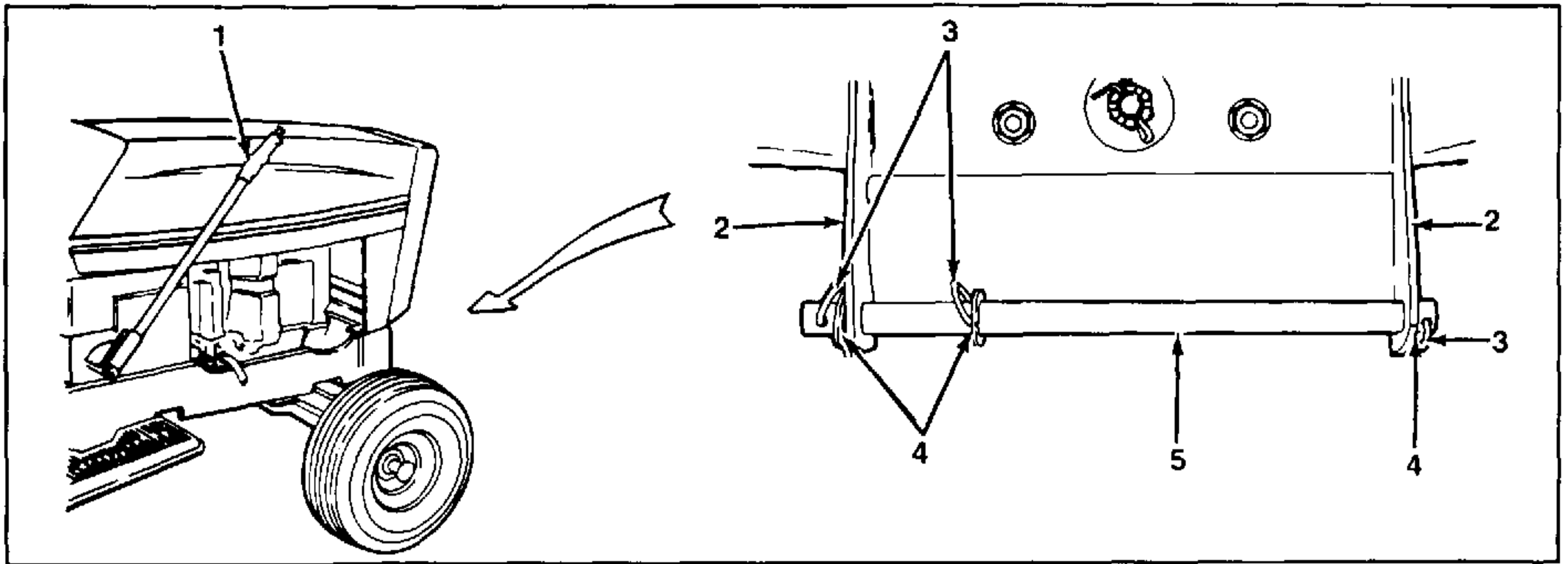

FIGURE 7.

1. Lift Handle
2. Front Hanger Bracket
3. Hairpin Cotter

4. Flat Washer
5. Front Bracket Rod

B. INSTALLATION OF DECK



WARNING

Stop the tractor engine, disengage the PTO, place all controls in neutral and engage the brake pedal lock before performing deck installation.



WARNING

When handling the mower deck, be careful not to cut yourself on the sharp blades.



CAUTION

The mower deck must be placed on a hard level surface during installation.

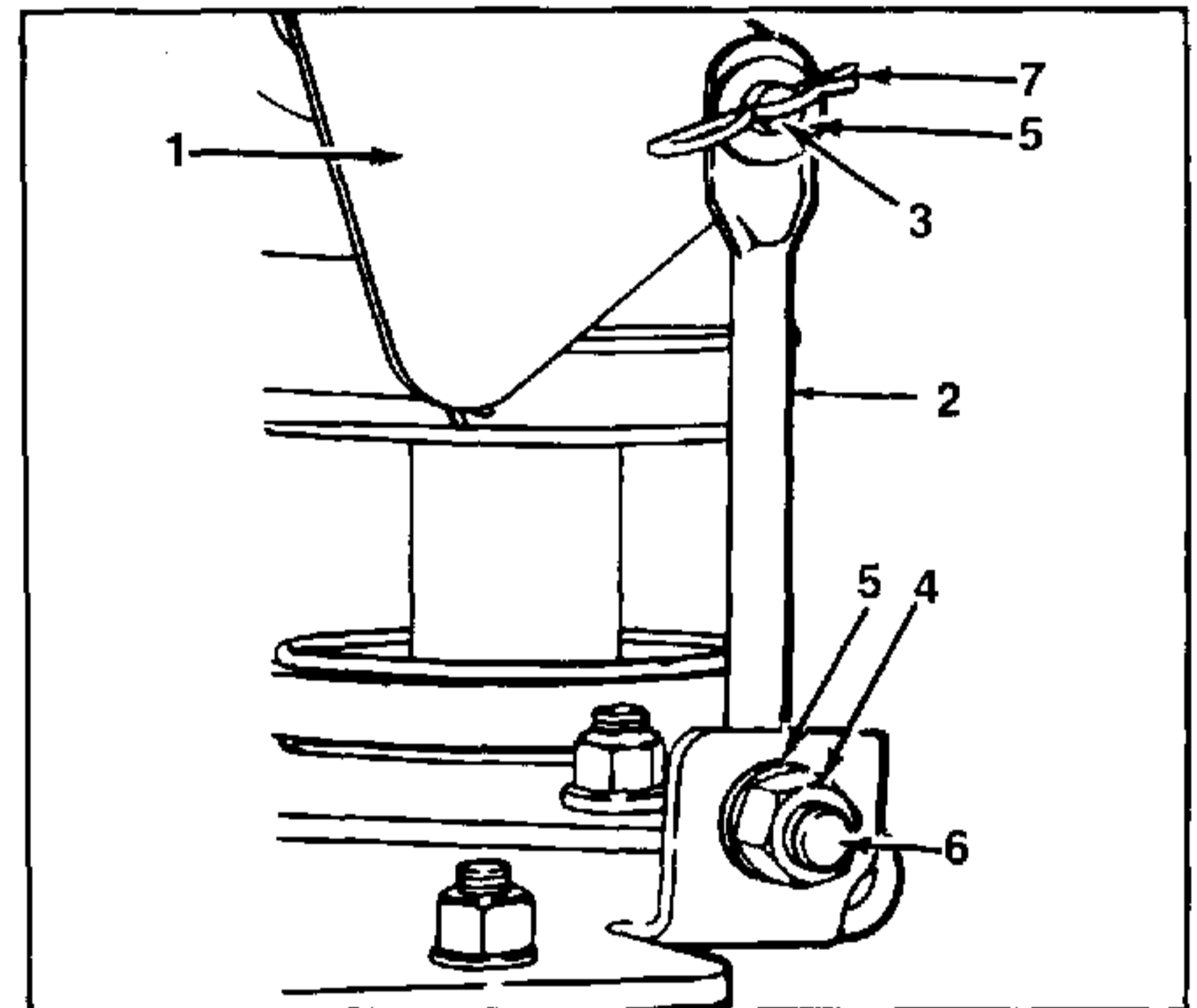

FIGURE 8.

- | | |
|--------------------|-------------------|
| 1. Lift Carriage | 5. Flat Washer |
| 2. Rear Lift Link | 6. Ferrule |
| 3. Lift Pin | 7. Hairpin Cotter |
| 4. Center Lock Nut | |

Proceed with deck installation as follows:

1. Refer to figure 7. Using the steering wheel, turn the left front wheel to the left as far as possible. Remove the hairpin cotters from the right end and from the center of the tractor hanger rod. Withdraw the rod from the front hanger bracket. Collect the washers.
2. Place the lift handle at its lowest setting.
3. Refer to figure 8. Note the relative position of the flat area at the top of the two rear lift links, to the welded lift pins on the lift carriage. Remove the hairpin cotters and flat washers which attach the rear lift links to the lift pins. Remove the two rear lift links.



CAUTION

Be careful not to hit the hydrostatic linkage with the wheel adjustment brackets when sliding the deck in or out.

4. Raise the lift handle to its highest setting. Refer to figure 9 and place the deck on the right side of the tractor, with the front of the deck facing toward the front of the tractor. Slide the deck under the tractor until it is aligned with the tractor as illustrated in figure 10.

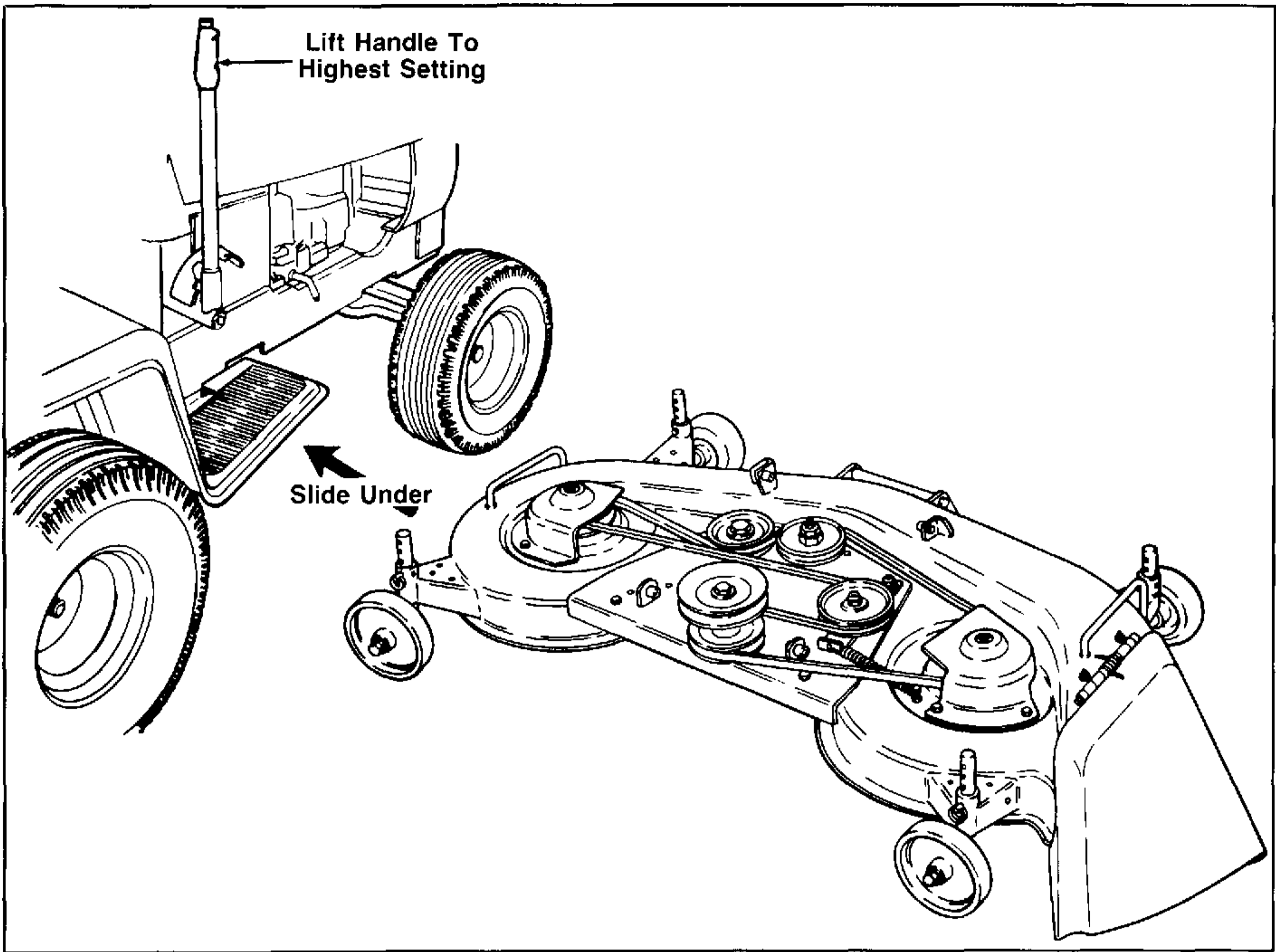

FIGURE 9.

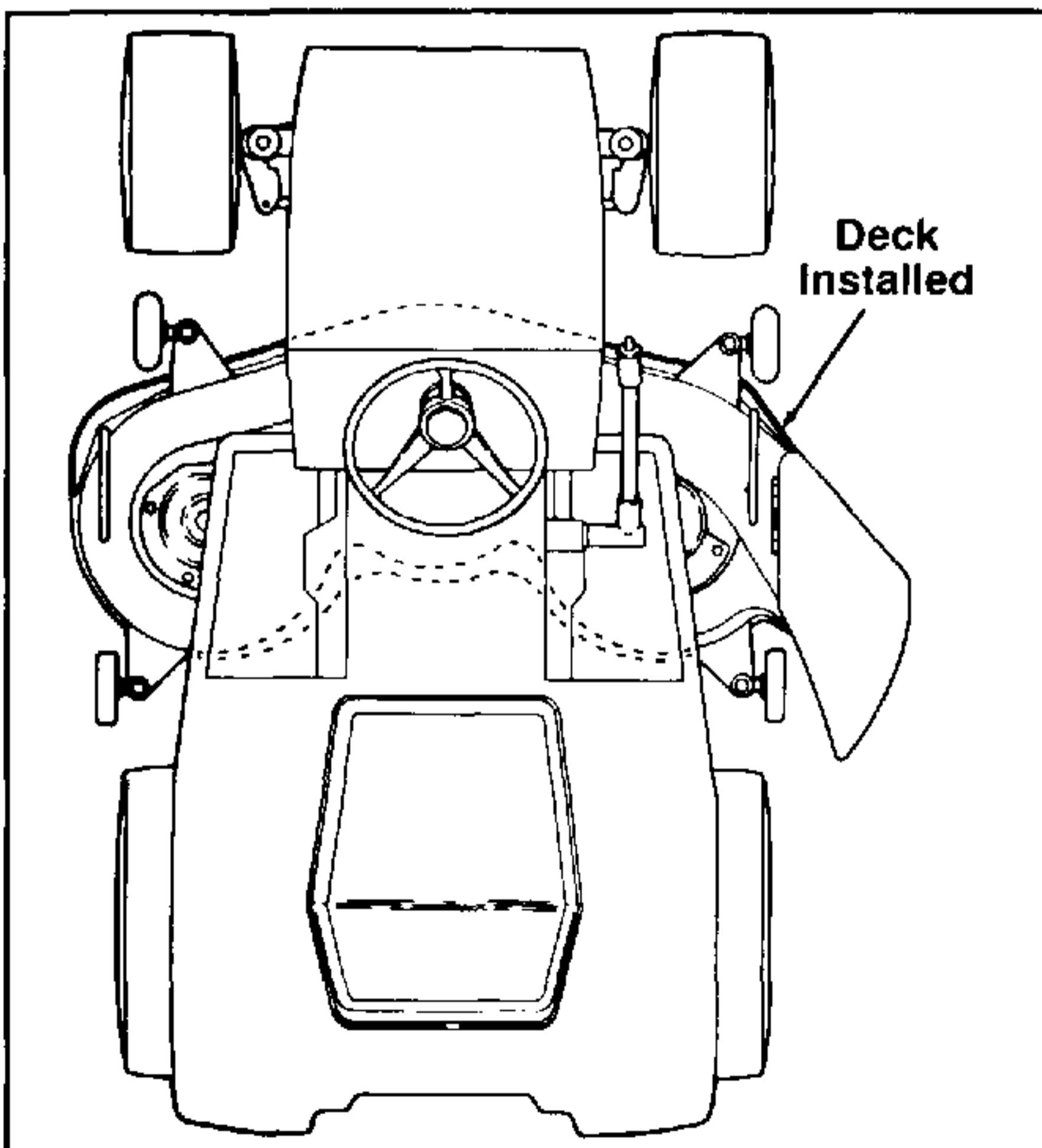

FIGURE 10.

5. Refer to figure 11. Lift the right end of the deck, and set the outside spindle nut on the face of a six inch long 2" x 4" wooden block (obtained from a wooden building stud). Repeat this step for the left and center spindles.
6. Lower the lift handle to position number 2. Screw a ferrule onto each of the rear lift links. Secure each of the rear lift links to the lift carriage lift pins using a flat washer and hairpin cotter.
7. Adjust the ferrules on the rear lift links so that the small end of the ferrule lines up with the holes in the deck bracket. **When performing this step recall the relative position of the right rear ferrule to the deck bracket.** Secure each of the rear ferrules to the deck brackets using a flat washer and a center lock nut.

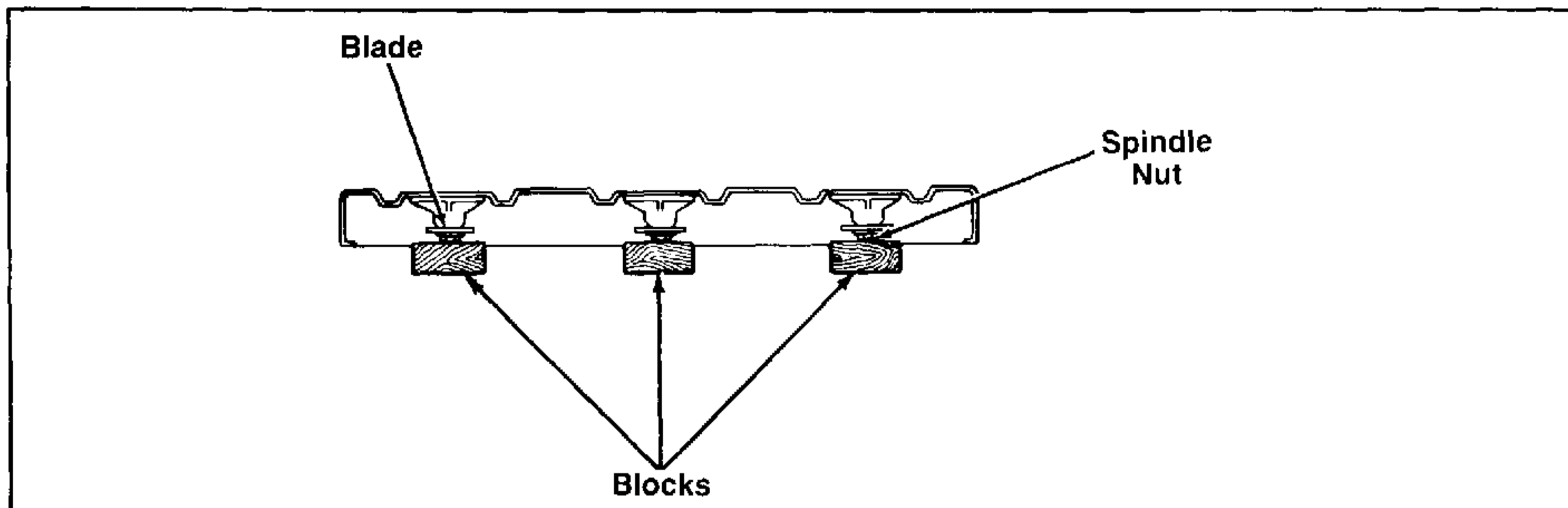

FIGURE 11.

8. Screw on and position ferrules to the front lift links. Refer to figure 12 and secure the links to the front deck brackets with flat washers and center lock nuts.
9. Raise the lift handle to its highest setting. Reposition the ball wheels and the gauge wheels as shown in figure 10 by first retracting the quick release pin and then rotating each wheel outward 90 degrees. Wheels must remain at lowest position at this time. Resecure each wheel with a quick release pin.

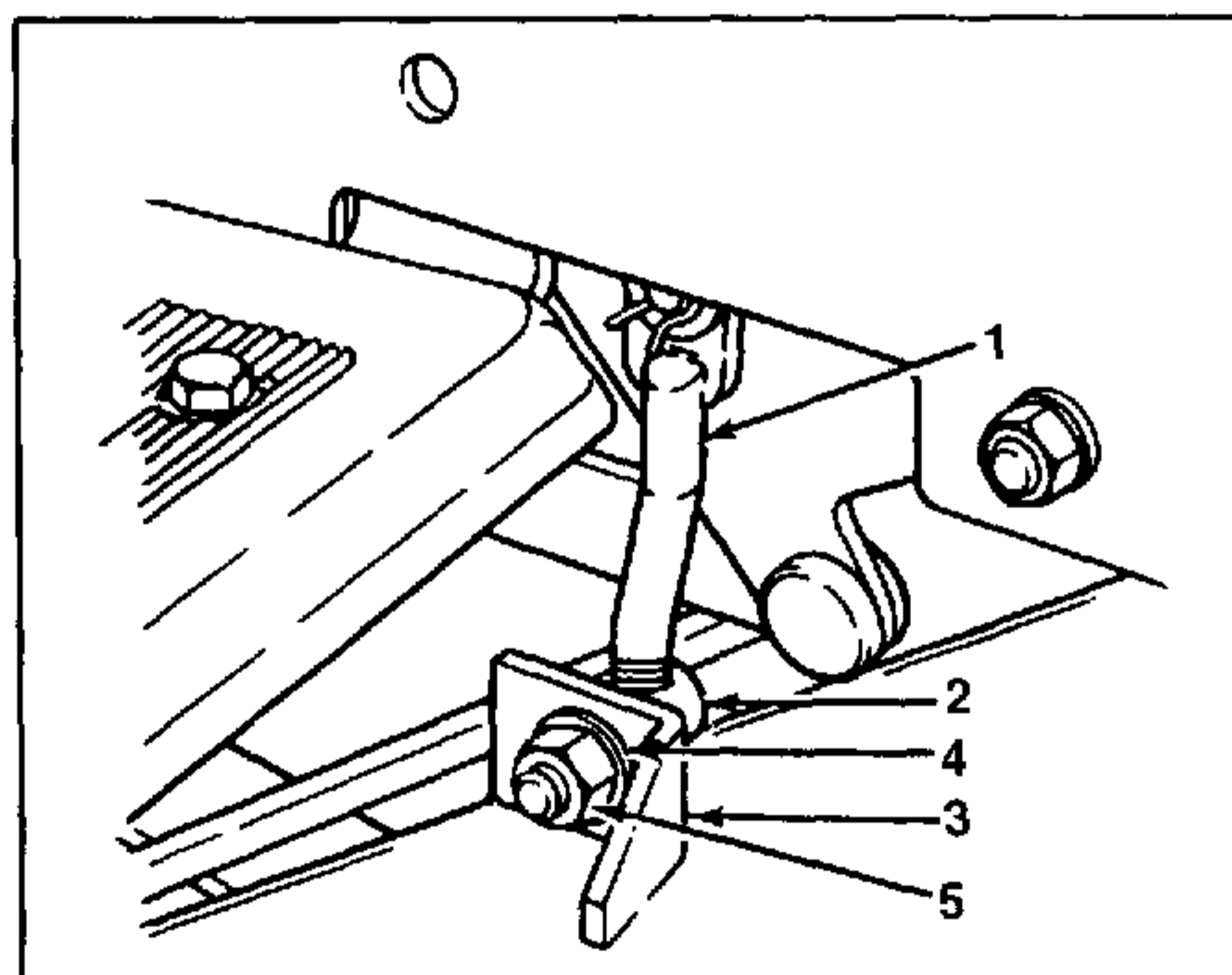

FIGURE 12.

1. Front Lift Link
 2. Ferrule
 3. Front Deck Bracket
 4. Flat Washer
 5. Center Lock Nut
10. Refer to figure 13 to determine the proper positioning of the front hanger assembly in relation to the tractor and deck. Note that when the front hanger

assembly is properly positioned, the hanger extensions face the rear of the tractor, and the top of the front hanger assembly is open. Attach the rear of the front hanger assembly to the top hole of the front roller bracket using the deck hanger rod. Secure the rod to the bracket using a flat washer and hairpin cotter.

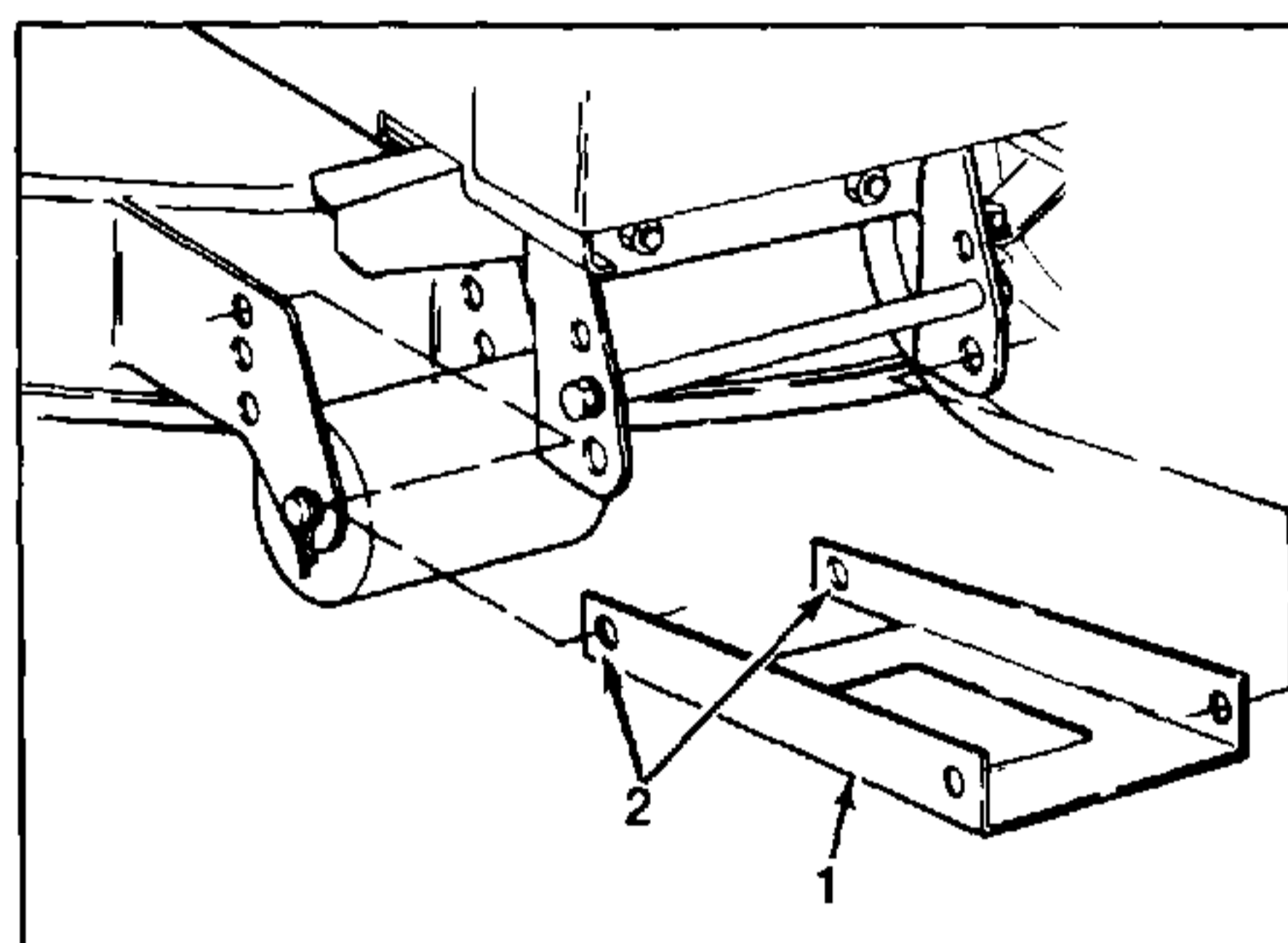

FIGURE 13.

1. Front Hanger Assembly
2. Hanger Extension

11. With the left front wheel turned to the left, attach the front hanger assembly to the front hanger bracket by passing the tractor hanger rod through the bottom mounting holes of the front hanger bracket. Remember to attach the center flat washer to the rod after it passes through the right side of the front hanger assembly. Refer to figure 14. Secure the tractor hanger rod with flat washer and hairpin cotters.
12. Install front PTO drive belt on upper pulley of double drive pulley on deck.

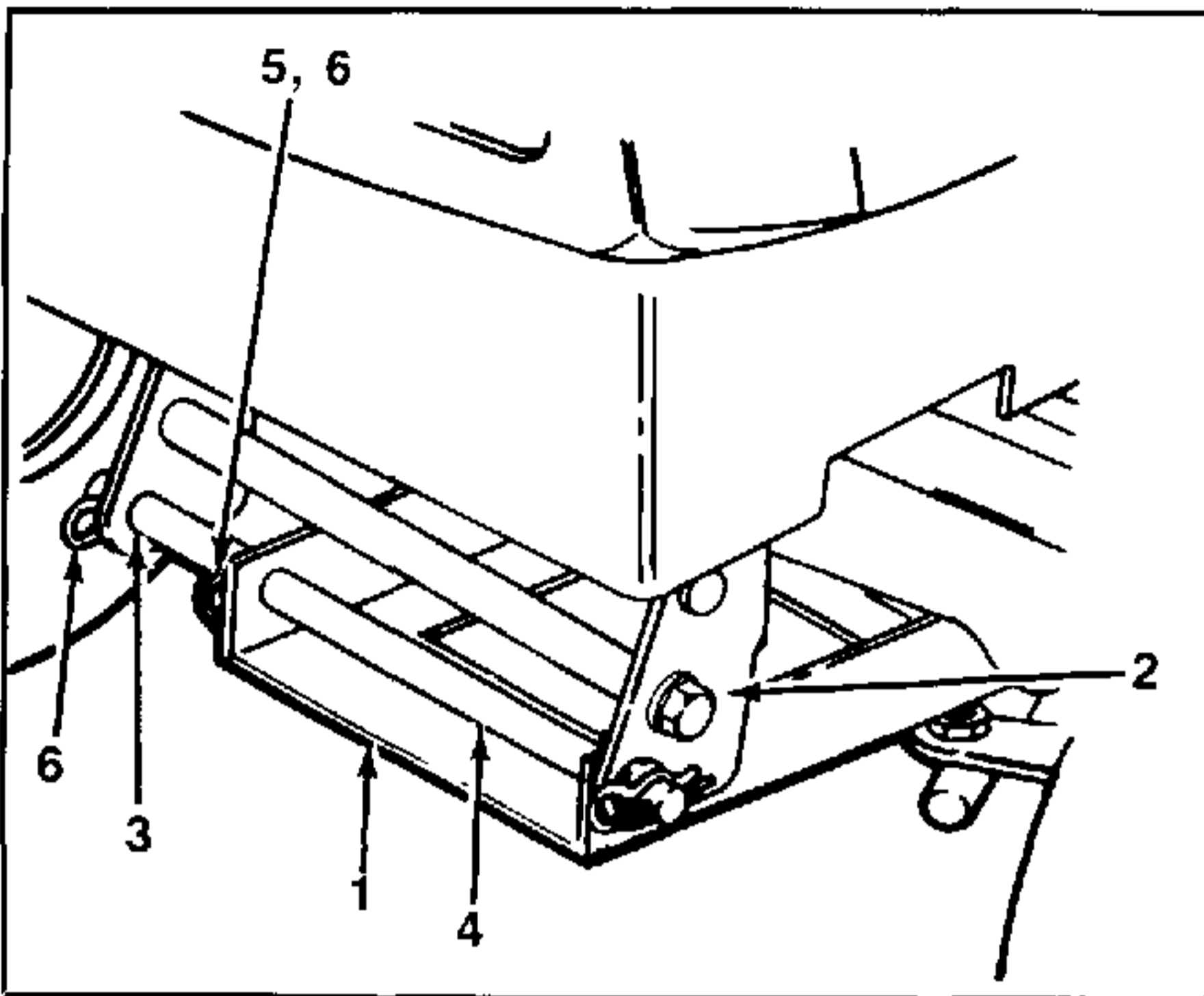

FIGURE 14.

1. Front Hanger Assembly
2. Front Hanger Bracket
3. Bottom Mounting Hole
4. Tractor Hanger Rod
5. Center Flat Washer
6. Hairpin Cotter

13. Slip drive belt electric PTO pulley on tractor. Refer to figure 15.

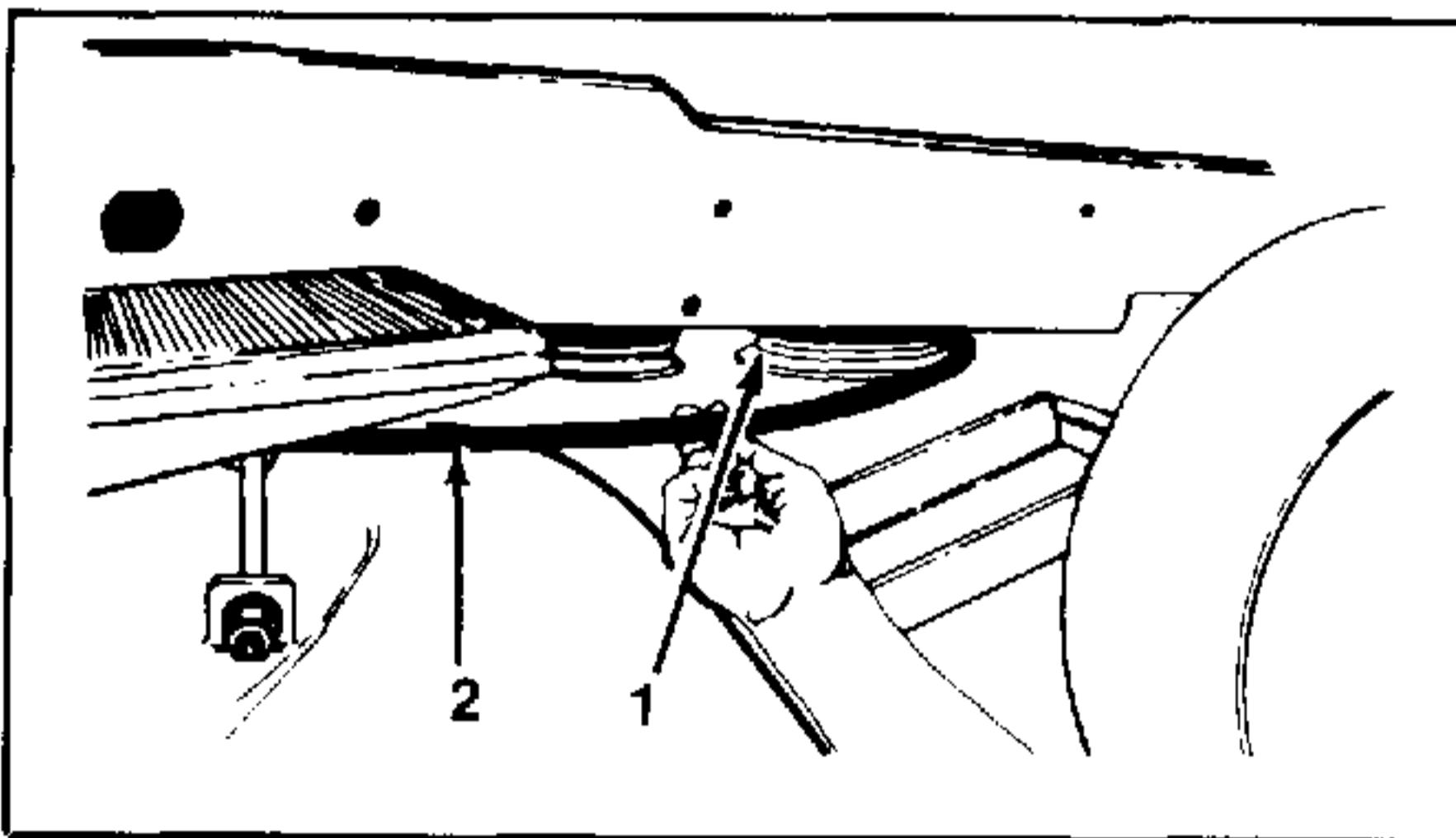

FIGURE 15.

1. Electric PTO Pulley
2. Front PTO Drive Belt

14. Pull idler pulley away from the tractor and then place drive belt behind it. Release idler pulley. Refer to figure 16.

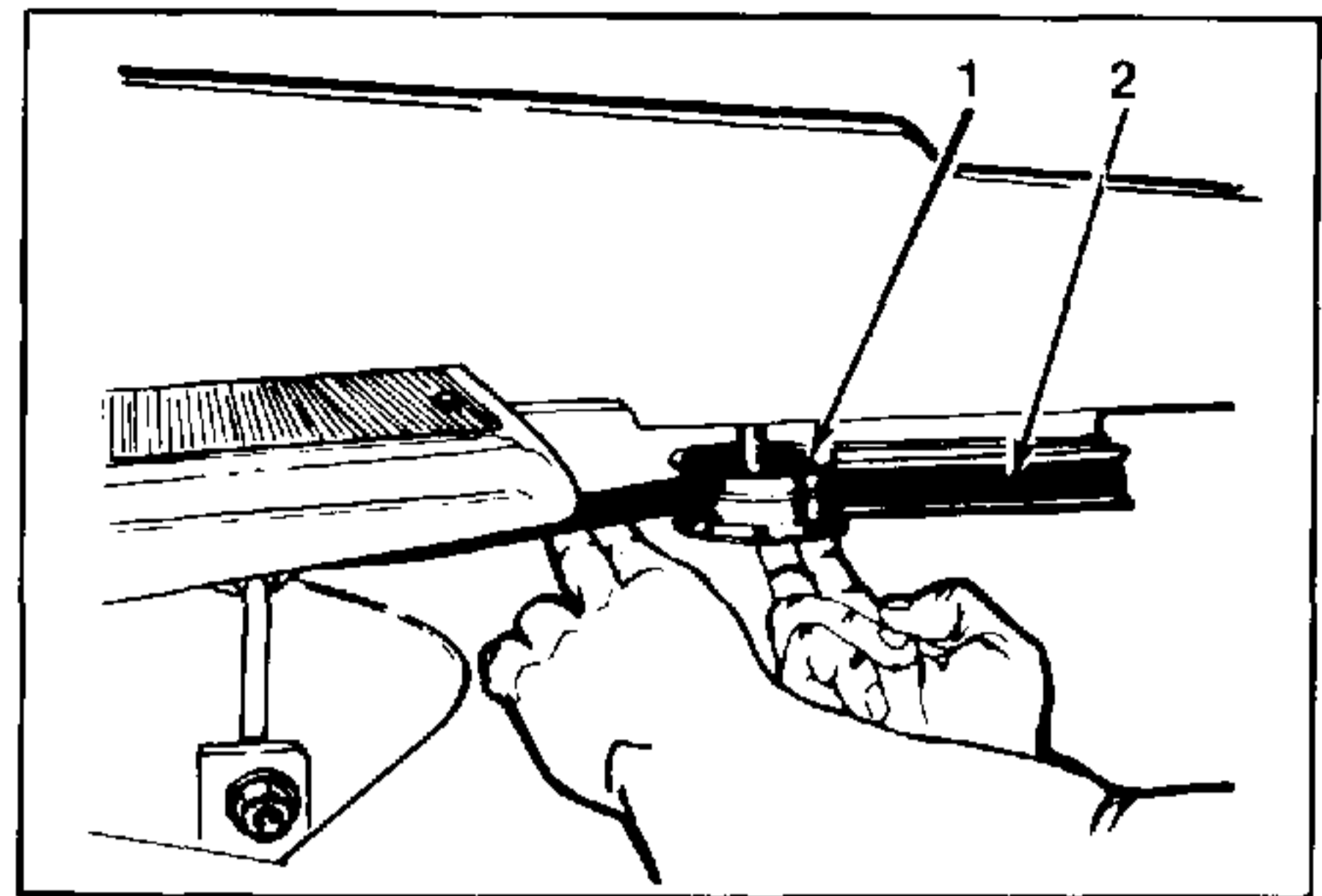

FIGURE 16.

1. Idler Pulley
2. Front PTO Drive Belt

C. REMOVAL OF DECK



WARNING

Stop the tractor engine, disengage the PTO, place all controls in neutral and engage the parking brake before performing deck removal.



WARNING

When handling the mower deck, be careful not to cut yourself on the sharp blades.



CAUTION

The mower deck must be placed on a hard level surface during removal.



CAUTION

Be careful not to hit the hydrostatic linkage with the wheel adjustment brackets when sliding the deck in or out.

Removal of the deck is achieved by reversing the deck installation procedure described under "INSTALLATION OF DECK" detailed on page 3-32.

SECTION IV. ADJUSTMENTS

A. DECK LEVELING ADJUSTMENTS

In order to achieve even cutting, the mower deck must be properly leveled. This leveling procedure will result in the left and right outside blades having corresponding cutting-edge-to-ground measurements.



WARNING

Before making any adjustments, turn off the machine, remove the key, and engage the brake pedal lock to avoid accidental starting and injury.



WARNING

When adjusting the mower deck, be careful not to cut yourself on the sharp blades.



CAUTION

If the mower deck is not level, the mower will not cut your lawn evenly.



NOTE

Check the tires for proper inflation before making a level adjustment. To level the deck, the tractor **MUST** be placed on a hard, level surface.



NOTE

The middle cutting blade will not be considered when performing the leveling adjustment.

1. Set all gauge wheels and ball wheels to the lowest position as described in step B9 of Section III located on page 3-24.
2. Place the lift handle, figure 17, in position number 6.
3. Disconnect the spark plug wire(s).
4. Position the right and left outside mower blades so that the ends of each blade face the front and rear of the tractor. Refer to figure 18.
5. Refer to figure 19 and measure and record measurement "A" for each of the outside blades. If measurements "A" of the two outside blades are within 1/16" of each other proceed to step 11. If the two measurements "A" are not within 1/16", proceed to step 6.

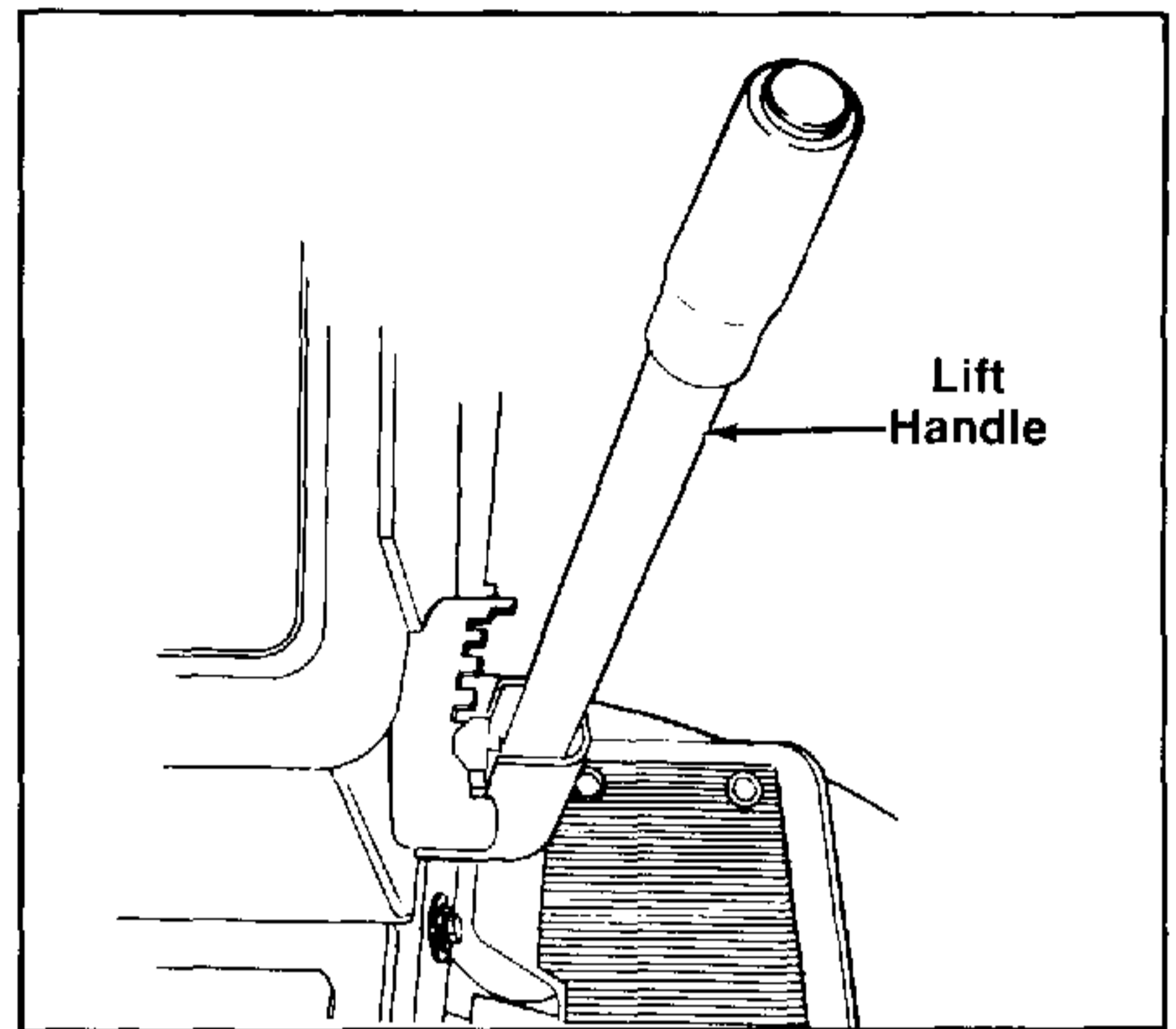

FIGURE 17.

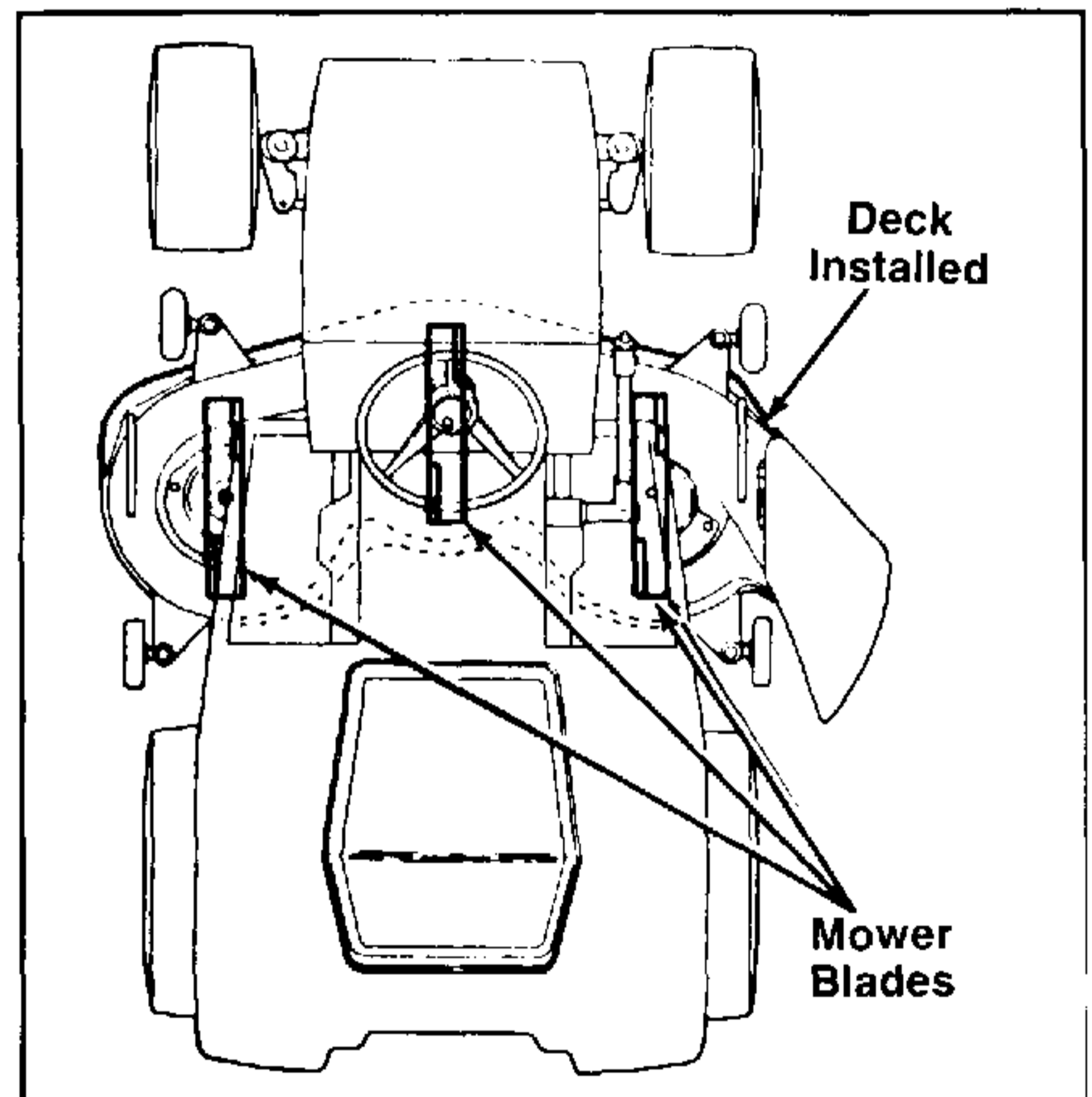

FIGURE 18.

6. Determine which outside blade has the highest front measurement "A". This high blade's front measurement must be lowered to within 1/16" of measurement "A" of the other outside blade.



NOTE

Lowering front blade measurement "A" is achieved using the front lift link located on the same side of the deck as the blade being adjusted.

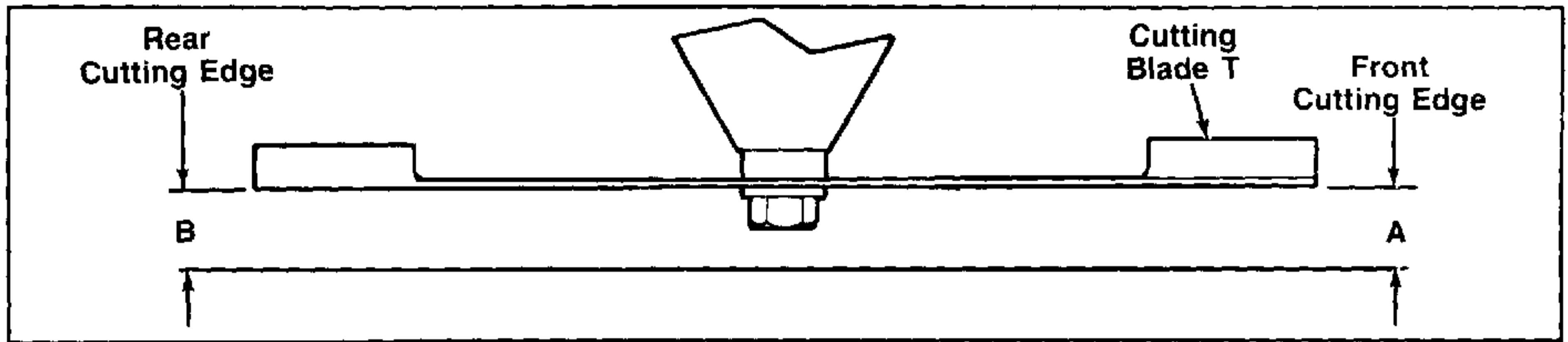

FIGURE 19.

- Place the lift handle in position number 1. Refer to figure 20. Working on the same side of the deck as the blade being adjusted, remove the hairpin cotter and flat washer which secure the front lift link to the lift carriage lift pin. Remove the front lift link from the lift carriage lift pin.

NOTE

Loosening the center lock nut on the ferrule may ease removal of the lift link from the lift pin.

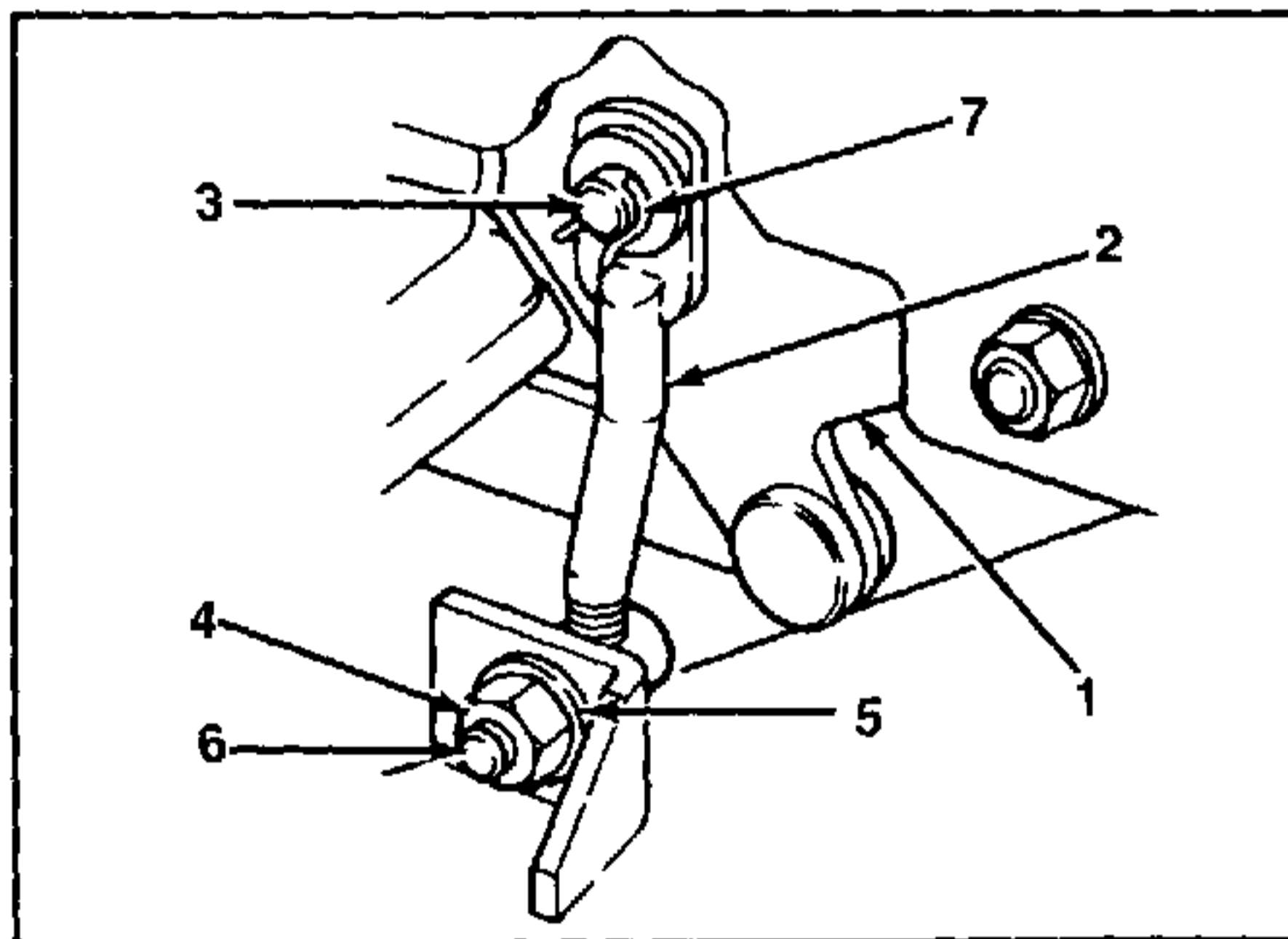

FIGURE 20.

- | | |
|--------------------|-------------------|
| 1. Lift Carriage | 5. Flat Washer |
| 2. Front Lift Link | 6. Ferrule |
| 3. Lift Pin | 7. Hairpin Cotter |
| 4. Center Lock Nut | |

- Turn the lift link counterclockwise (out of the ferrule) until measurement "A" of the high blade is within 1/16" of the opposite outside blade measurement "A".

NOTE

Each 360 degree turn of the lift link alters the front blade height by approximately 1/16".

NOTE

If the deck has been adjusted too low, turning the lift link clockwise (into the ferrule) will raise the deck.

- Place the front lift link onto the lift carriage lift pin, and secure with a flat washer and hairpin cotter. If necessary, retighten the center lock nut on the ferrule.

- Place the lift handle in position number 6. Check that measurement "A" of the adjusted blade is within 1/16" of measurement "A" of the other outside blade. If not, repeat steps 7, 8, 9, and 10 until the desired measurement is achieved.

- Place the lift handle in position number 6. Refer to figure 19 and measure and record measurement "A" and "B" for each of the outside blades. An individual blade is properly level if its front measurement "A" is equal to its rear measurement "B". Proceed to steps 12, 13 and 14 for each blade that is not level.

NOTE

Leveling an individual blade is achieved by adjusting (raising or lowering) the front of the deck until the front blade measurement "A" equals the rear blade measurement "B". This adjustment is accomplished using the front lift link located on the same side of the deck as the blade being removed.

- Place the lift handle in position number 1. Refer to figure 20. Working on the same side of the deck as the blade being adjusted, remove the hairpin cotter and flat washer which secure the front lift link to the lift carriage lift pin. Remove the front lift link from the lift carriage lift pin.

NOTE

If measurement "A" must be LOWERED, refer to step 12.a. If measurement "A" must be RAISED, refer to step 12.b.

NOTE

Loosening the center lock nut on the ferrule may ease removal of the lift link from the lift pin.

- a. Turn the lift link counterclockwise (out of the ferrule) until measurement "A" is equal to measurement "B".

➔ NOTE

Each 360 degree turn of the lift link alters the front blade height by approximately 1/16".

- b. Turn the lift link clockwise (into the ferrule) until measurement "A" is equal to measurement "B".
13. Place the front lift link into the lift carriage lift pin and secure with a flat washer and hairpin cotter. If necessary, retighten the center lock nut on the ferrule.
14. Place the lift handle in position number 6. Check that measurement "A" of the adjusted blade is equal to measurement "B" of that blade. If measurement "A" and "B" of the adjusted blade are not equal, repeat steps 12, 13, and 14 until the desired measurement is achieved.

B. BALL WHEELS AND GAUGE WHEELS



WARNING

Before making any adjustments, turn off the machine, remove the key and engage the brake pedal lock to avoid accidental starting and injury.



WARNING

When handling the mower deck, be careful not to cut yourself on the sharp blades.

➔ NOTE

Wheel height adjustment should be done only AFTER the deck has been properly installed.

In order to adjust the height of the ball wheels and gauge wheels, proceed as follows:

1. Raise the lift handle to its highest setting in order to release pressure on the deck wheels.
2. Pull out the quick release pin.
3. With pin pulled out, slide the ball wheel or gauge wheel bracket up or down until desired height is reached.
4. Reinsert the quick release pin.

5. Lower lift handle and check for proper wheel adjustment. If adjustment is not adequate, repeat steps 1 through 5.

➔ NOTE

All deck wheels must be set in the same relative hole locations. Refer to figure 21.

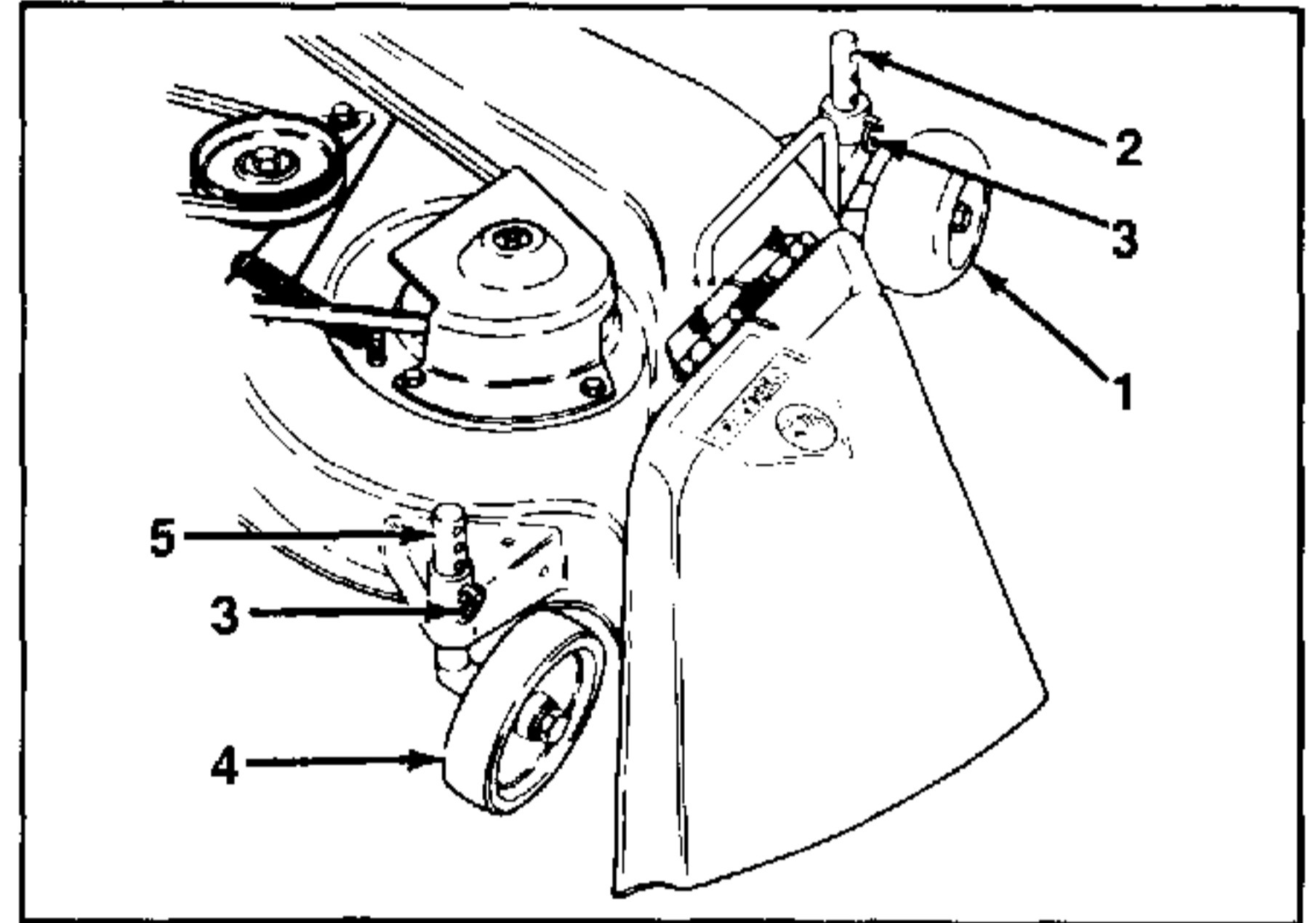

FIGURE 21.

1. Ball Wheel
2. Ball Wheel Adjusting Bracket
3. Quick Release Pin
4. Gauge Wheel
5. Gauge Wheel Adjusting Bracket

CUTTING HEIGHT

The mower can be set in multiple positions. Proceed as follows:

➔ NOTE

Check the tires for proper inflation before making a height adjustment.

1. Pull the lift handle back slightly and depress the button on the top of the lift handle.
2. Release the button when the desired mower position is obtained.

➔ NOTE

To return the mower to a specific position, note position of the lift lever indicator in relation to the lever position decal before raising or lowering the mower.

SECTION V. MAINTENANCE

A. CLEANING AND BLADE CARE



WARNING

Stop the tractor, disengage the PTO, place all controls in neutral, engage the parking brake lock and stop the engine before performing any maintenance.



WARNING

Be careful not to cut yourself when sharpening the blades or cleaning the underside of the mower.

Clean the underside of the mower deck at the end of the mowing season and when buildup of cut material on the underside is noticed. Also remove the belt cover and remove any accumulation.

The cutting blades must be kept sharp at all times.

➔ NOTE

Sharpen ends evenly so that the blades remain balanced and the same angle of sharpness is maintained. However, if the cutting edge of a blade has been sharpened to within 3/8 inch of the wind wing, it is recommended that new blades be installed. New blades are available at your authorized dealer.

When removing the blades, hold the hex shaped pulley hub with a 1-1/8 inch socket wrench to remove the hex nut holding the blade. A block of wood may be placed between housing and cutting edge of blade to assist in removal of hex nut securing blade. Refer to figure 22.

After replacing blades, grease the threaded end of the shaft to prevent rust buildup.

When replacing the blades, be sure they are assembled so the cutting edges are in the direction of rotation with the wind wings pointed upward. Tighten the nuts 50 to 60 ft.-lbs. (68 to 81 N•m).

➔ NOTE

If the spindle pulley nuts are removed for any reason, they should be retightened to 90 to 110 ft.-lbs. (122 to 149 N•m) torque when replaced.

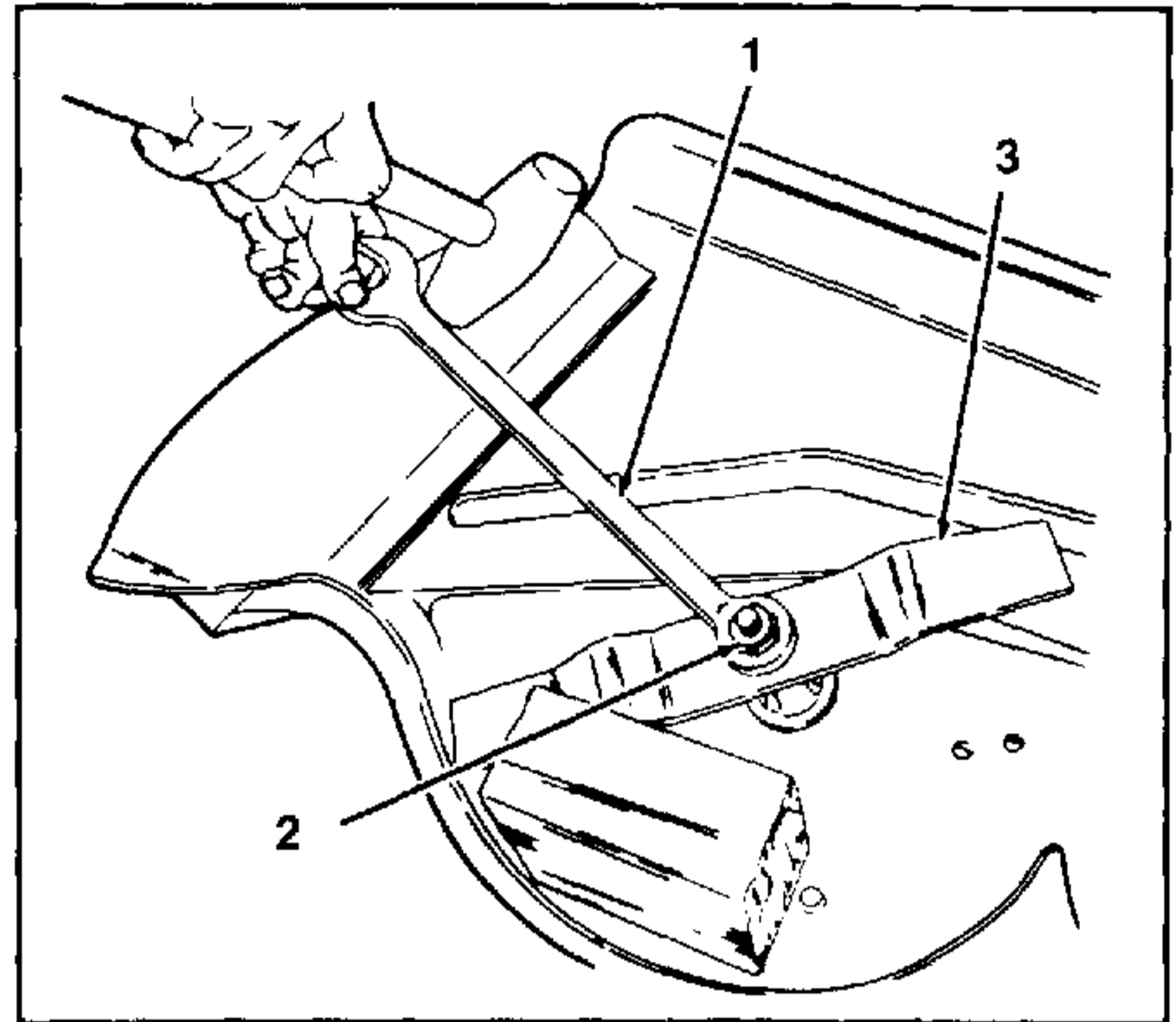

FIGURE 22.

1. 1-1/8 Inch Wrench
2. Hex Nut
3. Blade

B. LUBRICATION

After every 50 hours of operation and/or before putting into winter storage, lubricate the spindle assemblies using 251H EP grease or equivalent No. 2 multipurpose lithium grease. The grease will be expelled from the top spindle seal. Since the spindle pulley covers the top spindle seal, the expelled grease cannot be seen. When the spindle is fully greased, the expelled grease will cause the top spindle seal to give off a muffled crackling noise. Refer to figure 23.

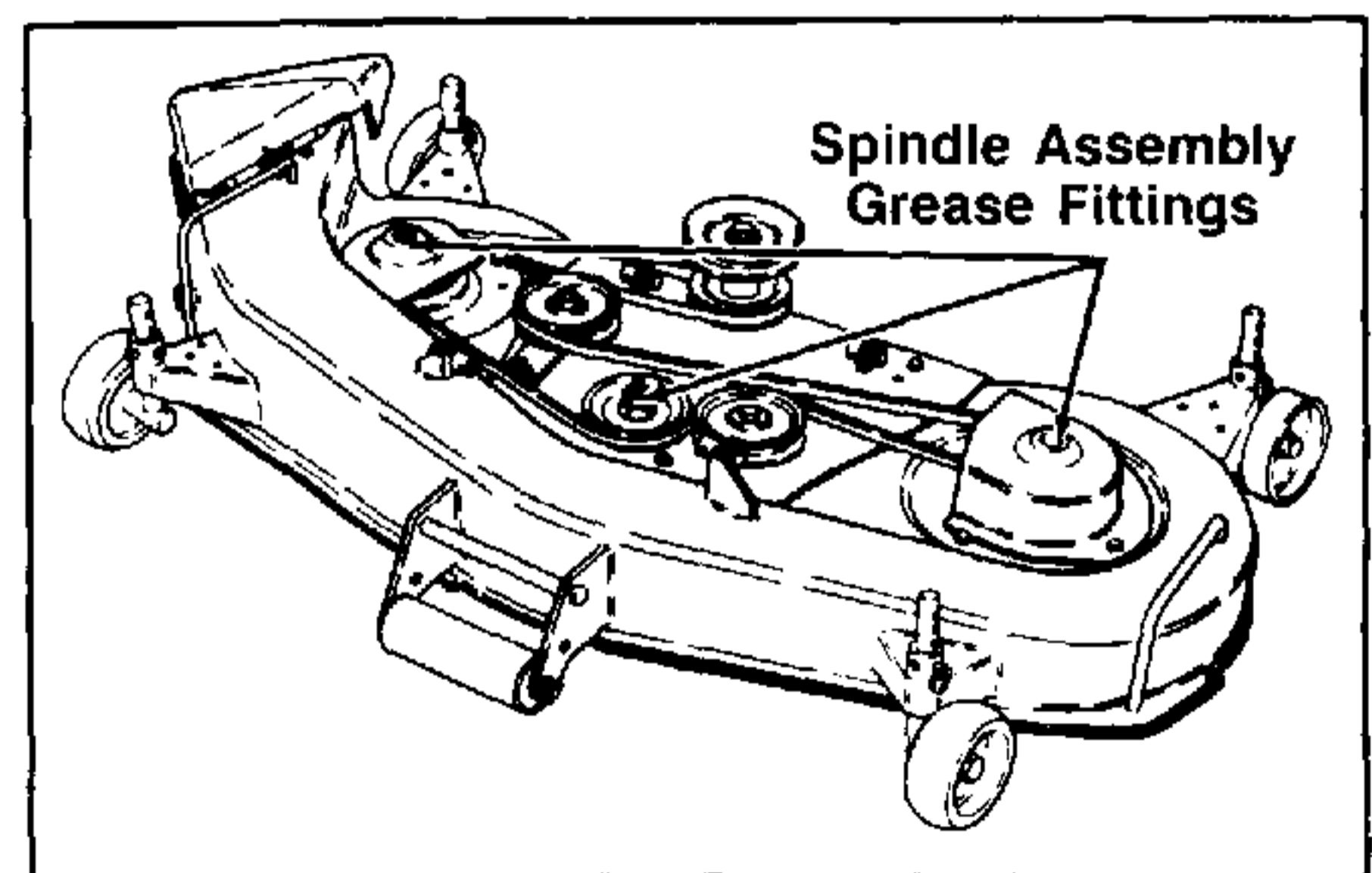

FIGURE 23.

C. SPINDLE DRIVE BELT REPLACEMENT

In order to replace the spindle drive belt, refer to figures 24, 25, and 26 and proceed as follows:

1. Remove the nuts and washers that secure both spindle belt covers to the deck.
2. Remove the spindle belt covers to expose the belt.
3. Push against the idler pulley to release tension on drive belt.
4. Remove old drive belt.
5. Install a new belt. Refer to figures 24, 25, and 26 for proper placement of belt. Push against idler pulley to aid the installation.
6. Reinstall spindle belt covers and hardware.

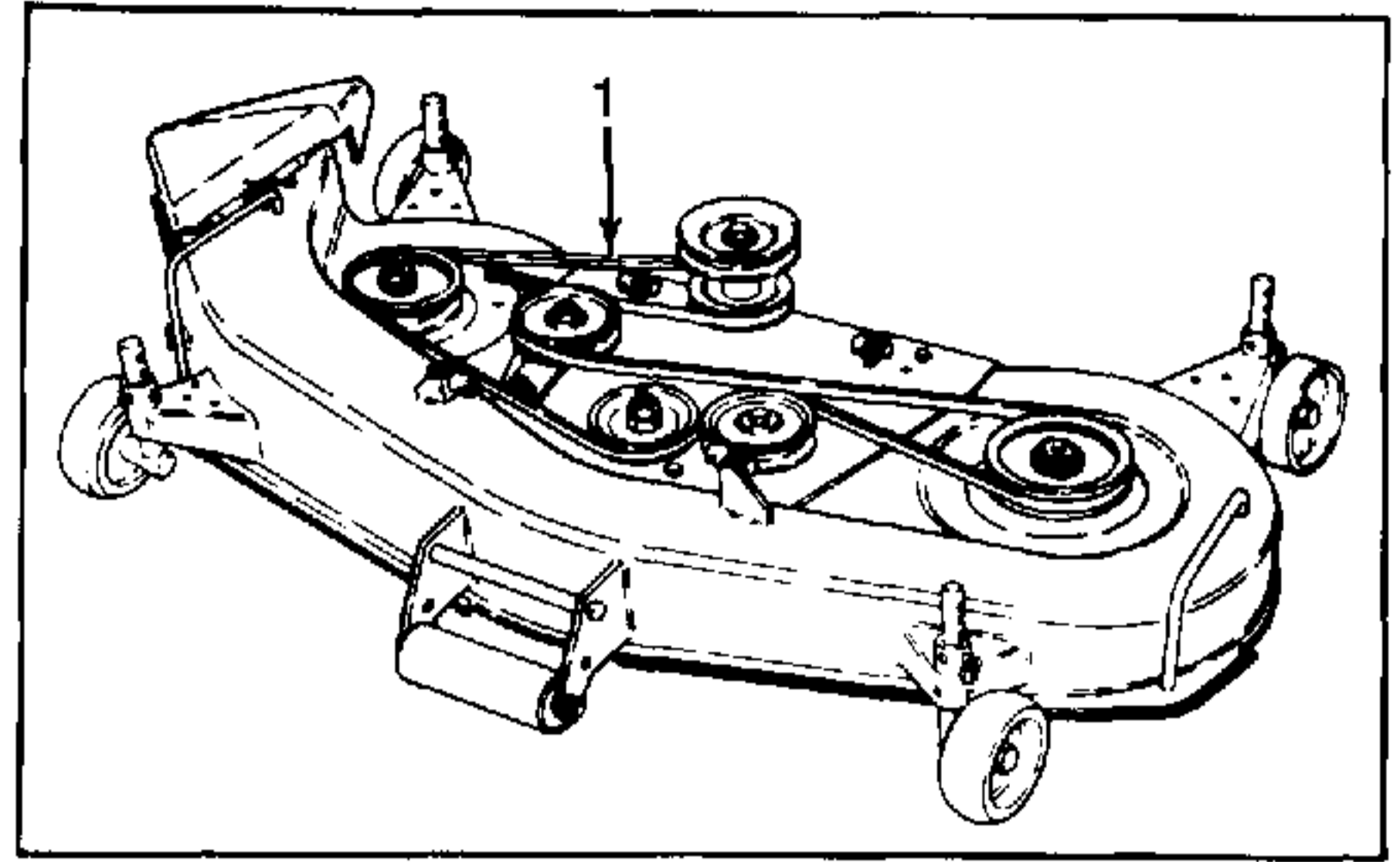

FIGURE 25.

1. Spindle Drive Belt

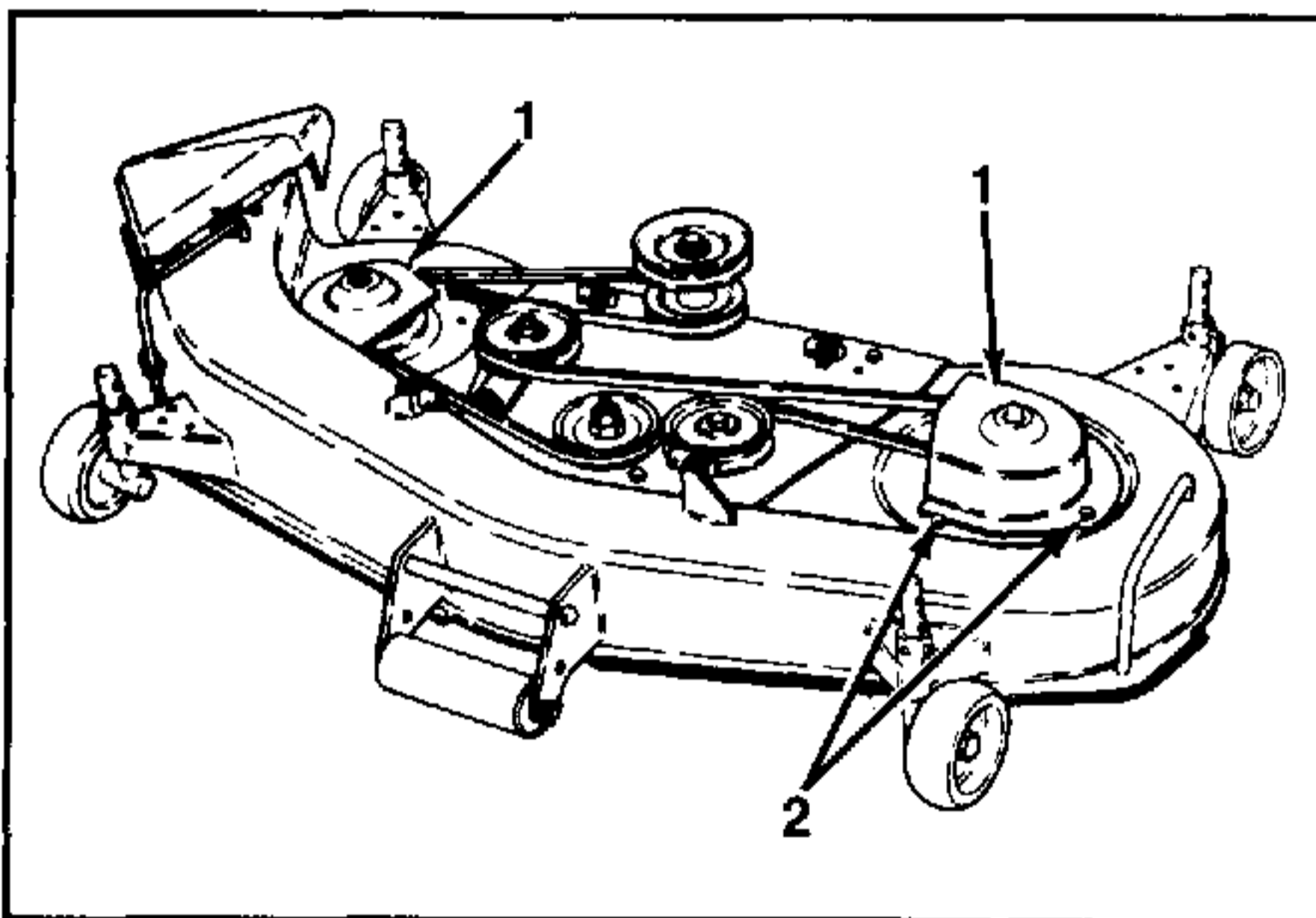

FIGURE 24.

1. Spindle Belt Cover
2. Nuts and Washers

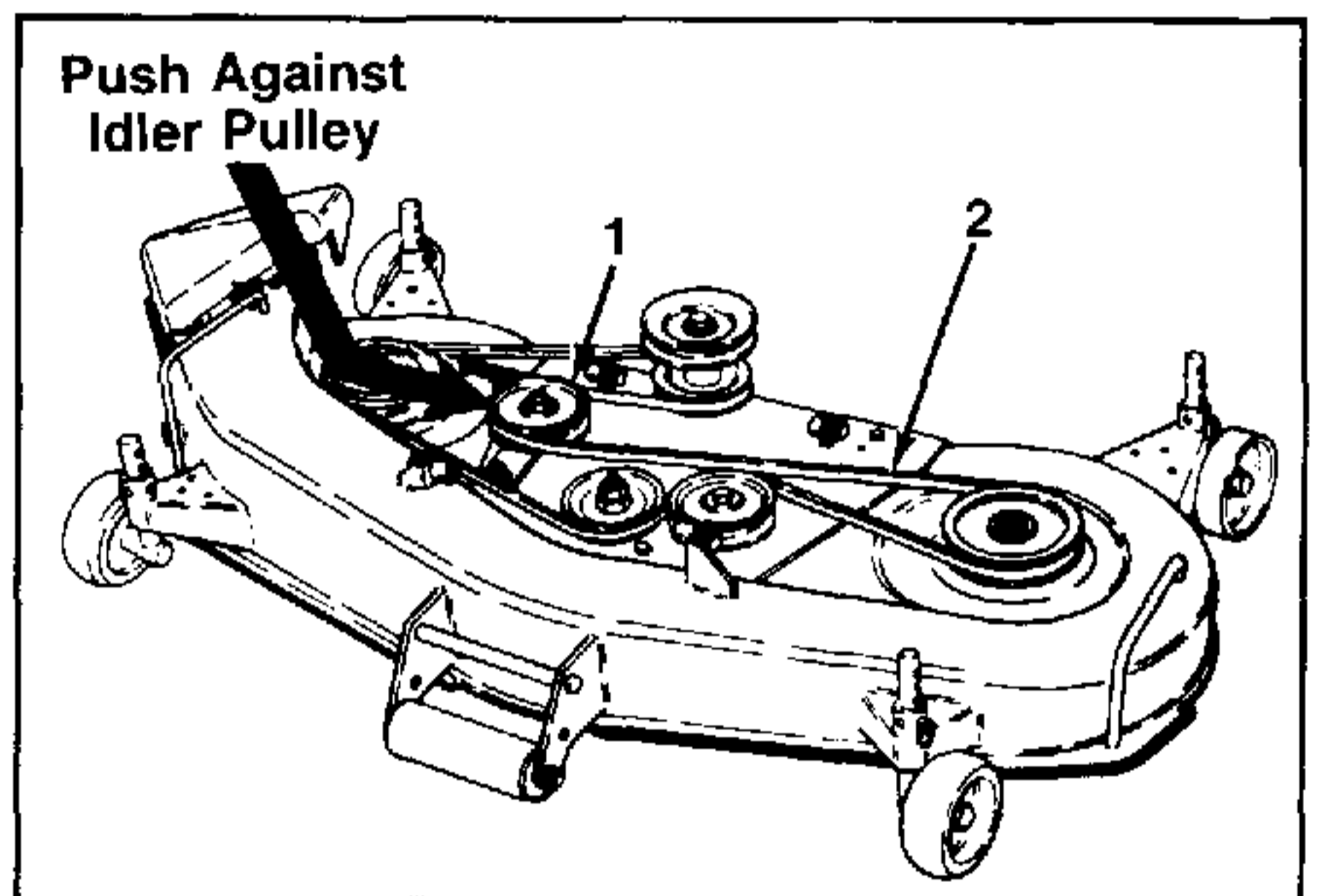

FIGURE 26.

1. Idler Pulley
2. Spindle Drive Belt

LUBRICATION GUIDE

The life of any machine depends upon the care it is given. Proper lubrication is a very important part of that care.

Be certain that all lubrication fittings are assembled in place, using the lubrication illustrations as a guide.

Always lubricate the deck thoroughly before taking it to the field. Use a pressure lubricating gun.

Be sure all fittings are free from dirt and paint so the lubricant is certain to enter the bearing.

Always force the lubricant through the full length of each bearing until it emerges at the end, carrying with it the worn lubricant and any dirt that may have entered the bearing.

Miscellaneous working parts not provided with lubrication fittings should be oiled daily with a good grade of lubricating oil.

Lubricant is cheap. Use plenty of it. Worn parts can be expensive to replace.

Keep your supply of lubricating oil and grease stored in clean containers, and covered to protect from dust and dirt.

Keep the lubricating gun nozzle clean and wipe dirt from grease fittings before lubricating.

The symbol in the illustration indicates the method of application and the hourly intervals to apply the lubricant.



Use a pressure lubricating gun and apply 251H EP grease (or equivalent No. 2 multipurpose lithium grease). Lubricate at hourly intervals indicated on symbol.

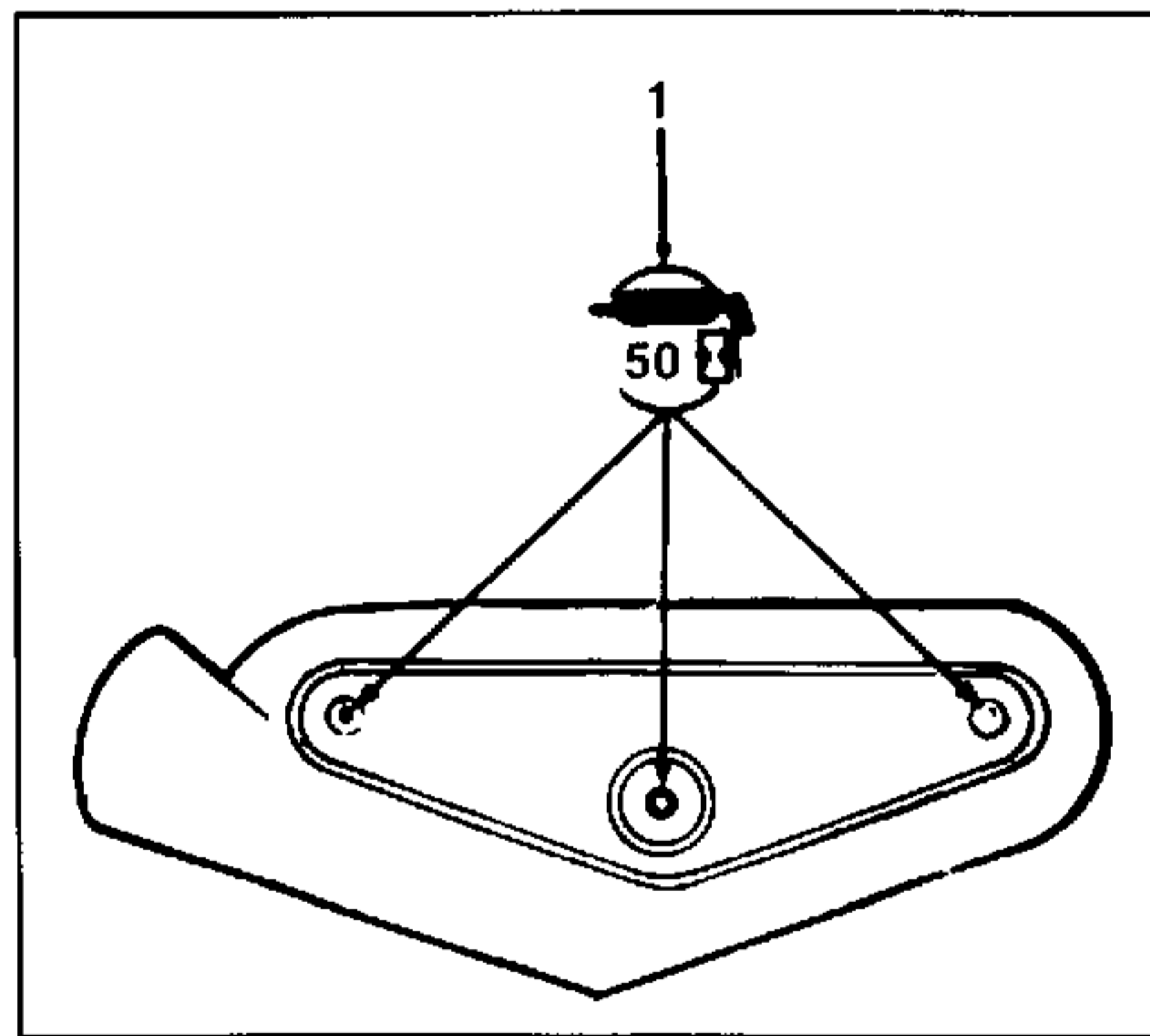

(46 Inch Deck)

1. Deck Spindles

—EVERY 50 HOURS OF OPERATION

Use 251H EP grease or equivalent No. 2 multipurpose lithium grease.

40" SNOW THROWER ATTACHMENT

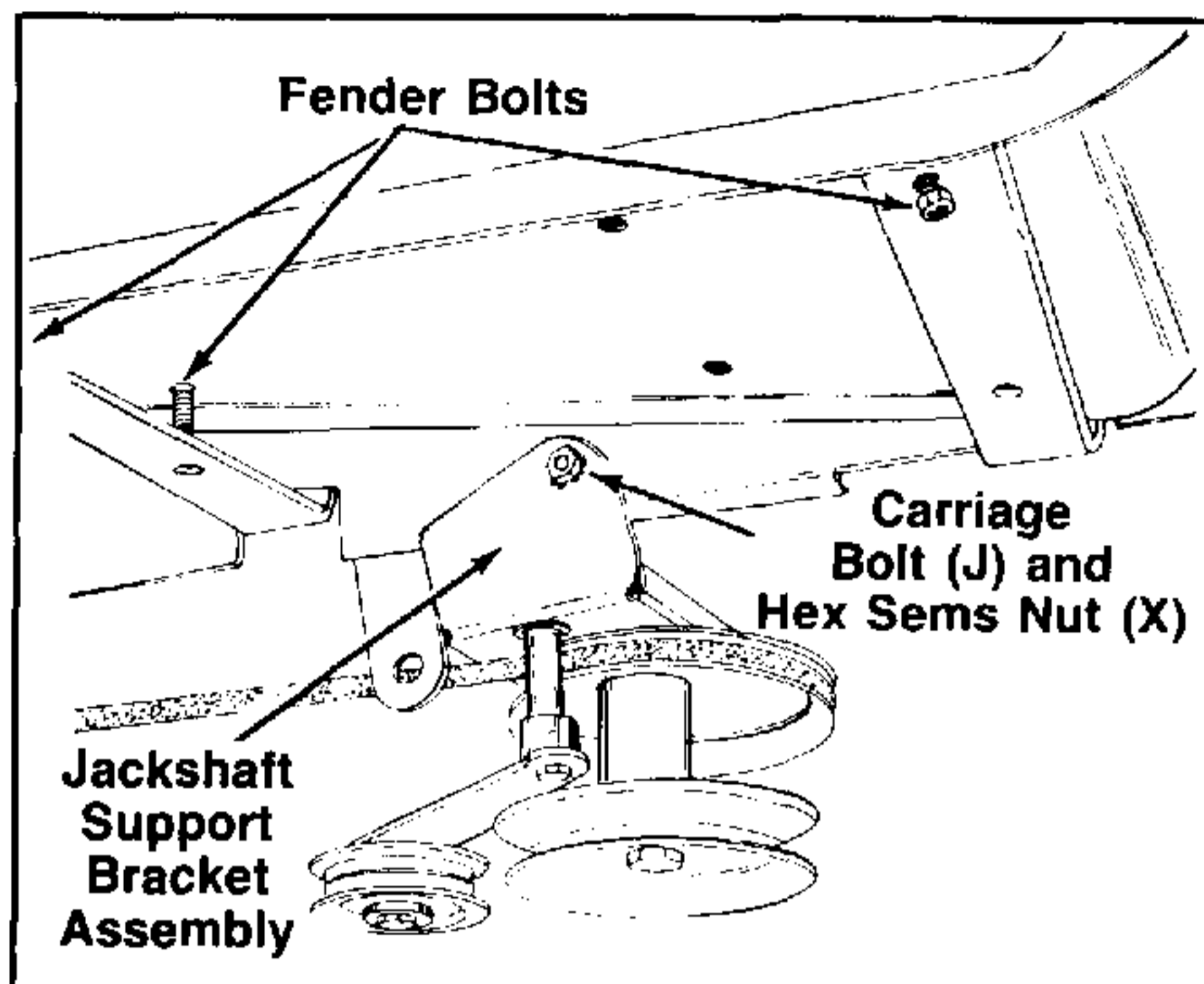

FIGURE 1.

1. Attach the jackshaft support bracket assembly as follows.

a. On the left hand side of tractor, loosen the three fender bolts and lift up on fender. See figure 1.

b. Place the jackshaft support bracket assembly in position over the square hole on side of frame. Secure with one carriage bolt (J) and hex sems nut (X). See figure 1.

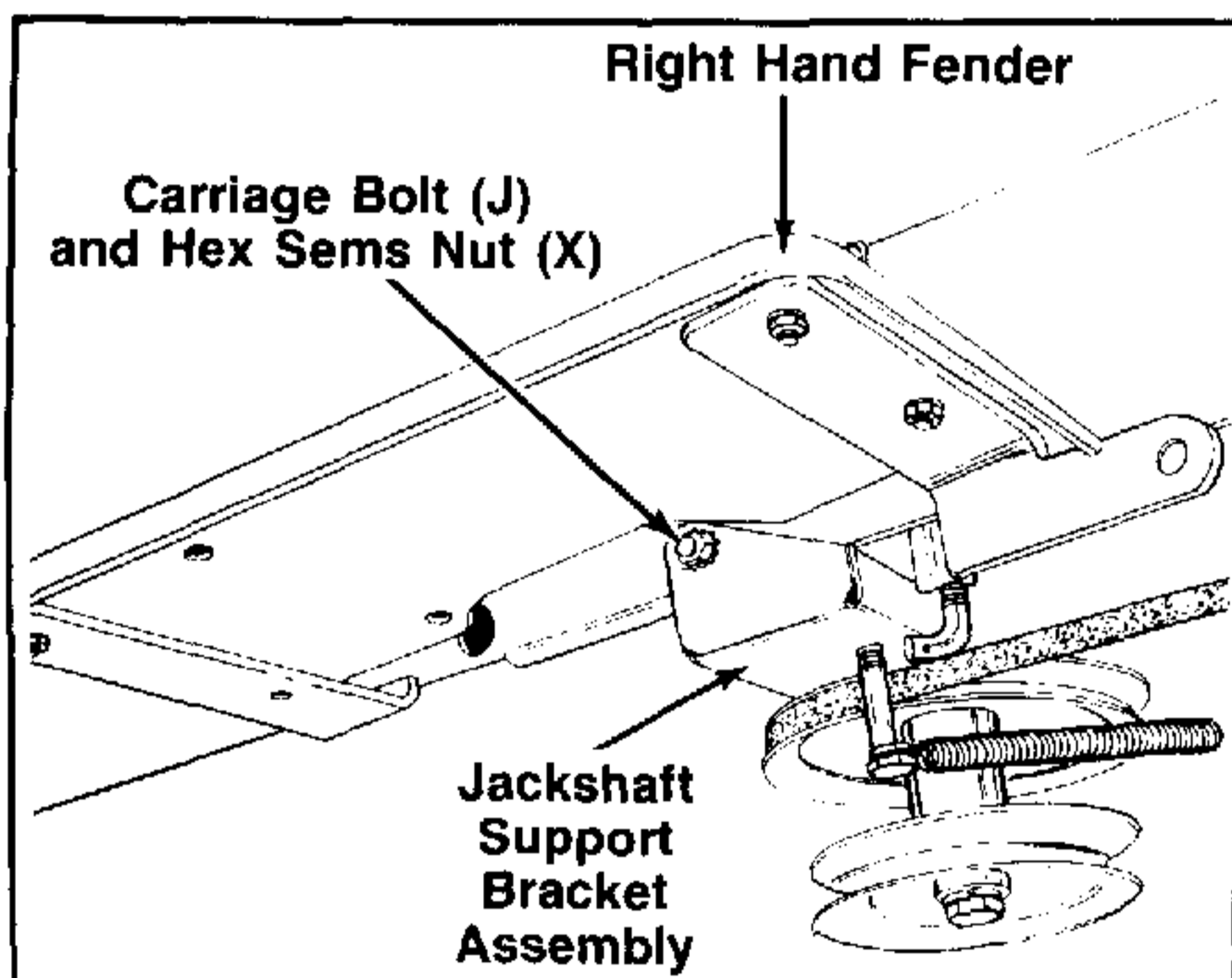

FIGURE 2.

c. Secure the jackshaft support bracket assembly on the right hand side of tractor, using carriage bolt (J) and hex sems nut (X). See figure 2.

NOTE

After jackshaft support bracket has been secured tightly, go back and tighten the three bolts and nuts on the left hand fender.

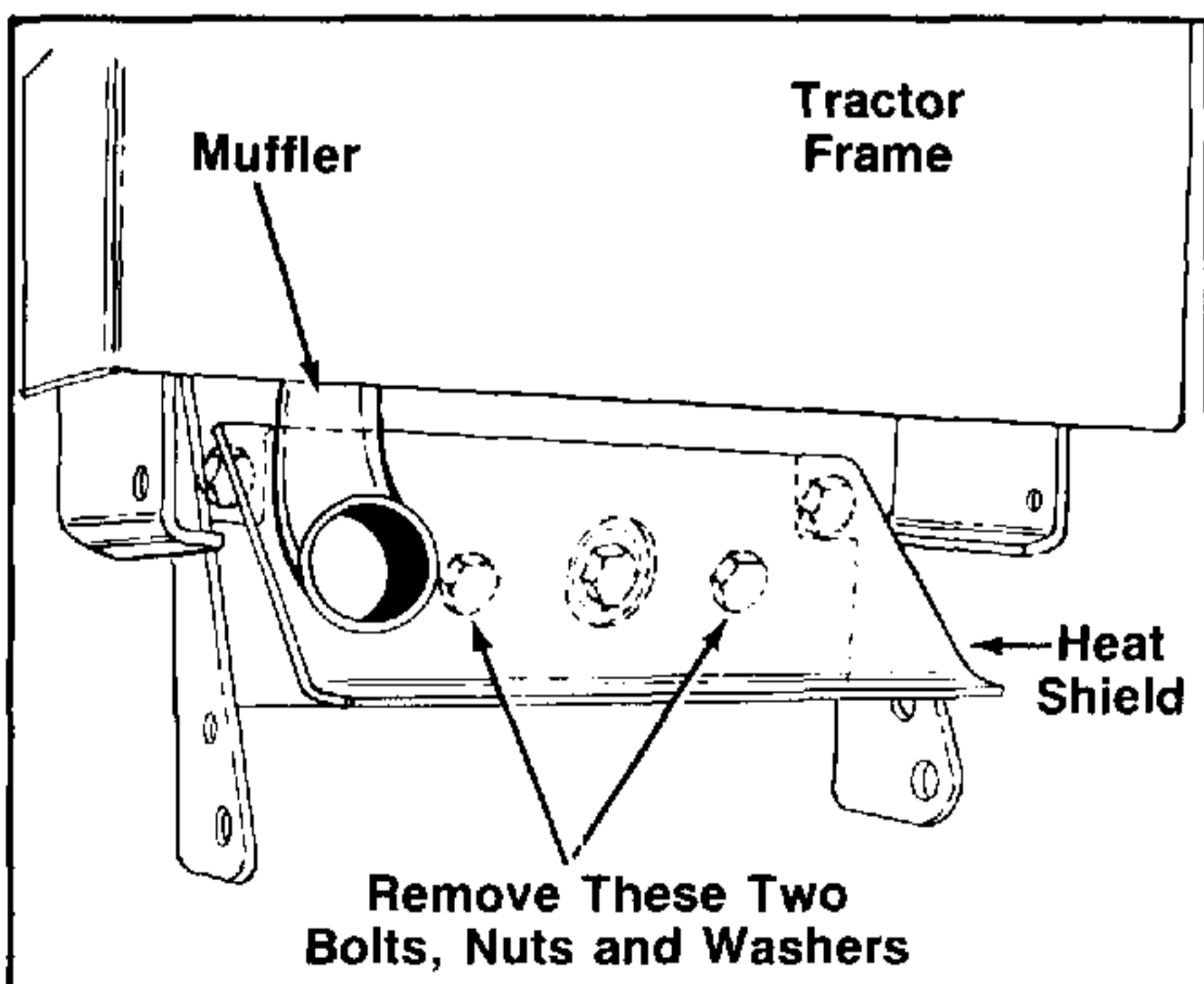

FIGURE 3.

2. Remove the heat shield on the tractor by removing two bolts, nuts and washers from heat shield and front of tractor frame as shown in figure 3.

IMPORTANT

Heat shield must be reassembled to the tractor when the snow thrower is removed, to protect your lawn when mowing. Keep heat shield and hardware in a safe place.

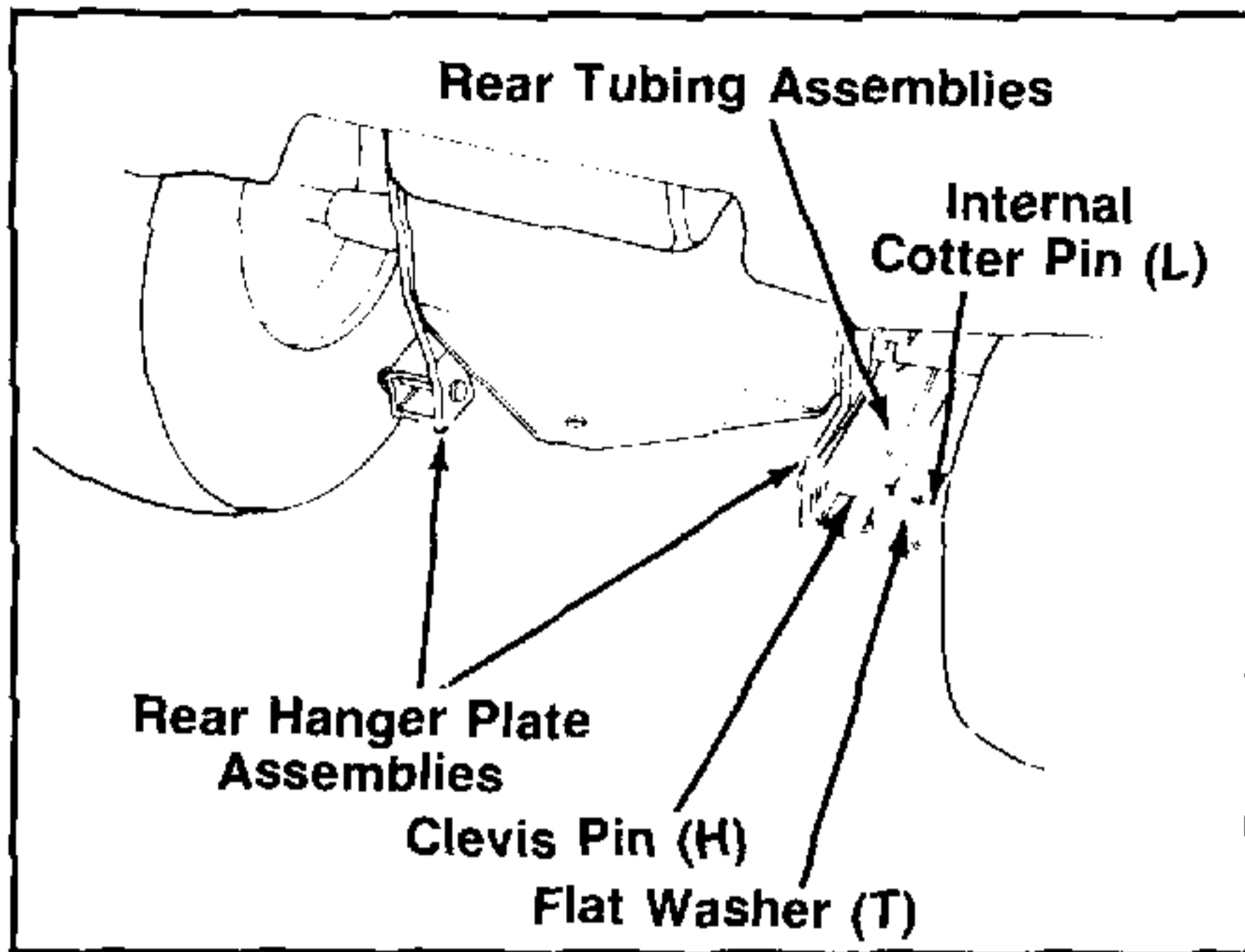

FIGURE 4.

3. Place the snow thrower attachment in front of tractor. Roll the tractor by hand into position over the tubing assemblies.
4. Route the top drive belt over the electric clutch on front of tractor and inside of the tractor idler. Refer to figure 7.
5. Attach the rear tubing assemblies to the rear hanger plate assemblies. Secure with clevis pins (H), flat washers (T) and internal cotter pins (L). See figure 4.

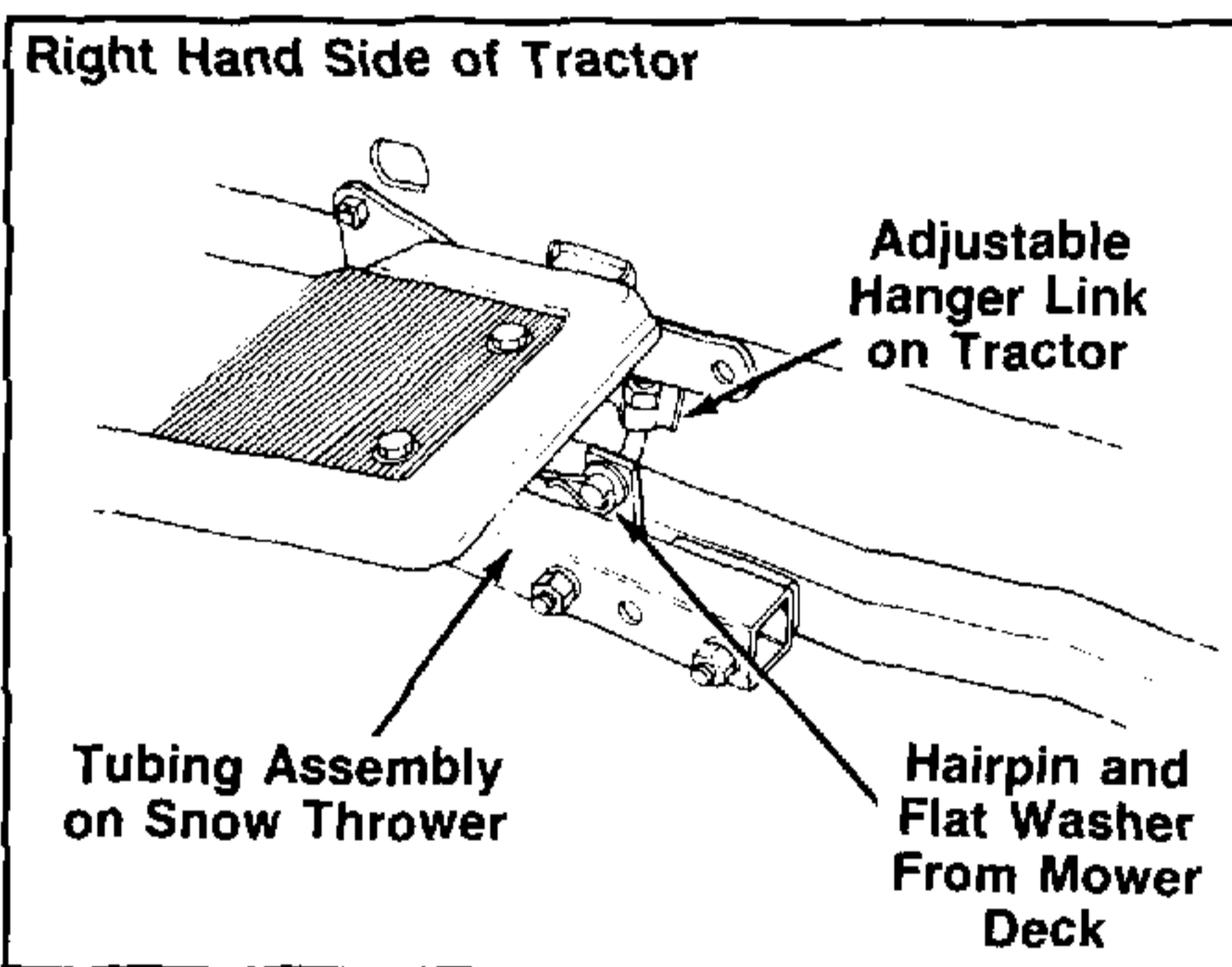

FIGURE 5.

6. Lower the lift control lever on tractor to lowest setting.
7. Secure the hanger bracket on left hand side of tractor with clevis pin, flat washer and hairpin cotter (which came with the mowing deck). See figure 6.
8. Secure the adjustable hanger link on right hand side of tractor with flat washer and hairpin cotter (which came with the mowing deck). See figures 5 and 6.

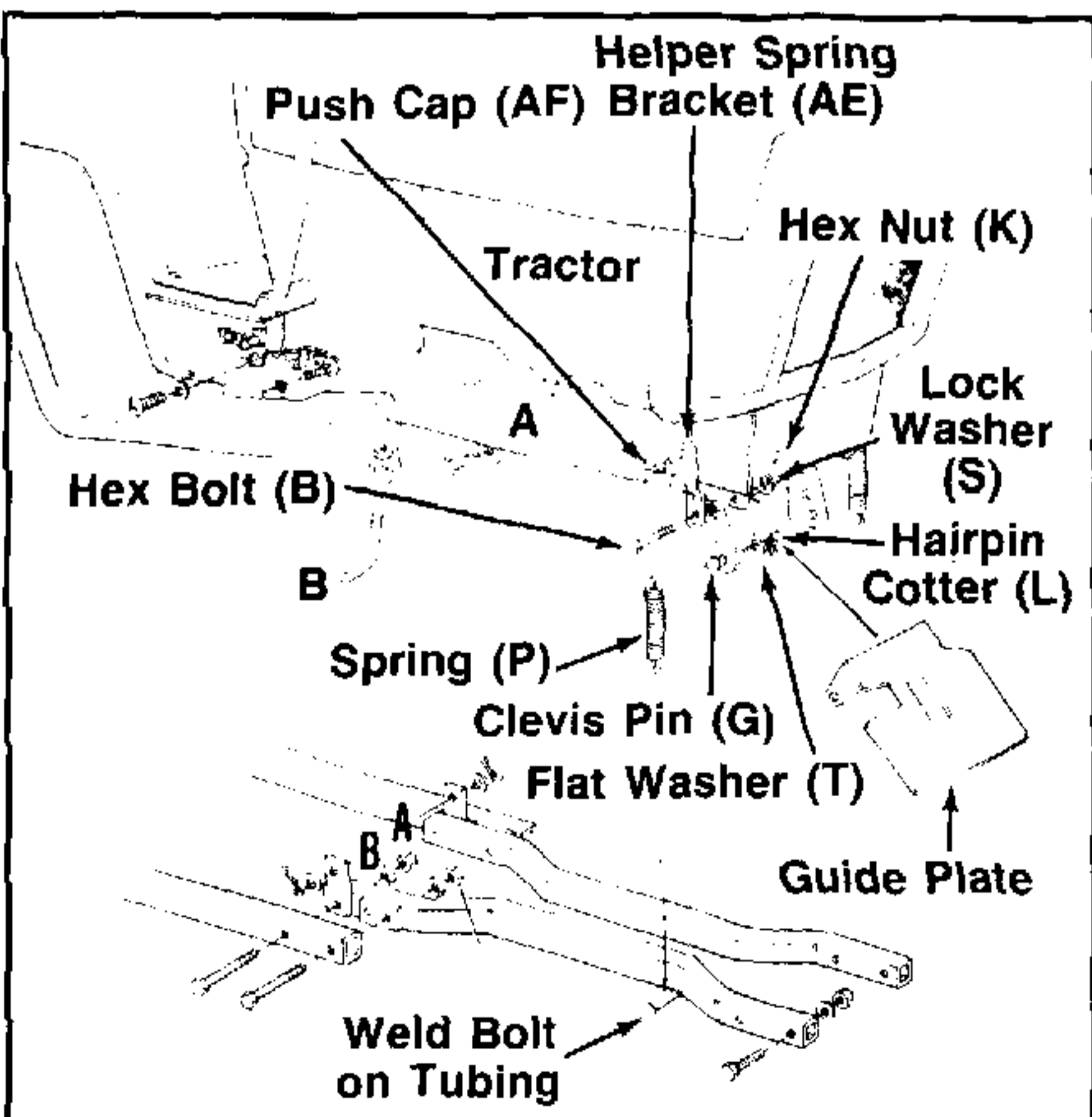

FIGURE 6.

9. Assemble the helper spring brackets (AE) as follows.
 - a. Place push cap on weld bolt on helper spring bracket and tap on with hammer.
 - b. Place hex bolt (B) through hole in helper spring bracket as shown in figure 6. Place spacer (AD) on hex bolt.
 - c. Secure to tractor with lock washer (S) and hex nut (K). Tighten securely.
 - d. Assemble the other bracket in the same manner.
10. Hook one end of extension spring (P) over weld bolts on helper spring brackets. Hook the other end over weld bolts on tubing assemblies. See figure 6.
11. Assemble the guide plate to the front of tractor, using clevis pins (G), flat washers (T) and hairpin cottes (L). See figure 6.

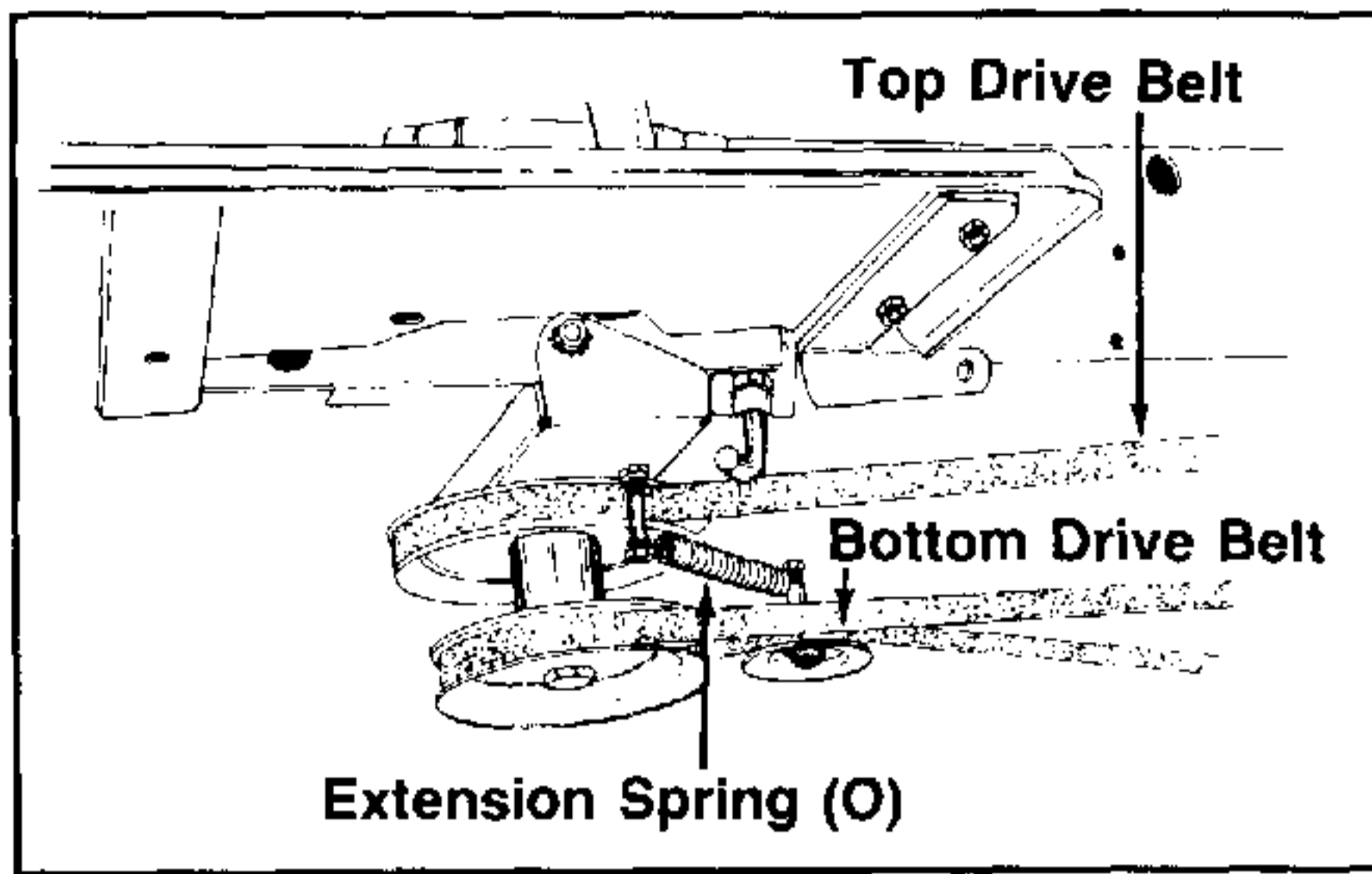

FIGURE 7.

12. Now tighten the four hex bolts which hold the rear hanger plate assemblies to rear of tractor.
13. Attach one end of extension spring (O) to the hex bolt on jackshaft support bracket and the other end to the hex bolt which secures the idler pulley to the bracket. See figure 7.

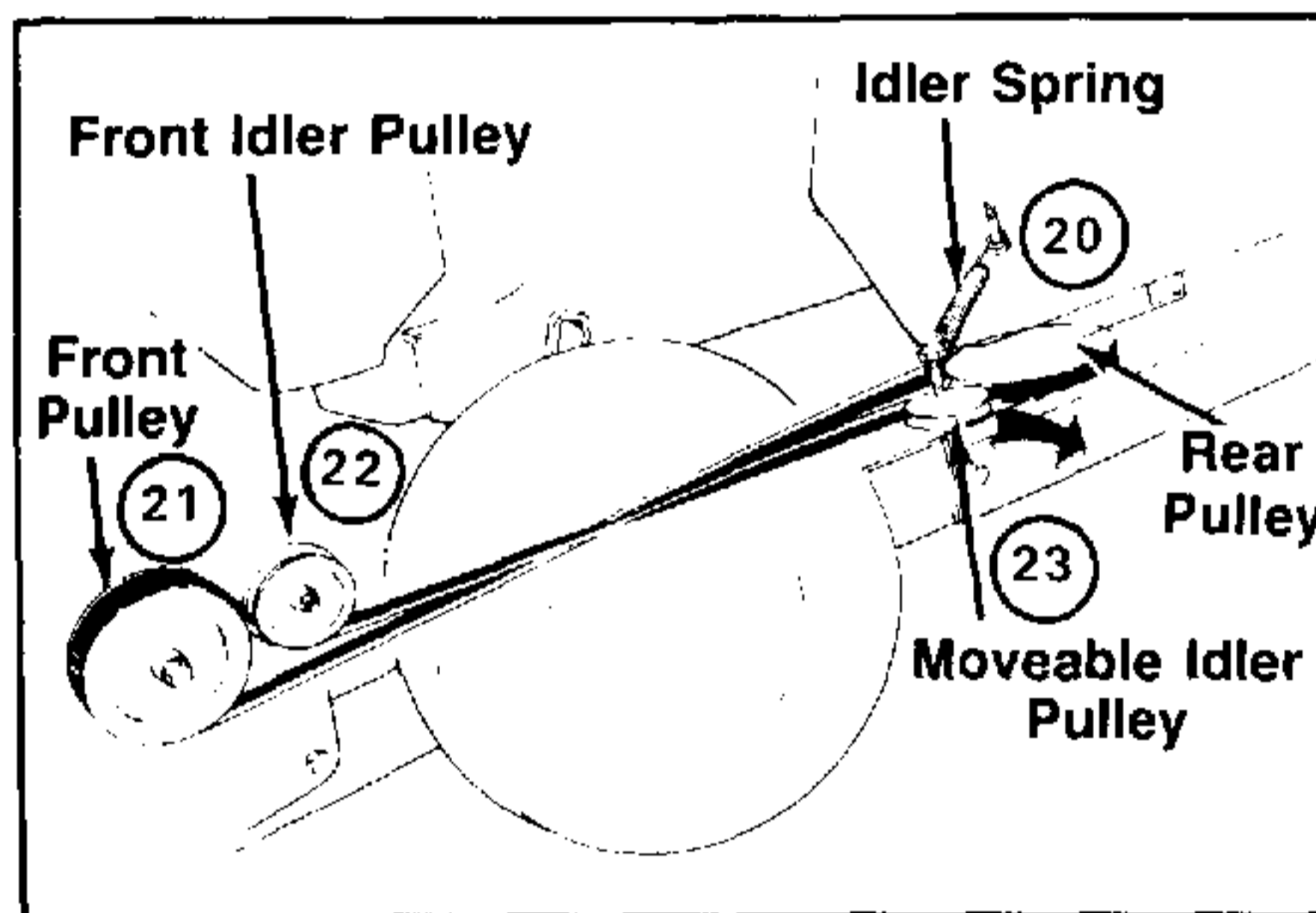

FIGURE 8.

14. Remove the idler spring from the right hand side of tractor. Place new belt around rear pulley. See figure 8.
15. Remove the front idler pulley. Twist belt 90° as shown below. Feed belt onto front pulley.

NOTE

← Belt must be assembled as shown in figure 8. Top of belt goes over rear pulley and then twist belt to the right. The bottom of the belt goes to the left. If the belt is assembled incorrectly, the auger will run in reverse.

16. Reassemble front idler pulley, placing belt under front idler pulley.
17. Pull moveable idler pulley to the outside position and place belt in pulley. Reassemble idler spring from the right hand side of tractor. See figure 8.

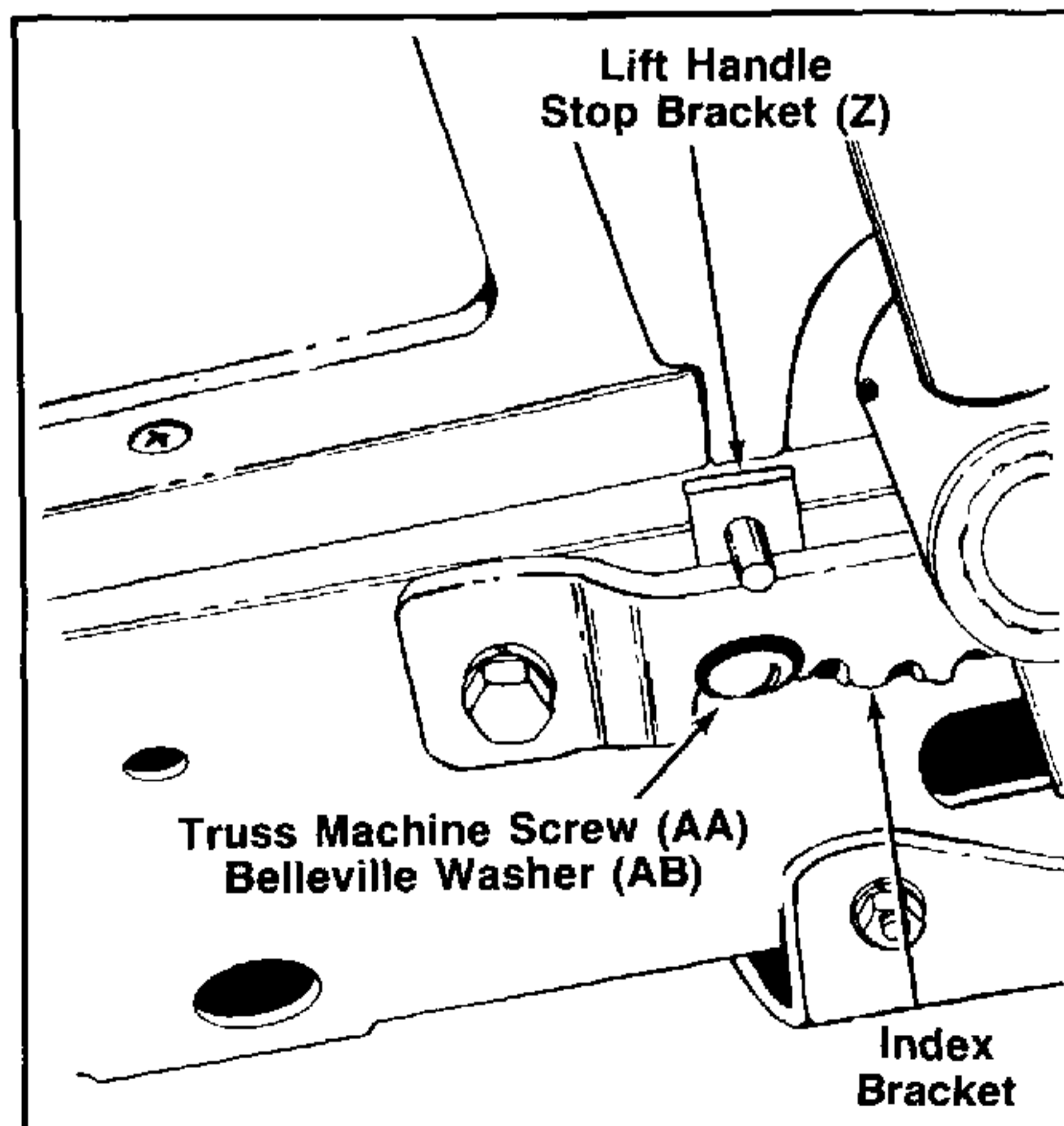

FIGURE 9.

18. Units with Serial Numbers 109,000 and below: Attach the lift handle stop bracket (Z) to the index bracket on the tractor as shown in figure 9, using belleville washer (AB) (cupped side against the index bracket) and truss machine screw (AA).

NOTE

← Loosen the hex bolts which secure the index bracket if necessary in order to slide the lift handle stop bracket behind it. Be certain to retighten the hex bolts.

19. Adjust skid shoes to desired position and tighten hex nuts. See adjustment section.
20. Check tire pressure. It may be necessary to put more air into the front tires due to the weight of the snow thrower.

ADJUSTMENTS



When making any adjustments, turn tractor engine off.

SKID SHOE ADJUSTMENT

The skid shoes are mounted on each side of spiral housing. These regulate the distance the shave plate is raised above the plowing surface. When removing snow from a gravel driveway or an uneven surface, it is advisable to keep shave plate as high above the surface as possible to prevent possible damage to spiral.

On blacktop or concrete surface, keep shave plate as close to the surface as possible. Skid shoes can be adjusted to that shave plate will rest directly on the surface. Turning skid shoes around or inverting them will allow even wear on skid shoes.

Raise snow thrower off the ground and place a block at each end of shave plate. Loosen 4 hex nuts securing skid shoes to spiral housing (2 nuts on each side). Move skid shoes up or down to desired position and tighten nuts securely. Adjust both skid shoes to the same height to keep spiral level. See figure 10.

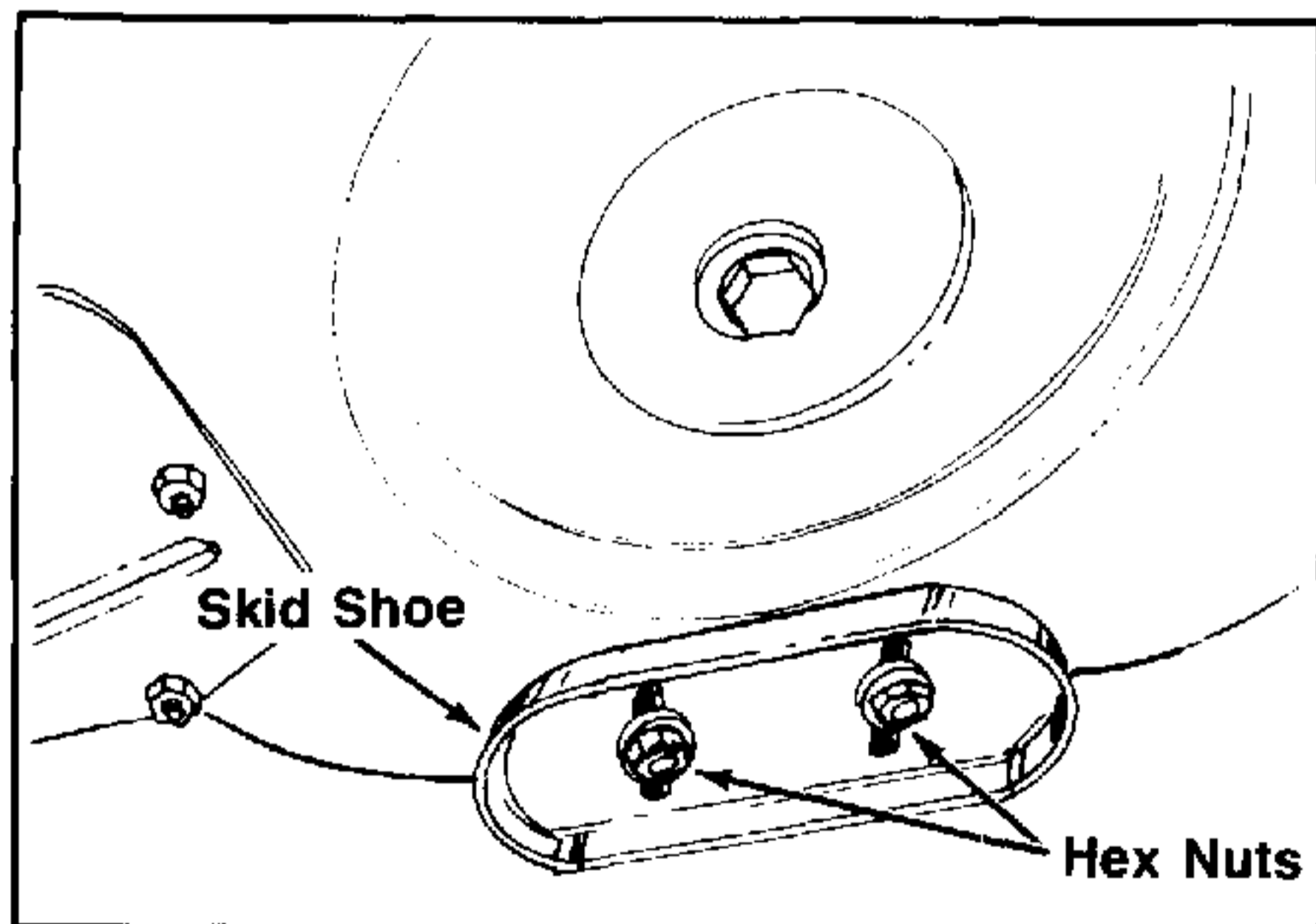

FIGURE 10.

CHUTE DEFLECTOR ADJUSTMENT

The upper chute deflector mounting on the top of the chute determines the distance snow is thrown. Moving top of deflector down decreases distance of throw and raising deflector increases distance of throw. Operator must get off tractor to make this adjustment. Disengage spirals and turn engine off before making this adjustment.

To adjust, loosen hand knob on the side of chute deflector and pivot to desired position. Retighten hand knob. See figure 11.

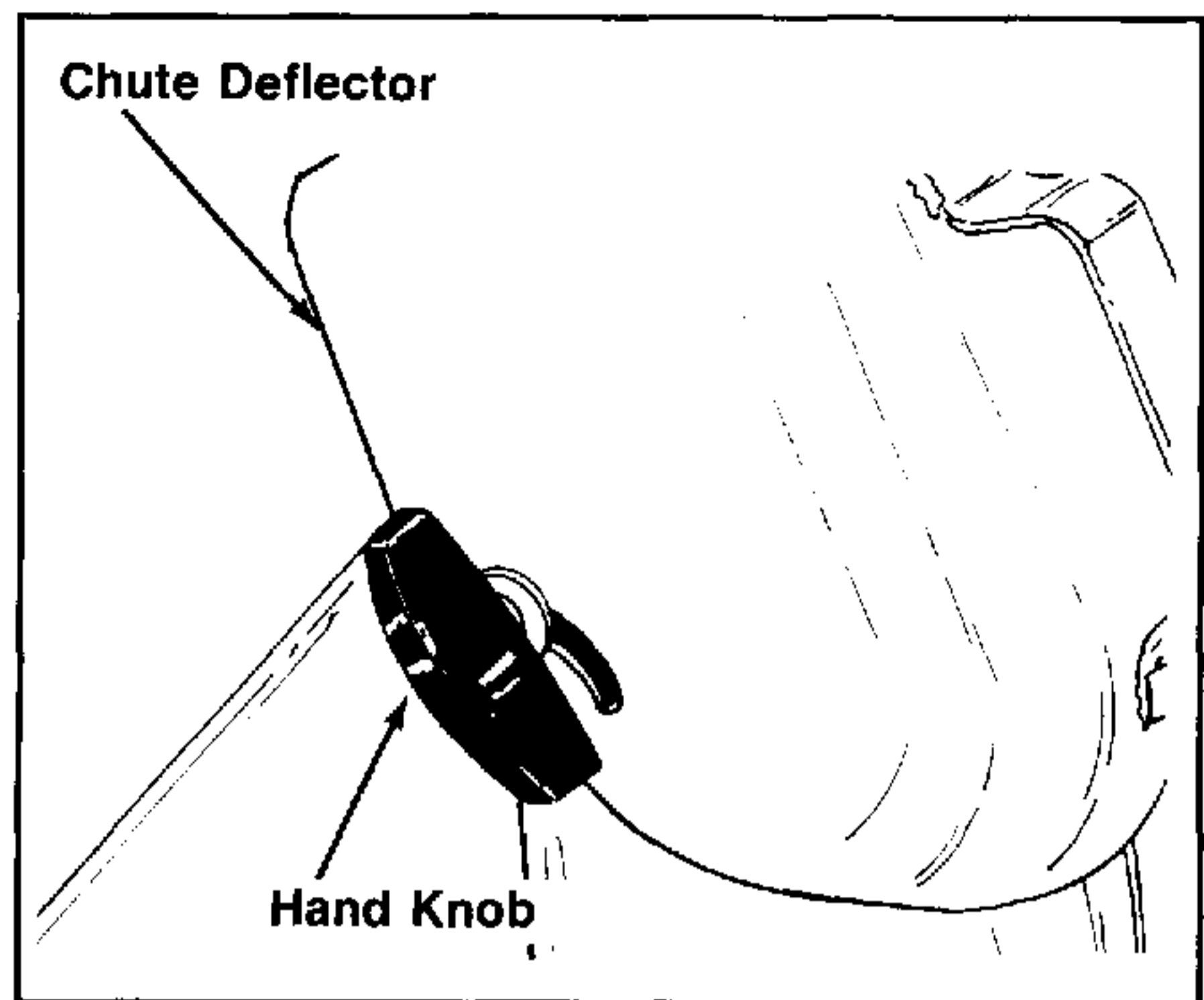

FIGURE 11.

SPIRAL DRIVE CHAIN ADJUSTMENT

Excessive slack in spiral drive chain due to normal chain stretch can be removed by adjusting spiral housing nuts.

To adjust spiral chain:

1. Disengage snow thrower and loosen the adjusting nut 2 or 3 complete turns. See figure 12.
2. Move adjusting nut down as needed.

NOTE

Do not overtighten chain. A correctly adjusted chain will have a slight amount of slack. An overtightened chain will result in early failure of chain.

3. Tighten adjusting nut to secure chain adjustment. Check chain clearance. It must clear chain guard assembly. Test chain and repeat adjustment if necessary until all excess slack is removed.

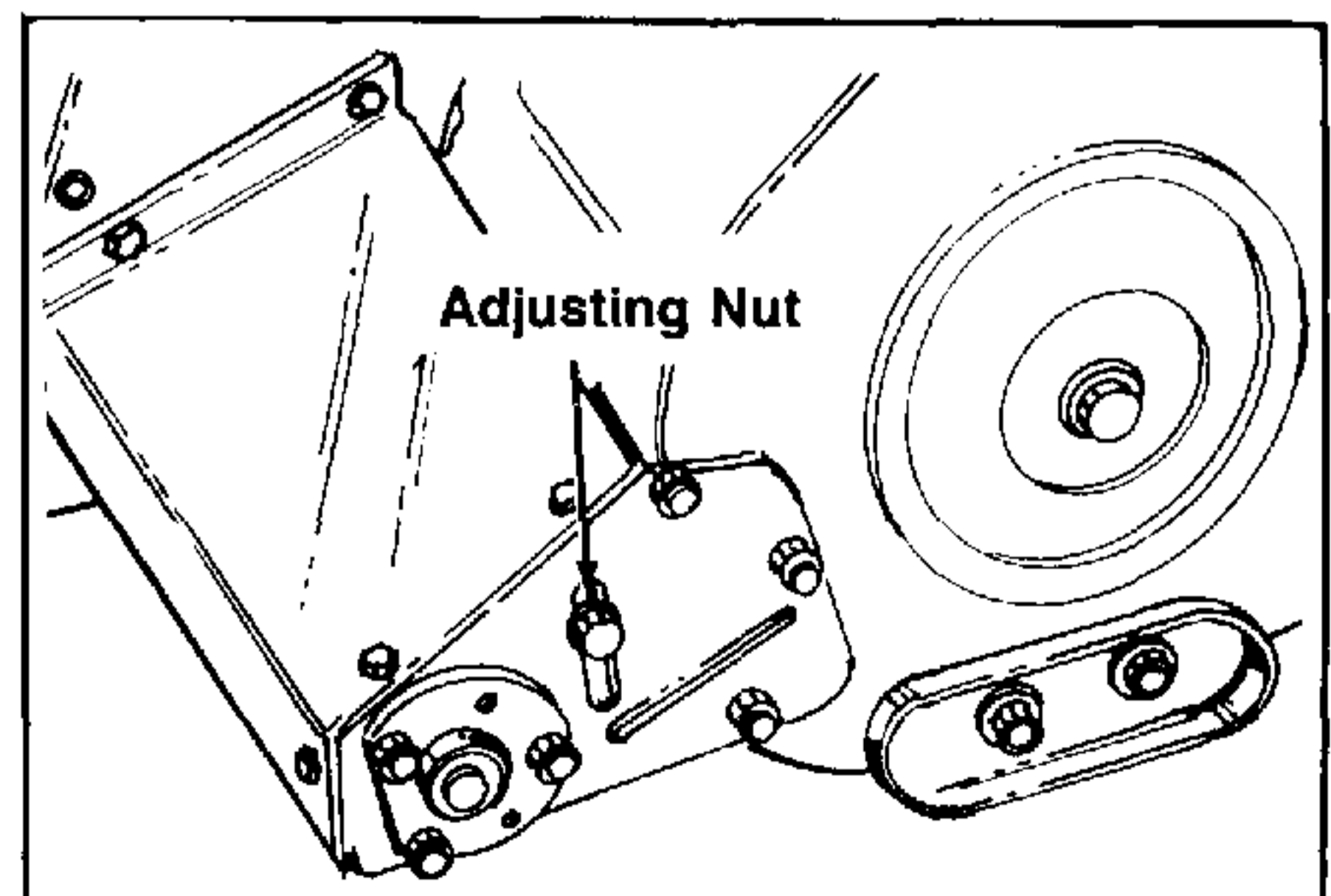

FIGURE 12.

LUBRICATION

1. Spiral drive chain: Lubricate chain every 40 hours with No. 30 oil. It is important that oil reaches inside each roller. Wipe off excess oil from chain. See figure 13.

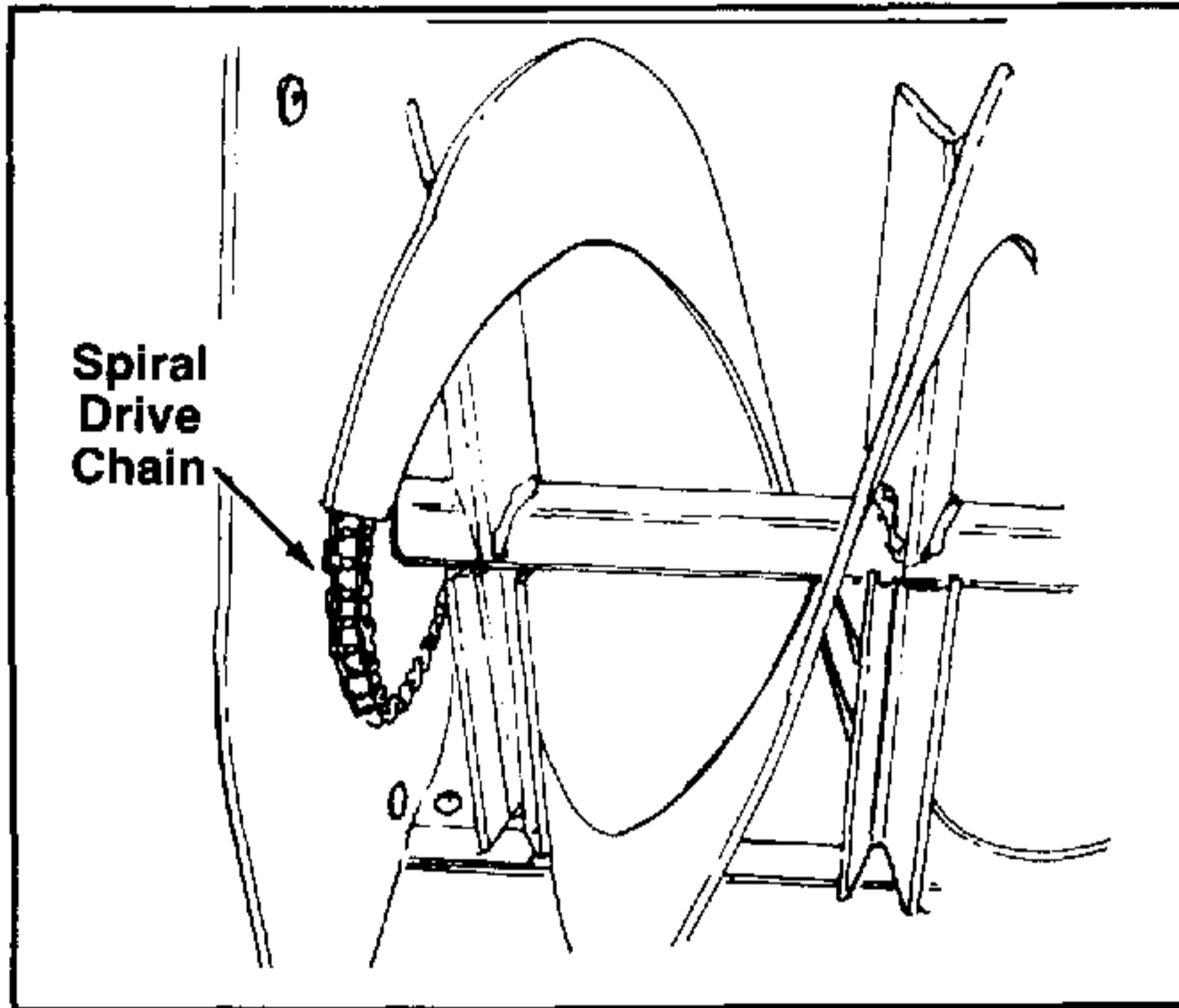

FIGURE 13.

2. Pivot and friction points: To maintain smooth and free operation, apply a few drops of No. 30 oil as required to all pivot and friction points.

The spiral and idler pulley bearings are self-lubricating. However, periodic lubrication with No. 30 oil will lengthen service life.

MAINTENANCE

SHAVE PLATE AND SKID SHOES

The shave plate and skid shoes on the bottom of the snow thrower are subject to wear. They should be checked periodically and replaced when necessary. Skid shoes and shave plate are reversible for longer life. The skid shoes may also be inverted to extend their life even further.

Replace shave plate and skid shoes before wear is excessive. Failure to do so will result in damage to the spiral housing.

Model 350

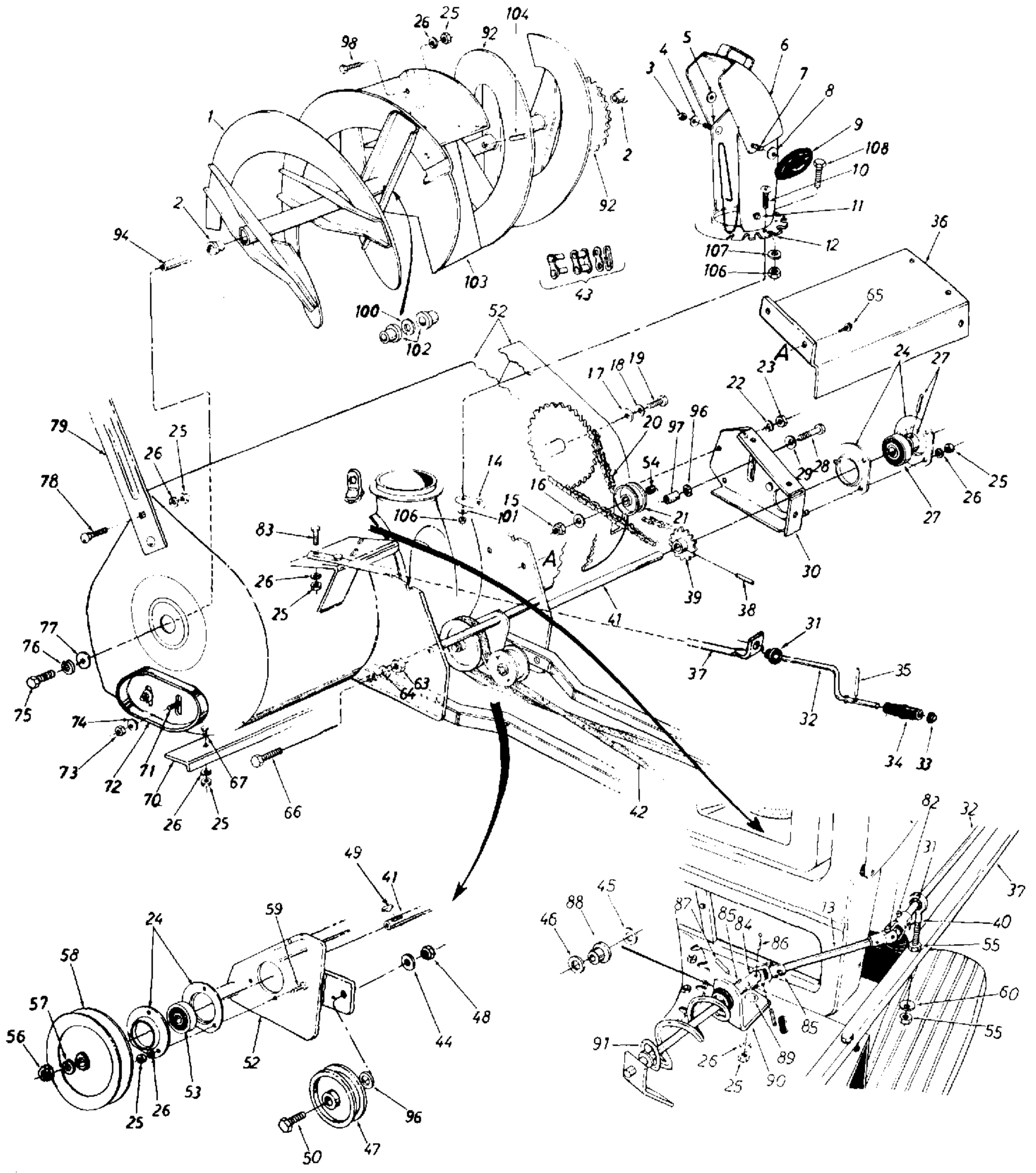

Model 350

40" SNOW THROWER ATTACHMENT

Ref. No.	Description	Ref. No.	Description
1	Spiral Ass'y. (L.H.)	50	Hex Bolt 3/8-16 x 1.50" Lg.*
2	Flange Bearing	52	Spiral Housing Ass'y.
3	Hex Cent. L.-Nut 5/16-18 Thd.	53	Self-Aligning Bearing
4	Belleville Wash. 3/8" I.D.	54	Sleeve Bearing .50" I.D.
5	Flat Washer 3/8" I.D.	55	Hex Nut 5/16-18 Thd.*
6	Top Chute Ass'y.	56	Hex Nut 3/4-10 Thd.
7	Carriage Bolt 5/16-18 x .62" Lg.*	57	L-Wash. 3/4" I.D.
8	Belleville Wash. 3/8" I.D.	58	"V"-Pulley .750" I.D. x 6.00" O.D.
9	Hand Knob	59	Hex Sems Bolt 5/16-18 x .75" Lg.*
10	Truss Mach. Scr. 1/4-20 x .75" Lg.	60	Bell-Wash. .345" I.D. x .88" O.D.
11	Push Cap .188" Dia. Rod	63	Hex L-Nut 1/2-20 Thd.
12	Chute Ass'y.	64	L-Wash. 1/2" I.D.*
13	Chute Crank Extension Rod	65	Hex Wash. Hd. Tap Scr. 1/4-20 x .50" Lg.
14	Chute Flange Keeper	66	Hex Bolt 1/2-20 x 1.25" Lg.*
15	L-Nut 3/8-16 Thd.	67	Carriage Bolt 5/16-18 x .62"*
16	FI-Wash.	70	Shave Plate
17	FI-Wash.	71	Carriage Bolt 3/8-16 x .75" Lg.*
18	Belleville Wash.	72	Skid Shoe
19	Hex Bolt 1/2-13 x 1.00" Lg.*	73	Hex Nut 3/8-16 Thd.*
20	#420 Chain 1/2" Pitch x 77 Links	74	Belleville Wash. 3/8" I.D.
21	Plastic Idler 2.00" O.D.	75	Hex Bolt 1/2-13 x 1.00" Lg.*
22	L-Wash. 1/4" I.D.*	76	Belleville Wash. 1/2" I.D.
23	Hex Nut 1/4-20 Thd.*	77	FI-Wash.
24	Bearing Housing	78	Carriage Bolt 5/16-18 x .62" Lg.*
25	Hex Nut 5/16-18 Thd.*	79	Drift Cutter
26	L.-Wash. 5/16" I.D.*	82	Cotter Pin
27	Self-Aligning Bearing	83	Hex Bolt 5/16-18 x 1.50" Lg.*
28	Hex Bolt 3/8-16 x 1.75" Lg.*	84	Joint Block
29	Belleville Wash. 3/8" I.D.	85	Joint Bracket Ass'y.
30	Chain Guard Ass'y.	86	Oval Head Rivet
31	Nylon Bushing	87	Spring Pin Roll 1/8" Dia. x .75" Lg.*
32	Chute Crank .375 Dia. x 33" Lg.	88	Nylon Bushing
33	Push Nut 3/8" Rod	89	Carriage Bolt 5/16-18 x .62
34	Knob (Black)	90	Chute Crank Bracket
35	Roll Pin	91	Chute Crank Ass'y.
36	Drive Shaft Cover	92	Spiral Ass'y. (R.H.)
37	Crank Support Tubing	94	Spiral Axle
38	Spring Pin Spiral 5/16" Dia. x 1.75" Lg.	96	Flat Washer
39	14 Teeth Sprocket Ass'y.	97	Idler Spacer
40	Eyebolt 5/16-18 x 3.0" Lg.	98	Carriage Bolt 5/16-18 x .75" Lg.
41	Drive Shaft	99	FI-Wash. 1.0" I.D. x 1.75" O.D.
42	"V"-Belt 1/2" x 90" Lg. Kevlar	100	FI-Wash. 1.03" I.D. x 1.62" O.D.
43	Master Link for #420 Chain	101	Bell-Wash. 1/4" I.D.
44	L-Wash. 3/8" I.D.*	102	Plastic Bushing
45	FI-Wash. .385 I.D. x .62" O.D.	103	Rotor Paddle Ass'y.
46	FI-Wash. .390 I.D. x 1.50" O.D.	104	Spring Pin Spir. 5/16" Dia. x 1.75" Lg.
47	FI-Idler with Flanges	106	Hex Nut 1/4-20 Thd.
48	Hex Jam L.-Nut 3/8-26 Thd.	107	FI-Wash. 1/4" I.D.
49	Hi-Pro Key	108	Truss Mach. Scr. 1/4-20 x .5"

Model 350

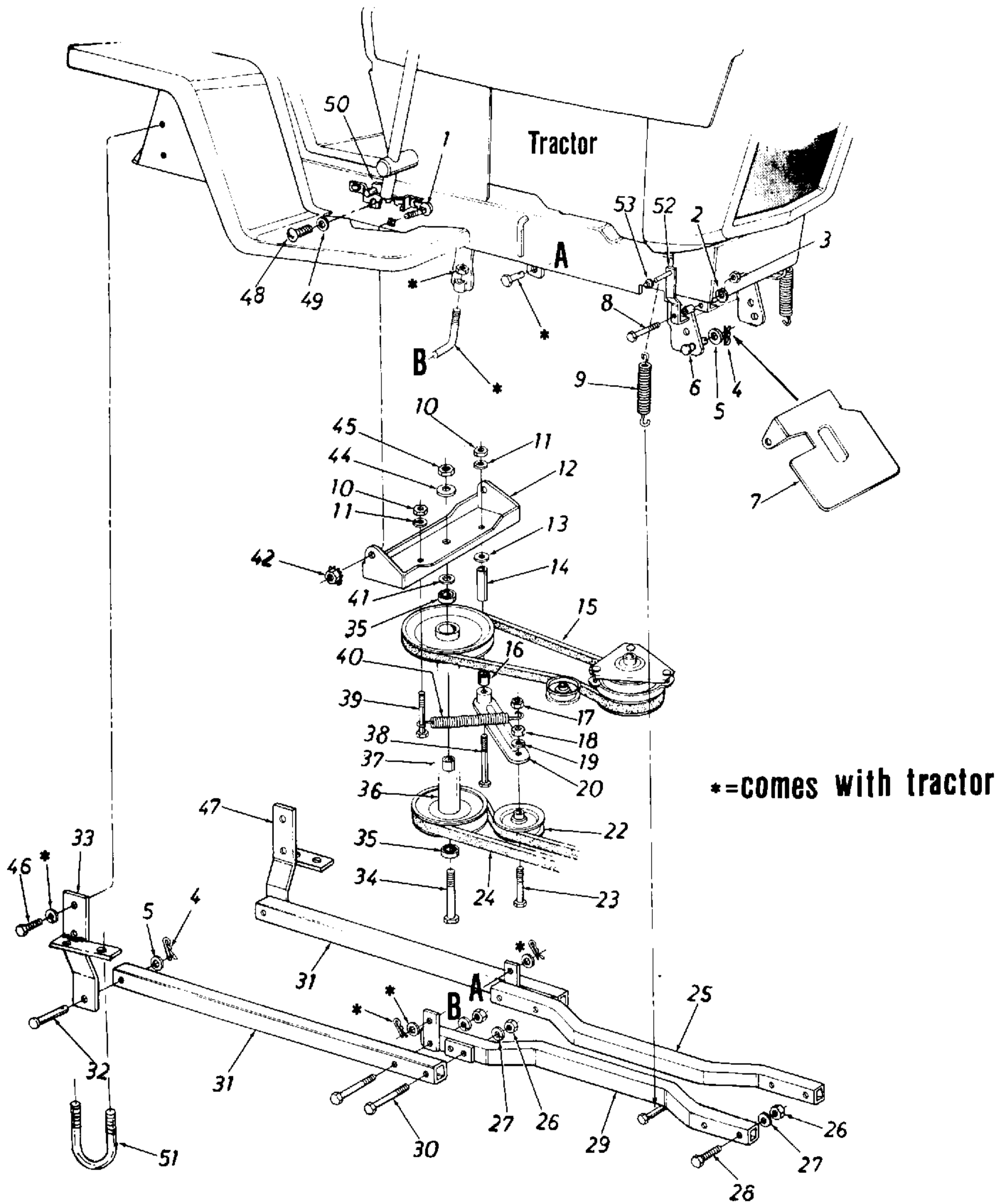

Model 350

40" SNOW THROWER

Ref. No.	Description	Ref. No.	Description
1	Carriage Bolt 5/16-18 x .62" Lg.*	28	Hex Bolt 1/2-13 x 2.75" Lg.*
2	L-Wash. 1/4" I.D.*	29	Front Support Tubing Ass'y.—R.H.
3	Hex Nut 1/4-28 Thd.	30	Hex Bolt 1/2-13 x 4" Lg.*
4	Internal Cotter Pin 1/2" Dia.	31	Sq. Tubing 1 1/2" x 38.0" Lg.
5	Fl-Wash. .510" I.D. x 1.0" O.D.	32	Clevis Pin .50" Dia. x 2.19" Lg.
6	Lift Bracket Pin	33	Hanger Plate Ass'y.—R.H.
7	Guide Bracket .510" Dia.	34	Hex Bolt 5/16-18 x 4.50" Lg.*
8	Hex Bolt 1/4-28 x 1.25" Lg.	35	Ball Brg. .62" I.D. x 1.38" O.D. x .44"
9	Extension Spring 1.0" O.D. x 4.17" Lg.	36	Double Groove Pulley
10	Hex Jam Nut 3/8-16 Thd.*	37	Pulley Spacer
11	Bell-Wash. .400" I.D. x .88" O.D.	38	Hex Bolt 3/8-16 x 3.25" Lg.*
12	Jack Shaft Support Bracket	39	Hex Bolt 3/8-16 x 2.25" Lg.*
13	Bell-Wash. .400" I.D. x .88" O.D.	40	Extension Spring .54" O.D. x 5.25" Lg.
14	Spacer .37" I.D. x .562" O.D. x 1.50" Lg.	41	Fl-Wash. 5/8" I.D. x 1.0" O.D. x .063 Thk.
15	"V"-Belt 1/2 x 47.0" "A" Polyester	42	Hex Nut 5/16-18" Thd.*
16	Spacer .377" I.D. x .600" O.D. x .830" Lg.	44	Bell-Wash. .630" I.D. x 1.25" O.D.
17	Hex Cent. L-Nut 3/8-16 Thd.	45	Hex Jam Nut 5/16-18 Thd.
18	Hex Jam Nut 3/8-16 Thd.	46	Hex Bolt 3/8-16 x 1.25" Lg.
19	L-Wash. 3/8" I.D.*	47	Hanger Plate Ass'y.—L.H.
20	Idler Arm Ass'y.	48	Truss Mach. Scr. 1/4-20 x .75" Lg.
22	Idler Pulley	49	Bell-Wash. .265" I.D. x .75" O.D.
23	Hex Bolt 3/8-16 x 2.25" Lg.*	50	Lift Handle Stop Brkt.
24	"V"-Belt 1/2" x 90" "A" Polyester	51	U-Bolt 5/16-18 x 2.75" Lg.
25	Front Support Tubing Ass'y.—LH.	52	Helper Spring Brkt.
26	Hex Nut 1/2-13 Thd.*	53	Push Cap
27	L-Wash. 1/2" I.D.*		

Section 4

P.T.O. TROUBLE SHOOTING AND VX SERIES CLUTCHES

Contents

P T O —For Models 805, 1105, 1110, 1605, 1610, 1215, 1220, 1615 and 1620	4 2 thru 4 3
Electrical Diagram, L T Serial No 107,999 and Below	4-4
Electrical Diagram, L T Serial No 108,000 and Above, Serial No 114,000 and Above	4-5
VX Series Clutches for Lawn Tractors 805, 1105, 1110, 1605, 1610, 1215, 1220, 1405, 1415, 1420, 1615, 1620, 1715 and 1720	4 6 thru 4 7
Mechanical P T O —For Models 1015, 1020, 1315 and 1320	4 8 thru 4 9

P.T.O. Trouble Shooting Procedures

805, 1105, 1110, 1605, 1610, 1215, 1220, 1615 and 1620

1. P.T.O. Does not engage.

NOTE: THIS TEST SHOULD BE PERFORMED WITH THE ENGINE OFF.

- A. With key switch on check for current at terminal five (5) of the P.T.O. switch. Red wire. If okay go to step B.
- B. Move P.T.O. switch to start position. Should have current at terminals 3, 4 and 5. These terminals are internally connected in the P.T.O. switch when switch is moved to the start position. If you do not have current at terminals 3 or 4, the P.T.O. switch is bad and should be replaced. If okay go to step C.
- C. With P.T.O. switch still in the start position check for current at the P.T.O. clutch, black wire. If you're not getting current from the black wire to the P.T.O. clutch, you have a break in the wire or a poor connection. If okay go to step D.
- D. Check P.T.O. clutch air gap. Air gap should be .017. If okay go to step E.
- E. Follow evaluating instructions for checking condition of P.T.O. clutch.

2. P.T.O. engages but does not stay engaged. Engine continues to run. P.T.O. switch in run position.

NOTE: THIS TEST SHOULD BE PERFORMED WITH THE ENGINE OFF.

- A. Check P.T.O. air gap. Air gap should be .017.
- B. With P.T.O. in start position check for current at pin 4 of the P.T.O. switch. Brown wire. If not sensing current replace the P.T.O. switch. If okay go to step C.
- C. With the P.T.O. switch in the start position check for current at the common terminal on the reverse switch. The switch is normally closed and current should flow from the common terminal to the N.C. terminal or vice versa. If current is not flowing across the reverse switch, the switch is bad. Brown wires. If okay go to step D.
- D. With P.T.O. switch in start position check for current at terminal 2 of the reverse relay. Brown wire.

If not sensing current there the wire or connections between the reverse switch and the reverse relay are bad. If you are sensing current there the reverse relay is bad and should be replaced.

3. Engine stops when engaging P.T.O.

NOTE: THIS TEST SHOULD BE PERFORMED WITH THE ENGINE OFF.

4. P.T.O. does not engage when hot.

NOTE: THIS TEST SHOULD BE PERFORMED WITH THE ENGINE OFF.

5. P.T.O. Engaged. Operator leaves seat. Engine continues to run.

NOTE: THIS TEST SHOULD BE PERFORMED WITH THE ENGINE OFF.

- A. The operator must be sitting on the seat. The seat switch is a normally closed switch and when operator is in seat the switch is open.
- B. Check tractor seat switch; when operator sits on the seat you should have infinite resistance to current flow when checking with a multi-meter.
- C. If the seat switch is closed, when operator is sitting in the seat, the unit has the wrong seat switch or the switch is bad. Black wires.

A. Follow the procedures outlined in GT series clutches.

- A. Check seat switch as outlined in step 3.
- B. Check for current at seat relay terminal 2, with operator off of seat. If sensing current and engine is still running, replace the seat relay.

L.T. Serial Number 107,999 and Below

PTO Switch Off-1 & 2 On-3 & 4 Start-3&4&5	Key Switch Off-M & G Run-B & L Start-B&S
C Reverse Indicator N.C.—Relay Drops Out (Light On) N.O.—In Reverse	PTO Indicator N.C.—In Reverse N.O.—Light On
Blue Headlight Lead (725-3101)	Green
Blue (Front View)	Green
Indicator Light Lead (725-3115)	
R G BR Front View	BR G R W
W BK Indicator Lead	BK Primary Harness (725-3106)
Female Block Male Terminal	Male Block Female Terminal
Battery Tray Harness (725-3112)	
R Y G R Front View	R G Y R BK R BK
BK BR Battery Tray Harness	Primary Harness
Male Block Female Terminal	Female Block Male Terminal
16 HP Only 725-3113 Alternator Lead 725-3114 Magneto Lead	Alternator@ Engine

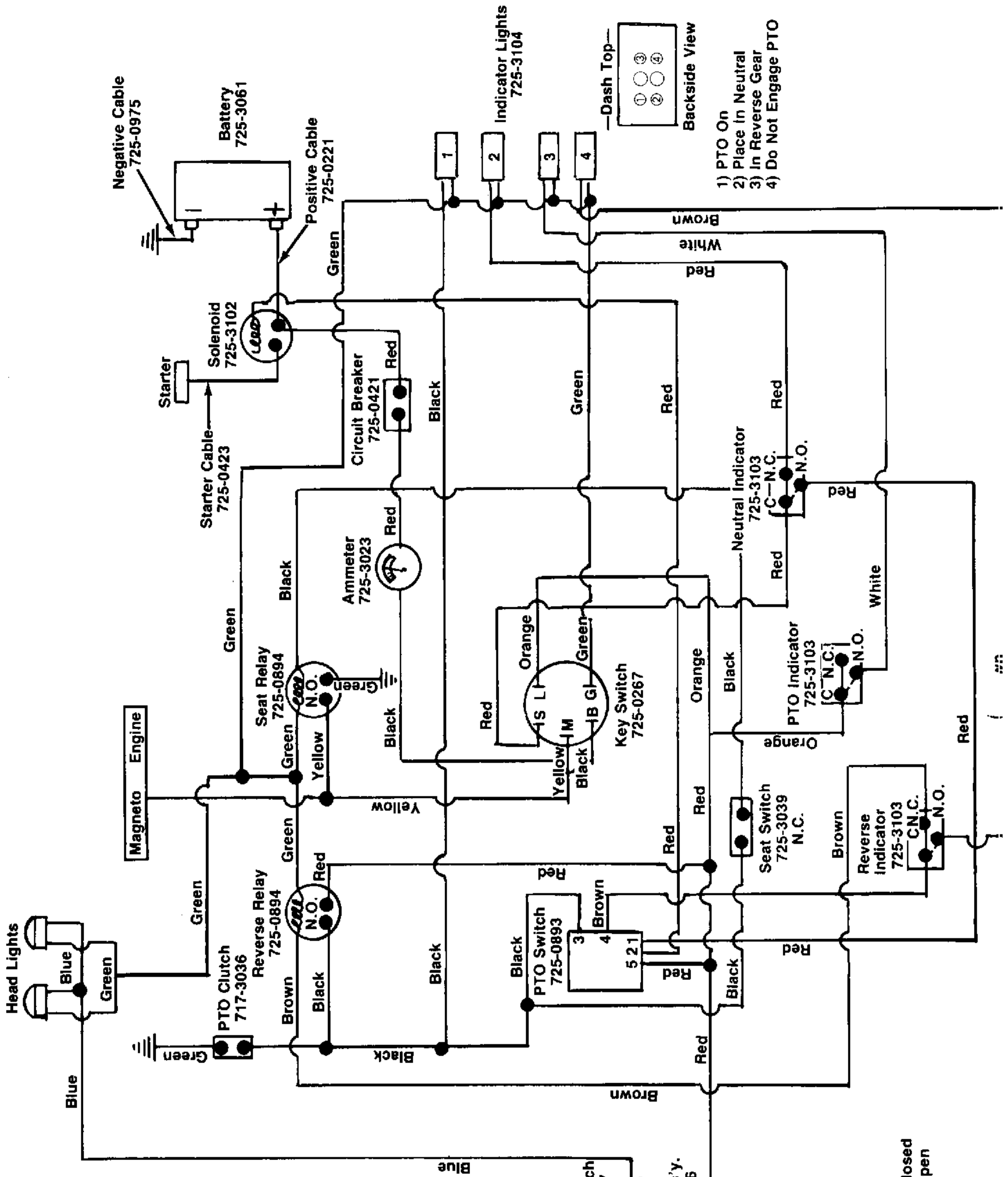

- 1) PTO On
2) Place In Neutral
3) In Reverse Gear
4) Do Not Engage PTO

N.C. = Normally Closed
N.O. = Normally Open

L.T. Serial Number 108,000 and Above
Serial Number 114,000 and Above

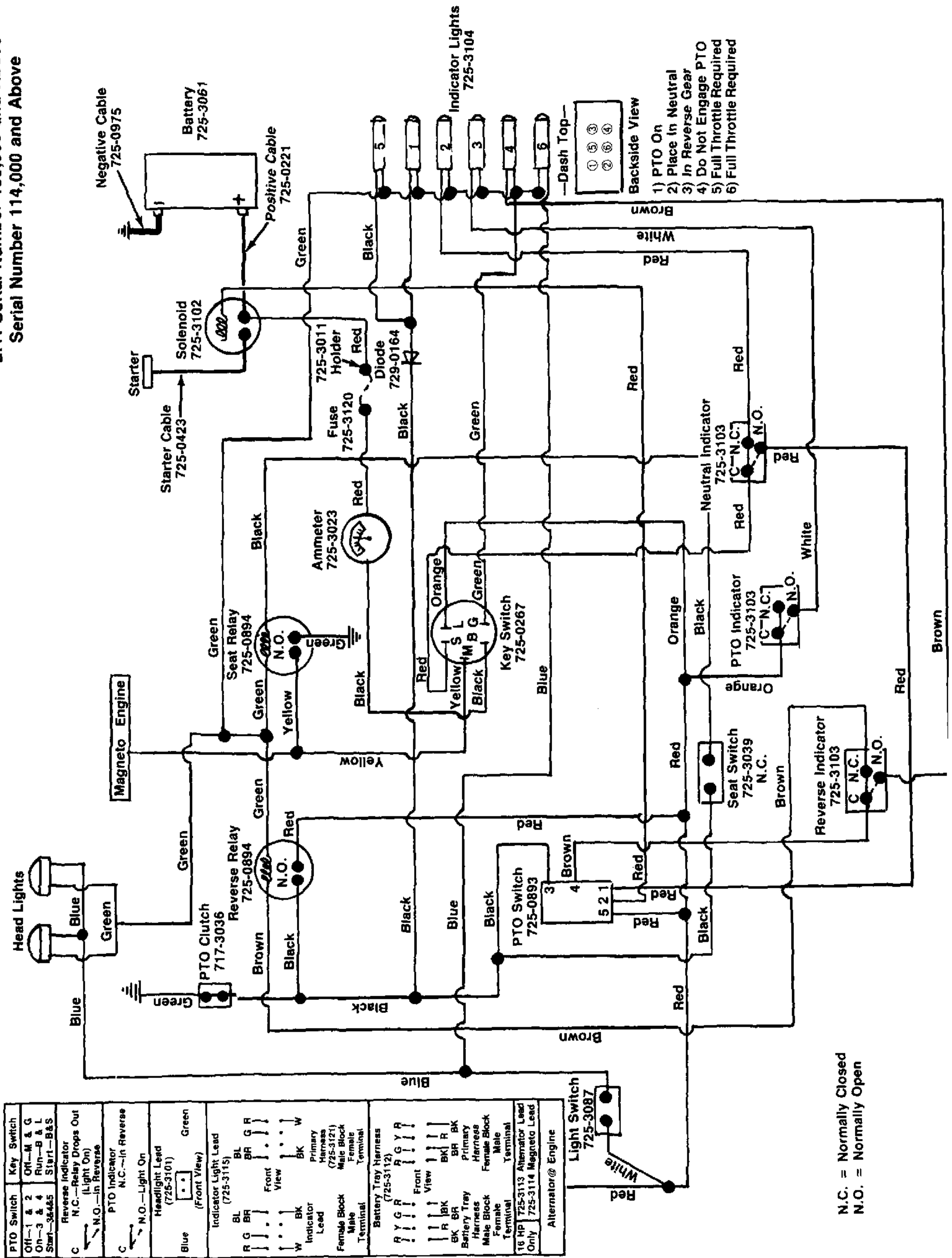

PTO Switch Off-1 & 2 On-3 & 4 Start-3&4&5	Key Switch Off-M & G Run-B & L Start-B&S
C	Reverse Indicator (Light On) N.C.—Relay Drops Out N.O.—In Reverse
C	PTO Indicator N.C.—In Reverse N.O.—Light On
Blue	Headlight Lead (725-3101) Green
BL BR R G W	Indicator Light Lead (725-3115) Front View BL BR G R W
W BK	Indicator Lead BK
Female Block Male Terminal	Primary Harness (725-3121) Male Block Female Terminal
Battery Tray Harness (725-3112) Front View R Y G R	Battery Tray Primary Harness (725-3121) Male Block Female Terminal
16 HP Only	725-3113 Alternator Lead 725-3114 Magneto Lead
Alternator@ Engine	

N.C. = Normally Closed
N.O. = Normally Open

Instructions for Evaluating VX Series Clutches

VX 5210-4	Cub P/N 717-3035
VX 5210-9	Cub P/N 717-3036

STEP 1

Measure Clutch Coil Resistance

1. Turn engine and P.T.O. switch off.
2. Disconnect clutch wire connection.
3. Select meter to check ohms.
4. Connect meter lead wires to the wires in the clutch connector (see figure 1).
5. If meter reads below 2.40 ohms or above 3.40 ohms, then the clutch has failed and needs to be replaced.

If meter reads between 2.40 and 3.40 ohms, proceed to Step 2.

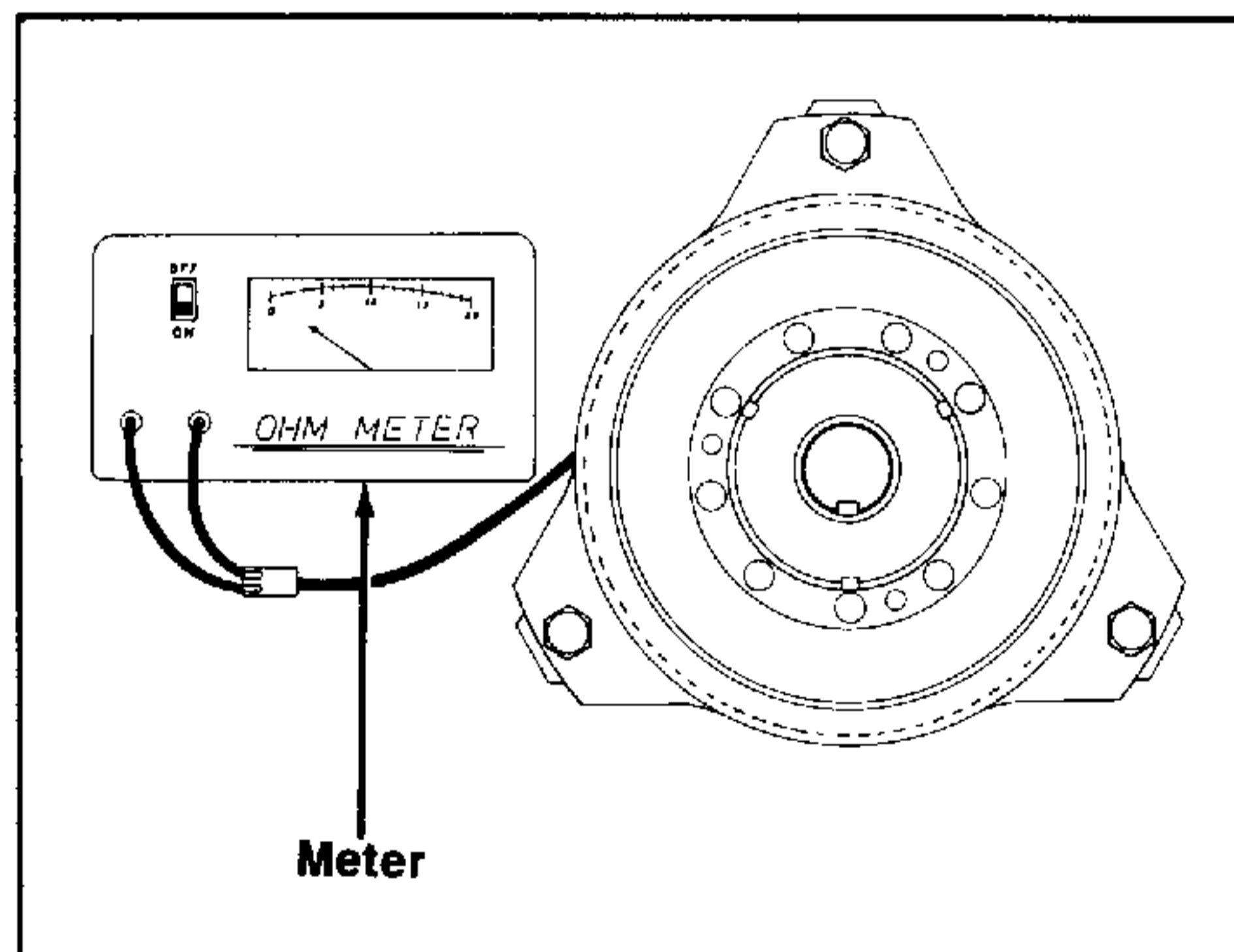

FIGURE 1.

STEP 2 Measure Clutch Current Draw

1. Turn engine off.
2. Disconnect clutch wire connection.
3. Select meter to check amps (10 amp scale).
4. Connect one meter lead wire to one wire in clutch connector (see figure 2).
5. Connect the other meter lead wire to the corresponding wire in the mating connector (see figure 2).
6. Connect a short wire to the 2nd wire in both connectors (see figure 2).
7. Turn P.T.O. switch on.
8. If meter reads below 3.5 amps, the problem would be in the electrical system leading to the clutch (battery, relay, switch, etc.)
If meter reads 3.5 amps or above, proceed to Step 3.

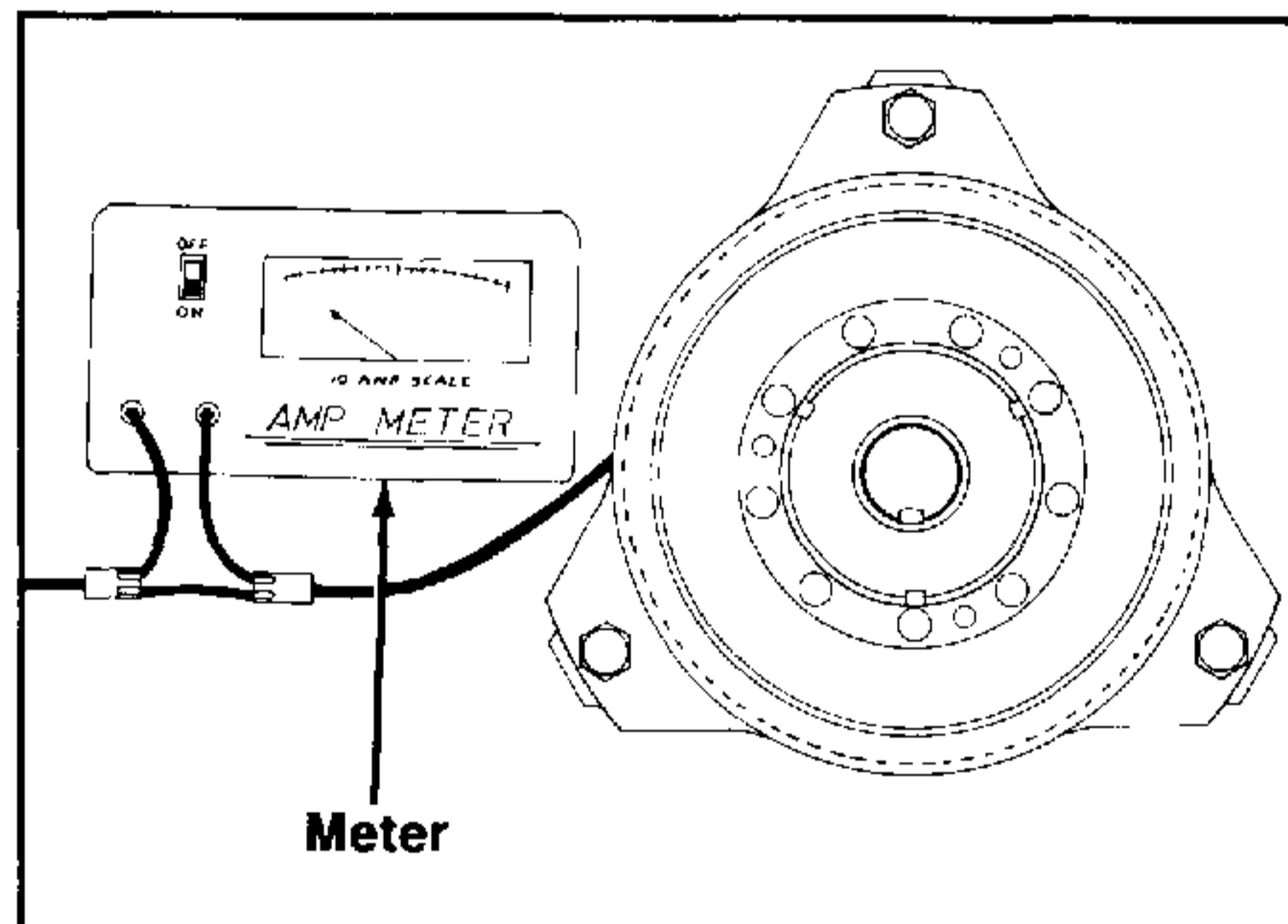

FIGURE 2.

STEP 3 Check Air Gap Setting

1. Turn engine and P.T.O. switch off.
2. Locate the three "windows" or "notches" where the air gap is checked (see figure 3).
3. With feeler gauge check gap at all three locations (minimum of two).
4. Factory air gap setting is .010"-.025".
5. If gap doesn't fall between .010"-.025" then reset using a .017" feeler gauge.
Changing the air-gap is achieved by tightening and/or loosening the three nuts.

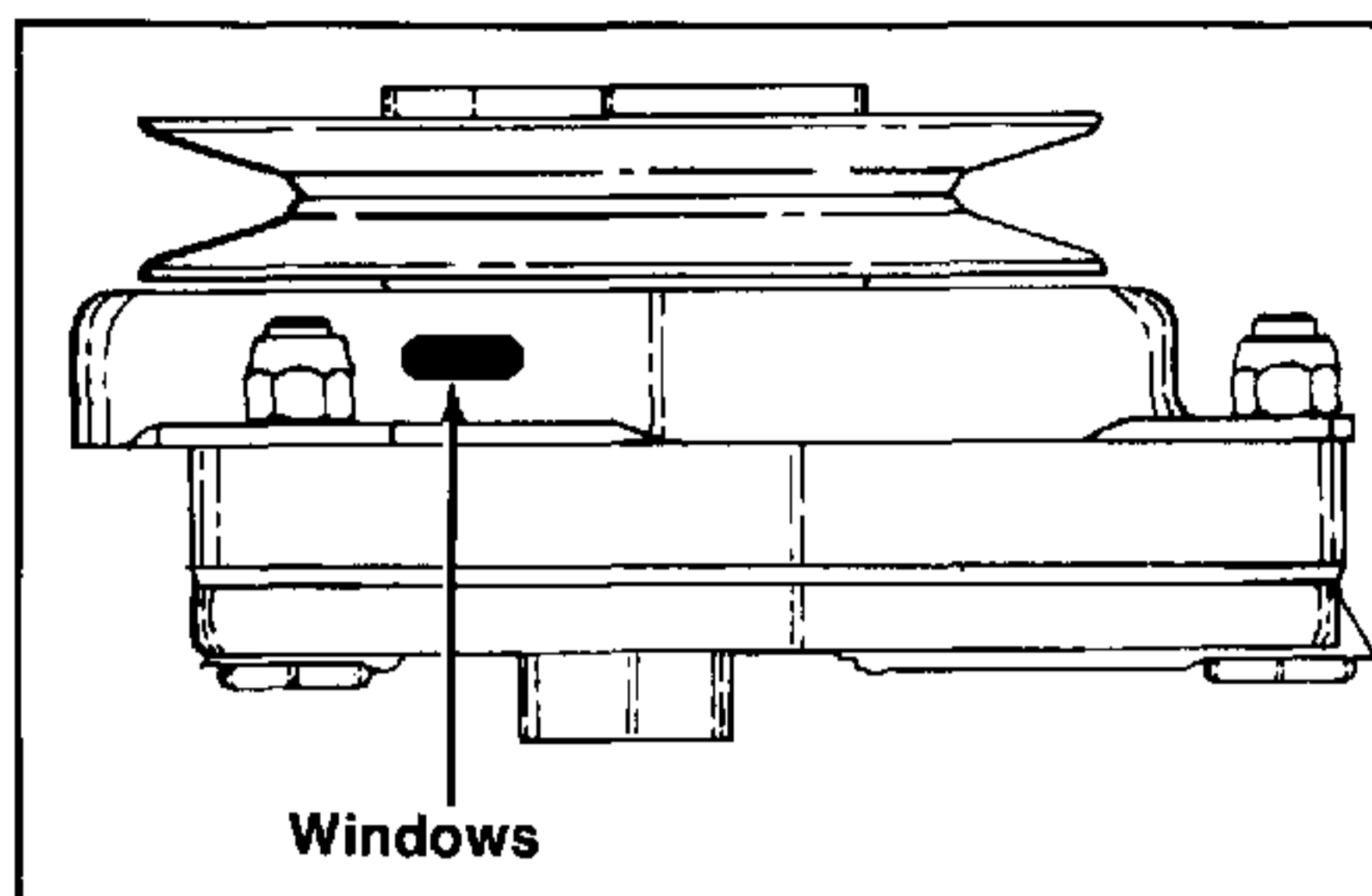

FIGURE 3.

If you find after completing Steps 1, 2 and 3 that:

1. The resistance falls between 2.40 and 3.40
2. The amp draw is 3.50 or above
3. The air gap is between .010"-.025" or reset to .017"

then the electric clutch is within factory specifications and is not the source of the problem.

Burnishing Procedure for Electric Clutch/Brake

To be performed after tractor is completely assembled.

1. Run at 50% throttle.
2. Engage and disengage the clutch 5 times. (10 seconds on/10 seconds off)
3. Increase to 75% throttle.
4. Engage and disengage the clutch 5 times. (10 seconds on/10 seconds off)

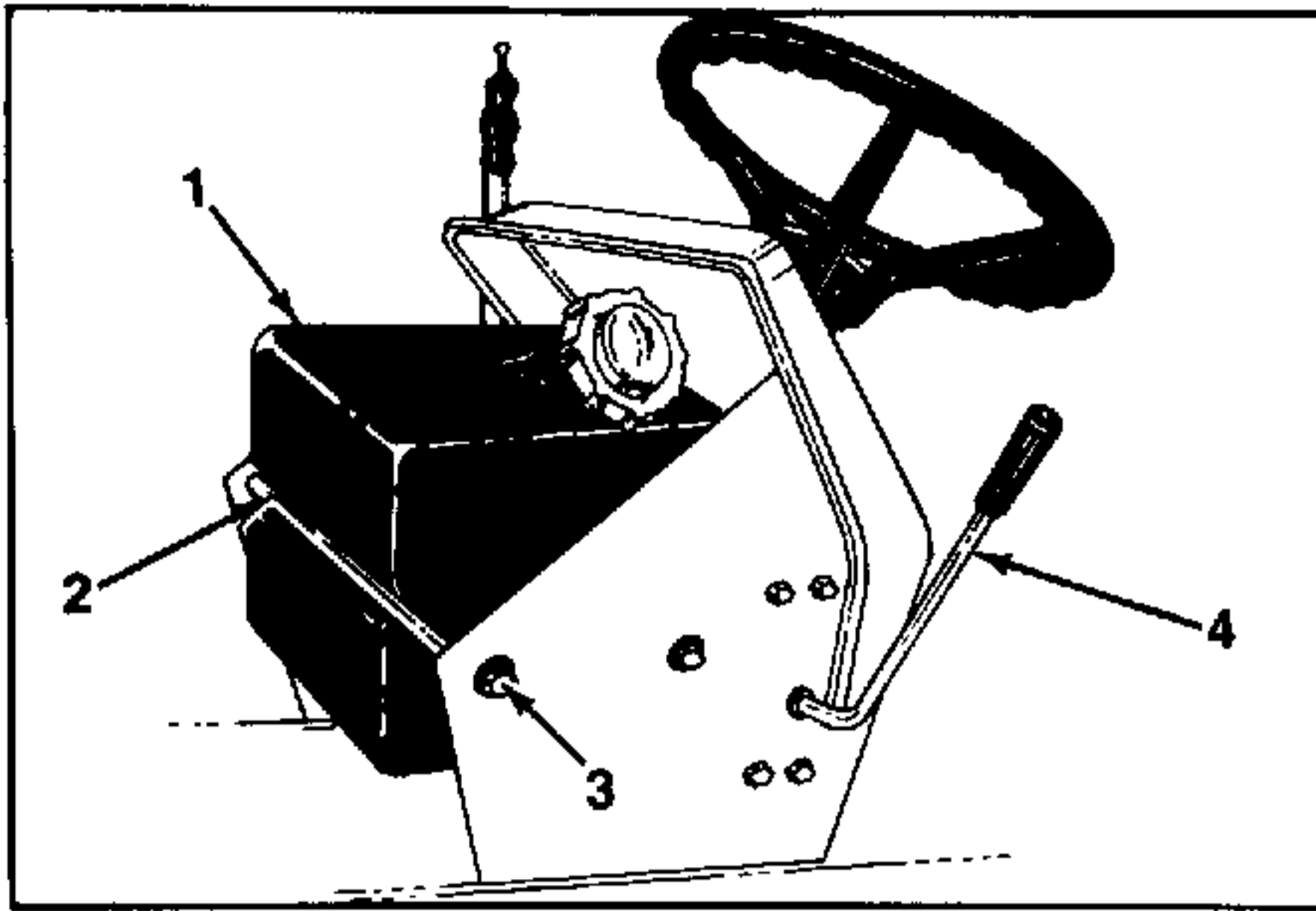

FIGURE 1.

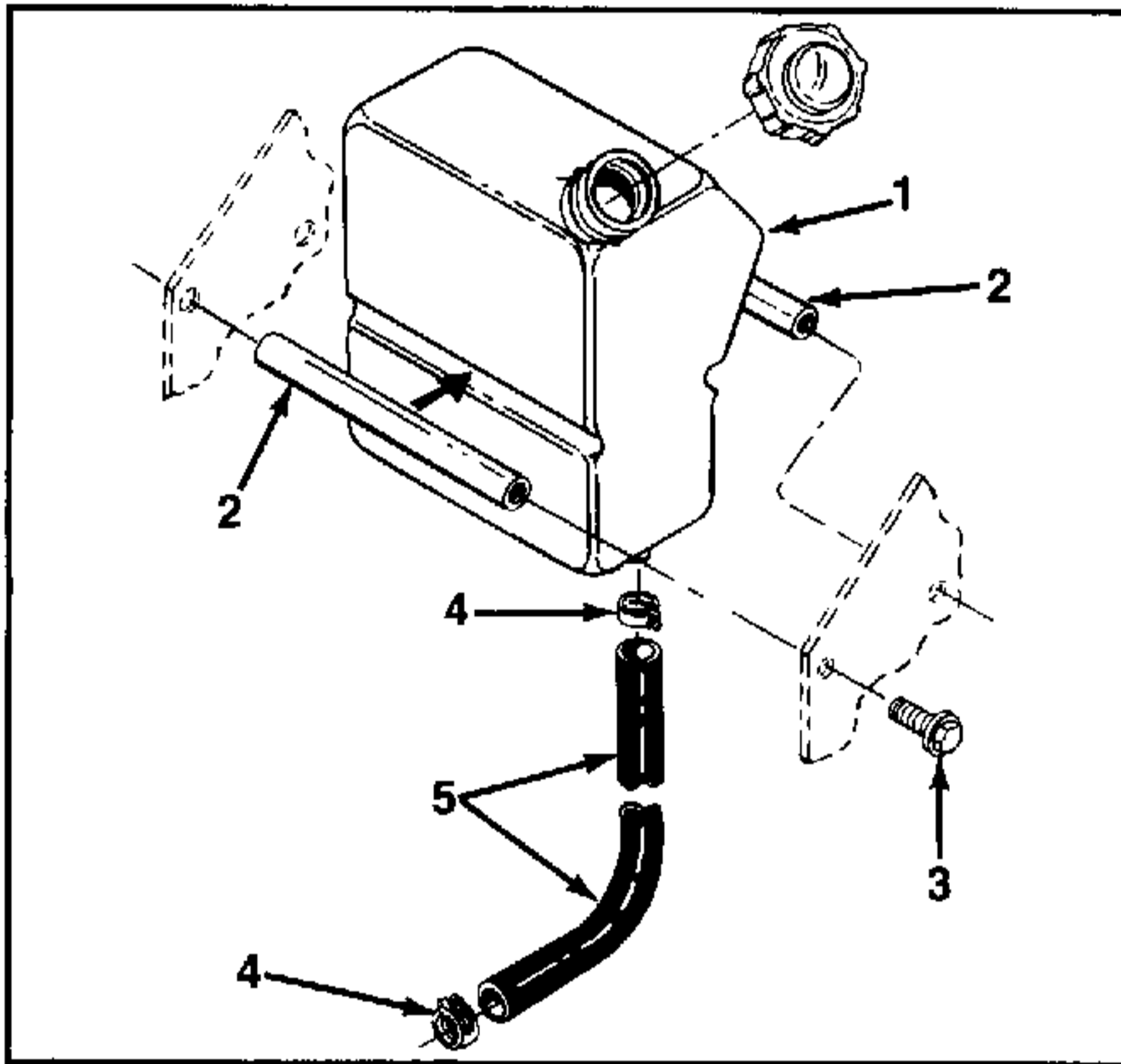

FIGURE 2.

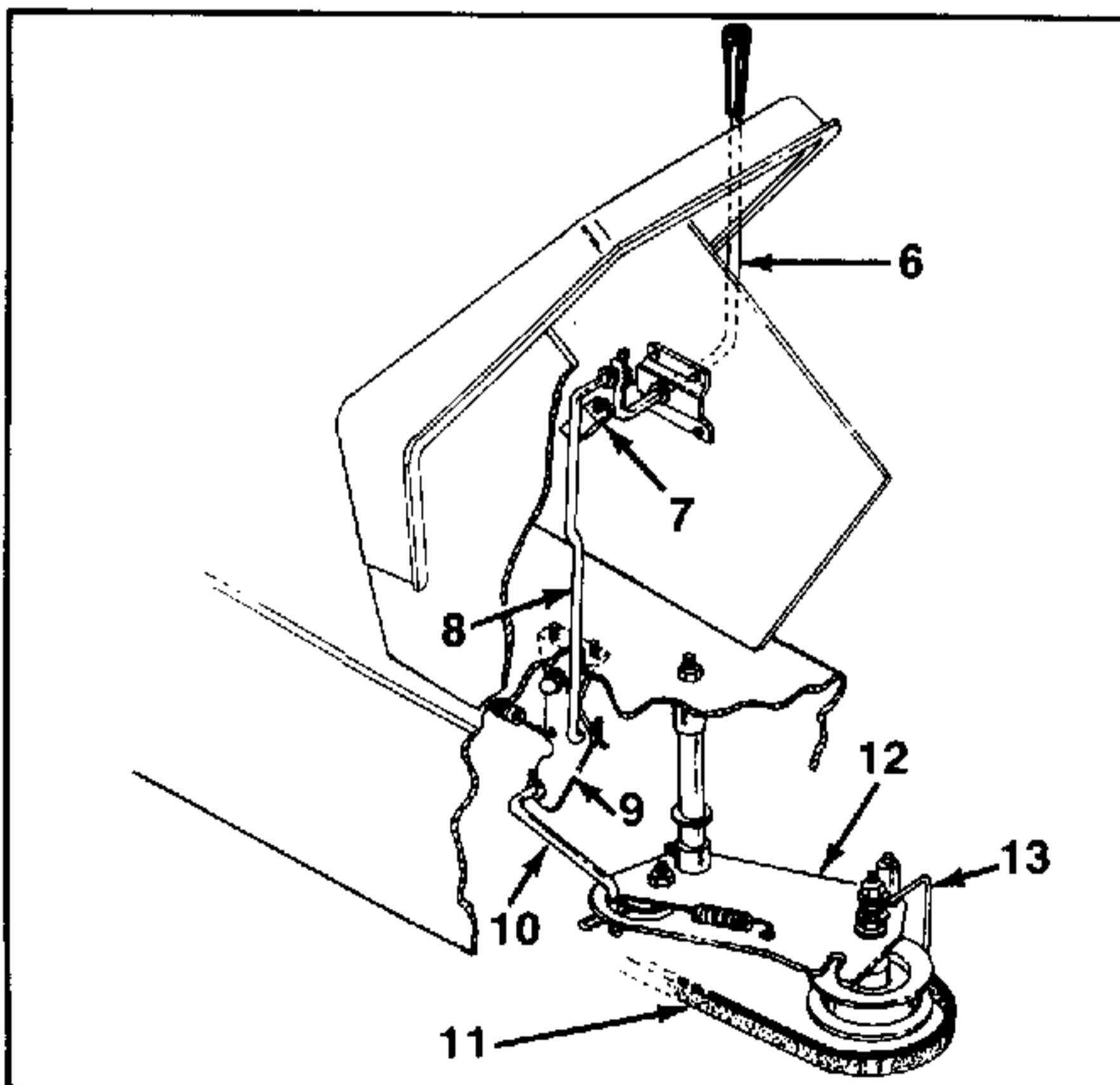

FIGURE 3.

MECHANICAL P.T.O.

For: (Models 1015, 1020, 1315 and 1320)

1. To disconnect P.T.O. clutch handle or replace the P.T.O. safety switch, you must remove the fuel tank.
2. Remove hex bolt from one end of fuel tank support rod. See figure 1.

NOTE

Drain fuel tank before proceeding.

3. Disconnect the fuel line, either at the fuel tank or fuel filter. See figure 2.

4. Remove the hairpin cotter and flat washer from P.T.O. clutch rod to gain access to the P.T.O. safety switch. See figure 3.

- | |
|--------------------------|
| 1. Fuel Tank |
| 2. Fuel Tank Support Rod |
| 3. Hex Bolt |
| 4. Hose Clamp |
| 5. Fuel Line |
| 6. P.T.O. Clutch Handle |
| 7. P.T.O. Safety Switch |
| 8. P.T.O. Clutch Rod |
| 9. Clutch Engagement Cam |
| 10. Clutch Rod |
| 11. Deck Drive Belt |
| 12. Manual Idler Arm |
| 13. Belt Guard |

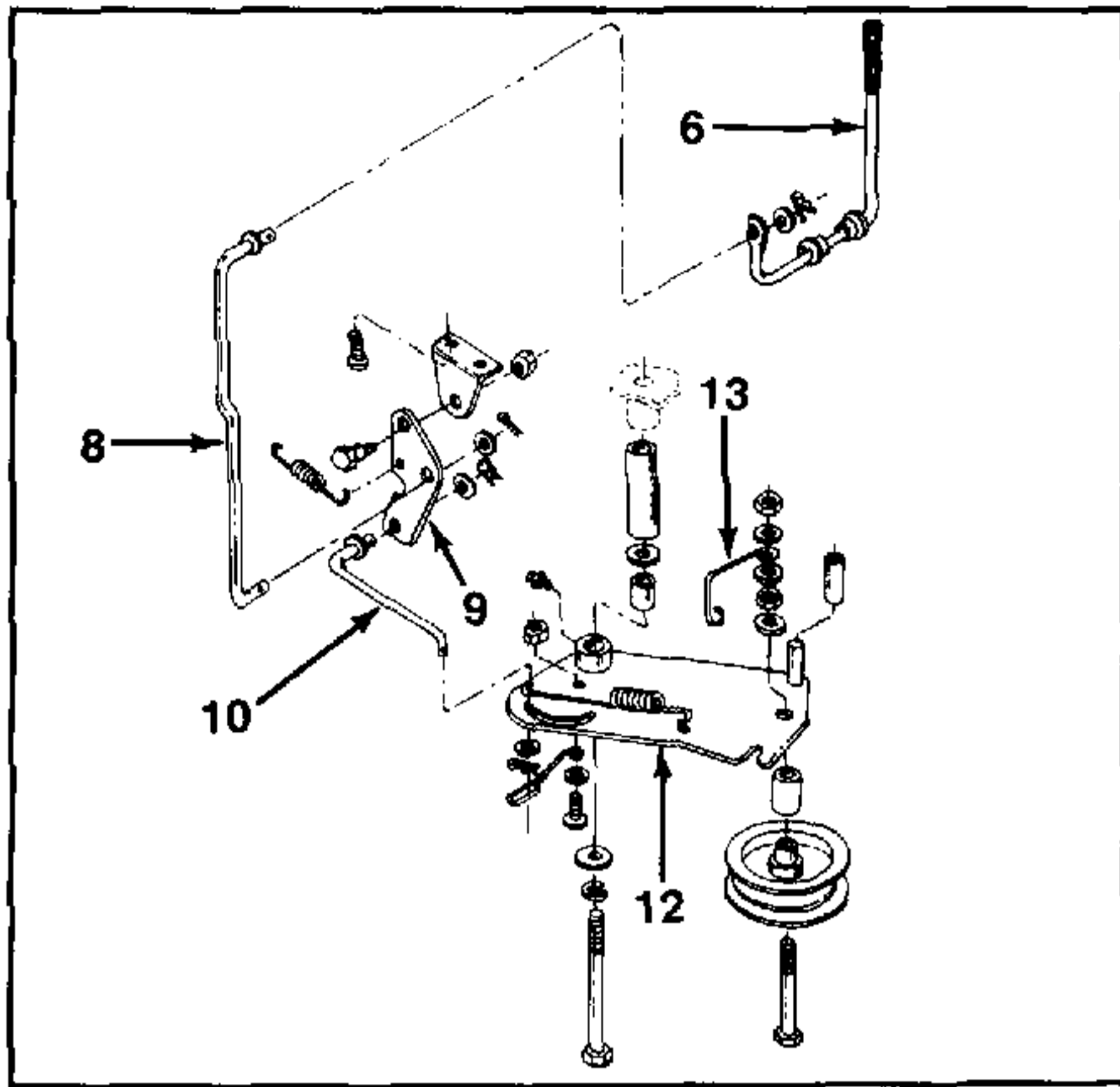

5. Deck belt replacement, requires loosening hex nut at manual idler arm and belt guard; pivot belt guard outward and remove belt. See figure 3 and 4.

- 6. P.T.O. Clutch Handle
- 8. P.T.O. Clutch Rod
- 9. Clutch Engagement Cam
- 10. Clutch Rod
- 12. Manual Idler Arm
- 13. Belt Guard

FIGURE 4.

SECTION 5

GENERAL INFORMATION AND SAFETY

Standard Torque Data for Inch Nuts and Bolts - Foot Pounds

Recommended torque for all standard unplated nuts and bolts, provided:

- A. Surface finish is oxide coated, oil quenched or bright.
- B. All threaded surfaces are clean and lubricated with SAE-30 engine oil or equivalent (see NOTE).
- C. Joints are rigid, that is, no gaskets or compressible materials are used.
- D. When reusing nuts or bolts, use minimum torque values.

NOTE: Multiply the standard torque by:



- .65 when finished jam nuts are used.
- .70 when Molykote, white lead or similar mixtures are used as lubricants.
- .75 when phosphate coated and oiled bolts or nuts are used.
- .85 when cadmium or zinc dichromate bolts or nuts are used.
- .90 when hardened surfaces are used under the nut or bolt head.
(this applies to standard unplated hardware only)

1 Foot Pound = 1.355 Newton Meters

Bolt or Stud Diameter	Type 2 Studs Only		Type 2 Bolts 6" Length or Less		Type 2 Bolts Longer Than 6"		Type 5 All Lengths		Type 8 - All Lengths			
									† Only When Used In Cast (gray) Iron		All Other Applications	
									Min.	Max.	Min.	Max.
1/4	5	6	6	7	4	4	9	10	11	13	13	14
5/16	12	13	11	13	7	8	18	20	22	25	25	28
3/8	21	24	21	24	13	14	33	37	41	46	45	50
7/16	35	38	35	38	20	23	53	60	65	74	75	85
1/2	52	58	52	59	31	35	80	90	100	112	115	130
9/16	70	80	75	85	45	51	115	130	145	160	165	185
5/8	98	110	104	117	62	70	160	180	200	225	225	255
3/4	174	195	185	205	180	200	285	320	355	400	400	450
7/8	280	315	265	300	265	300	460	575	570	640	645	725
1	420	470	380	425	380	425	685	720	855	960	970	1090
1-1/8	595	670	535	600	535	600	850	950	1210	1360	1375	1545
1-1/4	840	945	700	785	700	785	1200	1350	1705	1920	1940	2180
1-3/8	1100	1240	925	1045	925	1045	1570	1760	2235	2515	2540	2860

† When bolt penetration is 1-1/2 times the diameter of the bolt.

Bolt Type Identification Chart

SAE Grade	Description	Bolt Head Marking *
2	WILL BE BLANK IN THE CENTER OF THE HEAD Low or Medium Carbon Steel Not Heat Treated	
5	WILL HAVE 3 RADIAL LINES Quenched and Tempered Medium Carbon Steel	
8	WILL HAVE 6 RADIAL LINES Quenched and Tempered Special Carbon or Alloy Steel	

* The center marking identifies the bolt manufacturer.

Conversion Table - Inches to Millimeters

Inches	Millimeters	Inches	Millimeters	Inches	Millimeters	Inches	Millimeters
1	25.4	26	660.4	51	1295.4	76	1930.4
2	50.8	27	685.8	52	1320.8	77	1955.8
3	76.2	28	711.2	53	1346.2	78	1981.2
4	101.6	29	736.6	54	1371.6	79	2006.6
5	127.0	30	762.0	55	1397.0	80	2032.0
6	152.4	31	787.4	56	1422.4	81	2057.4
7	177.8	32	812.8	57	1447.8	82	2082.8
8	203.2	33	838.2	58	1473.2	83	2108.2
9	228.6	34	863.6	59	1498.6	84	2133.6
10	254.0	35	889.0	60	1524.0	85	2159.0
11	279.4	36	914.4	61	1549.4	86	2184.4
12	304.8	37	939.8	62	1574.8	87	2209.8
13	330.2	38	965.2	63	1600.2	88	2235.2
14	355.6	39	990.6	64	1625.6	89	2260.6
15	381.0	40	1016.0	65	1651.0	90	2286.0
16	406.4	41	1041.4	66	1676.4	91	2311.4
17	431.8	42	1066.8	67	1701.8	92	2336.8
18	457.2	43	1092.2	68	1727.2	93	2362.2
19	482.6	44	1117.6	69	1752.6	94	2387.6
20	508.0	45	1143.0	70	1778.0	95	2413.0
21	533.4	46	1168.4	71	1803.4	96	2438.4
22	558.8	47	1193.8	72	1828.8	97	2463.8
23	584.2	48	1219.2	73	1854.2	98	2489.2
24	609.6	49	1244.6	74	1879.6	99	2514.6
25	635.0	50	1270.0	75	1905.0	100	2540.0

1 Inch = 25.4 Millimeters

To convert inches to millimeters, the inch value to be converted should be written down, carried to as many decimal places as the desired accuracy requires. It should then be split into groups of not more than two figures each. The equivalent of each group should then be taken from the table, proper regard being given to the position of the decimal point in each case, and the equivalent values of the groups added together. This sum will be the millimeter equivalent of the inch value given.

For example, to convert 2.4635 inches to millimeters:

$$\begin{array}{r}
 2.0000 \text{ inches} = 50.80000 \text{ millimeters} \\
 .4600 \text{ inches} = 11.684000 \\
 .0035 \text{ inches} = \underline{\quad .08890} \\
 \hline
 2.4635 \text{ inches} = 62.57290 \text{ millimeters} \\
 \text{Correct to 3 decimal places.} \\
 2.4635 \text{ inches} = 62.573 \text{ millimeters}
 \end{array}$$

Conversion Table - Millimeters to Inches

Millimeters	Inches	Millimeters	Inches	Millimeters	Inches	Millimeters	Inches
1	.0393701	26	1.0236220	51	2.0078740	76	2.9921260
2	.0787402	27	1.0629921	52	2.0472441	77	3.0314961
3	.1181102	28	1.1023622	53	2.0866142	78	3.0708661
4	.1574803	29	1.1417323	54	2.1259842	79	3.1102362
5	.1968504	30	1.1811024	55	2.1653543	80	3.1496063
6	.2362205	31	1.2204724	56	2.2047244	81	3.1889764
7	.2755906	32	1.2598425	57	2.2440945	82	3.2283465
8	.3149606	33	1.2992126	58	2.2834646	83	3.2677165
9	.3543307	34	1.3385827	59	2.3228346	84	3.3070866
10	.3937008	35	1.3779528	60	2.3622047	85	3.3464567
11	.4330709	36	1.4173228	61	2.4015748	86	3.3858268
12	.4724409	37	1.4566929	62	2.4409449	87	3.4251968
13	.5118110	38	1.4960630	63	2.4803150	88	3.4645669
14	.5511811	39	1.5354331	64	2.5196850	89	3.5039370
15	.5905512	40	1.5748031	65	2.5590551	90	3.5433071
16	.6299213	41	1.6141732	66	2.5984252	91	3.5826772
17	.6692913	42	1.6535433	67	2.6377953	92	3.6220472
18	.7086614	43	1.6929134	68	2.6771654	93	3.6614173
19	.7480315	44	1.7322835	69	2.7165354	94	3.7007874
20	.7874016	45	1.7716535	70	2.7559055	95	3.7401575
21	.8267717	46	1.8110236	71	2.7952756	96	3.7795276
22	.8661417	47	1.8503937	72	2.8346457	97	3.8188976
23	.9055118	48	1.8897638	73	2.8740157	98	3.8582677
24	.9448819	49	1.9291339	74	2.9133858	99	3.8976378
25	.9842520	50	1.9685039	75	2.9527559	100	3.9370080

1 Millimeter = .03937008 Inch

To convert millimeters to inches, the millimeter value to be converted should be written down, carried to as many decimal places as the desired accuracy requires. It should then be split into groups of not more than two figures each. The equivalent of each group should then be taken from the table, proper regard being given to the position of the decimal point in each case, and the equivalent values of the groups added together. This sum will be the inch equivalent of the millimeter value given.

For example, to convert 75.384 millimeters to inches:

75.000	millimeters	=	2.9527559	inches
.380	millimeters	=	.0149606	
<u>.004</u>	millimeters	=	<u>.0001574</u>	
75.384	millimeters	=	2.9678739	inches
			Correct to 5 decimal places.	
75.384	millimeters	=	2.96787	inches

Standard Torque Data for Inch Nuts and Bolts - Newton Meters

Recommended torque for all standard unplated nuts and bolts, provided:

- A. Surface finish is oxide coated, oil quenched or bright.
- B. All threaded surfaces are clean and lubricated with SAE-30 engine oil or equivalent (see NOTE).
- C. Joints are rigid, that is, no gaskets or compressible materials are used.
- D. When reusing nuts or bolts, use minimum torque values.

NOTE: Multiply the standard torque by:



- .65 when finished jam nuts are used.
- .70 when Molykote, white lead or similar mixtures are used as lubricants.
- .75 when phosphate coated and oiled bolts or nuts are used.
- .85 when cadmium or zinc dichromate bolts or nuts are used.
- .90 when hardened surfaces are used under the nut or bolt head.
(this applies to standard unplated hardware only)

1 Newton Meter = 0.738 Foot Pound

Bolt or Stud Diameter	Type 2 Studs Only		Type 2 Bolts 6" Length or Less		Type 2 Bolts Longer Than 6"		Type 5 All Lengths		Type 8 - All Lengths			
									† Only When Used In Cast (gray) Iron		All Other Applications	
									Min.	Max.	Min.	Max.
1/4	7	8	8	9	5	5	12	14	15	18	18	19
5/16	16	18	15	18	9	11	24	27	30	34	34	38
3/8	28	33	28	33	18	19	45	50	56	62	61	68
7/16	47	52	47	52	27	31	72	81	88	100	102	115
1/2	71	79	71	80	42	47	109	122	136	152	156	176
9/16	95	109	102	115	61	69	156	176	197	217	224	251
5/8	133	149	141	159	84	95	217	244	271	305	305	346
3/4	236	265	251	278	244	271	387	434	482	543	543	611
7/8	380	427	360	407	360	407	624	780	773	868	875	984
1	570	638	516	577	516	577	929	977	1160	1303	1316	1479
1-1/8	807	909	726	814	726	814	1153	1289	1642	1845	1866	2096
1-1/4	1140	1282	950	1065	950	1065	1628	1832	2313	2605	2632	2958
1-3/8	1492	1682	1255	1418	1255	1418	2130	2388	3033	3412	3446	3881

† When bolt penetration is 1-1/2 times the diameter of the bolt.

Bolt Type Identification Chart

SAE Grade	Description	Bolt Head Marking *
2	WILL BE BLANK IN THE CENTER OF THE HEAD Low or Medium Carbon Steel Not Heat Treated	
5	WILL HAVE 3 RADIAL LINES Quenched and Tempered Medium Carbon Steel	
8	WILL HAVE 6 RADIAL LINES Quenched and Tempered Special Carbon or Alloy Steel	

* The center marking identifies the bolt manufacturer.

WORK SAFELY — FOLLOW THESE RULES



This symbol is used to call your attention to instructions concerning your personal safety. Be sure to observe and follow these instructions.

1. To prevent accidental starting, always pull the high tension wire(s) off the spark plug(s) before servicing and/or adjusting the machine.
2. To prevent injury, do not allow children or bystanders in the vicinity of the machine while it is being adjusted and/or serviced.
3. Do not wear jewelry (rings, wrist watches, necklaces, etc.) or loose fitting clothing when working on machinery; they could catch on moving parts, causing serious injury. Wear sturdy, rough-soled work shoes. Never adjust and/or service a machine in bare feet, sandals or sneakers.
4. Always wear safety glasses when using a hammer, chisel or other tools that may cause chips to fly.
5. Be sure to reinstall all safety devices, guards or shields after adjusting and/or servicing the machine.
6. When operating a power washer to clean a machine before servicing, be careful at all times to avoid injury. Maintain proper footing and balance at all times. Never direct the spray at people or animals, as high pressure spray can cause serious injury.
7. If a portable heater is used to heat the service area, the following precautions must be observed:
 - a. Do not use portable heaters in the presence of volatile materials such as gasoline, paint or paint thinner. A fire or explosion may result.
 - b. When in operation, locate the heater away from the immediate work area to avoid accidental contact, which could result in severe burns or ignite your clothing.
 - c. Portable heaters consume oxygen and emit hazardous combustion fumes. A heater should be used only in a well ventilated area. Keep a window or door partially open to provide ventilation.
 - d. Keep the heater at least four feet from all combustible materials.
 - e. Never use gasoline as fuel.
8. Gasoline is highly flammable — observe the following precautions when handling gasoline:
 - a. Use an approved gasoline container.
 - b. Never remove the fuel tank cap or fill the fuel tank when the engine is running, is hot, or is indoors. **DO NOT SMOKE** when working around flammable fuel.
 - c. Avoid fires — be sure container or funnel does not touch the battery. Do not overfill the fuel tank. Wipe up all spilled gasoline.
 - d. Replace fuel tank cap securely.
9. Never use trouble lights or electric powered tools that have cut or damaged cords or plugs. Be sure all electric tools are properly grounded.
10. Never run an engine in a confined area, such as a garage or storage building, any longer than is necessary for immediate moving of the machine out of or into the area. **EXHAUST GASES ARE TOXIC. OPENING DOORS AND WINDOWS MAY NOT PROVIDE ADEQUATE VENTILATION.**
11. After servicing, be sure all tools, spare parts, and/or servicing equipment are removed from the machine.
12. Electrical storage batteries give off highly flammable hydrogen gas when charging, and continue to do so for some time after receiving a steady charge. Do not, under any circumstances, allow an electrical spark or an open flame near the battery. Always disconnect the battery cables (negative cable first) before working on the electrical system.
13. Hydraulic fluid escaping under pressure can have enough force to penetrate the skin. Hydraulic fluid may also infect a minor cut or opening in the skin. If injured by escaping fluid, see a doctor at once. Serious infection or reaction can result if medical treatment is not given immediately.

Do not attempt to repair or tighten hoses that are under pressure or with the tractor engine running. Cycle all hydraulic control valves to relieve all pressure before disconnecting lines or performing other work on the hydraulic system. Make

sure all connections are tight and hoses and lines are in good condition before applying pressure to the system. To locate a leak under pressure, use a small piece of cardboard or wood. Never use your hands.

14. When using a welder or acetylene torch, always wear welding goggles and gloves. Keep a charged fire extinguisher within reach. Do not weld or heat areas near the fuel tank, fuel lines, hydraulic lines, or battery.
15. Always use safety stands in conjunction with hydraulic jacks or hoists. Do not rely on the jack or hoist to carry the load; it could fail, causing serious injury and/or damage. Be sure jack stands are properly positioned to prevent tipping or roll-over.
16. When removing supporting components or disassembling machines, be sure to use safety stands and adequate supports to prevent tipping or rollover and to prevent components from falling.

17. Use a safety catch on all hoist hooks. Do not take a chance, the load could slip off the hook.
18. Use pullers to remove bearings, bushings, gears, sleeves, etc. when applicable. Use hammers, punches and chisels only when absolutely necessary. Then, be sure to wear safety glasses.
19. Petroleum based solvents used for cleaning parts are flammable. Use care to avoid fire or explosion when using these solvents.
20. Be careful when using compressed air to dry parts. Use approved air fixtures, do not exceed 30 psi, wear safety glasses or goggles, and use proper shielding to protect everyone in the work area.

IMPORTANT: The above is only a partial list of safe work rules. In addition, always refer to the Operator's Manual for the specific machine for additional safe work rules regarding the machine operation.

ACTIVATING A BATTERY

HOW YOU ACTIVATE THIS BATTERY WILL AFFECT ITS LIFE AND PERFORMANCE.

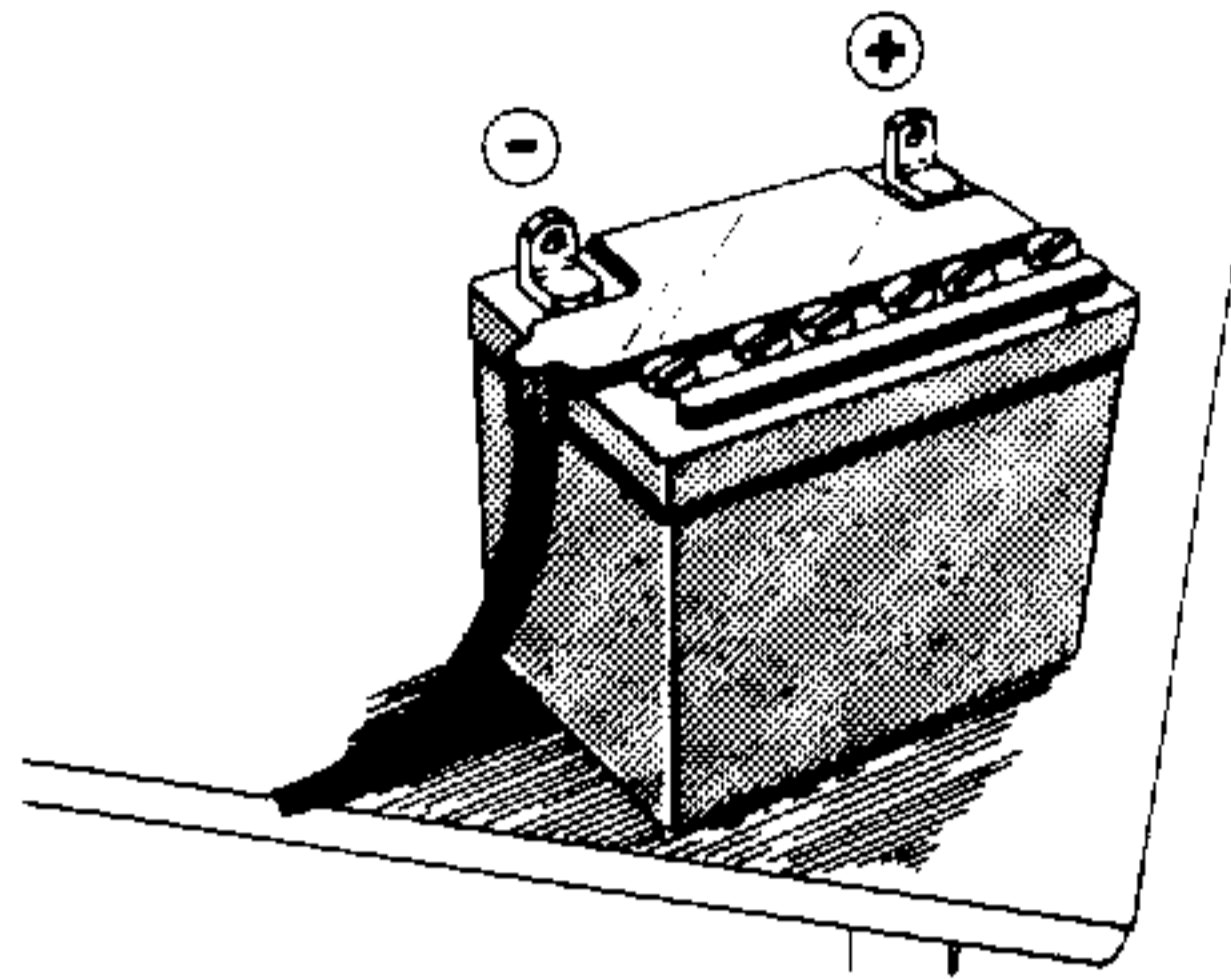

1. Remove battery from tractor. Place on a bench or table.

2. Fill each cell to the top of the plates.



WARNING

ELECTROLYTE IS DILUTED SULFURIC ACID. USE EXTREME CARE TO AVOID SPILLING. IT CAN DESTROY CLOTHING AND BURN YOUR SKIN.



NOTE

When battery is charged, the heat will expand the electrolyte.

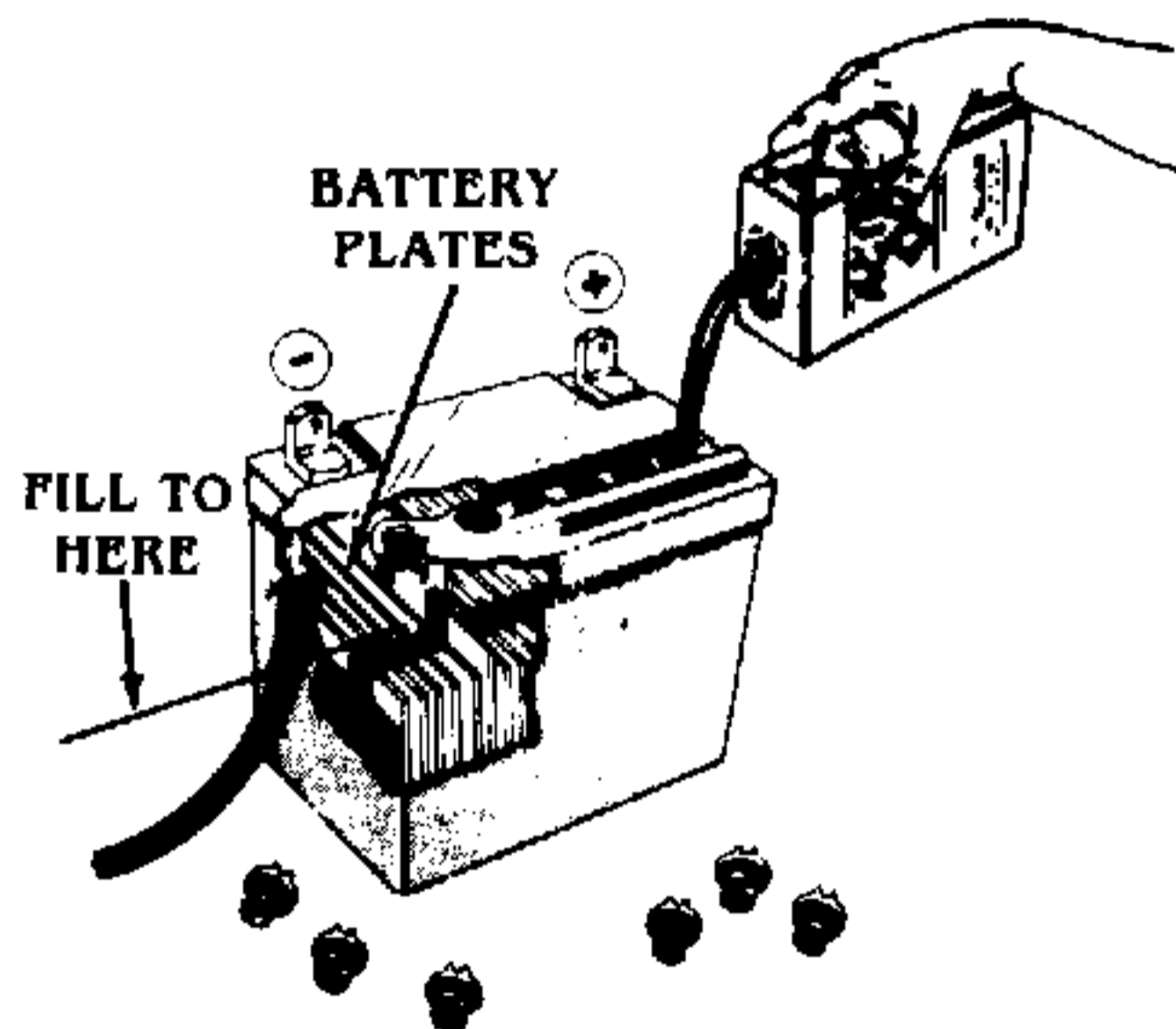

3. Allow the battery to sit 30 minutes. This allows the chemical action to take place.

4. Charge the battery at the rate recommended on the previous page until the specific gravity is at least 1.250.



CAUTION

Charging the battery at more than the recommended rate will cause the plates to warp and short out your battery.

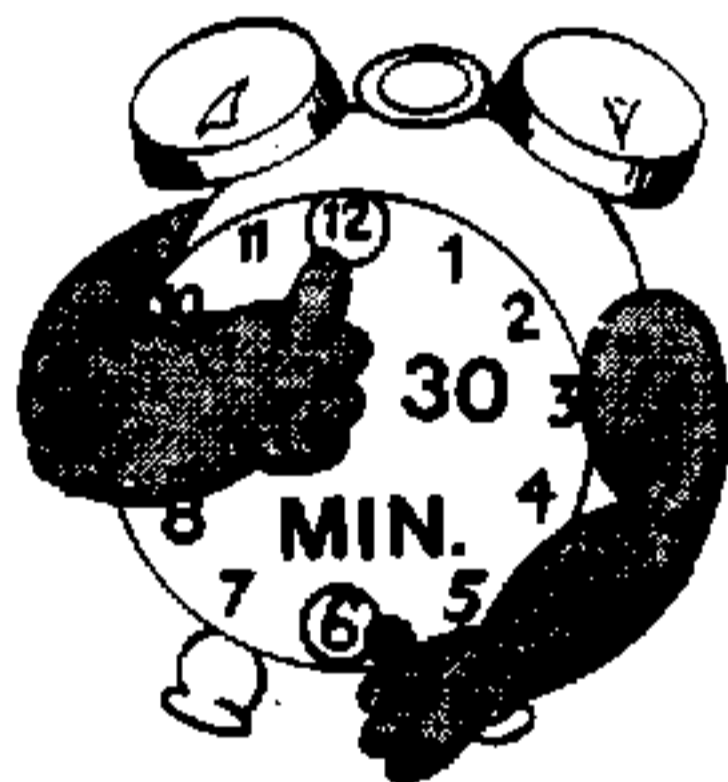

5. Check the level of electrolyte in all cells and add if necessary, to bring the level up to the SPLIT RING.

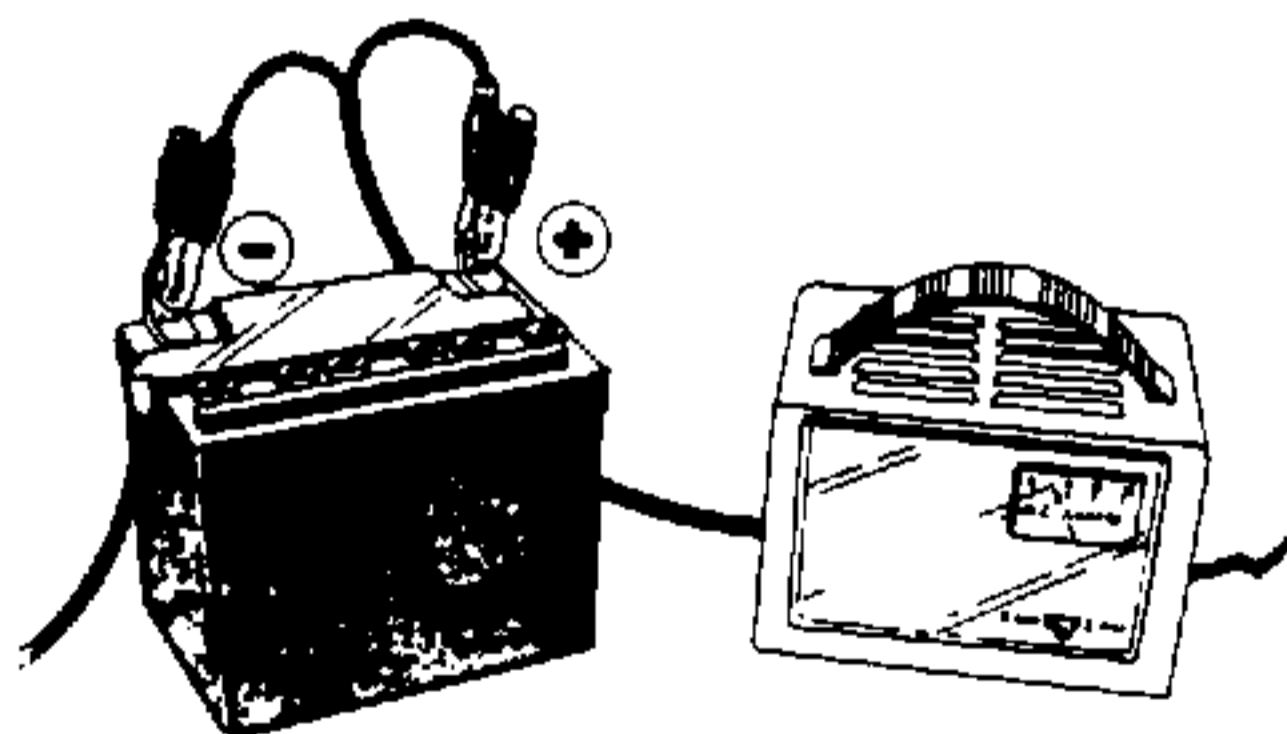

6. Wash off any spilled electrolyte.

7. Install the battery in tractor.

+ ATTACH THE POSITIVE CABLE FIRST.

- ATTACH THE NEGATIVE CABLE LAST.

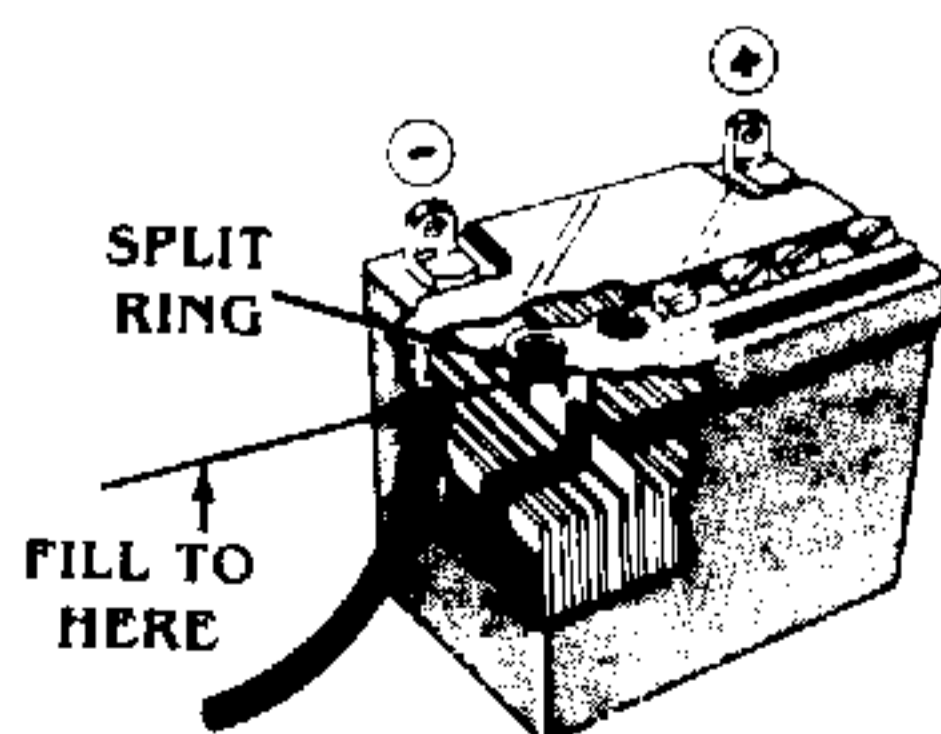

8. Attach the battery hold down.

9. IF YOU HAVE TAKEN TIME TO PROPERLY INSTALL THE BATTERY, IT WILL GIVE YOU A LONG LIFE.

