

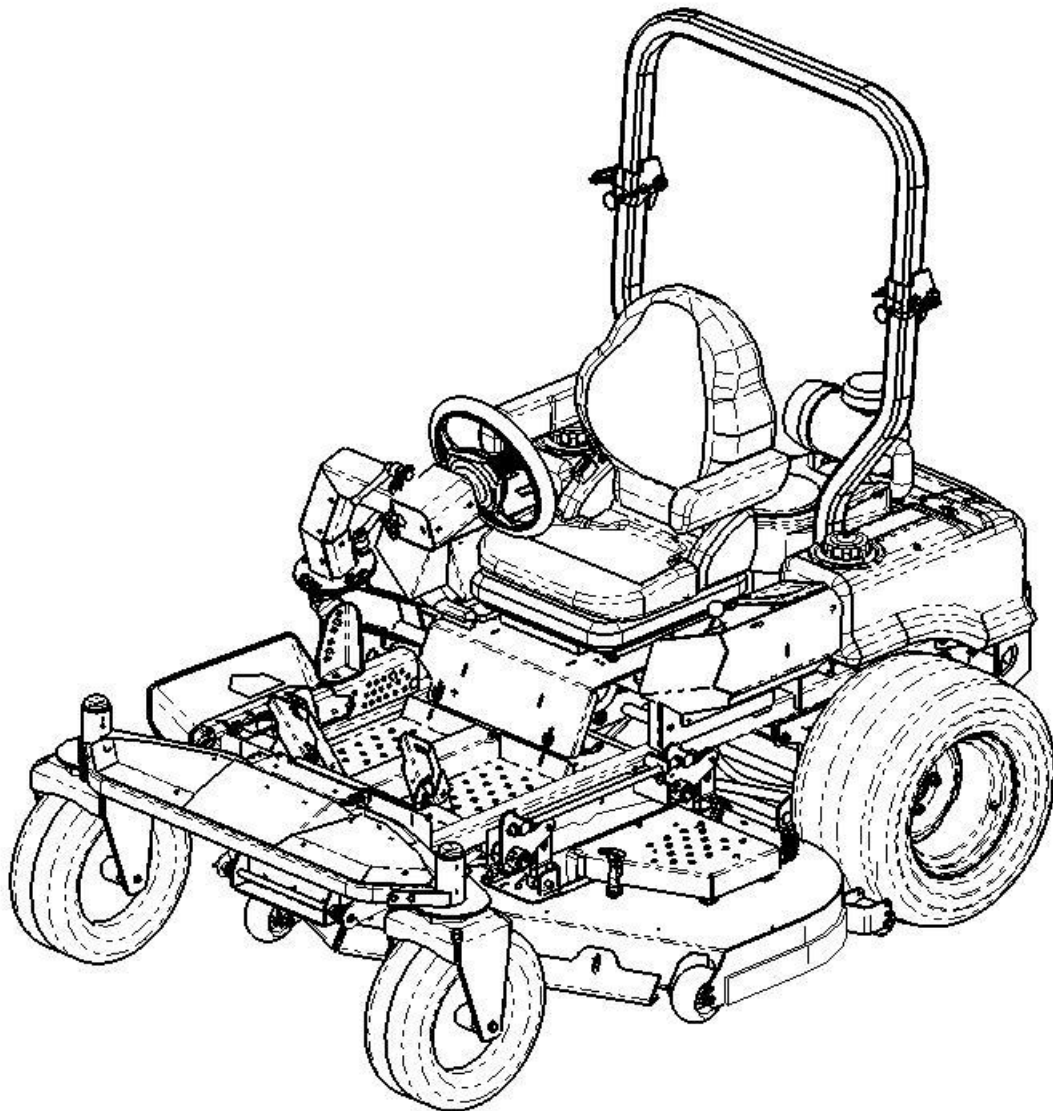

TANK - S ELECTRICAL SYSTEM



Model Year 2009



TANK - S ELECTRICAL SYSTEM

TABLE OF CONTENTS:

PAGE 3) **PRIMARY WIRE COLOR DESIGNATION:**
Red.
Green.
Orange.
Yellow.
Blue.
PRIMARY COMPONENTS:
Battery.
Fuses.
Seat Switch.

PAGE 4) **PRIMARY COMPONENTS: cont.**
Ignition Switch.
Relay Switch.

PAGE 5) **PRIMARY COMPONENTS: cont.**
Brake Switch.
PTO Switch.
Wire Harness.

PAGE 6) **CIRCUIT ROUTING:**

PAGE 7) **WIRE DIAGRAM:**

PAGE 8) **DIAGNOSTICS:**
Prevention.
Symptom / Diagnostics.

PRIMARY WIRE COLOR DESIGNATION:

RED or Combination as Red w/ Black Stripe.

POSITIVE (+) power supply.

Circuit runs from battery, thru a fuse, to the ignition switch for distribution to components as Starter Solenoid (orange wire), Relays and Charging System.

GREEN:

NEGATIVE (-) main Ground Circuit.

Main Circuit runs from Battery to Engine Block and to components requiring constant ground.

ORANGE or Combination as Orange w/ Black or White Stripe.

POSITIVE (+) power supply to activate the engine starter solenoid.

Circuit begins at the ignition switch and is tied directly into safety switches before ending at the starter solenoid.

Example, when the brake is engaged, the brake switch makes the orange wire circuit and allows the current to flow to the next component. When the brake is off the circuit is broken within the switch and the current cannot flow to the next component, therefore the engine starter will not engage.

YELLOW or Combination as Yellow w/ Black or White Stripe.

NEGATIVE (-) circuit ground to engine magneto.

Circuit begins at the ignition switch and is tied directly into safety switches and relays before ending at the engine. This circuit provides a means to ground the engine magneto which in turn does not allow the engine to provide spark to the spark plugs.

BLUE or Other Colors:

These are secondary circuits providing current to components and accessories.

Example, BLUE Wire provides positive (+) current to activate the PTO clutch.

PRIMARY COMPONENTS:

BATTERY:

12 Volt, CA @ 32 deg.F = 320, CCA @ 0 deg.F = 260.

NEGATIVE CABLE to the engine block mounting bolt.

POSITIVE CABLE to the engine starter solenoid.

POSITIVE WIRE, main circuit to fuse and ignition switch.

Note: On Diesel, EFI or DFI engines, some components are connected directly to the battery with their own circuit and fuse. Consult the appropriate wire schematic for routing.

FUSE:

Blade Type, Automotive, 20 amp for main circuit from battery to ignition switch.

Note: On TANK-S Units the fuse & labeled holders are mounted on the inside lip of the RH side control panel next to the battery.

SEAT SWITCH:

The operator presents (seat) switch is integrated in the seat cushion. When the operator is in the seat, a positive circuit is completed sending current to a relay or other safety component within the system.

PRIMARY COMPONENTS: Cont.

IGNITION SWITCH: Pole Contact per Key Position.

OFF – “G” Green is Ground + “M”, Yellow Wire the Magneto. + “R” Accessory.
Are Closed Circuits.

Engine Magneto is grounded and will not produce spark to spark plugs.
“B” Red Positive is isolated. Not feeding other circuits.

ON – “B” Red Positive from Battery to “L” Red Wire to feed circuits & “R” Positive to Acc.

Positive Current is sent to components as PTO switch, relay, seat, and engine harness.
Magneto is no longer grounded at key switch but is still depending on safety switches to allow the engine to produce spark to spark plugs.
“S” Orange Wire has no current.

START – “B” Red Positive from Battery + “S” Orange Wire to Engine Starter Solenoid + “L” Red to feed circuits.

Positive current is routed thru the orange wire to activate the engine starter solenoid.
The complete circuit is dependent on the safety switch system in order to activate the starter.

Positive Current is sent to components as PTO switch, relay, seat, and engine harness.
Magneto is no longer grounded at key switch but is still dependent on safety switches to allow the engine to produce spark to spark plugs.

IGNITION SWITCH: 6 pole, key activated. View From POLE Side

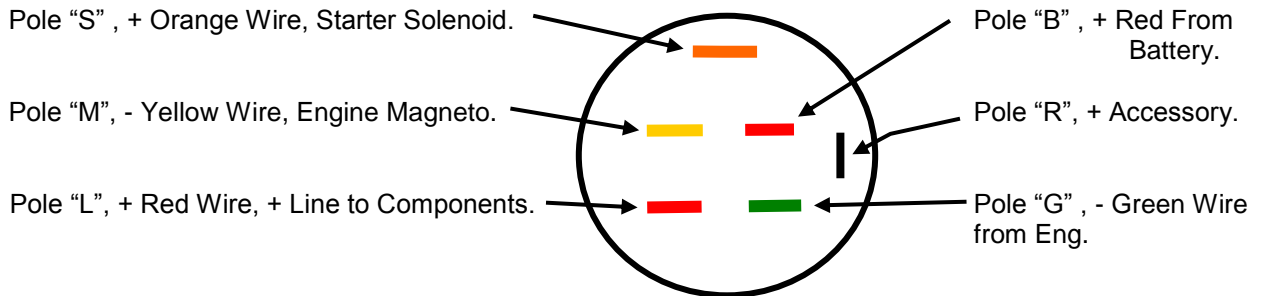

RELAY SWITCH:

This type of switch is activated by current introduction. In our system, it’s used to open or close a circuit, (positive or negative), transfer current or to stabilize amperage to protect related components.

In the TANK-S harness, the relay feeds a ground from 2 yellow leads to the engine magneto. Engine will not start with yellow magneto circuit grounded. When the operator sits in the seat the positive circuit is closed and current is sent to the relay to open the yellow wire magneto ground circuit.

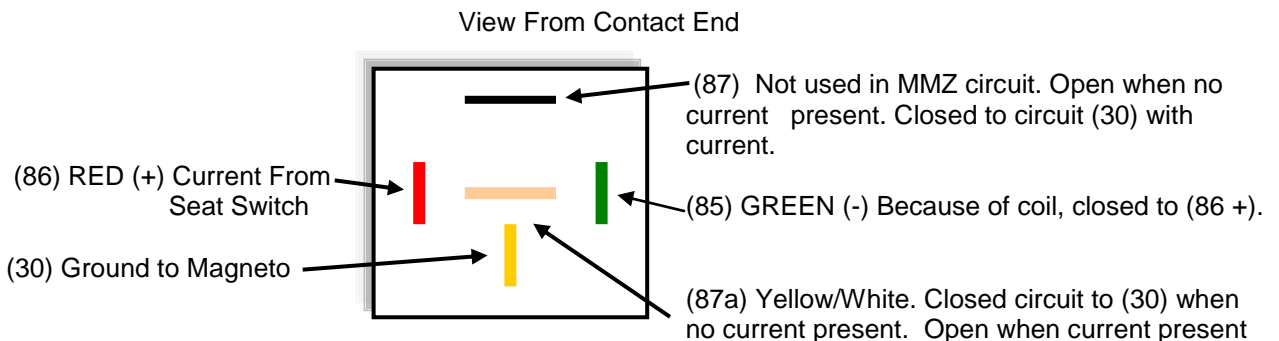

BRAKE SWITCH:

This is a manually operated safety switch. When the brake is in the engaged position, switch button in, the orange wire (starter circuit) is closed allowing current to pass thru from the ignition switch. The circuit between the green ground and yellow (magneto) is open. With the brake disengaged, the open and closed circuits are reversed.

Yellow Wire to Relay (87a).
Closed to Ground, Brake Off

Green Ground to Yellow w/
Brake Off.



Orange from Ignition Switch to
PTO Switch. Open Circuit when
Brake is Off

PTO SWITCH:

A manually activated switch to provide current (+) to the PTO clutch with provisions to regulate the starter and magneto circuits. With switch in the off position, orange circuit (starter) is closed. The green (ground) to yellow (magneto) circuit and red (+) to blue (PTO clutch) are open. This allows the current to flow to the starter.

When the switch is engaged, the orange circuit (starter) is open, green (ground) to yellow (magneto) is closed and red (+) to blue (PTO clutch) is also closed. This disables the starter circuit and enables the PTO clutch to engage. The closed or grounded magneto circuit which normally would shut the engine down is opened at the relay via the seat switch which brakes the ground circuit to the engine.

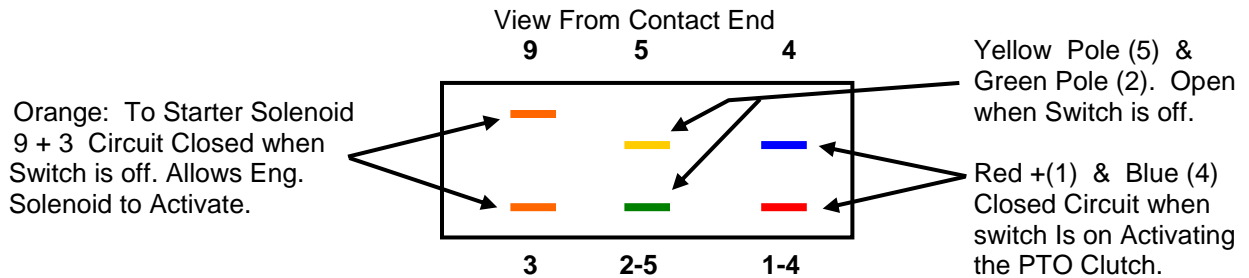

WIRE HARNESS:

The main wire harness is common for all AIR COOLED ENGINES. It is configured to match a Kohler Engine internal starter solenoid and supply plug. The same harness is used for Kawasaki Engines by adding a short "pig tail" to the engine plug matching the Kawasaki wire group and leads to supply the external starter solenoid.

The TANK-S Unit has a hydraulic oil cooling system incorporating a heat exchanger and cooling fan. The fan circuit is a red wire tied into the positive circuit at the engine voltage regulator and grounded to the engine block. The fan is activated when the ignition key switch is turned on.

EFI, DFI, COMPUTERIZED ENGINES as Kawasaki Horiz.. Liquid Cooled use the same basic wire color-coding. But, because of the computer, fuel pump and indicator lights, 2 relays and 1 fuse have been added to feed and protect these additional components.

The DIESEL UNIT wire harnesses are unique to that unit. The engine is shut down thru positive (+) current not magneto grounding as a gasoline engine. Because of the many supportive components as indicator lights, cooling fan, glow plugs etc. additional fuses and relays are incorporated in the system.

The PTO CLUTCH can generate current that can feed back into the system. The current spike can damage components as relays and computers. Units with EFI, DFI and Diesel engines have a diode in the circuit supplying current to the clutch.

Consult the wire diagram for detail routing.

CIRCUIT ROUTING, TANK-S AIR COOLED ENGINES:

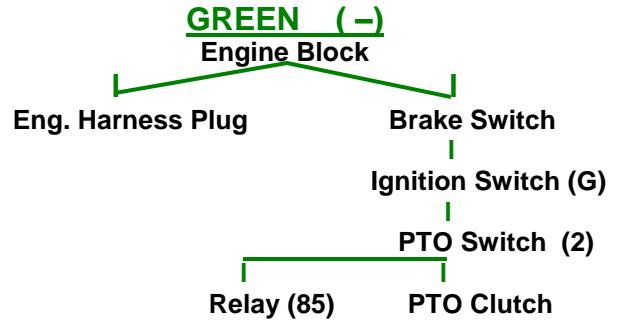
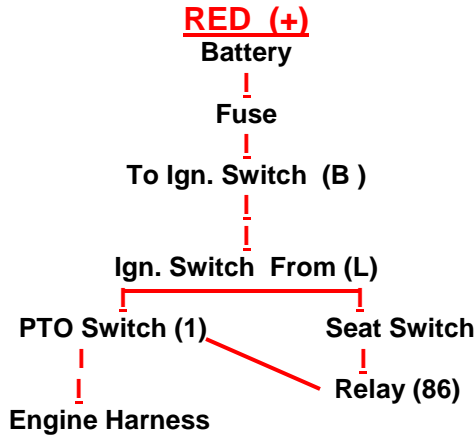

ORANGE (Starter)

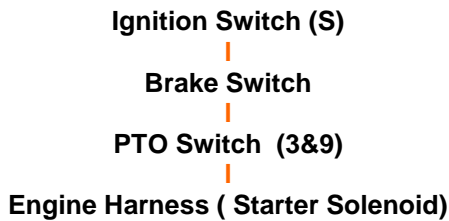

YELLOW WHITE



YELLOW (Magneto)

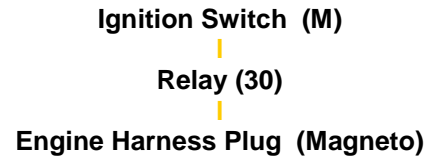

Harness To Engine

Kohler

Mating Plug Connection From Harness to Engine
Harness - Engine
 Orange / Black to Red & Blue (2 wires)
 Starter Solenoid
 Red to Red
 Yellow to White & White (2 wires)
 Magneto
 Green to Yellow (2 wires)

Kawasaki

Extension Plugged Into Kohler Harness
Harness - Engine
 Orange / Black to Starter Solenoid
 Red to Red (2 wires)
 Yellow to White & Black (2 wires)
 Magneto
 Green to Solenoid Mounting Bracket

BLUE (PTO CLUTCH)

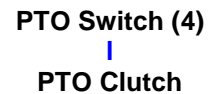

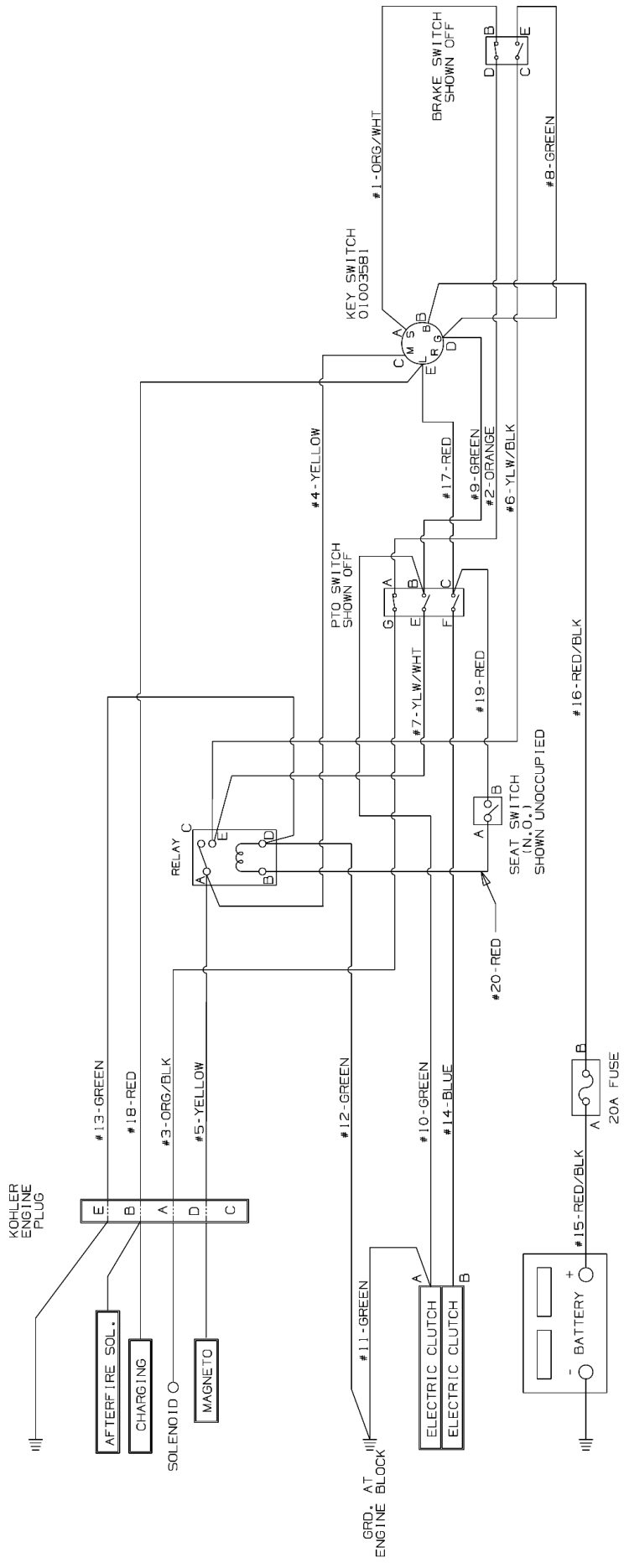

KEY SW. : 01003581

OFF	G+M+R
RUN/LIGHTS	B+R+L
START	B+S+L

DIAGNOSTICS:

PREVENTION:

The cause of most electrical issues are moisture resulting in corrosion, loose wires or contacts (mainly ground wires & cables) or damaged wires.

It is highly recommended that a part of regular service is to inspect the electrical system including all related components. This is especially true in areas of high humidity, exposure to lawn chemicals, units stored outdoors or units that are pressure washed frequently.

Begin at the ignition switch, service all switches, relays and timers along the wire harness.

Unplug each component and clean with electrical contact cleaner.

Inspect the plug connectors to be sure all wires are secure within the housing.

Coat connections and mating surfaces with Di-Electric Grease and reassemble.

As you go through the electrical system check wiring for damaged insulation and crushed or crimped wires.

Repair or replace as required.

SYMPTOM / DIAGNOSIS:

BEFORE DIAGNOSING ELECTRICAL SYSTEMS, ALWAYS, CHECK GROUND CONNECTIONS AND BATTERY CONDITION.

Engine Starter Will Not Turn Over. (Brake On, PTO Switch Off, Operator in Seat)

- 1) Pull Switch to Engage PTO.
Click Yes = Current in System. - Go to #3
Click NO = No Current in System. - Go to #2
- 2) Check Fuse.
Bad = Replace (May Blow Again if Short In System)
Good = OK Current From Battery to Ignition Switch. Go to #3
- 3) Check Current, Orange Wire @ Starter Solenoid. Key in Start Position.
Current Reading 10 – 12 volts = Possible faulty solenoid or starter.
Current Reading Less Than 10 – 12 volts = Low Battery or Current Drop thru Components.
No Current Reading. = Dead Battery or Faulty Orange Wire Circuit.
Trace Orange Wire Circuit from Ignition Switch thru System.

Engine Starter Will Turn Over, Engine Will Not Start.. (Brake On, PTO Switch Off, Operator in Seat)

- 1) Fuel in System and Tank Fuel Valves Open.
- 2) Turn Key from Off to On Position. - Listen for Click at Engine Carb.
No Click = Faulty Afterfire Solenoid or No Current to Solenoid.
Yes Click = Afterfire Solenoid Functional
- 3) Check Engine Spark.
Yes Spark to Spark Plugs = Non Starting not Due to Electrical Problem.
No Spark to Spark Plugs = Possible Yellow Wire Grounding Magneto.
- 4) Disconnect Yellow Wire From Engine Circuit at Engine Harness Plug.
No Spark to Spark Plugs = No Spark not Due to (Yellow Wire) Grounding Magneto.
Yes Spark to Spark Plugs = Harness (Yellow Wire) Grounding Magneto.
Trace Yellow Wire Circuits from Ignition Switch to Relay and Yellow / White Wire Brake, PTO Switches to Relay.

Engine Shuts Down When Brake is Released or PTO Switch is Engaged.

(Brake On, PTO Switch Off, Operator in Seat)

The primary cause of this symptom is current not going to the relay via the seat switch or a faulty relay.

- 1) Unplug seat switch and (For Diagnostic Purpose Only) Install a Jumper Wire Between the Contacts in the Harness Seat Plug.
System Operates Normally = Faulty Seat Switch.
Symptom Still Present = Relay not Operating Properly. Check Circuits and Operation.

NOTES