

**MODEL 1610
SERIAL NUMBER (108,000 - 114,000)**

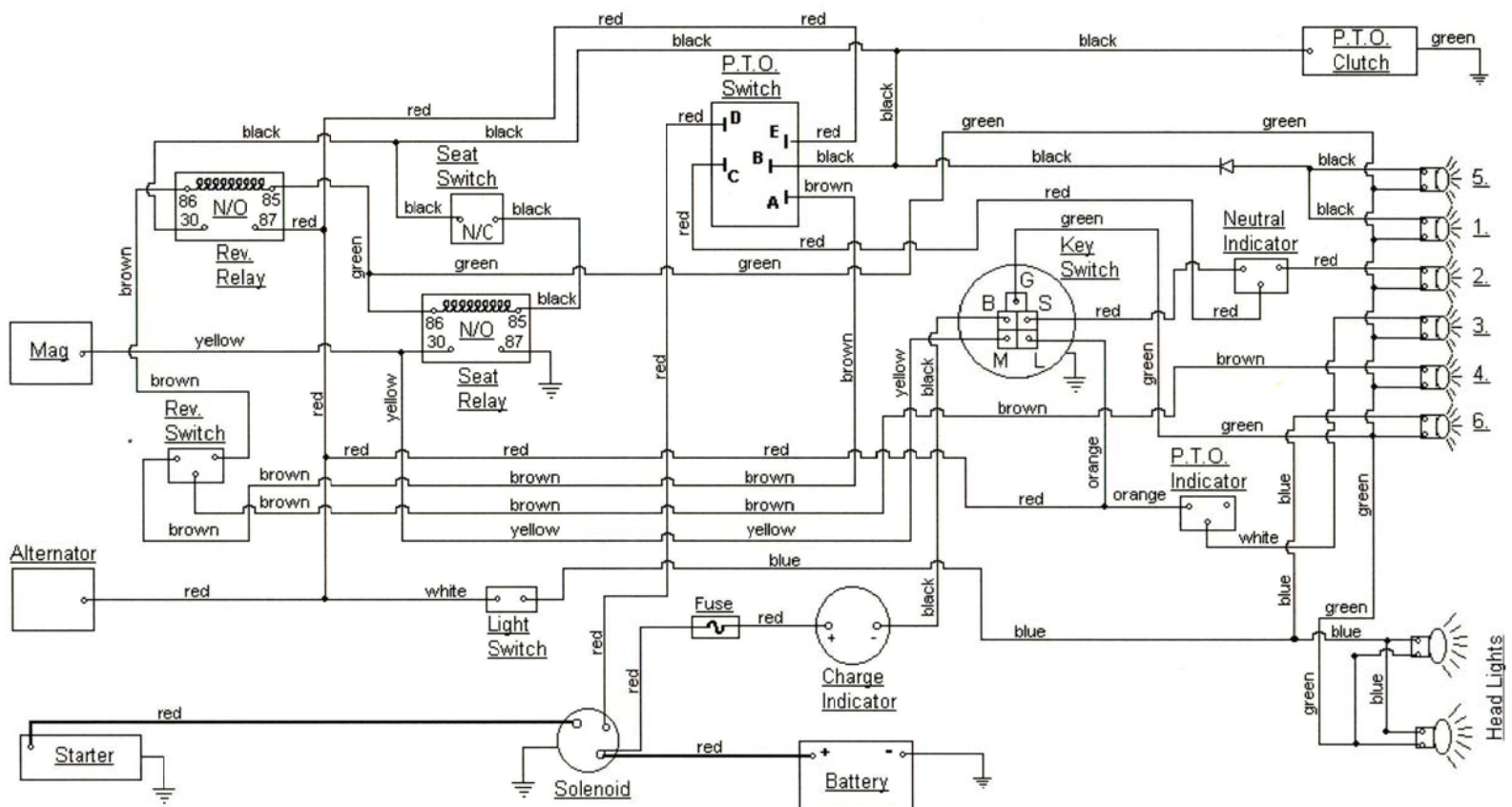

PTO SWITCH	
OFF	D+C
ON	B+A
START	B+A+E

KEY SWITCH	
OFF	M+G
RUN	B+L
START	B+S

DASH LIGHTS	
1: P.T.O. ON	4: DO NOT ENGAGE P.T.O.
2: PLACE IN NEUTRAL	5: FULL THROTTLE REQUIRED
3: IN REVERSE GEAR	6: FULL THROTTLE REQUIRED